



Collezioni 2023

Materia per i tuoi progetti

◆ CAESAR ◆
C E R A M I C H E

Indice

Index

| | |
|----------------------------------|-----|
| Azienda | 4 |
| Corporate | |
| Collezioni | 28 |
| Collections | |
| Metal Look | 30 |
| Concrete Look | 54 |
| Marble Look | 112 |
| Wood Look | 150 |
| Stone Look | 210 |
| Caesar Contract Solutions | 286 |
| Deco Solutions | 322 |
| Aextra20 | 336 |
| Aextra30 | 360 |
| Project Evolution | 366 |
| Olos | 384 |
| Caesartech Solutions | 396 |
| Dettagli tecnici | 440 |
| Technical details | |



Materia per i tuoi progetti

Material for your projects

• CAESAR •
CERAMICHE

Indice

Index

| | | | | | | | | | | | | | | | | | | | | | | | | | | | | | | | | | | | | | | | | | | | | | | | | | | | | | | | | | | | | | | | | | | | | | | | | | | | | | | | | | | | | | | | | | | | | | | | | | | | | | | | | | | | | | | | | | | | | | | | | | | | | | | | | | | | | | | | | | | | | | | | | | | | | | | | | | | | | | | | | | | | | | | | | | | | | |
|--------------------------------------------------------------------------------------------------------------------------------------------------------------------------------------------------------------------------------------------------------------------------------------------------------------------------------------------------------------------------------------------------------------------------------------------------------------------------------------------------------------------------------------------------------------------------------------------------------------------------------------------------------------------------------------------------------------------------------------------------------------------------------------------------------------------------------------------------------------------------------------------------------------------------------------------------------------------------------------------------------------------------------------------------------------------------------------------------------------------------------------------------------------------------------------------------------------------------------------------------------------------------------------------------------------------------------------------------------------------------------------------------------------------------------------------------------------------------------------------------------------------------------------------------------------------------------|-----------------------|-------------------------------------------------------------------------------------------------------------------------------------------------------------------------------------------------------------------------------------------------------------------------------------------------------------------------------------------------------------------------------------------------------------|-----------------------------------------------------------------------------------------------------------------------------------------------------------------------------------------------------------------------------------------------------------------------------------------------------------------------------------------------------------------------------------------------------------------------------------------------------------------------------------------------------------------------------|-----------------|------------|----------------------------------|-----------------------------|-----------------------------------|------------------------|-----------------------------------|----------------------|--------------------------------|------------------------|-----------------------------------|------------------------|------------------------------------|---------------------------|--------------------------------------|-------------------------------|----------------------------------------------------------------------------------------------------------------------------|-----------------|----------------------------------------------------------------------------------------------------------------------------------------------------------------------------------------------------------------------------------------------------------------------------------------------------------------------------------------------------------------------------------------------------------------------------------------------------------------------------------------------------------------------------------------------------------------------------------------------------------------------------------------------------------------------------------------------------------------------------|-------------------------|------------|-----------------------------------------------------------------------------------------------------------------------------------------------------------------------------------------------------------------------------------------------------------------------------------------------------------------------|--------------------------|----------------------------|-----------------------------------|---------------------------|------------------------------------|------------------|--------------------------------|------------------------|-------------|--------------------------------------------|------------------------------------------------------------------------------|----------------------------------------|------------|-------------------------------|----|--------------------------------|-----|--------------------|----|------------------------------|-----|----------------------------|--|-----------------------|--|--------------------------------|----|---------------------------|--|----------------------------|----|----------------------------|--|------------------------------------------------------------------------------------------------------------------------------------------------------------------------------------------------------------------------------------------------------------------------------------------------------------------------------------------------------------------------------------------------------------------------------------------------------------------------------------------------------------------------------------------------------------------------------------------------------------------------------------------------------------------------------------------------------------------------------------------------------------------------------------------------------------------------------------------------------------------------------------------------------------------------------------------------------------------------------------------------------------------------------------------------------------------------------------------------------------------------------------------------------------------------------------|---------------------|-----------|-------------|--|--|--|---------------------|-----------|---------|----|--------------|----|--|--|-------------------------|-----------|--------|----|-------|----|-------|----|------|----|----------|----|-------|-----|--|--|-----------------------|------------|-------|-----|------------|-----|--------------|-----|--|--|---------------------|------------|--------|-----|--------|-----|--------|-----|------|-----|------|-----|------|-----|------|-----|--------------------------------------------------------------------------------------------------------------------------------------------------------------------------------------------------------------------------------------------------------------|----------------------------------|------------|--------|-----|------|-----|---------------|-----|------|-----|---------------------------------------------------------------------------------------------------------------------------------------------------------------------------------------------------------------------------------------------------------------------------------------------------------------------------|-----------------------------|------------|--------|-----|---------|-----|-------|-----|-------|-----|--------|-----|--------|-----|-----------------------------------------------------------------------------------------------------------------------------------------------------------------------------------------------------------------------------------------------------------------------------------------------------------------------------------------------------------------------------------------------------------------------------------------------------------------------------------------------------------------------------------------------------------------------------------------------------------------------------------------------------------------------------------------------------------------------------------------------------------------------------------------------------------|-------------------|-----|---------------|-----|-----------------------|--|------|--|---------------|-----|-----------------------|--|---------------------------|-----|---------------------|--|--------------------------------------|--|--------------------------|-----|-----------------------------|--|-------------------------|-----|----------------------|--|--------------------------|-----|------------------------|--|
| | | <table border="0"> <tr><td>Stone Look</td><td>210</td></tr> <tr><td>Clash</td><td>214</td></tr> <tr><td>Core</td><td>222</td></tr> <tr><td>Eikon</td><td>232</td></tr> <tr><td>Inner</td><td>238</td></tr> <tr><td>Key_Mood</td><td>246</td></tr> <tr><td>Portraits</td><td>256</td></tr> <tr><td>Quartz Essence</td><td>266</td></tr> <tr><td>Shapes of Italy</td><td>276</td></tr> </table> | Stone Look | 210 | Clash | 214 | Core | 222 | Eikon | 232 | Inner | 238 | Key_Mood | 246 | Portraits | 256 | Quartz Essence | 266 | Shapes of Italy | 276 | | <table border="0"> <tr><td>Dettagli tecnici</td><td>440</td></tr> <tr><td>Technical details</td><td></td></tr> <tr><td> </td><td> </td></tr> <tr><td>Finiture</td><td>442</td></tr> <tr><td>Finishes</td><td></td></tr> <tr><td>Informazioni estetiche</td><td>446</td></tr> <tr><td>Aesthetic information</td><td></td></tr> <tr><td>Decori</td><td>447</td></tr> <tr><td>Decors</td><td></td></tr> <tr><td>Scalini sagomati</td><td>461</td></tr> <tr><td>Step treads</td><td></td></tr> <tr><td>Manuale di posa, uso,</td><td>462</td></tr> <tr><td>pulizia e manutenzione</td><td></td></tr> <tr><td>Laying, use, cleaning</td><td></td></tr> <tr><td>and maintenance manual</td><td></td></tr> </table> | Dettagli tecnici | 440 | Technical details | | | | Finiture | 442 | Finishes | | Informazioni estetiche | 446 | Aesthetic information | | Decori | 447 | Decors | | Scalini sagomati | 461 | Step treads | | Manuale di posa, uso, | 462 | pulizia e manutenzione | | Laying, use, cleaning | | and maintenance manual | | | | | | | | | | | | | | | | | | | | | | | | | | | | | | | | | | | | | | | | | | | | | | | | | | | | | | | | | | | | | | | | | | | | | | | | | | | | | | | | | | | | | | | | | | | | | | | | | | | | | | | | | | | | | | | | | | | | | | | | | |
| Stone Look | 210 | | | | | | | | | | | | | | | | | | | | | | | | | | | | | | | | | | | | | | | | | | | | | | | | | | | | | | | | | | | | | | | | | | | | | | | | | | | | | | | | | | | | | | | | | | | | | | | | | | | | | | | | | | | | | | | | | | | | | | | | | | | | | | | | | | | | | | | | | | | | | | | | | | | | | | | | | | | | | | | | | | | | | | | | | | | |
| Clash | 214 | | | | | | | | | | | | | | | | | | | | | | | | | | | | | | | | | | | | | | | | | | | | | | | | | | | | | | | | | | | | | | | | | | | | | | | | | | | | | | | | | | | | | | | | | | | | | | | | | | | | | | | | | | | | | | | | | | | | | | | | | | | | | | | | | | | | | | | | | | | | | | | | | | | | | | | | | | | | | | | | | | | | | | | | | | | |
| Core | 222 | | | | | | | | | | | | | | | | | | | | | | | | | | | | | | | | | | | | | | | | | | | | | | | | | | | | | | | | | | | | | | | | | | | | | | | | | | | | | | | | | | | | | | | | | | | | | | | | | | | | | | | | | | | | | | | | | | | | | | | | | | | | | | | | | | | | | | | | | | | | | | | | | | | | | | | | | | | | | | | | | | | | | | | | | | | |
| Eikon | 232 | | | | | | | | | | | | | | | | | | | | | | | | | | | | | | | | | | | | | | | | | | | | | | | | | | | | | | | | | | | | | | | | | | | | | | | | | | | | | | | | | | | | | | | | | | | | | | | | | | | | | | | | | | | | | | | | | | | | | | | | | | | | | | | | | | | | | | | | | | | | | | | | | | | | | | | | | | | | | | | | | | | | | | | | | | | |
| Inner | 238 | | | | | | | | | | | | | | | | | | | | | | | | | | | | | | | | | | | | | | | | | | | | | | | | | | | | | | | | | | | | | | | | | | | | | | | | | | | | | | | | | | | | | | | | | | | | | | | | | | | | | | | | | | | | | | | | | | | | | | | | | | | | | | | | | | | | | | | | | | | | | | | | | | | | | | | | | | | | | | | | | | | | | | | | | | | |
| Key_Mood | 246 | | | | | | | | | | | | | | | | | | | | | | | | | | | | | | | | | | | | | | | | | | | | | | | | | | | | | | | | | | | | | | | | | | | | | | | | | | | | | | | | | | | | | | | | | | | | | | | | | | | | | | | | | | | | | | | | | | | | | | | | | | | | | | | | | | | | | | | | | | | | | | | | | | | | | | | | | | | | | | | | | | | | | | | | | | | |
| Portraits | 256 | | | | | | | | | | | | | | | | | | | | | | | | | | | | | | | | | | | | | | | | | | | | | | | | | | | | | | | | | | | | | | | | | | | | | | | | | | | | | | | | | | | | | | | | | | | | | | | | | | | | | | | | | | | | | | | | | | | | | | | | | | | | | | | | | | | | | | | | | | | | | | | | | | | | | | | | | | | | | | | | | | | | | | | | | | | |
| Quartz Essence | 266 | | | | | | | | | | | | | | | | | | | | | | | | | | | | | | | | | | | | | | | | | | | | | | | | | | | | | | | | | | | | | | | | | | | | | | | | | | | | | | | | | | | | | | | | | | | | | | | | | | | | | | | | | | | | | | | | | | | | | | | | | | | | | | | | | | | | | | | | | | | | | | | | | | | | | | | | | | | | | | | | | | | | | | | | | | | |
| Shapes of Italy | 276 | | | | | | | | | | | | | | | | | | | | | | | | | | | | | | | | | | | | | | | | | | | | | | | | | | | | | | | | | | | | | | | | | | | | | | | | | | | | | | | | | | | | | | | | | | | | | | | | | | | | | | | | | | | | | | | | | | | | | | | | | | | | | | | | | | | | | | | | | | | | | | | | | | | | | | | | | | | | | | | | | | | | | | | | | | | |
| Dettagli tecnici | 440 | | | | | | | | | | | | | | | | | | | | | | | | | | | | | | | | | | | | | | | | | | | | | | | | | | | | | | | | | | | | | | | | | | | | | | | | | | | | | | | | | | | | | | | | | | | | | | | | | | | | | | | | | | | | | | | | | | | | | | | | | | | | | | | | | | | | | | | | | | | | | | | | | | | | | | | | | | | | | | | | | | | | | | | | | | | |
| Technical details | | | | | | | | | | | | | | | | | | | | | | | | | | | | | | | | | | | | | | | | | | | | | | | | | | | | | | | | | | | | | | | | | | | | | | | | | | | | | | | | | | | | | | | | | | | | | | | | | | | | | | | | | | | | | | | | | | | | | | | | | | | | | | | | | | | | | | | | | | | | | | | | | | | | | | | | | | | | | | | | | | | | | | | | | | | | |
| | | | | | | | | | | | | | | | | | | | | | | | | | | | | | | | | | | | | | | | | | | | | | | | | | | | | | | | | | | | | | | | | | | | | | | | | | | | | | | | | | | | | | | | | | | | | | | | | | | | | | | | | | | | | | | | | | | | | | | | | | | | | | | | | | | | | | | | | | | | | | | | | | | | | | | | | | | | | | | | | | | | | | | | | | | | | |
| Finiture | 442 | | | | | | | | | | | | | | | | | | | | | | | | | | | | | | | | | | | | | | | | | | | | | | | | | | | | | | | | | | | | | | | | | | | | | | | | | | | | | | | | | | | | | | | | | | | | | | | | | | | | | | | | | | | | | | | | | | | | | | | | | | | | | | | | | | | | | | | | | | | | | | | | | | | | | | | | | | | | | | | | | | | | | | | | | | | |
| Finishes | | | | | | | | | | | | | | | | | | | | | | | | | | | | | | | | | | | | | | | | | | | | | | | | | | | | | | | | | | | | | | | | | | | | | | | | | | | | | | | | | | | | | | | | | | | | | | | | | | | | | | | | | | | | | | | | | | | | | | | | | | | | | | | | | | | | | | | | | | | | | | | | | | | | | | | | | | | | | | | | | | | | | | | | | | | | |
| Informazioni estetiche | 446 | | | | | | | | | | | | | | | | | | | | | | | | | | | | | | | | | | | | | | | | | | | | | | | | | | | | | | | | | | | | | | | | | | | | | | | | | | | | | | | | | | | | | | | | | | | | | | | | | | | | | | | | | | | | | | | | | | | | | | | | | | | | | | | | | | | | | | | | | | | | | | | | | | | | | | | | | | | | | | | | | | | | | | | | | | | |
| Aesthetic information | | | | | | | | | | | | | | | | | | | | | | | | | | | | | | | | | | | | | | | | | | | | | | | | | | | | | | | | | | | | | | | | | | | | | | | | | | | | | | | | | | | | | | | | | | | | | | | | | | | | | | | | | | | | | | | | | | | | | | | | | | | | | | | | | | | | | | | | | | | | | | | | | | | | | | | | | | | | | | | | | | | | | | | | | | | | |
| Decori | 447 | | | | | | | | | | | | | | | | | | | | | | | | | | | | | | | | | | | | | | | | | | | | | | | | | | | | | | | | | | | | | | | | | | | | | | | | | | | | | | | | | | | | | | | | | | | | | | | | | | | | | | | | | | | | | | | | | | | | | | | | | | | | | | | | | | | | | | | | | | | | | | | | | | | | | | | | | | | | | | | | | | | | | | | | | | | |
| Decors | | | | | | | | | | | | | | | | | | | | | | | | | | | | | | | | | | | | | | | | | | | | | | | | | | | | | | | | | | | | | | | | | | | | | | | | | | | | | | | | | | | | | | | | | | | | | | | | | | | | | | | | | | | | | | | | | | | | | | | | | | | | | | | | | | | | | | | | | | | | | | | | | | | | | | | | | | | | | | | | | | | | | | | | | | | | |
| Scalini sagomati | 461 | | | | | | | | | | | | | | | | | | | | | | | | | | | | | | | | | | | | | | | | | | | | | | | | | | | | | | | | | | | | | | | | | | | | | | | | | | | | | | | | | | | | | | | | | | | | | | | | | | | | | | | | | | | | | | | | | | | | | | | | | | | | | | | | | | | | | | | | | | | | | | | | | | | | | | | | | | | | | | | | | | | | | | | | | | | |
| Step treads | | | | | | | | | | | | | | | | | | | | | | | | | | | | | | | | | | | | | | | | | | | | | | | | | | | | | | | | | | | | | | | | | | | | | | | | | | | | | | | | | | | | | | | | | | | | | | | | | | | | | | | | | | | | | | | | | | | | | | | | | | | | | | | | | | | | | | | | | | | | | | | | | | | | | | | | | | | | | | | | | | | | | | | | | | | | |
| Manuale di posa, uso, | 462 | | | | | | | | | | | | | | | | | | | | | | | | | | | | | | | | | | | | | | | | | | | | | | | | | | | | | | | | | | | | | | | | | | | | | | | | | | | | | | | | | | | | | | | | | | | | | | | | | | | | | | | | | | | | | | | | | | | | | | | | | | | | | | | | | | | | | | | | | | | | | | | | | | | | | | | | | | | | | | | | | | | | | | | | | | | |
| pulizia e manutenzione | | | | | | | | | | | | | | | | | | | | | | | | | | | | | | | | | | | | | | | | | | | | | | | | | | | | | | | | | | | | | | | | | | | | | | | | | | | | | | | | | | | | | | | | | | | | | | | | | | | | | | | | | | | | | | | | | | | | | | | | | | | | | | | | | | | | | | | | | | | | | | | | | | | | | | | | | | | | | | | | | | | | | | | | | | | | |
| Laying, use, cleaning | | | | | | | | | | | | | | | | | | | | | | | | | | | | | | | | | | | | | | | | | | | | | | | | | | | | | | | | | | | | | | | | | | | | | | | | | | | | | | | | | | | | | | | | | | | | | | | | | | | | | | | | | | | | | | | | | | | | | | | | | | | | | | | | | | | | | | | | | | | | | | | | | | | | | | | | | | | | | | | | | | | | | | | | | | | | |
| and maintenance manual | | | | | | | | | | | | | | | | | | | | | | | | | | | | | | | | | | | | | | | | | | | | | | | | | | | | | | | | | | | | | | | | | | | | | | | | | | | | | | | | | | | | | | | | | | | | | | | | | | | | | | | | | | | | | | | | | | | | | | | | | | | | | | | | | | | | | | | | | | | | | | | | | | | | | | | | | | | | | | | | | | | | | | | | | | | | |
| <table border="0"> <tr><td>Azienda</td><td>4</td></tr> <tr><td>Corporate</td><td></td></tr> <tr><td> </td><td> </td></tr> <tr><td>Il grès porcellanato Caesar</td><td>6</td></tr> <tr><td>Caesar porcelain tiles</td><td></td></tr> <tr><td>Qualità e tecnologia</td><td>8</td></tr> <tr><td>Quality and technology</td><td></td></tr> <tr><td>Ampiezza e versatilità</td><td>10</td></tr> <tr><td>Amplitude and versatility</td><td></td></tr> <tr><td>Prodotti, soluzioni e servizi</td><td>12</td></tr> <tr><td>per il Design</td><td></td></tr> <tr><td>Products, solutions and</td><td></td></tr> <tr><td>services for Design</td><td></td></tr> <tr><td>Una grande storia italiana</td><td>14</td></tr> <tr><td>A great all-italian story</td><td></td></tr> <tr><td>Every day counts</td><td>16</td></tr> <tr><td> </td><td> </td></tr> <tr><td>Attitudine per il riciclo e la circolarità</td><td>18</td></tr> <tr><td>Attitude for recycling and circularity</td><td></td></tr> <tr><td>Un impegno sempre certificato</td><td>20</td></tr> <tr><td>An always-certified commitment</td><td></td></tr> <tr><td>Impegno quotidiano</td><td>22</td></tr> <tr><td>per le persone e la comunità</td><td></td></tr> <tr><td>Daily commitment to people</td><td></td></tr> <tr><td>and the community</td><td></td></tr> <tr><td>I nostri spazi per le tue idee</td><td>24</td></tr> <tr><td>Our spaces for your ideas</td><td></td></tr> <tr><td>Al tuo fianco anche online</td><td>26</td></tr> <tr><td>By your side, also on-line</td><td></td></tr> </table> | Azienda | 4 | Corporate | | | | Il grès porcellanato Caesar | 6 | Caesar porcelain tiles | | Qualità e tecnologia | 8 | Quality and technology | | Ampiezza e versatilità | 10 | Amplitude and versatility | | Prodotti, soluzioni e servizi | 12 | per il Design | | Products, solutions and | | services for Design | | Una grande storia italiana | 14 | A great all-italian story | | Every day counts | 16 | | | Attitudine per il riciclo e la circolarità | 18 | Attitude for recycling and circularity | | Un impegno sempre certificato | 20 | An always-certified commitment | | Impegno quotidiano | 22 | per le persone e la comunità | | Daily commitment to people | | and the community | | I nostri spazi per le tue idee | 24 | Our spaces for your ideas | | Al tuo fianco anche online | 26 | By your side, also on-line | | <table border="0"> <tr><td>4 Collezioni</td><td>28</td></tr> <tr><td>Collections</td><td></td></tr> <tr><td> </td><td> </td></tr> <tr><td>6 Metal Look</td><td>30</td></tr> <tr><td>Alchemy</td><td>34</td></tr> <tr><td>Relate Flame</td><td>46</td></tr> <tr><td> </td><td> </td></tr> <tr><td>10 Concrete Look</td><td>54</td></tr> <tr><td>Autore</td><td>58</td></tr> <tr><td>Built</td><td>64</td></tr> <tr><td>I.Mat</td><td>72</td></tr> <tr><td>Join</td><td>80</td></tr> <tr><td>Materica</td><td>90</td></tr> <tr><td>Prima</td><td>100</td></tr> <tr><td> </td><td> </td></tr> <tr><td>16 Marble Look</td><td>112</td></tr> <tr><td>Anima</td><td>116</td></tr> <tr><td>Anima Ever</td><td>126</td></tr> <tr><td>Anima Futura</td><td>138</td></tr> <tr><td> </td><td> </td></tr> <tr><td>20 Wood Look</td><td>150</td></tr> <tr><td>Arthis</td><td>154</td></tr> <tr><td>Cocoon</td><td>160</td></tr> <tr><td>Fabula</td><td>172</td></tr> <tr><td>Hike</td><td>178</td></tr> <tr><td>Life</td><td>186</td></tr> <tr><td>Meet</td><td>194</td></tr> <tr><td>Vibe</td><td>204</td></tr> </table> | 4 Collezioni | 28 | Collections | | | | 6 Metal Look | 30 | Alchemy | 34 | Relate Flame | 46 | | | 10 Concrete Look | 54 | Autore | 58 | Built | 64 | I.Mat | 72 | Join | 80 | Materica | 90 | Prima | 100 | | | 16 Marble Look | 112 | Anima | 116 | Anima Ever | 126 | Anima Futura | 138 | | | 20 Wood Look | 150 | Arthis | 154 | Cocoon | 160 | Fabula | 172 | Hike | 178 | Life | 186 | Meet | 194 | Vibe | 204 | <table border="0"> <tr><td>Caesar Contract Solutions</td><td>286</td></tr> <tr><td>Pillar</td><td>290</td></tr> <tr><td>Slab</td><td>298</td></tr> <tr><td>Step in & out</td><td>306</td></tr> <tr><td>Wide</td><td>314</td></tr> </table> | Caesar Contract Solutions | 286 | Pillar | 290 | Slab | 298 | Step in & out | 306 | Wide | 314 | <table border="0"> <tr><td>Caesartech Solutions</td><td>396</td></tr> <tr><td>Aeleva</td><td>400</td></tr> <tr><td>Aexacta</td><td>406</td></tr> <tr><td>Aquae</td><td>414</td></tr> <tr><td>Cover</td><td>424</td></tr> <tr><td>Misura</td><td>428</td></tr> <tr><td>Safety</td><td>434</td></tr> </table> | Caesartech Solutions | 396 | Aeleva | 400 | Aexacta | 406 | Aquae | 414 | Cover | 424 | Misura | 428 | Safety | 434 | <table border="0"> <tr><td>Project Evolution</td><td>480</td></tr> <tr><td>Note tecniche</td><td>480</td></tr> <tr><td>Technical information</td><td></td></tr> <tr><td>OLOS</td><td></td></tr> <tr><td>Note tecniche</td><td>492</td></tr> <tr><td>Technical information</td><td></td></tr> <tr><td>Certificazioni dei nostri</td><td>494</td></tr> <tr><td>sistemi di gestione</td><td></td></tr> <tr><td>Our management system certifications</td><td></td></tr> <tr><td>Certificazioni e analisi</td><td>498</td></tr> <tr><td>Certifications and analyses</td><td></td></tr> <tr><td>Caesar per il Leed V4.1</td><td>500</td></tr> <tr><td>Caesar for Leed v4.1</td><td></td></tr> <tr><td>Informazioni commerciali</td><td>501</td></tr> <tr><td>Commercial information</td><td></td></tr> </table> | Project Evolution | 480 | Note tecniche | 480 | Technical information | | OLOS | | Note tecniche | 492 | Technical information | | Certificazioni dei nostri | 494 | sistemi di gestione | | Our management system certifications | | Certificazioni e analisi | 498 | Certifications and analyses | | Caesar per il Leed V4.1 | 500 | Caesar for Leed v4.1 | | Informazioni commerciali | 501 | Commercial information | |
| Azienda | 4 | | | | | | | | | | | | | | | | | | | | | | | | | | | | | | | | | | | | | | | | | | | | | | | | | | | | | | | | | | | | | | | | | | | | | | | | | | | | | | | | | | | | | | | | | | | | | | | | | | | | | | | | | | | | | | | | | | | | | | | | | | | | | | | | | | | | | | | | | | | | | | | | | | | | | | | | | | | | | | | | | | | | | | | | | | | |
| Corporate | | | | | | | | | | | | | | | | | | | | | | | | | | | | | | | | | | | | | | | | | | | | | | | | | | | | | | | | | | | | | | | | | | | | | | | | | | | | | | | | | | | | | | | | | | | | | | | | | | | | | | | | | | | | | | | | | | | | | | | | | | | | | | | | | | | | | | | | | | | | | | | | | | | | | | | | | | | | | | | | | | | | | | | | | | | | |
| | | | | | | | | | | | | | | | | | | | | | | | | | | | | | | | | | | | | | | | | | | | | | | | | | | | | | | | | | | | | | | | | | | | | | | | | | | | | | | | | | | | | | | | | | | | | | | | | | | | | | | | | | | | | | | | | | | | | | | | | | | | | | | | | | | | | | | | | | | | | | | | | | | | | | | | | | | | | | | | | | | | | | | | | | | | | |
| Il grès porcellanato Caesar | 6 | | | | | | | | | | | | | | | | | | | | | | | | | | | | | | | | | | | | | | | | | | | | | | | | | | | | | | | | | | | | | | | | | | | | | | | | | | | | | | | | | | | | | | | | | | | | | | | | | | | | | | | | | | | | | | | | | | | | | | | | | | | | | | | | | | | | | | | | | | | | | | | | | | | | | | | | | | | | | | | | | | | | | | | | | | | |
| Caesar porcelain tiles | | | | | | | | | | | | | | | | | | | | | | | | | | | | | | | | | | | | | | | | | | | | | | | | | | | | | | | | | | | | | | | | | | | | | | | | | | | | | | | | | | | | | | | | | | | | | | | | | | | | | | | | | | | | | | | | | | | | | | | | | | | | | | | | | | | | | | | | | | | | | | | | | | | | | | | | | | | | | | | | | | | | | | | | | | | | |
| Qualità e tecnologia | 8 | | | | | | | | | | | | | | | | | | | | | | | | | | | | | | | | | | | | | | | | | | | | | | | | | | | | | | | | | | | | | | | | | | | | | | | | | | | | | | | | | | | | | | | | | | | | | | | | | | | | | | | | | | | | | | | | | | | | | | | | | | | | | | | | | | | | | | | | | | | | | | | | | | | | | | | | | | | | | | | | | | | | | | | | | | | |
| Quality and technology | | | | | | | | | | | | | | | | | | | | | | | | | | | | | | | | | | | | | | | | | | | | | | | | | | | | | | | | | | | | | | | | | | | | | | | | | | | | | | | | | | | | | | | | | | | | | | | | | | | | | | | | | | | | | | | | | | | | | | | | | | | | | | | | | | | | | | | | | | | | | | | | | | | | | | | | | | | | | | | | | | | | | | | | | | | | |
| Ampiezza e versatilità | 10 | | | | | | | | | | | | | | | | | | | | | | | | | | | | | | | | | | | | | | | | | | | | | | | | | | | | | | | | | | | | | | | | | | | | | | | | | | | | | | | | | | | | | | | | | | | | | | | | | | | | | | | | | | | | | | | | | | | | | | | | | | | | | | | | | | | | | | | | | | | | | | | | | | | | | | | | | | | | | | | | | | | | | | | | | | | |
| Amplitude and versatility | | | | | | | | | | | | | | | | | | | | | | | | | | | | | | | | | | | | | | | | | | | | | | | | | | | | | | | | | | | | | | | | | | | | | | | | | | | | | | | | | | | | | | | | | | | | | | | | | | | | | | | | | | | | | | | | | | | | | | | | | | | | | | | | | | | | | | | | | | | | | | | | | | | | | | | | | | | | | | | | | | | | | | | | | | | | |
| Prodotti, soluzioni e servizi | 12 | | | | | | | | | | | | | | | | | | | | | | | | | | | | | | | | | | | | | | | | | | | | | | | | | | | | | | | | | | | | | | | | | | | | | | | | | | | | | | | | | | | | | | | | | | | | | | | | | | | | | | | | | | | | | | | | | | | | | | | | | | | | | | | | | | | | | | | | | | | | | | | | | | | | | | | | | | | | | | | | | | | | | | | | | | | |
| per il Design | | | | | | | | | | | | | | | | | | | | | | | | | | | | | | | | | | | | | | | | | | | | | | | | | | | | | | | | | | | | | | | | | | | | | | | | | | | | | | | | | | | | | | | | | | | | | | | | | | | | | | | | | | | | | | | | | | | | | | | | | | | | | | | | | | | | | | | | | | | | | | | | | | | | | | | | | | | | | | | | | | | | | | | | | | | | |
| Products, solutions and | | | | | | | | | | | | | | | | | | | | | | | | | | | | | | | | | | | | | | | | | | | | | | | | | | | | | | | | | | | | | | | | | | | | | | | | | | | | | | | | | | | | | | | | | | | | | | | | | | | | | | | | | | | | | | | | | | | | | | | | | | | | | | | | | | | | | | | | | | | | | | | | | | | | | | | | | | | | | | | | | | | | | | | | | | | | |
| services for Design | | | | | | | | | | | | | | | | | | | | | | | | | | | | | | | | | | | | | | | | | | | | | | | | | | | | | | | | | | | | | | | | | | | | | | | | | | | | | | | | | | | | | | | | | | | | | | | | | | | | | | | | | | | | | | | | | | | | | | | | | | | | | | | | | | | | | | | | | | | | | | | | | | | | | | | | | | | | | | | | | | | | | | | | | | | | |
| Una grande storia italiana | 14 | | | | | | | | | | | | | | | | | | | | | | | | | | | | | | | | | | | | | | | | | | | | | | | | | | | | | | | | | | | | | | | | | | | | | | | | | | | | | | | | | | | | | | | | | | | | | | | | | | | | | | | | | | | | | | | | | | | | | | | | | | | | | | | | | | | | | | | | | | | | | | | | | | | | | | | | | | | | | | | | | | | | | | | | | | | |
| A great all-italian story | | | | | | | | | | | | | | | | | | | | | | | | | | | | | | | | | | | | | | | | | | | | | | | | | | | | | | | | | | | | | | | | | | | | | | | | | | | | | | | | | | | | | | | | | | | | | | | | | | | | | | | | | | | | | | | | | | | | | | | | | | | | | | | | | | | | | | | | | | | | | | | | | | | | | | | | | | | | | | | | | | | | | | | | | | | | |
| Every day counts | 16 | | | | | | | | | | | | | | | | | | | | | | | | | | | | | | | | | | | | | | | | | | | | | | | | | | | | | | | | | | | | | | | | | | | | | | | | | | | | | | | | | | | | | | | | | | | | | | | | | | | | | | | | | | | | | | | | | | | | | | | | | | | | | | | | | | | | | | | | | | | | | | | | | | | | | | | | | | | | | | | | | | | | | | | | | | | |
| | | | | | | | | | | | | | | | | | | | | | | | | | | | | | | | | | | | | | | | | | | | | | | | | | | | | | | | | | | | | | | | | | | | | | | | | | | | | | | | | | | | | | | | | | | | | | | | | | | | | | | | | | | | | | | | | | | | | | | | | | | | | | | | | | | | | | | | | | | | | | | | | | | | | | | | | | | | | | | | | | | | | | | | | | | | | |
| Attitudine per il riciclo e la circolarità | 18 | | | | | | | | | | | | | | | | | | | | | | | | | | | | | | | | | | | | | | | | | | | | | | | | | | | | | | | | | | | | | | | | | | | | | | | | | | | | | | | | | | | | | | | | | | | | | | | | | | | | | | | | | | | | | | | | | | | | | | | | | | | | | | | | | | | | | | | | | | | | | | | | | | | | | | | | | | | | | | | | | | | | | | | | | | | |
| Attitude for recycling and circularity | | | | | | | | | | | | | | | | | | | | | | | | | | | | | | | | | | | | | | | | | | | | | | | | | | | | | | | | | | | | | | | | | | | | | | | | | | | | | | | | | | | | | | | | | | | | | | | | | | | | | | | | | | | | | | | | | | | | | | | | | | | | | | | | | | | | | | | | | | | | | | | | | | | | | | | | | | | | | | | | | | | | | | | | | | | | |
| Un impegno sempre certificato | 20 | | | | | | | | | | | | | | | | | | | | | | | | | | | | | | | | | | | | | | | | | | | | | | | | | | | | | | | | | | | | | | | | | | | | | | | | | | | | | | | | | | | | | | | | | | | | | | | | | | | | | | | | | | | | | | | | | | | | | | | | | | | | | | | | | | | | | | | | | | | | | | | | | | | | | | | | | | | | | | | | | | | | | | | | | | | |
| An always-certified commitment | | | | | | | | | | | | | | | | | | | | | | | | | | | | | | | | | | | | | | | | | | | | | | | | | | | | | | | | | | | | | | | | | | | | | | | | | | | | | | | | | | | | | | | | | | | | | | | | | | | | | | | | | | | | | | | | | | | | | | | | | | | | | | | | | | | | | | | | | | | | | | | | | | | | | | | | | | | | | | | | | | | | | | | | | | | | |
| Impegno quotidiano | 22 | | | | | | | | | | | | | | | | | | | | | | | | | | | | | | | | | | | | | | | | | | | | | | | | | | | | | | | | | | | | | | | | | | | | | | | | | | | | | | | | | | | | | | | | | | | | | | | | | | | | | | | | | | | | | | | | | | | | | | | | | | | | | | | | | | | | | | | | | | | | | | | | | | | | | | | | | | | | | | | | | | | | | | | | | | | |
| per le persone e la comunità | | | | | | | | | | | | | | | | | | | | | | | | | | | | | | | | | | | | | | | | | | | | | | | | | | | | | | | | | | | | | | | | | | | | | | | | | | | | | | | | | | | | | | | | | | | | | | | | | | | | | | | | | | | | | | | | | | | | | | | | | | | | | | | | | | | | | | | | | | | | | | | | | | | | | | | | | | | | | | | | | | | | | | | | | | | | |
| Daily commitment to people | | | | | | | | | | | | | | | | | | | | | | | | | | | | | | | | | | | | | | | | | | | | | | | | | | | | | | | | | | | | | | | | | | | | | | | | | | | | | | | | | | | | | | | | | | | | | | | | | | | | | | | | | | | | | | | | | | | | | | | | | | | | | | | | | | | | | | | | | | | | | | | | | | | | | | | | | | | | | | | | | | | | | | | | | | | | |
| and the community | | | | | | | | | | | | | | | | | | | | | | | | | | | | | | | | | | | | | | | | | | | | | | | | | | | | | | | | | | | | | | | | | | | | | | | | | | | | | | | | | | | | | | | | | | | | | | | | | | | | | | | | | | | | | | | | | | | | | | | | | | | | | | | | | | | | | | | | | | | | | | | | | | | | | | | | | | | | | | | | | | | | | | | | | | | | |
| I nostri spazi per le tue idee | 24 | | | | | | | | | | | | | | | | | | | | | | | | | | | | | | | | | | | | | | | | | | | | | | | | | | | | | | | | | | | | | | | | | | | | | | | | | | | | | | | | | | | | | | | | | | | | | | | | | | | | | | | | | | | | | | | | | | | | | | | | | | | | | | | | | | | | | | | | | | | | | | | | | | | | | | | | | | | | | | | | | | | | | | | | | | | |
| Our spaces for your ideas | | | | | | | | | | | | | | | | | | | | | | | | | | | | | | | | | | | | | | | | | | | | | | | | | | | | | | | | | | | | | | | | | | | | | | | | | | | | | | | | | | | | | | | | | | | | | | | | | | | | | | | | | | | | | | | | | | | | | | | | | | | | | | | | | | | | | | | | | | | | | | | | | | | | | | | | | | | | | | | | | | | | | | | | | | | | |
| Al tuo fianco anche online | 26 | | | | | | | | | | | | | | | | | | | | | | | | | | | | | | | | | | | | | | | | | | | | | | | | | | | | | | | | | | | | | | | | | | | | | | | | | | | | | | | | | | | | | | | | | | | | | | | | | | | | | | | | | | | | | | | | | | | | | | | | | | | | | | | | | | | | | | | | | | | | | | | | | | | | | | | | | | | | | | | | | | | | | | | | | | | |
| By your side, also on-line | | | | | | | | | | | | | | | | | | | | | | | | | | | | | | | | | | | | | | | | | | | | | | | | | | | | | | | | | | | | | | | | | | | | | | | | | | | | | | | | | | | | | | | | | | | | | | | | | | | | | | | | | | | | | | | | | | | | | | | | | | | | | | | | | | | | | | | | | | | | | | | | | | | | | | | | | | | | | | | | | | | | | | | | | | | | |
| 4 Collezioni | 28 | | | | | | | | | | | | | | | | | | | | | | | | | | | | | | | | | | | | | | | | | | | | | | | | | | | | | | | | | | | | | | | | | | | | | | | | | | | | | | | | | | | | | | | | | | | | | | | | | | | | | | | | | | | | | | | | | | | | | | | | | | | | | | | | | | | | | | | | | | | | | | | | | | | | | | | | | | | | | | | | | | | | | | | | | | | |
| Collections | | | | | | | | | | | | | | | | | | | | | | | | | | | | | | | | | | | | | | | | | | | | | | | | | | | | | | | | | | | | | | | | | | | | | | | | | | | | | | | | | | | | | | | | | | | | | | | | | | | | | | | | | | | | | | | | | | | | | | | | | | | | | | | | | | | | | | | | | | | | | | | | | | | | | | | | | | | | | | | | | | | | | | | | | | | | |
| | | | | | | | | | | | | | | | | | | | | | | | | | | | | | | | | | | | | | | | | | | | | | | | | | | | | | | | | | | | | | | | | | | | | | | | | | | | | | | | | | | | | | | | | | | | | | | | | | | | | | | | | | | | | | | | | | | | | | | | | | | | | | | | | | | | | | | | | | | | | | | | | | | | | | | | | | | | | | | | | | | | | | | | | | | | | |
| 6 Metal Look | 30 | | | | | | | | | | | | | | | | | | | | | | | | | | | | | | | | | | | | | | | | | | | | | | | | | | | | | | | | | | | | | | | | | | | | | | | | | | | | | | | | | | | | | | | | | | | | | | | | | | | | | | | | | | | | | | | | | | | | | | | | | | | | | | | | | | | | | | | | | | | | | | | | | | | | | | | | | | | | | | | | | | | | | | | | | | | |
| Alchemy | 34 | | | | | | | | | | | | | | | | | | | | | | | | | | | | | | | | | | | | | | | | | | | | | | | | | | | | | | | | | | | | | | | | | | | | | | | | | | | | | | | | | | | | | | | | | | | | | | | | | | | | | | | | | | | | | | | | | | | | | | | | | | | | | | | | | | | | | | | | | | | | | | | | | | | | | | | | | | | | | | | | | | | | | | | | | | | |
| Relate Flame | 46 | | | | | | | | | | | | | | | | | | | | | | | | | | | | | | | | | | | | | | | | | | | | | | | | | | | | | | | | | | | | | | | | | | | | | | | | | | | | | | | | | | | | | | | | | | | | | | | | | | | | | | | | | | | | | | | | | | | | | | | | | | | | | | | | | | | | | | | | | | | | | | | | | | | | | | | | | | | | | | | | | | | | | | | | | | | |
| | | | | | | | | | | | | | | | | | | | | | | | | | | | | | | | | | | | | | | | | | | | | | | | | | | | | | | | | | | | | | | | | | | | | | | | | | | | | | | | | | | | | | | | | | | | | | | | | | | | | | | | | | | | | | | | | | | | | | | | | | | | | | | | | | | | | | | | | | | | | | | | | | | | | | | | | | | | | | | | | | | | | | | | | | | | | |
| 10 Concrete Look | 54 | | | | | | | | | | | | | | | | | | | | | | | | | | | | | | | | | | | | | | | | | | | | | | | | | | | | | | | | | | | | | | | | | | | | | | | | | | | | | | | | | | | | | | | | | | | | | | | | | | | | | | | | | | | | | | | | | | | | | | | | | | | | | | | | | | | | | | | | | | | | | | | | | | | | | | | | | | | | | | | | | | | | | | | | | | | |
| Autore | 58 | | | | | | | | | | | | | | | | | | | | | | | | | | | | | | | | | | | | | | | | | | | | | | | | | | | | | | | | | | | | | | | | | | | | | | | | | | | | | | | | | | | | | | | | | | | | | | | | | | | | | | | | | | | | | | | | | | | | | | | | | | | | | | | | | | | | | | | | | | | | | | | | | | | | | | | | | | | | | | | | | | | | | | | | | | | |
| Built | 64 | | | | | | | | | | | | | | | | | | | | | | | | | | | | | | | | | | | | | | | | | | | | | | | | | | | | | | | | | | | | | | | | | | | | | | | | | | | | | | | | | | | | | | | | | | | | | | | | | | | | | | | | | | | | | | | | | | | | | | | | | | | | | | | | | | | | | | | | | | | | | | | | | | | | | | | | | | | | | | | | | | | | | | | | | | | |
| I.Mat | 72 | | | | | | | | | | | | | | | | | | | | | | | | | | | | | | | | | | | | | | | | | | | | | | | | | | | | | | | | | | | | | | | | | | | | | | | | | | | | | | | | | | | | | | | | | | | | | | | | | | | | | | | | | | | | | | | | | | | | | | | | | | | | | | | | | | | | | | | | | | | | | | | | | | | | | | | | | | | | | | | | | | | | | | | | | | | |
| Join | 80 | | | | | | | | | | | | | | | | | | | | | | | | | | | | | | | | | | | | | | | | | | | | | | | | | | | | | | | | | | | | | | | | | | | | | | | | | | | | | | | | | | | | | | | | | | | | | | | | | | | | | | | | | | | | | | | | | | | | | | | | | | | | | | | | | | | | | | | | | | | | | | | | | | | | | | | | | | | | | | | | | | | | | | | | | | | |
| Materica | 90 | | | | | | | | | | | | | | | | | | | | | | | | | | | | | | | | | | | | | | | | | | | | | | | | | | | | | | | | | | | | | | | | | | | | | | | | | | | | | | | | | | | | | | | | | | | | | | | | | | | | | | | | | | | | | | | | | | | | | | | | | | | | | | | | | | | | | | | | | | | | | | | | | | | | | | | | | | | | | | | | | | | | | | | | | | | |
| Prima | 100 | | | | | | | | | | | | | | | | | | | | | | | | | | | | | | | | | | | | | | | | | | | | | | | | | | | | | | | | | | | | | | | | | | | | | | | | | | | | | | | | | | | | | | | | | | | | | | | | | | | | | | | | | | | | | | | | | | | | | | | | | | | | | | | | | | | | | | | | | | | | | | | | | | | | | | | | | | | | | | | | | | | | | | | | | | | |
| | | | | | | | | | | | | | | | | | | | | | | | | | | | | | | | | | | | | | | | | | | | | | | | | | | | | | | | | | | | | | | | | | | | | | | | | | | | | | | | | | | | | | | | | | | | | | | | | | | | | | | | | | | | | | | | | | | | | | | | | | | | | | | | | | | | | | | | | | | | | | | | | | | | | | | | | | | | | | | | | | | | | | | | | | | | | |
| 16 Marble Look | 112 | | | | | | | | | | | | | | | | | | | | | | | | | | | | | | | | | | | | | | | | | | | | | | | | | | | | | | | | | | | | | | | | | | | | | | | | | | | | | | | | | | | | | | | | | | | | | | | | | | | | | | | | | | | | | | | | | | | | | | | | | | | | | | | | | | | | | | | | | | | | | | | | | | | | | | | | | | | | | | | | | | | | | | | | | | | |
| Anima | 116 | | | | | | | | | | | | | | | | | | | | | | | | | | | | | | | | | | | | | | | | | | | | | | | | | | | | | | | | | | | | | | | | | | | | | | | | | | | | | | | | | | | | | | | | | | | | | | | | | | | | | | | | | | | | | | | | | | | | | | | | | | | | | | | | | | | | | | | | | | | | | | | | | | | | | | | | | | | | | | | | | | | | | | | | | | | |
| Anima Ever | 126 | | | | | | | | | | | | | | | | | | | | | | | | | | | | | | | | | | | | | | | | | | | | | | | | | | | | | | | | | | | | | | | | | | | | | | | | | | | | | | | | | | | | | | | | | | | | | | | | | | | | | | | | | | | | | | | | | | | | | | | | | | | | | | | | | | | | | | | | | | | | | | | | | | | | | | | | | | | | | | | | | | | | | | | | | | | |
| Anima Futura | 138 | | | | | | | | | | | | | | | | | | | | | | | | | | | | | | | | | | | | | | | | | | | | | | | | | | | | | | | | | | | | | | | | | | | | | | | | | | | | | | | | | | | | | | | | | | | | | | | | | | | | | | | | | | | | | | | | | | | | | | | | | | | | | | | | | | | | | | | | | | | | | | | | | | | | | | | | | | | | | | | | | | | | | | | | | | | |
| | | | | | | | | | | | | | | | | | | | | | | | | | | | | | | | | | | | | | | | | | | | | | | | | | | | | | | | | | | | | | | | | | | | | | | | | | | | | | | | | | | | | | | | | | | | | | | | | | | | | | | | | | | | | | | | | | | | | | | | | | | | | | | | | | | | | | | | | | | | | | | | | | | | | | | | | | | | | | | | | | | | | | | | | | | | | |
| 20 Wood Look | 150 | | | | | | | | | | | | | | | | | | | | | | | | | | | | | | | | | | | | | | | | | | | | | | | | | | | | | | | | | | | | | | | | | | | | | | | | | | | | | | | | | | | | | | | | | | | | | | | | | | | | | | | | | | | | | | | | | | | | | | | | | | | | | | | | | | | | | | | | | | | | | | | | | | | | | | | | | | | | | | | | | | | | | | | | | | | |
| Arthis | 154 | | | | | | | | | | | | | | | | | | | | | | | | | | | | | | | | | | | | | | | | | | | | | | | | | | | | | | | | | | | | | | | | | | | | | | | | | | | | | | | | | | | | | | | | | | | | | | | | | | | | | | | | | | | | | | | | | | | | | | | | | | | | | | | | | | | | | | | | | | | | | | | | | | | | | | | | | | | | | | | | | | | | | | | | | | | |
| Cocoon | 160 | | | | | | | | | | | | | | | | | | | | | | | | | | | | | | | | | | | | | | | | | | | | | | | | | | | | | | | | | | | | | | | | | | | | | | | | | | | | | | | | | | | | | | | | | | | | | | | | | | | | | | | | | | | | | | | | | | | | | | | | | | | | | | | | | | | | | | | | | | | | | | | | | | | | | | | | | | | | | | | | | | | | | | | | | | | |
| Fabula | 172 | | | | | | | | | | | | | | | | | | | | | | | | | | | | | | | | | | | | | | | | | | | | | | | | | | | | | | | | | | | | | | | | | | | | | | | | | | | | | | | | | | | | | | | | | | | | | | | | | | | | | | | | | | | | | | | | | | | | | | | | | | | | | | | | | | | | | | | | | | | | | | | | | | | | | | | | | | | | | | | | | | | | | | | | | | | |
| Hike | 178 | | | | | | | | | | | | | | | | | | | | | | | | | | | | | | | | | | | | | | | | | | | | | | | | | | | | | | | | | | | | | | | | | | | | | | | | | | | | | | | | | | | | | | | | | | | | | | | | | | | | | | | | | | | | | | | | | | | | | | | | | | | | | | | | | | | | | | | | | | | | | | | | | | | | | | | | | | | | | | | | | | | | | | | | | | | |
| Life | 186 | | | | | | | | | | | | | | | | | | | | | | | | | | | | | | | | | | | | | | | | | | | | | | | | | | | | | | | | | | | | | | | | | | | | | | | | | | | | | | | | | | | | | | | | | | | | | | | | | | | | | | | | | | | | | | | | | | | | | | | | | | | | | | | | | | | | | | | | | | | | | | | | | | | | | | | | | | | | | | | | | | | | | | | | | | | |
| Meet | 194 | | | | | | | | | | | | | | | | | | | | | | | | | | | | | | | | | | | | | | | | | | | | | | | | | | | | | | | | | | | | | | | | | | | | | | | | | | | | | | | | | | | | | | | | | | | | | | | | | | | | | | | | | | | | | | | | | | | | | | | | | | | | | | | | | | | | | | | | | | | | | | | | | | | | | | | | | | | | | | | | | | | | | | | | | | | |
| Vibe | 204 | | | | | | | | | | | | | | | | | | | | | | | | | | | | | | | | | | | | | | | | | | | | | | | | | | | | | | | | | | | | | | | | | | | | | | | | | | | | | | | | | | | | | | | | | | | | | | | | | | | | | | | | | | | | | | | | | | | | | | | | | | | | | | | | | | | | | | | | | | | | | | | | | | | | | | | | | | | | | | | | | | | | | | | | | | | |
| Caesar Contract Solutions | 286 | | | | | | | | | | | | | | | | | | | | | | | | | | | | | | | | | | | | | | | | | | | | | | | | | | | | | | | | | | | | | | | | | | | | | | | | | | | | | | | | | | | | | | | | | | | | | | | | | | | | | | | | | | | | | | | | | | | | | | | | | | | | | | | | | | | | | | | | | | | | | | | | | | | | | | | | | | | | | | | | | | | | | | | | | | | |
| Pillar | 290 | | | | | | | | | | | | | | | | | | | | | | | | | | | | | | | | | | | | | | | | | | | | | | | | | | | | | | | | | | | | | | | | | | | | | | | | | | | | | | | | | | | | | | | | | | | | | | | | | | | | | | | | | | | | | | | | | | | | | | | | | | | | | | | | | | | | | | | | | | | | | | | | | | | | | | | | | | | | | | | | | | | | | | | | | | | |
| Slab | 298 | | | | | | | | | | | | | | | | | | | | | | | | | | | | | | | | | | | | | | | | | | | | | | | | | | | | | | | | | | | | | | | | | | | | | | | | | | | | | | | | | | | | | | | | | | | | | | | | | | | | | | | | | | | | | | | | | | | | | | | | | | | | | | | | | | | | | | | | | | | | | | | | | | | | | | | | | | | | | | | | | | | | | | | | | | | |
| Step in & out | 306 | | | | | | | | | | | | | | | | | | | | | | | | | | | | | | | | | | | | | | | | | | | | | | | | | | | | | | | | | | | | | | | | | | | | | | | | | | | | | | | | | | | | | | | | | | | | | | | | | | | | | | | | | | | | | | | | | | | | | | | | | | | | | | | | | | | | | | | | | | | | | | | | | | | | | | | | | | | | | | | | | | | | | | | | | | | |
| Wide | 314 | | | | | | | | | | | | | | | | | | | | | | | | | | | | | | | | | | | | | | | | | | | | | | | | | | | | | | | | | | | | | | | | | | | | | | | | | | | | | | | | | | | | | | | | | | | | | | | | | | | | | | | | | | | | | | | | | | | | | | | | | | | | | | | | | | | | | | | | | | | | | | | | | | | | | | | | | | | | | | | | | | | | | | | | | | | |
| Caesartech Solutions | 396 | | | | | | | | | | | | | | | | | | | | | | | | | | | | | | | | | | | | | | | | | | | | | | | | | | | | | | | | | | | | | | | | | | | | | | | | | | | | | | | | | | | | | | | | | | | | | | | | | | | | | | | | | | | | | | | | | | | | | | | | | | | | | | | | | | | | | | | | | | | | | | | | | | | | | | | | | | | | | | | | | | | | | | | | | | | |
| Aeleva | 400 | | | | | | | | | | | | | | | | | | | | | | | | | | | | | | | | | | | | | | | | | | | | | | | | | | | | | | | | | | | | | | | | | | | | | | | | | | | | | | | | | | | | | | | | | | | | | | | | | | | | | | | | | | | | | | | | | | | | | | | | | | | | | | | | | | | | | | | | | | | | | | | | | | | | | | | | | | | | | | | | | | | | | | | | | | | |
| Aexacta | 406 | | | | | | | | | | | | | | | | | | | | | | | | | | | | | | | | | | | | | | | | | | | | | | | | | | | | | | | | | | | | | | | | | | | | | | | | | | | | | | | | | | | | | | | | | | | | | | | | | | | | | | | | | | | | | | | | | | | | | | | | | | | | | | | | | | | | | | | | | | | | | | | | | | | | | | | | | | | | | | | | | | | | | | | | | | | |
| Aquae | 414 | | | | | | | | | | | | | | | | | | | | | | | | | | | | | | | | | | | | | | | | | | | | | | | | | | | | | | | | | | | | | | | | | | | | | | | | | | | | | | | | | | | | | | | | | | | | | | | | | | | | | | | | | | | | | | | | | | | | | | | | | | | | | | | | | | | | | | | | | | | | | | | | | | | | | | | | | | | | | | | | | | | | | | | | | | | |
| Cover | 424 | | | | | | | | | | | | | | | | | | | | | | | | | | | | | | | | | | | | | | | | | | | | | | | | | | | | | | | | | | | | | | | | | | | | | | | | | | | | | | | | | | | | | | | | | | | | | | | | | | | | | | | | | | | | | | | | | | | | | | | | | | | | | | | | | | | | | | | | | | | | | | | | | | | | | | | | | | | | | | | | | | | | | | | | | | | |
| Misura | 428 | | | | | | | | | | | | | | | | | | | | | | | | | | | | | | | | | | | | | | | | | | | | | | | | | | | | | | | | | | | | | | | | | | | | | | | | | | | | | | | | | | | | | | | | | | | | | | | | | | | | | | | | | | | | | | | | | | | | | | | | | | | | | | | | | | | | | | | | | | | | | | | | | | | | | | | | | | | | | | | | | | | | | | | | | | | |
| Safety | 434 | | | | | | | | | | | | | | | | | | | | | | | | | | | | | | | | | | | | | | | | | | | | | | | | | | | | | | | | | | | | | | | | | | | | | | | | | | | | | | | | | | | | | | | | | | | | | | | | | | | | | | | | | | | | | | | | | | | | | | | | | | | | | | | | | | | | | | | | | | | | | | | | | | | | | | | | | | | | | | | | | | | | | | | | | | | |
| Project Evolution | 480 | | | | | | | | | | | | | | | | | | | | | | | | | | | | | | | | | | | | | | | | | | | | | | | | | | | | | | | | | | | | | | | | | | | | | | | | | | | | | | | | | | | | | | | | | | | | | | | | | | | | | | | | | | | | | | | | | | | | | | | | | | | | | | | | | | | | | | | | | | | | | | | | | | | | | | | | | | | | | | | | | | | | | | | | | | | |
| Note tecniche | 480 | | | | | | | | | | | | | | | | | | | | | | | | | | | | | | | | | | | | | | | | | | | | | | | | | | | | | | | | | | | | | | | | | | | | | | | | | | | | | | | | | | | | | | | | | | | | | | | | | | | | | | | | | | | | | | | | | | | | | | | | | | | | | | | | | | | | | | | | | | | | | | | | | | | | | | | | | | | | | | | | | | | | | | | | | | | |
| Technical information | | | | | | | | | | | | | | | | | | | | | | | | | | | | | | | | | | | | | | | | | | | | | | | | | | | | | | | | | | | | | | | | | | | | | | | | | | | | | | | | | | | | | | | | | | | | | | | | | | | | | | | | | | | | | | | | | | | | | | | | | | | | | | | | | | | | | | | | | | | | | | | | | | | | | | | | | | | | | | | | | | | | | | | | | | | | |
| OLOS | | | | | | | | | | | | | | | | | | | | | | | | | | | | | | | | | | | | | | | | | | | | | | | | | | | | | | | | | | | | | | | | | | | | | | | | | | | | | | | | | | | | | | | | | | | | | | | | | | | | | | | | | | | | | | | | | | | | | | | | | | | | | | | | | | | | | | | | | | | | | | | | | | | | | | | | | | | | | | | | | | | | | | | | | | | | |
| Note tecniche | 492 | | | | | | | | | | | | | | | | | | | | | | | | | | | | | | | | | | | | | | | | | | | | | | | | | | | | | | | | | | | | | | | | | | | | | | | | | | | | | | | | | | | | | | | | | | | | | | | | | | | | | | | | | | | | | | | | | | | | | | | | | | | | | | | | | | | | | | | | | | | | | | | | | | | | | | | | | | | | | | | | | | | | | | | | | | | |
| Technical information | | | | | | | | | | | | | | | | | | | | | | | | | | | | | | | | | | | | | | | | | | | | | | | | | | | | | | | | | | | | | | | | | | | | | | | | | | | | | | | | | | | | | | | | | | | | | | | | | | | | | | | | | | | | | | | | | | | | | | | | | | | | | | | | | | | | | | | | | | | | | | | | | | | | | | | | | | | | | | | | | | | | | | | | | | | | |
| Certificazioni dei nostri | 494 | | | | | | | | | | | | | | | | | | | | | | | | | | | | | | | | | | | | | | | | | | | | | | | | | | | | | | | | | | | | | | | | | | | | | | | | | | | | | | | | | | | | | | | | | | | | | | | | | | | | | | | | | | | | | | | | | | | | | | | | | | | | | | | | | | | | | | | | | | | | | | | | | | | | | | | | | | | | | | | | | | | | | | | | | | | |
| sistemi di gestione | | | | | | | | | | | | | | | | | | | | | | | | | | | | | | | | | | | | | | | | | | | | | | | | | | | | | | | | | | | | | | | | | | | | | | | | | | | | | | | | | | | | | | | | | | | | | | | | | | | | | | | | | | | | | | | | | | | | | | | | | | | | | | | | | | | | | | | | | | | | | | | | | | | | | | | | | | | | | | | | | | | | | | | | | | | | |
| Our management system certifications | | | | | | | | | | | | | | | | | | | | | | | | | | | | | | | | | | | | | | | | | | | | | | | | | | | | | | | | | | | | | | | | | | | | | | | | | | | | | | | | | | | | | | | | | | | | | | | | | | | | | | | | | | | | | | | | | | | | | | | | | | | | | | | | | | | | | | | | | | | | | | | | | | | | | | | | | | | | | | | | | | | | | | | | | | | | |
| Certificazioni e analisi | 498 | | | | | | | | | | | | | | | | | | | | | | | | | | | | | | | | | | | | | | | | | | | | | | | | | | | | | | | | | | | | | | | | | | | | | | | | | | | | | | | | | | | | | | | | | | | | | | | | | | | | | | | | | | | | | | | | | | | | | | | | | | | | | | | | | | | | | | | | | | | | | | | | | | | | | | | | | | | | | | | | | | | | | | | | | | | |
| Certifications and analyses | | | | | | | | | | | | | | | | | | | | | | | | | | | | | | | | | | | | | | | | | | | | | | | | | | | | | | | | | | | | | | | | | | | | | | | | | | | | | | | | | | | | | | | | | | | | | | | | | | | | | | | | | | | | | | | | | | | | | | | | | | | | | | | | | | | | | | | | | | | | | | | | | | | | | | | | | | | | | | | | | | | | | | | | | | | | |
| Caesar per il Leed V4.1 | 500 | | | | | | | | | | | | | | | | | | | | | | | | | | | | | | | | | | | | | | | | | | | | | | | | | | | | | | | | | | | | | | | | | | | | | | | | | | | | | | | | | | | | | | | | | | | | | | | | | | | | | | | | | | | | | | | | | | | | | | | | | | | | | | | | | | | | | | | | | | | | | | | | | | | | | | | | | | | | | | | | | | | | | | | | | | | |
| Caesar for Leed v4.1 | | | | | | | | | | | | | | | | | | | | | | | | | | | | | | | | | | | | | | | | | | | | | | | | | | | | | | | | | | | | | | | | | | | | | | | | | | | | | | | | | | | | | | | | | | | | | | | | | | | | | | | | | | | | | | | | | | | | | | | | | | | | | | | | | | | | | | | | | | | | | | | | | | | | | | | | | | | | | | | | | | | | | | | | | | | | |
| Informazioni commerciali | 501 | | | | | | | | | | | | | | | | | | | | | | | | | | | | | | | | | | | | | | | | | | | | | | | | | | | | | | | | | | | | | | | | | | | | | | | | | | | | | | | | | | | | | | | | | | | | | | | | | | | | | | | | | | | | | | | | | | | | | | | | | | | | | | | | | | | | | | | | | | | | | | | | | | | | | | | | | | | | | | | | | | | | | | | | | | | |
| Commercial information | | | | | | | | | | | | | | | | | | | | | | | | | | | | | | | | | | | | | | | | | | | | | | | | | | | | | | | | | | | | | | | | | | | | | | | | | | | | | | | | | | | | | | | | | | | | | | | | | | | | | | | | | | | | | | | | | | | | | | | | | | | | | | | | | | | | | | | | | | | | | | | | | | | | | | | | | | | | | | | | | | | | | | | | | | | | |
| <table border="0"> <tr><td>Deco Solutions</td><td>322</td></tr> </table> | Deco Solutions | 322 | <table border="0"> <tr><td>Aextra20</td><td>336</td></tr> <tr><td>Alchemy - Arthis - Built - Clash</td><td></td></tr> <tr><td>Cocoon - Core - E.motions - Eikon</td><td></td></tr> <tr><td>Extra C - Full - Graustein - Hike</td><td></td></tr> <tr><td>I.Mat - Join - Key_Mood - Life</td><td></td></tr> <tr><td>Materica - Meet - One - Portraits</td><td></td></tr> <tr><td>Prima - Quartz Essence - Roxstones</td><td></td></tr> <tr><td>Slab - Shapes of Italy - Tale - Vibe</td><td></td></tr> </table> | Aextra20 | 336 | Alchemy - Arthis - Built - Clash | | Cocoon - Core - E.motions - Eikon | | Extra C - Full - Graustein - Hike | | I.Mat - Join - Key_Mood - Life | | Materica - Meet - One - Portraits | | Prima - Quartz Essence - Roxstones | | Slab - Shapes of Italy - Tale - Vibe | | <table border="0"> <tr><td>Aextra30</td><td>360</td></tr> <tr><td>Extra C - Tale</td><td></td></tr> </table> | Aextra30 | 360 | Extra C - Tale | | <table border="0"> <tr><td>Project Evolution</td><td>366</td></tr> <tr><td>Anima - Anima Ever - Anima Futura</td><td></td></tr> <tr><td>Alchemy - Join - Portraits - Prima</td><td></td></tr> <tr><td>Relate Flame - Shapes of Italy</td><td></td></tr> <tr><td>Tinte Unite</td><td></td></tr> </table> | Project Evolution | 366 | Anima - Anima Ever - Anima Futura | | Alchemy - Join - Portraits - Prima | | Relate Flame - Shapes of Italy | | Tinte Unite | | <table border="0"> <tr><td>Olos</td><td>384</td></tr> </table> | Olos | 384 | | | | | | | | | | | | | | | | | | | | | | | | | | | | | | | | | | | | | | | | | | | | | | | | | | | | | | | | | | | | | | | | | | | | | | | | | | | | | | | | | | | | | | | | | | | | | | | | | | | | | | | | | | | | | | | | | | | | | | | | | | | | | | | | | | | | | | |
| Deco Solutions | 322 | | | | | | | | | | | | | | | | | | | | | | | | | | | | | | | | | | | | | | | | | | | | | | | | | | | | | | | | | | | | | | | | | | | | | | | | | | | | | | | | | | | | | | | | | | | | | | | | | | | | | | | | | | | | | | | | | | | | | | | | | | | | | | | | | | | | | | | | | | | | | | | | | | | | | | | | | | | | | | | | | | | | | | | | | | | |
| Aextra20 | 336 | | | | | | | | | | | | | | | | | | | | | | | | | | | | | | | | | | | | | | | | | | | | | | | | | | | | | | | | | | | | | | | | | | | | | | | | | | | | | | | | | | | | | | | | | | | | | | | | | | | | | | | | | | | | | | | | | | | | | | | | | | | | | | | | | | | | | | | | | | | | | | | | | | | | | | | | | | | | | | | | | | | | | | | | | | | |
| Alchemy - Arthis - Built - Clash | | | | | | | | | | | | | | | | | | | | | | | | | | | | | | | | | | | | | | | | | | | | | | | | | | | | | | | | | | | | | | | | | | | | | | | | | | | | | | | | | | | | | | | | | | | | | | | | | | | | | | | | | | | | | | | | | | | | | | | | | | | | | | | | | | | | | | | | | | | | | | | | | | | | | | | | | | | | | | | | | | | | | | | | | | | | |
| Cocoon - Core - E.motions - Eikon | | | | | | | | | | | | | | | | | | | | | | | | | | | | | | | | | | | | | | | | | | | | | | | | | | | | | | | | | | | | | | | | | | | | | | | | | | | | | | | | | | | | | | | | | | | | | | | | | | | | | | | | | | | | | | | | | | | | | | | | | | | | | | | | | | | | | | | | | | | | | | | | | | | | | | | | | | | | | | | | | | | | | | | | | | | | |
| Extra C - Full - Graustein - Hike | | | | | | | | | | | | | | | | | | | | | | | | | | | | | | | | | | | | | | | | | | | | | | | | | | | | | | | | | | | | | | | | | | | | | | | | | | | | | | | | | | | | | | | | | | | | | | | | | | | | | | | | | | | | | | | | | | | | | | | | | | | | | | | | | | | | | | | | | | | | | | | | | | | | | | | | | | | | | | | | | | | | | | | | | | | | |
| I.Mat - Join - Key_Mood - Life | | | | | | | | | | | | | | | | | | | | | | | | | | | | | | | | | | | | | | | | | | | | | | | | | | | | | | | | | | | | | | | | | | | | | | | | | | | | | | | | | | | | | | | | | | | | | | | | | | | | | | | | | | | | | | | | | | | | | | | | | | | | | | | | | | | | | | | | | | | | | | | | | | | | | | | | | | | | | | | | | | | | | | | | | | | | |
| Materica - Meet - One - Portraits | | | | | | | | | | | | | | | | | | | | | | | | | | | | | | | | | | | | | | | | | | | | | | | | | | | | | | | | | | | | | | | | | | | | | | | | | | | | | | | | | | | | | | | | | | | | | | | | | | | | | | | | | | | | | | | | | | | | | | | | | | | | | | | | | | | | | | | | | | | | | | | | | | | | | | | | | | | | | | | | | | | | | | | | | | | | |
| Prima - Quartz Essence - Roxstones | | | | | | | | | | | | | | | | | | | | | | | | | | | | | | | | | | | | | | | | | | | | | | | | | | | | | | | | | | | | | | | | | | | | | | | | | | | | | | | | | | | | | | | | | | | | | | | | | | | | | | | | | | | | | | | | | | | | | | | | | | | | | | | | | | | | | | | | | | | | | | | | | | | | | | | | | | | | | | | | | | | | | | | | | | | | |
| Slab - Shapes of Italy - Tale - Vibe | | | | | | | | | | | | | | | | | | | | | | | | | | | | | | | | | | | | | | | | | | | | | | | | | | | | | | | | | | | | | | | | | | | | | | | | | | | | | | | | | | | | | | | | | | | | | | | | | | | | | | | | | | | | | | | | | | | | | | | | | | | | | | | | | | | | | | | | | | | | | | | | | | | | | | | | | | | | | | | | | | | | | | | | | | | | |
| Aextra30 | 360 | | | | | | | | | | | | | | | | | | | | | | | | | | | | | | | | | | | | | | | | | | | | | | | | | | | | | | | | | | | | | | | | | | | | | | | | | | | | | | | | | | | | | | | | | | | | | | | | | | | | | | | | | | | | | | | | | | | | | | | | | | | | | | | | | | | | | | | | | | | | | | | | | | | | | | | | | | | | | | | | | | | | | | | | | | | |
| Extra C - Tale | | | | | | | | | | | | | | | | | | | | | | | | | | | | | | | | | | | | | | | | | | | | | | | | | | | | | | | | | | | | | | | | | | | | | | | | | | | | | | | | | | | | | | | | | | | | | | | | | | | | | | | | | | | | | | | | | | | | | | | | | | | | | | | | | | | | | | | | | | | | | | | | | | | | | | | | | | | | | | | | | | | | | | | | | | | | |
| Project Evolution | 366 | | | | | | | | | | | | | | | | | | | | | | | | | | | | | | | | | | | | | | | | | | | | | | | | | | | | | | | | | | | | | | | | | | | | | | | | | | | | | | | | | | | | | | | | | | | | | | | | | | | | | | | | | | | | | | | | | | | | | | | | | | | | | | | | | | | | | | | | | | | | | | | | | | | | | | | | | | | | | | | | | | | | | | | | | | | |
| Anima - Anima Ever - Anima Futura | | | | | | | | | | | | | | | | | | | | | | | | | | | | | | | | | | | | | | | | | | | | | | | | | | | | | | | | | | | | | | | | | | | | | | | | | | | | | | | | | | | | | | | | | | | | | | | | | | | | | | | | | | | | | | | | | | | | | | | | | | | | | | | | | | | | | | | | | | | | | | | | | | | | | | | | | | | | | | | | | | | | | | | | | | | | |
| Alchemy - Join - Portraits - Prima | | | | | | | | | | | | | | | | | | | | | | | | | | | | | | | | | | | | | | | | | | | | | | | | | | | | | | | | | | | | | | | | | | | | | | | | | | | | | | | | | | | | | | | | | | | | | | | | | | | | | | | | | | | | | | | | | | | | | | | | | | | | | | | | | | | | | | | | | | | | | | | | | | | | | | | | | | | | | | | | | | | | | | | | | | | | |
| Relate Flame - Shapes of Italy | | | | | | | | | | | | | | | | | | | | | | | | | | | | | | | | | | | | | | | | | | | | | | | | | | | | | | | | | | | | | | | | | | | | | | | | | | | | | | | | | | | | | | | | | | | | | | | | | | | | | | | | | | | | | | | | | | | | | | | | | | | | | | | | | | | | | | | | | | | | | | | | | | | | | | | | | | | | | | | | | | | | | | | | | | | | |
| Tinte Unite | | | | | | | | | | | | | | | | | | | | | | | | | | | | | | | | | | | | | | | | | | | | | | | | | | | | | | | | | | | | | | | | | | | | | | | | | | | | | | | | | | | | | | | | | | | | | | | | | | | | | | | | | | | | | | | | | | | | | | | | | | | | | | | | | | | | | | | | | | | | | | | | | | | | | | | | | | | | | | | | | | | | | | | | | | | | |
| Olos | 384 | | | | | | | | | | | | | | | | | | | | | | | | | | | | | | | | | | | | | | | | | | | | | | | | | | | | | | | | | | | | | | | | | | | | | | | | | | | | | | | | | | | | | | | | | | | | | | | | | | | | | | | | | | | | | | | | | | | | | | | | | | | | | | | | | | | | | | | | | | | | | | | | | | | | | | | | | | | | | | | | | | | | | | | | | | | |

Materia per i tuoi progetti

Material for your projects · De la matière pour vos projets
Materie für ihre projekte · Материал для ваших проектов

La nostra storia parte dal 1988 come specialisti di una materia, il grès porcellanato, superficie votata all'eccellenza tecnica che appaga l'occhio con la sua bellezza, frutto della nostra esperienza, ricerca, tecnologia. Una storia italiana, apprezzata in tutto il mondo, che parla di attenzione all'ambiente e alla sicurezza, di attitudine al design e di soluzioni al servizio dell'architettura. Questa storia fa parte della nostra cultura: ogni giorno si articola in mille trame diverse e trova compimento solo quando diventa parte del tuo progetto di design. I tuoi progetti riflettono le tue scelte, la tua creatività, il tuo modo di essere: meritano prodotti alla loro altezza. Caesar è materia per i tuoi progetti.

Our story begins as specialists in a material, porcelain tiles, surfaces devoted to technical excellence and satisfying on the eye with their beauty; the result of our experience, research and technology. An Italian story, appreciated the world over, that talks about attention to the environment and safety, an aptitude for design and architecture solutions. This story is part of our culture: every day it is divided into a thousand different themes and finds fulfilment only when it becomes part of your design project. Your projects reflect your choices, your creativity, your way of being: they deserve products to match. Caesar is the material for your projects.

Notre histoire commence en tant que spécialistes d'une matière, le grès cérame, surface vouée à l'excellence technique, et dont la beauté, fruit de notre expérience, recherche et technologie, fait du bien aux yeux. Une histoire italienne, appréciée dans le monde entier, qui parle d'attention envers l'environnement et la sécurité, d'aptitude envers le design et de solutions au service de l'architecture. Cette histoire fait partie de notre culture : chaque jour, elle s'articule autour de mille motifs différents et elle ne s'accomplit que quand elle fait partie de votre projet design. Vos projets reflètent vos choix, votre créativité, votre manière d'être, qui méritent des produits à la hauteur de leur valeur. Caesar, c'est de la matière pour vos projets

Unsere Geschichte beginnt mit der Materie, dem Feinsteinzeug. Eine technisch überragende Materie, die mit ihrer Schönheit besticht. Sie ist Ergebnis unserer Erfahrung, Forschung, Technologie. Eine ganz italienische Geschichte, die in aller Welt geschätzt wird. Die von Respekt für Umwelt und Sicherheit zeugt, von Designbewusstsein und von Lösungen für die Architektur. Diese Geschichte ist Teil unserer Kultur: Tag für Tag entsteht sie aus tausend verschiedenen Motiven, und erst im Rahmen Ihres Designprojekts findet sie ihren Abschluss. Ihre Projekte reflektieren Ihre Ideen, Ihre Kreativität, Ihren Stil - sie verdienen Produkte, die ihnen gerecht werden. Caesar ist Materie für Ihre Projekte.

Отправной точкой в нашей истории является специализация в таком материале, как керамогранит, - поверхности, идеальной с технической точки зрения и радующей глаз своей красотой, являющейся результатом нашего опыта, поисков и технологии. Это - итальянская история, по достоинству оцененная во всем мире, рассказывает о бережном отношении к окружающей среде, принципах дизайна и архитектурных решениях. Эта история составляет часть нашей культуры: каждый день она дополняется различными сюжетами и заканчивается лишь тогда, когда находит воплощение в твоём проекте дизайна. Твои проекты - это отражения твоего выбора, твоей креативности, твоего жизненного кредо: они заслуживают продуктов под стать себе. Цезарь - это материал для твоих проектов.

**Dal 1988 eccellenza
nella produzione
del grès porcellanato**

Since 1988 excellence
in porcelain grès production

**Oltre 200 mln m²
venduti in tutto il mondo**

Over 200 mln sqm
sold worldwide

**200.000 m²
area industriale**

200,000 sqm industrial area



Il grès porcellanato Caesar

Caesar porcelain tiles · Le grès cérame Caesar
Das Feinsteinzeug von Caesar · керамогранит Caesar

Il grès porcellanato è la scelta ideale per dare forma, sostanza e una prospettiva di lunga durata alle tue idee. Perché è una materia estremamente compatta e duttile, contraddistinta da bassissimi valori di assorbimento. Qualità ineguagliabili, che la rendono eccezionalmente resistente, oltre che igienica e sicura, visto che non rilascia sostanze nocive, e totalmente riciclabile, perché prodotta al 100% con materie prime naturali. Un mix vincente di vantaggi per coniugare prestazioni tecniche di livello assoluto con un'altissima resa stilistica nei più svariati contesti: dagli spazi residenziali e commerciali, indoor e outdoor, ai luoghi pubblici ad elevata frequentazione, tra cui alberghi, ospedali, stazioni, aeroporti, piazze e centri commerciali.

Porcelain tiles are the ideal choice to give shape to your ideas, substance and the prospect of a long life. This is because this material is compact and ductile, and distinguished by extremely low absorption values. These unrivalled qualities make it exceptionally hard-wearing as well as hygienic and safe, considering the fact that it does not release any harmful substances, and is totally recycled, as it is produced 100% with natural raw materials. This winning mix of advantages blends top-level technical performance with superior styling appeal in a wide variety of contexts: residential and commercial settings, both indoor and outdoor, as well as high traffic public venues, including hotels, hospitals, stations, airports, city squares and shopping centres.

Le grès cérame est le choix idéal pour donner forme, substance et une perspective de longue durée de vie à vos idées. Il s'agit d'un matériel extrêmement compact et malléable, caractérisé par des valeurs d'absorption très faibles. Des qualités incomparables qui le rendent extrêmement résistant, en plus d'être hygiénique et sûr car il n'émet pas de substances nocives, et entièrement recyclable car il est produit à 100 % avec des matières premières naturelles. Une combinaison gagnante d'avantages pour assurer des performances techniques de très haut niveau et un rendu stylistique élevé dans les contextes les plus différents : des espaces résidentiels et commerciaux, intérieurs et extérieurs, aux espaces publics à forte fréquentation, par exemple des hôtels, hôpitaux, gares, aéroports, places et centres commerciaux.

Feinsteinzeug ist genau das Richtige, um Ihren Ideen Form, Substanz und ein langes Leben zu geben. Es handelt sich um ein extrem kompaktes und anpassungsfähiges Material mit äußerst niedriger Wasseraufnahme. Unvergleichliche Eigenschaften machen es allen Belastungen gegenüber widerstandsfähig und dazu sicher und hygienisch. Es gibt keine Schadstoffe ab und ist hundertprozentig recyclebar, denn es besteht zu 100% aus natürlichen Rohstoffen. Ein unschlagbarer Mix aus Vorteilen, die technische Leistungen von höchstem Niveau und stilvoll in jedem Umfeld vereinen: Im Wohnungs- und Gewerbebau, in Innen- und Außenbereichen, in stark besuchten öffentlichen Einrichtungen wie Hotels, Krankenhäusern, Bahnhöfen, Flughäfen, Plätzen und Einkaufszentren.

Керамогранит – это идеальный выбор для того, чтобы ваши идеи обрели форму, содержание и долгосрочную перспективу. Это невероятно компактный и пластичный материал, который характеризуется крайне низким показателем влаговпитываемости. Непревзойденные свойства керамогранита делают его исключительно прочным, гигиеничным и безопасным материалом, который не выделяет вредных веществ. Керамогранит полностью подлежит переработке, поскольку производится на 100% из натурального сырья. Плитка из керамогранита – это выигрышное сочетание технические характеристики высочайшего уровня и качественной долговечной стилистики в самых разнообразных контекстах: от жилых и коммерческих, внутренних и наружных пространств до часто посещаемых общественных мест, включая отели, больницы, станции, аэропорты, площади и торговые центры.

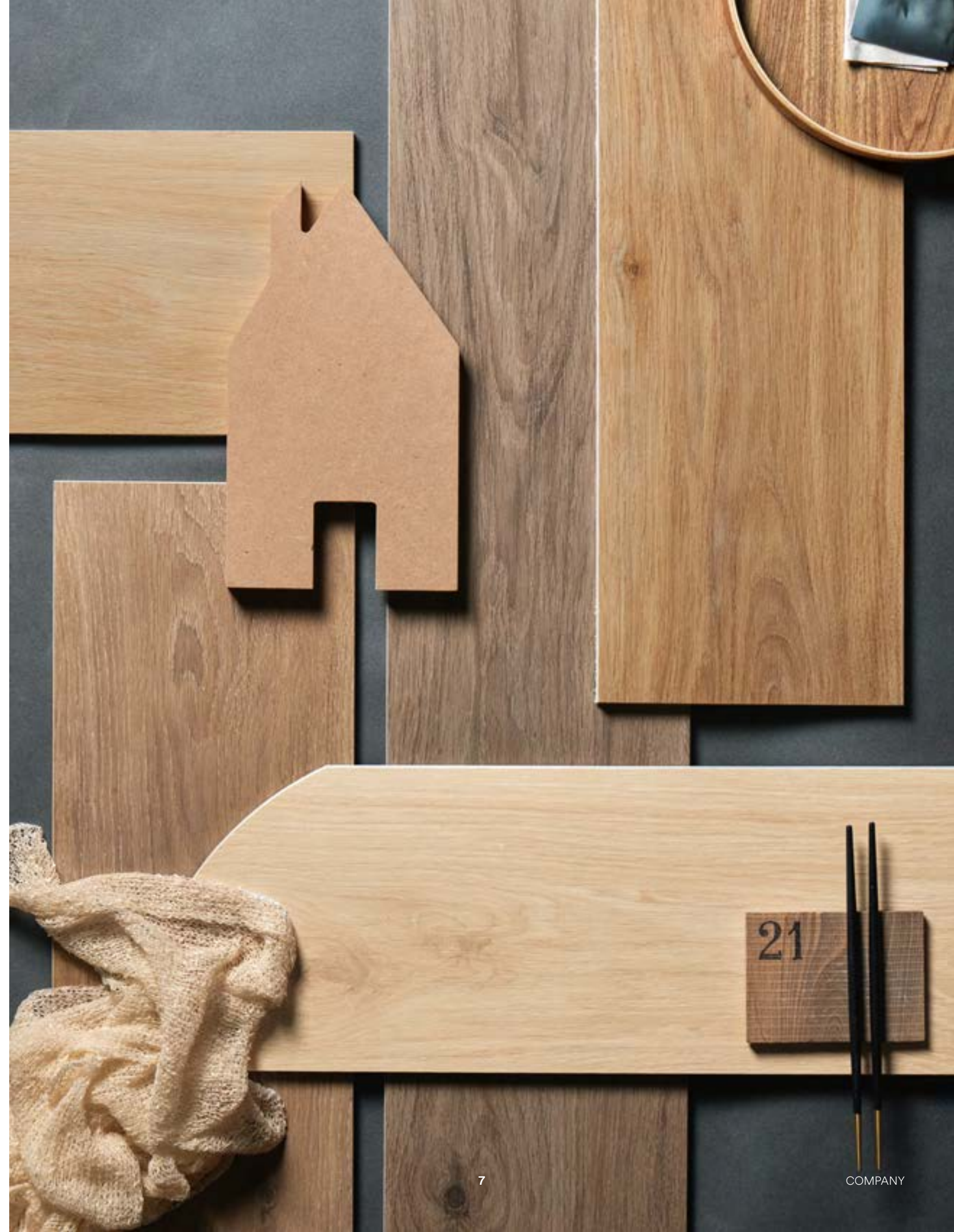

Qualità e tecnologia

Quality and technology - Qualité et technologie
Qualität und Technologie · Высокое качество и технологичность

La principale peculiarità del grès porcellanato è di essere un materiale estremamente compatto, frutto di operazioni tecnologiche di pressatura meccanica e cottura ad altissimi livelli. Da ciò derivano valori di assorbimento tendenti allo 0 che lo rendono estremamente resistente ai più svariati tipi di sollecitazioni (usura, graffi, macchie, etc.), facendone la materia di rivestimento ideale in qualsiasi tipo di ambiente, in interno ed esterno, anche in presenza di elevati e frequenti volumi di calpestio e traffico.

The most striking feature of porcelain stoneware is its compactness, which is the result of top level mechanical pressing and firing technology. This feature offers absorption values near to zero and makes this material particularly resistant to the most diverse types of stress (wear, scratching, staining, etc.). It makes porcelain stoneware the ideal covering material for any type of environment, indoors and outdoors, and for the heaviest traffic conditions.

La principale particularité du grès cérame est celle d'être extrêmement compact, est issu d'opérations technologiques de pressage mécanique et de cuisson à très hauts niveaux. Résultat, sa valeur d'absorption proche de zéro le rend extrêmement résistant aux sollicitations les plus diverses (usure, rayures, taches, etc.) et en fait le revêtement universel idéal, pour l'intérieur comme pour l'extérieur, y compris en présence de circulation et de passage fréquents et importants.

Hauptmerkmal des Feinsteinzeugs ist die durch Press- und Brennprozesse von höchstem technologischem Niveau erreichte, extreme Festigkeit. Damit werden Absorptionswerte von nahezu 0 erreicht, die eine extreme Beständigkeit gegen verschiedenste Belastungen (Abnutzung, Kratzer, Flecken etc.) garantieren und den Einsatz in Räumen jeder Art erlauben, innen wie außen, selbst für intensivste Beanspruchung durch Begehen und Befahren.

Его основная особенность - это чрезвычайная плотность материала, являющаяся результатом технологических операций механического прессования и обжига при очень высокой температуре. Эти операции обуславливают почти что нулевое поглощение влаги, что делает керамогранит чрезвычайно стойким к всем типам воздействия (износ, царапины, пятна и т.д.) и превращает его в великолепный облицовочный материал для пространств любого типа, как внутренних, так и наружных, даже при наличии высокой интенсивности хождения и движения.



Facile da pulire
Easy to clean



Resiste al gelo
It is frostproof



Igienico e sicuro
Hygienic and safe



Resiste ad abrasioni ed usure
It is abrasion and wear-resistant



Facile da installare
Easy to install



Resiste ai carichi e alle sollecitazioni
It resists loading and stress



Resiste agli sbalzi termici
It resists thermal shocks



Inalterabile alla luce
It is colourfast



Inalterabile alle alte temperature
It resists high temperatures



Non rilascia sostanze nocive
It does not release harmful substances



Resiste allo smog e agenti inquinanti
It resists smog and other polluting agents

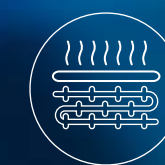

È compatibile con il riscaldamento a pavimento
It is suitable for heated floors

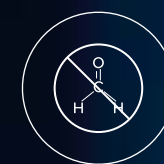

Non contiene plastica e amianto e non rilascia formaldeide
It does not contain plastic or asbestos, or release formaldehyde



Resiste agli agenti chimici di uso domestico e industriale
It resists both household and industrial chemicals



Non reagisce al fuoco: non produce gas tossici in caso di incendi
Fire resistant: it does not emit toxic gas in the event of fire



È privo di impermeabilizzanti chimici, vernici o resine
It does not contain chemical waterproofing agents, paint or resin

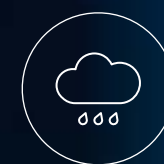

Inalterabile all'acqua e all'umidità
It resists water and damp

Ampiezza e versatilità

Amplitude and versatility · Étendue et polyvalence
Sortimentsbreite und vielseitigkeit · Разнообразие и универсальность

Le potenzialità del grès porcellanato in una gamma studiata e costantemente aggiornata per esprimere tutto il tuo potenziale. Affidandoti a noi, puoi contare su oltre 2.000 articoli: una ricca e completa varietà di formati, colori, spessori e soluzioni differenziate, in linea con i trend più attuali. Un catalogo composto da collezioni innovative ed eleganti, piacevoli al tatto e di facile manutenzione, resistenti al tempo e al passare delle mode. Proposte accattivanti, pensate per accompagnarti nel tempo, garantendo l'equilibrio perfetto tra prestazioni e resa estetica in tutte le sfide progettuali. Compresse le più complesse, anche grazie alla serie dei grandi formati Project Evolution, alle soluzioni tecniche di CaesarTech e a quelle per esterno di Aextra20 e Aextra30.

The potential of porcelain tiles in a carefully devised and constantly updated range to express your full potential. By choosing us, you can count on more than 2,000 articles: a rich and comprehensive variety of sizes, colours, thickness versions and differentiated solutions, in line with the latest trends. A catalogue that comprises innovative and elegant collections, which are pleasant to touch and easy to maintain, durable and which will hardly go out of fashion. Attractive offerings, designed to accompany you over time, striking the perfect balance between performance and styling appeal in all design challenges. Including the most complex ones, also thanks to the series of Project Evolution large sizes, to the CaesarTech technical solutions and the outdoor series Aextra20 and Aextra30.

Toute la force du grès cérame dans une gamme étudiée et actualisée en permanence pour exprimer votre potentiel. En nous faisant confiance, vous pouvez compter sur plus de 2 000 articles : une variété de formats, de couleurs, d'épaisseurs et de solutions personnalisées, riches et variées, en accord avec les tendances les plus actuelles. Un catalogue composé de collections innovantes et élégantes, agréables au toucher et faciles à entretenir, résistantes au temps et aux modes passagères. Des propositions captivantes, conçues pour vous accompagner durablement, en garantissant l'équilibre parfait entre performances et aspect esthétique dans tous les défis liés à la conception, notamment les plus complexes, grâce également à la série des grands formats Project Evolution, aux solutions techniques de CaesarTech et celles pour l'extérieur d'Aextra20 et Aextra30.

Das Potenzial des Feinsteinzeugs entfaltet sich in einer Produktpalette, die darauf ausgelegt und stetig aktualisiert wird, um Ihr ganzes Potenzial zum Ausdruck zu bringen. Mit uns stehen Ihnen mehr als 2.000 Artikel zur Wahl: Eine reiche und vollständige Auswahl aus Farben und Formaten, differenzierten Stärken und Lösungen, die ganz den aktuellsten Trends entsprechen. Der Katalog umfasst innovative und elegante Kollektionen, Produkte, die sich angenehm anfühlen und pflegeleicht sind, die Zeiten und Moden überdauern. Attraktive Ideen, die Sie auf lange Zeit begleiten und ein perfektes Gleichgewicht aus Leistung und Optik für jede planerische Herausforderung garantieren. Einschließlich der komplexesten: auch dank der Serie der Großformate Project Evolution, der technischen Lösungen von CaesarTech und jener für Außenbereiche Aextra20 und Aextra30.

Весь потенциал керамогранита раскрывается в специальной постоянно обновляющейся гамме, которая позволит максимально полно выразить ваш потенциал. Положившись на нас, вы можете рассчитывать на более чем 2000 видов плитки с широким разнообразием форматов, цветов, толщины и различных решений, соответствующих самым современным тенденциям. Каталог, состоящий из инновационных и элегантных коллекций, приятных на ощупь, простых в уходе и устойчивых ко времени и моде. Захватывающие предложения, разработанные, чтобы сопровождать вас в течение долгого времени, обеспечивая идеальный баланс между функциональностью и эстетической привлекательностью в любых проектах. Даже самые сложные проекты можно осилить благодаря коллекции плитки больших форматов Project Evolution, техническим решениям плитки CaesarTech и плитки для наружных пространств Aextra20 и Aextra30.

Oltre 2.000 articoli

More than 2.000 articles

Più di 40 formati

Over 40 different sizes

Più di 200 colori

More than 200 colours

7 spessori

7 thicknesses

7 finiture

7 finishes



Prodotti, soluzioni e servizi per il Design

Products, solutions and services for Design · Produits, solutions et services pour le design · Produkte, Lösungen und Leistungen im Dienst des Designs
Продукты, решения и услуги в области дизайна

Vestire gli spazi con il design a loro più congeniale è un'arte che richiede competenze e sensibilità. Per questo, la nostra ampia offerta di soluzioni, in linea con le tendenze più attuali, è pensata e composta per rispondere alle più svariate esigenze. Dalle pose a pavimento e rivestimento, ai più recenti interventi di arredo e personalizzazione, per i quali abbiamo sviluppato gamme altamente dedicate. Tra queste, le grandi lastre Project Evolution, ideali per creare effetti di affascinante continuità estetica, i prodotti della linea Deco Solutions, ideali per proporre un design dall'alto potenziale cromatico e decorativo, anche attraverso progetti on demand. E le lastre di Olos, per creare piani di lavoro, arredi per bagni e cucine e allestimenti su misura. Infine, per aiutarvi a realizzare pienamente le vostre visioni, Cross Design, utilizzabile per trovare sempre le giuste armonie tra materie, colori e grafiche.

Dressing spaces with the design that suits them best is an art that requires skill and sensitivity. Therefore, our wide range of solutions, in line with the latest trends, is designed and composed to meet the most diverse requirements. From floor and wall applications to the latest in furniture and customisation, for which we have developed bespoke ranges. These include the Project Evolution large slabs, ideal for creating effects of fascinating aesthetic continuity, and the products of the Deco Solutions line, ideal for proposing a design with high chromatic and decorative potential, also through on-demand projects. And Olos slabs, to create worktops, bathroom and kitchen furniture and customised fittings. And also, to help you fully realise your visions, Cross Design can be used to always find the right harmonies between materials, colours and graphics.

Revêtir les espaces avec le design qui leur convient le mieux est un art qui nécessite des compétences et une certaine sensibilité. Pour cela, notre large offre de solutions, qui suit les tendances les plus actuelles, est étudiée et composée pour répondre aux exigences les plus variées, des poses au sol ou en revêtement mural aux interventions de décoration et personnalisation plus récentes, pour lesquelles nous avons développé des gammes véritablement dédiées. Entre autres, les grandes dalles Project Evolution, idéales pour créer des effets d'une continuité esthétique fascinante, les produits de la gamme Deco Solutions, parfaits pour proposer un design à fort potentiel chromatique et décoratif, même sur des projets à la demande, sans oublier les dalles d'Olos, pour créer des plans de travail, des meubles de salle de bains et des cuisines et des aménagements sur mesure. Enfin, pour vous aider à réaliser pleinement vos idées, Cross Design pourra être utilisée pour trouver les harmonies les plus justes entre matières, couleurs et graphismes.

Räume mit dem Design zu kleiden, das ihnen am besten steht, ist eine Kunst, die Sensibilität und Kompetenz verlangt. Deshalb umfasst unser breites Sortiment den aktuellsten Trends entsprechende Lösungen, die auch den unterschiedlichsten Ansprüchen gerecht werden. Von der Verlegung an Wand und Boden bis zu den neuesten Ideen in Sachen Einrichtung und Personalisierung, für die wir jeweils spezifische Sortimente entwickelt haben. Zu diesen gehören die großen Platten Project Evolution, die zur Erzeugung faszinierend einheitlicher, optischer Effekte ideal sind, und Produkte der Linie Deco Solutions für ein Design mit hohem Farb- und Dekorationspotenzial, auch im Rahmen kundenspezifischer Projekte. Dazu die Platten Olos für Arbeitsflächen und Einrichtungs-elemente in Küche und Bad sowie für Einrichtungen nach Maß. Und schließlich Cross Design, mit dem Sie Ihre Visionen voll verwirklichen können und stets die richtige Harmonie aus Materialien, Farben und Mustern finden.

Оформлять пространства в наиболее подходящем для них дизайне - это искусство, требующее опыт и чуткость. Именно чтобы удовлетворить самым разнообразным требованиям, нами была разработана широкая линейка решений, отвечающая последним тенденциям. Речь идет о специальных коллекциях напольной и настенной плитки, которые могут использоваться для персонализации интерьера. К ним относятся крупноформатные плиты Project Evolution, которые идеально подходят для эффекта эстетической целостности и непрерывности, а также продукция линейки Deco Solutions, обладающая высоким хроматическим и декоративным потенциалом, в том числе в рамках проектов по заказу. Равно как и крупноформатные плиты проекта Olos для создания рабочих поверхностей, мебели для ванных комнат и кухни, а также облицовки согласно размерам заказчика. Наконец, чтобы в полной мере воплотить собственные замыслы, можно обратиться к коллекции Cross Design, позволяющей добиться гармонии между материалом, цветами и графикой.



Una grande storia italiana

A great all-italian story · Une grande histoire italienne
Eine italienische Erfolgsgeschichte · Великая итальянская история

La nostra è una grande storia italiana, fatta di anni di passione e perfezionamento per realizzare prodotti che siano massima espressione del Made in Italy. Una tradizione in continua innovazione, fatta di creatività, ingegno e maestria nei campi della moda, del gusto, della cultura. Ma anche dell'arte: Material 4 Arts è la raccolta di progetti con cui Caesar ha promosso diverse forme d'arte, dal cinema alla fotografia, dai contest alle performance, alla ricerca di punti di vista inediti sul design e la materia. Questa è la storia che tramandiamo in tutto il mondo, presidiando a livello commerciale oltre 100 Paesi, coniugando visione, ascolto e relazione, con l'intento di cogliere e interpretare nel migliore dei modi le più complesse sfumature culturali.

Ours is a great Italian story, made up of years of passion and refinement to create products that are the ultimate expression of Made in Italy. Tradition subjected to continuous innovation, made up of creativity, mastery and expertise in the fields of fashion, style and culture. But also of art: Material 4 Arts is the collection of projects with which Caesar has promoted various forms of art, from film to photography, from contests to performances, in search of new points of view on design and material. This is the story which we take all over the world, with a commercial presence in more than 100 different countries, combining viewing, listening and relating, with the intention of capturing and interpreting in the best possible way the most complex cultural nuances.

Notre grande histoire italienne repose sur des années de passion et de perfectionnement pour réaliser des produits qui reflètent au maximum le Made in Italy. Une tradition en constante évolution, faite de créativité, de génie et de maîtrise dans les domaines de la mode, du goût et de la culture. Mais aussi de l'art : Material 4 Arts est la collection de projets avec lesquels Caesar a encouragé diverses formes d'art, du cinéma à la photographie, en passant par les télécrochets et spectacles, à la recherche de points de vue inédits sur le design et la matière. C'est cette histoire que nous diffusons dans le monde entier, en étant présents au niveau commercial dans plus de 100 pays et en associant vision, écoute et relation, dans l'intention de cueillir et d'interpréter du mieux possible les nuances culturelles les plus complexes.

Unsere Geschichte ist jene eines großen italienischen Erfolgs, von Jahren voller Leidenschaft und kontinuierlicher Verbesserung, und von Produkten, die das Made in Italy perfekt zum Ausdruck bringen. Eine sich ständig erneuernde Tradition aus Kreativität, Erfindergeist und Meisterschaft in Mode, gutem Geschmack und Kultur. Und auch aus Kunst: Material 4 Arts ist eine Sammlung aus Projekten, mit denen Caesar verschiedene Kunstformen gefördert hat, vom Kino zur Fotografie, von Wettbewerben bis zu Performances und zu Studien über ungewöhnliche Perspektiven auf Design und Materie. Das ist die Geschichte, die wir in die ganze Welt tragen, in die mehr als 100 Länder, in denen unser Vertrieb Visionen, Dialog und Interaktion vereint, um auch die komplexesten kulturellen Nuancen zu erkennen und zu interpretieren.

Наша история - это славная история итальянских традиций, сотканная из годов самоотверженной работы и усовершенствования, и это позволяет нам производить материалы, в полной мере соответствующий концепции Made in Italy. Это традиция, находящаяся в постоянном усовершенствовании, возвращенная на креативности, оригинальности мышления и виртуозности в области моды, вкуса, культуры. А еще и искусства: Material 4 Arts - это подборка программ, посредством которых компания продвигала различные формы искусства, от кино до фотографии, от конкурсов до перформансов, в поисках новых точек зрения на дизайн и материалы. Это история, которую мы транслируем на весь мир, предлагая свою продукцию в более чем 100 странах, присматриваясь, прислушиваясь и взаимодействуя с людьми с целью уловить и наилучшим образом интерпретировать самые сложные культурные нюансы.



Every day counts

Ogni giorno le nostre scelte contano e fanno la differenza, misurando il nostro reale impegno per la tutela dell'ambiente e il miglioramento della qualità della vita. Per questo siamo costantemente al lavoro per creare prodotti buoni per la natura e le persone, producendo ceramiche di eccellenza con processi improntati alla massima sostenibilità; investendo costantemente per ridurre consumi, sprechi, scarti ed emissioni; creando le condizioni per garantire la massima sicurezza e il benessere dei lavoratori, e sostenendo iniziative a carattere sociale e culturale per favorire la crescita e lo sviluppo della nostra comunità locale.

Every day our choices matter and make a difference, measuring our real commitment to protecting the environment and improving the quality of life. That is why we are constantly working to create products that are good for nature and people, producing ceramics of excellence with processes geared to maximum sustainability; constantly investing to reduce consumption, waste and emissions; creating the conditions to ensure maximum safety and wellbeing for workers; and supporting social and cultural initiatives to foster the growth and development of our local community.

Chaque jour, nos choix comptent et font la différence, en mesurant notre réel engagement dans la protection de l'environnement et l'amélioration de la qualité de vie. Pour cela, nous travaillons d'arrache-pied pour créer des produits bons pour la nature et les personnes, en fabricant des céramiques d'excellence avec des processus orientés vers une durabilité maximale, en investissant en permanence pour réduire les consommations, les gaspillages, les déchets et les émissions, en créant les conditions pour garantir une sécurité maximale et le bien-être des travailleurs et en soutenant des initiatives à caractère social et culturel pour favoriser la croissance et le développement de notre communauté locale.

Jede Entscheidung zählt, Tag für Tag, und zeugt von unserem konkreten, messbaren Engagement für den Schutz der Umwelt und für eine bessere Lebensqualität. Deshalb arbeiten wir kontinuierlich daran, Produkte zu entwickeln, die gut für Mensch und Natur sind und produzieren Keramik von exzellenter Qualität mit Verfahren, die im Zeichen maximaler Nachhaltigkeit stehen. Wir investieren immer weiter, um Verbrauch, Verschwendung, Abfall und Emissionen zu reduzieren. Wir schaffen die Voraussetzungen für maximale Sicherheit und das Wohlbefinden der Arbeitnehmer, und unterstützen soziale und kulturelle Initiativen zur Förderung von Wachstum und Entwicklung unserer lokalen Gemeinschaft.

Изо дня в день наш выбор имеет значение и приносит пользу, измеряя нашу реальную заботу о защите окружающей среды и улучшении качества жизни. Именно поэтому мы постоянно работаем над созданием продукции, не приносящей вред природе и людям, производим керамику высочайшего качества с использованием процессов, направленных на максимальную устойчивость; постоянно инвестируем в сокращение потребления, отходов и выбросов; создаем условия для обеспечения максимальной безопасности и благополучия работников; поддерживаем социальные и культурные инициативы, способствующие росту и развитию нашего местного сообщества.

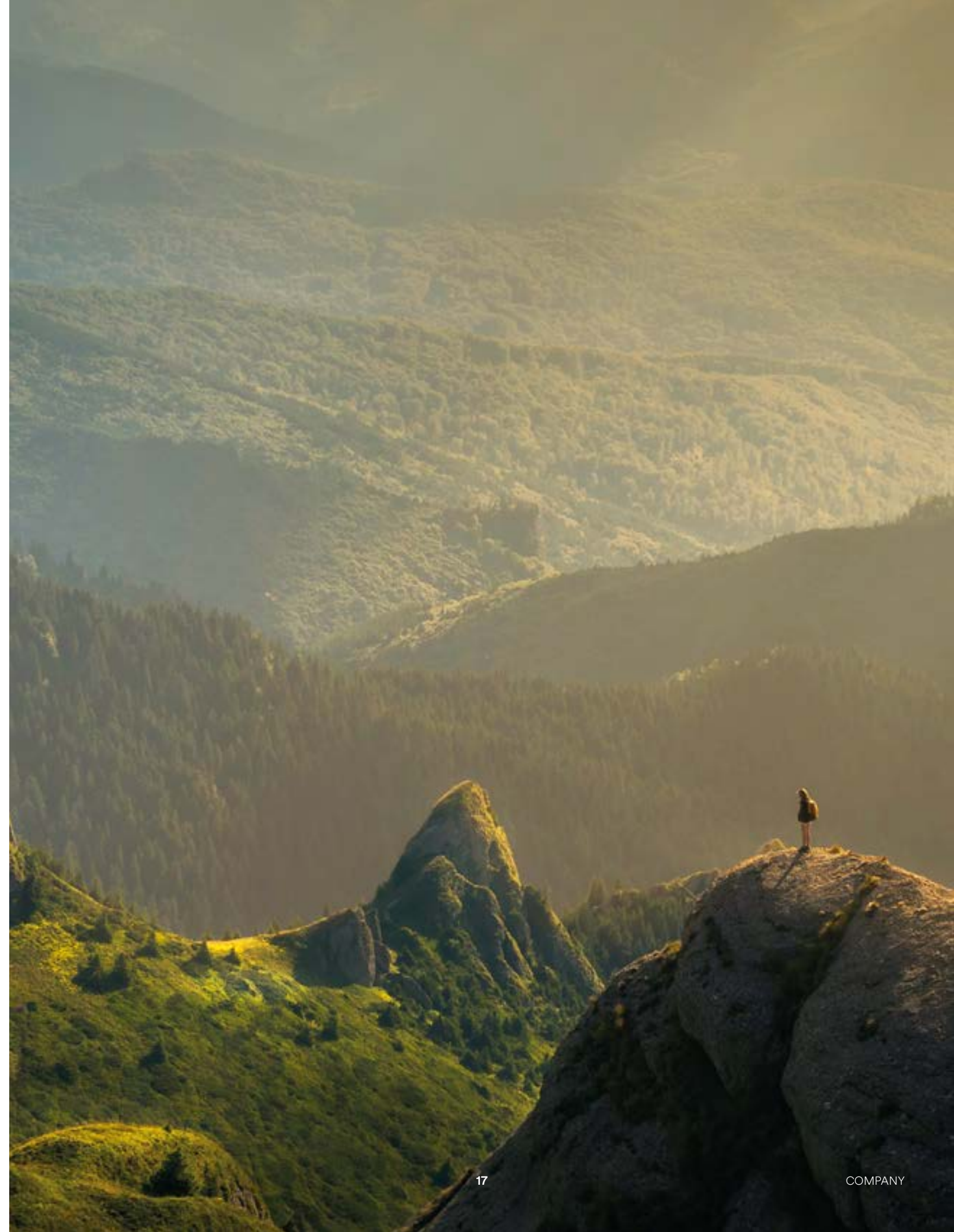

Attitudine per il riciclo e la circolarità

Attitude for recycling and circularity · Engagement vers le recyclage et l'économie circulaire · Wir legen Wert auf Recycling und Kreislaufwirtschaft · Приверженность к вторичной переработке и экономике замкнутого цикла

Il modello di economia circolare è un riferimento per il nostro operato. I nostri processi industriali si orientano alla salvaguardia dell'ambiente, riducendo al minimo il consumo di materie prime e risorse naturali. Siamo in grado di riciclare il 100% degli scarti crudi e cotti reimmettendoli in produzione; riutilizziamo il 100% delle acque e differenziamo la raccolta di tutti i rifiuti. Un innovativo impianto di cogenerazione ad alta efficienza e un vasto campo fotovoltaico di prossima realizzazione contribuiscono al risparmio energetico complessivo. Continue opere di efficientamento e riduzione delle emissioni, così come le innovazioni a livello logistico, migliorano costantemente l'impatto ambientale del nostro sito industriale. Il nostro stesso prodotto è qualificabile come circolare: il grès Caesar è estremamente longevo, e al termine del suo ciclo di vita può essere riciclato per nuovi utilizzi.

The circular economy model is a reference for our work. We protect the environment through our industrial processes, by minimising the consumption of raw materials and natural resources. We can recycle 100 per cent of raw and fired scraps by feeding it back into production; we reuse 100% of the water and separate the collection of all waste. An innovative high-efficiency cogeneration plant and a large photovoltaic field soon to be built contribute to the overall energy savings. Continuous efficiency and emission reduction works, as well as innovations in logistics, constantly improve the environmental impact of our industrial site. Our product itself qualifies as circular: Caesar stoneware is extremely durable, and at the end of its life cycle it can be recycled for new uses.

Le modèle d'économie circulaire est une référence dans notre façon de travailler. Nos processus industriels s'orientent vers la protection de l'environnement, en réduisant au minimum la consommation de matières premières et de ressources naturelles. Nous sommes capables de recycler 100 % des déchets crus et cuits en les réinjectant dans la production ; nous réutilisons 100 % des eaux et trions la totalité de nos déchets. La création prochaine d'un système innovant de cogénération haute efficacité et d'une vaste installation photovoltaïque vont contribuer aux économies d'énergie globales. Des travaux permanents d'accroissement de l'efficacité et de réduction des émissions, de même que les innovations sur le plan logistique, améliorent en permanence l'impact environnemental de notre site industriel. Notre produit peut être qualifié de 'circulaire' : le grès Caesar est extrêmement durable et, à la fin de son cycle de vie, il peut être recyclé pour de nombreuses utilisations.

Das Modell der Kreislaufwirtschaft ist ein Maßstab, an dem wir uns in unserem Handeln orientieren. Unsere Produktionsverfahren zielen auf den Schutz der Umwelt ab, indem sie den Verbrauch von Rohstoffen und natürlichen Ressourcen auf das Minimum reduzieren. Wir sind in der Lage, 100 % unseres vor und nach dem Brennen anfallenden Ausschusses recyceln und 100 % des Wassers wiederzuverwenden. Alle Abfälle werden getrennt. Eine innovative und hocheffiziente Kraft-Wärme-Kopplungsanlage sowie das demnächst fertiggestellte, große Photovoltaikfeld tragen zur Energieeinsparung bei. Kontinuierliche Maßnahmen zur Effizienzsteigerung und zur Senkung der Emissionen, wie etwa unsere Innovationen in der Logistik, reduzieren die Umweltauswirkung unseres Produktionswerks immer weiter. Und auch unser Produkt selbst kann als zirkulär definiert werden: Das Feinsteinzeug von Caesar ist extrem langlebig, und am Ende seines Lebenszyklus kann es für neue Verwendungen recycelt werden.

Модель экономики замкнутого цикла является ориентиром для нашей работы. Наши производственные процессы направлены на защиту окружающей среды, минимизацию потребления сырья и природных ресурсов. Мы можем обеспечить переработку 100% сырых и приготовленных отходов, возвращая их в производство; мы повторно используем 100% воды и осуществляем отдельный сбор всех отходов. Инновационная высокоэффективная когенерационная установка и большой массив фотоэлектрических батарей, который вскоре будет построен, способствуют общей экономии энергии. Непрерывная работа по повышению эффективности и снижению выбросов, а также инновации в логистике постоянно минимизируют воздействие нашего промышленного производства на окружающую среду. Наш продукт сам по себе квалифицируется как циркулярный: керамогранит Caesar чрезвычайно долговечен, а по окончании срока службы он может быть переработан для нового использования.

100% riciclo acqua

100% of recycled water

100% riciclo scarti ceramici

100% of recycled ceramic rejects

500t di risparmio annuo di CO₂

500t di risparmio annuo di CO₂

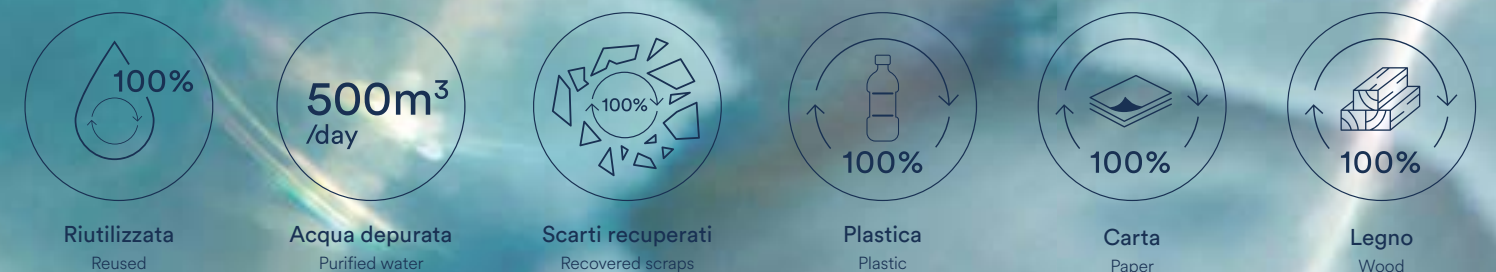

Photo by Alecio Ferrari "The instant of change" Styling: Studio Fluid

Un impegno sempre certificato

An always-certified commitment · Un engagement toujours certifié
Zertifiziertes Engagement · Всегда подтвержденное обязательство

Sappiamo che le parole hanno valore solo se confermate dai fatti. Per questo, tutti i nostri prodotti e processi rispondono alle più avanzate normative di sicurezza e tutela ambientale, attestate da enti certificatori indipendenti. A livello di prodotto, la recentissima ISO 17889-1 è il primo standard a trattare gli aspetti di sostenibilità delle piastrelle in ceramica; MSDS e DECLARE testimoniano che il prodotto è composto da sostanze inoffensive e attestano la sua riciclabilità. EPD e PEF calcolano l'impatto ambientale dei prodotti lungo il loro ciclo di vita. Anche il processo produttivo è certificato: ISO 9001 riconosce la continua ottimizzazione delle nostre pratiche industriali; ISO 14001 che abbiamo ottenuto per primi nel 1998- testimonia un impegno quotidiano nel perseguire processi a minimo impatto ambientale; ISO 45001 comprova la qualità dei nostri ambienti lavorativi. Il quadro è completato dai rating di edificio: LEED e WELL attestano il livello di sostenibilità e quello di salubrità di un edificio: le certificazioni in possesso di Caesar dimostrano che i nostri prodotti possono avere impatti positivi sul rating.

We know that words only take on meaning when backed by facts. For this reason, all our products and processes meet the most advanced safety and environmental protection standards, certified by independent certification bodies. At product level, the very recent ISO 17889-1 is the first standard to address the sustainability aspects of ceramic tiles; MSDS and DECLARE testify that the product is composed of harmless substances and attest to its recyclability. EPDs and PEFs calculate the environmental impact of products throughout their life cycle. The production process is certified as well: ISO 9001 recognises the continuous optimisation of our industrial practices; ISO 14001- which we obtained first in 1998- testifies to a daily commitment to pursuing processes with minimal environmental impact; ISO 45001 proves the quality of our working environments. The picture is completed by building ratings: LEED and WELL certify the level of sustainability and healthiness of a building: the certifications held by Caesar show that our products can have a positive impact on the rating.

Nous savons que les mots n'ont de valeur que s'ils sont confirmés par des faits. Pour cela, tous nos produits et processus respectent les normes de sécurité et de protection de l'environnement les plus strictes, comme le montrent les certifications accordées par des organismes indépendants. Concernant le produit, la toute récente norme ISO 17889-1 est la première à traiter des aspects de durabilité des carreaux de céramique; MSDS et DECLARE attestent que le produit est composé de substances inoffensives et certifient leur recyclabilité. EPD et PEF calculent l'impact environnemental des produits tout au long de leur cycle de vie. Notre processus de production est également certifié : ISO 9001 reconnaît l'optimisation continue de nos pratiques industrielles; ISO 14001, que nous avons été les premiers à obtenir en 1998, témoigne de notre engagement quotidien dans la recherche de processus à faible impact environnemental; ISO 45001 prouve la qualité de nos lieux de travail. Ce cadre est complété par les notations des bâtiments : LEED et WELL attestent le niveau de durabilité et de salubrité d'un bâtiment : les certifications obtenues par Caesar prouvent que nos produits peuvent avoir des impacts positifs sur la notation.

Es ist uns bewusst, dass ein Wort nur dann etwas wert ist, wenn ihm auch Fakten folgen. Deswegen erfüllen unsere Produkte ausnahmslos die anspruchsvollsten Richtlinien in Sachen Sicherheit und Umweltschutz, und sie sind von unabhängigen Prüfstellen entsprechend zertifiziert. Was die Produkte betrifft, ist die neue ISO 17889-1 die erste, die Nachhaltigkeit von Keramikfliesen betreffende Norm. Mit dem MSDS und DECLARE wird bezeugt, dass unsere Produkte aus unschädlichen Substanzen bestehen und recycelbar sind. EPD und PEF berechnen die Umweltauswirkung der Produkte über ihren gesamten Lebenszyklus. Auch der Produktionsprozess ist zertifiziert: Die kontinuierliche Optimierung unserer Produktionsverfahren ist nach ISO 9001 nachgewiesen; die Zertifizierung nach ISO 14001, die wir 1998 als erste erhalten haben, bescheinigt unser tägliches Engagement zugunsten von möglichst umweltschonenden Prozessen, und mit jener nach ISO 45001 wurde die Qualität unserer Arbeitsumgebung nachgewiesen. Komplettiert werden unsere Zertifizierungen durch das Gebäude-Rating: LEED und WELL bewerten, wie nachhaltig und gesund ein Gebäude ist: Die Zertifizierungen von Caesar beweisen, dass unsere Produkte einen positiven Einfluss auf die Einstufung haben können.

Мы знаем, что слова имеют ценность только в том случае, если они подкреплены фактами. По этой причине все наши продукты и процессы соответствуют самым современным стандартам безопасности и охраны окружающей среды, подтвержденным независимыми органами сертификации. Что касается продукции, недавно принятый стандарт ISO 17889-1 является первым стандартом, рассматривающим аспекты устойчивости керамической плитки; MSDS и DECLARE подтверждают, что продукт не содержит вредных веществ, и свидетельствуют о возможности его вторичной переработки. EPD и PEF рассчитывают воздействие продукции на окружающую среду на протяжении всего ее жизненного цикла. Сертифицирован также и процесс производства: ISO 9001 признает постоянную оптимизацию нашей производственной практики; ISO 14001, который мы впервые получили в 1998 году, свидетельствует о ежедневной приверженности процессам с минимальным воздействием на окружающую среду; ISO 45001 подтверждает качество нашей рабочей среды. Картины дополняют рейтинги зданий: LEED и WELL свидетельствуют об уровне устойчивости и экологической чистоте здания: сертификаты, полученные компанией Caesar, подтверждают, что наша продукция может оказать положительное влияние на этот рейтинг.

Certificazioni di prodotto · Product certifications



Declare.

MSDS

Certificazioni di processo · Process Certifications



GPP

Rating di edificio · Building rating

WELL

LEED

Altre certificazioni nazionali e internazionali

Negli anni abbiamo conseguito altre importanti certificazioni internazionali che ci consentono di accedere ai principali mercati mondiali, tra questi: **UPEC per la Francia e CCC per la Cina.**

Other national and international certifications

Over the years, we have achieved other important international certifications that give us access to major world markets, including: **UPEC for France and CCC for China.**



Impegno quotidiano per le persone e la comunità

Daily commitment to people and the community · Engagement quotidien pour les personnes et la communauté · Tägliches Engagement für Mensch und Gemeinschaft · Ежедневная забота о людях и обществе

Ci impegniamo responsabilmente per garantire la massima sicurezza e il benessere dei lavoratori. I nostri ambienti produttivi e commerciali sono sicuri, salubri e confortevoli: lo confermano le certificazioni internazionali ISO 9001 e ISO 45001. Sosteniamo la crescita professionale e motivazionale dei dipendenti, con continue attività formative e siamo aperti a nuovi modelli organizzativi come lo smart working.

Il concetto di benessere riguarda anche gli ambienti di vita di chi sceglie i nostri prodotti, che consentono di realizzare spazi salubri e sicuri. La governance di Caesar è da sempre indirizzata a un inserimento virtuoso nella comunità locale, che sostiene con iniziative di carattere sociale e culturale volte a favorirne la crescita e lo sviluppo.

We are responsibly committed to ensuring maximum safety and the well-being of workers. Our production and sales environments are safe, healthy and comfortable: this is confirmed by international certifications ISO 9001 and ISO 45001. We support the professional and motivational growth of our employees with continuous training activities and are open to new organisational models such as WFO.

The concept of well-being also applies to the living environments of those who choose our products, which allow for healthy and safe spaces. Caesar's governance has always aimed towards virtuous inclusion in the local community, which it supports with social and cultural initiatives aimed at fostering its growth and development.

Nous nous engageons, en toute responsabilité, pour garantir une sécurité maximale et le bien-être des travailleurs. Nos sites de production et commerciaux sont sûrs, sains et confortables : les certifications internationales ISO 9001 et ISO 45001 le confirment. Nous soutenons la croissance professionnelle et favorisons la motivation des employés, avec des activités de formation continues, et sommes ouverts à de nouveaux modèles d'organisation comme le télétravail.

Le concept de bien-être concerne également les lieux de vie des personnes qui choisissent nos produits, qui permettent de réaliser des espaces sains et sûrs. Depuis toujours, la gouvernance de Caesar s'est attachée à s'intégrer de manière vertueuse dans la communauté locale, qu'elle soutient avec des initiatives à caractère social et culturel visant à favoriser sa croissance et son développement.

Wir sind dafür verantwortlich, maximale Sicherheit und Wohlbefinden der Arbeitnehmer zu garantieren. Unsere Produktions- und Verwaltungsbereiche sind sicher, gesund und angenehm:

Das bestätigen die internationalen Zertifizierungen ISO 9001 und ISO 45001. Wir fördern das professionelle Wachstum und motivieren unsere Mitarbeiter durch regelmäßige Fortbildungsmaßnahmen, und sind offen für neue Organisationsmodelle wie das Smart Working.

Das Konzept des Wohlbefindens betrifft auch die Lebensräume jener, die unsere Produkte wählen, um gesunde und sichere Räume zu gestalten. Seit jeher bemüht sich die Unternehmensleitung um eine positive Integration in die lokale Gemeinschaft und unterstützt diese durch soziale und kulturelle Initiativen in ihrer Entwicklung.

Мы ответственно относимся к обеспечению максимальной безопасности и благополучия работников. Наша производственная и торговая среда безопасна, благоприятна и комфортна: это подтверждено международными сертификатами ISO 9001 и ISO 45001. Мы поддерживаем профессиональный рост и мотивацию наших сотрудников посредством постоянного обучения и открыты для новых организационных моделей, таких как "удаленная работа".

Концепция благополучия распространяется и на жилые пространства тех, кто выбирает нашу продукцию, которая позволяет создать здоровое и безопасное пространство. Руководство компании Caesar всегда было направлено на добродетельное включение в жизнь местного сообщества, которое оно поддерживает социальными и культурными инициативами, направленными на его рост и развитие.



I nostri spazi per le tue idee

Our spaces for your ideas · Nos espaces pour vos idées
Unsere Räume für Ihre Ideen · Наши пространства для Ваших идей

Luoghi aperti e in ascolto, per accogliere le tue ispirazioni. Londra, Parigi e Milano: nelle principali capitali del design, oltre che nelle nostre sedi di Fiorano, in Italia, e Nashville, in America, abbiamo aperto moderni e funzionali spazi di incontro, rivolti in particolar modo ai progettisti e agli architetti. E, più in generale, a chiunque sia in cerca di idee e consigli per dare personalità ai propri spazi. Luoghi aperti e accoglienti, nei quali siamo presenti pronti all'ascolto e al dialogo per presentare le nostre ultime novità e, soprattutto, fornire spunti di arredo e progettazione per dare concretezza alle tue ispirazioni.

Open settings where we listen, to capture your inspirations. London, Paris and Milan: in the major design capitals, as well as in our headquarters in Fiorano, in Italy, and in Nashville, USA, we have opened modern and functional meeting places, aimed particularly at designers and architects. And, more generally, at anyone in search of ideas and advice to add personality to their space. Open, welcoming places, where we are ready and willing to listen and liaise, to present our latest products and, above all, to provide tips on furniture and design to allow your inspirations to take shape.

Des lieux ouverts et d'écoute, pour accueillir vos inspirations. Londres, Paris et Milan : dans les principales capitales du design, en plus de nos sièges de Fiorano en Italie et de Nashville aux États-Unis, nous avons ouvert des espaces de rencontre modernes et fonctionnels, principalement destinés aux concepteurs et aux architectes. Et, plus généralement, à tous ceux qui recherchent des idées et des conseils pour apporter de la personnalité à leurs espaces. Des lieux ouverts et accueillants, dans lesquels nous sommes présents, prêts à l'écoute et au dialogue pour vous présenter nos dernières nouveautés et, surtout, vous fournir des conseils de décoration et de conception pour concrétiser vos inspirations.

Orte des Austauschs, an denen Ihre Ideen und Inspirationen auf offene Ohren stoßen. London, Paris und Mailand: In den wichtigsten Design-Städten sowie in unseren Firmenzentralen in Fiorano, Italien und Nashville, USA haben wir moderne und funktionelle Begegnungsorte eröffnet, die sich in besonderem Maße an Planer und Architekten wenden. Und natürlich an alle, die auf der Suche nach Ideen und Tipps sind, um ihre Räume mit Persönlichkeit zu füllen. Offene und einladende Orte, an denen wir Ihnen zuhören und Ihnen unsere Neuheiten zeigen. Hier bieten wir Ihnen Anregungen sowie planerische Unterstützung, damit Ihre Ideen Form annehmen können.

Открытые пространства для вашего вдохновения. Лондон, Париж и Милан: в главных столицах дизайна, а также в наших офисах во Фьорано, Италия, и Нашвилле, США, мы открыли современные и функциональные выставочные залы, предназначенные для дизайнеров и архитекторов. Выставочные залы окажутся полезными и для всех тех, кто находится в поиске хороших идей и рекомендаций по приданию индивидуальности своим проектам. Выставочные залы – это открытые и гостеприимные пространства, где мы готовы выслушать вас и пообщаться, чтобы представить наши последние новинки и, в первую очередь, предложить интересные идеи для создания интерьеров и проектов, которые позволят конкретизировать ваше вдохновение.



Paris Urban Lab



Milano Urban Lab



London Urban Lab



Headquarter - Spezzano, Italy



Caesar Ceramics Usa

Al tuo fianco anche online

By your side also on-line · À vos côtés, même en ligne
Immer an Ihrer Seite. Auch online · Всегда рядом с Вами, в том числе и онлайн

I nostri servizi e strumenti digitali sono pensati per fornire un supporto continuo e altamente qualificato, attraverso consulenze progettuali e condivisione di risorse e competenze. Con il team dedicato Caesar Service, in una rete selezionata di punti vendita, assistiamo privati e professionisti nello sviluppo dei progetti di ristrutturazione e interior design. Abbiamo inoltre sviluppato l'app Caesar Community per semplificare l'accesso di rivenditori e designer a risorse e contenuti utili. Sui nostri principali strumenti promozionali, è sempre disponibile un QR code che indirizza a tutte le risorse e i servizi digitali a vostra disposizione. Tra questi, anche Virtual Room, accessibile all'indirizzo www.caesar.it/virtual-room: una app immersiva per creare la vostra combinazione preferita, bilanciando più superfici nella loro varietà di look e colori. Per trovare il dress architettonico ideale, è possibile scegliere tra le numerose proposte suggerite dai nostri designer, o caricare una foto dei vostri spazi e sperimentare infinite combinazioni di stile.

Our digital tools and services are devised to provide continued and highly-qualified support, in the form of design consultancy and the sharing of resources and skills. With the dedicated Caesar Service team, in a selected network of outlets, we assist private and professional customers in the development of renovation and interior design projects. We also developed the Caesar Community app to simplify retailers' and designers' access to useful resources and content. On our main promotional tools, a QR code is always available that addresses all digital resources and services available to you. These include Virtual Room, accessible at www.caesar.it/virtual-room: an immersive app to create your favourite combination, balancing multiple surfaces in their variety of looks and colours. To find the ideal architectural dress, you can choose from the many proposals suggested by our designers, or upload a photo of your space and experiment with endless combinations of style.

Nos services et outils numériques sont pensés pour fournir aux professionnels un support constant et hautement qualifié, via des conseils pour la conception et le partage de ressources et de compétences. Grâce à l'équipe dédiée Caesar Service, dans un réseau sélectionné de points de vente, nous aidons les professionnels et les particuliers dans le développement de projets de reconstruction et de design d'intérieur. Nous avons également développé l'appli Caesar Community pour simplifier l'accès à des ressources et contenus utiles pour les revendeurs et designers. Un QR code est toujours présent sur nos principaux outils promotionnels pour vous informer de toutes les ressources et des services numériques à votre disposition. Parmi ces services, citons Virtual Room, accessible à l'adresse www.caesar.it/virtual-room: une appli immersive pour créer votre assortiment préféré, en associant plusieurs surfaces dans leur variété d'aspects et de couleurs. Pour trouver le 'dress code' architectural idéal, il est possible de choisir entre les nombreuses propositions suggérées par nos designers ou télécharger une photo de vos espaces et tester d'innombrables combinaisons de style.

Unser Service und unsere digitalen Instrumente bieten jederzeit hochqualifizierte Unterstützung durch Projektberatung und Teilung von Ressourcen und Kompetenzen. Mit den Experten des Caesar Service-Teams unterstützen wir über ein ausgewähltes Händlernetz Privatkunden und Profis bei der Ausarbeitung ihrer Renovierungs- und Innendesignprojekte. Die App Caesar Community vereinfacht zudem Händlern und Designern den Zugriff auf nützliche Ressourcen und Inhalte. In unseren wichtigsten Werbeinitiativen finden Sie stets einen QR-Code, der schnell zu allen verfügbaren Ressourcen und digitalen Service-Leistungen führt. Darunter auch der unter der Adresse www.caesar.it/virtual-room zugängliche Virtual Room: Eine immersive App zur Kreierung Ihrer Lieblingskombination aus den verschiedenen Belägen mit ihrer ganzen Vielfalt aus Farben und Looks, aus denen Sie den perfekten Mix zusammenstellen können. Um das ideale architektonische Kleid zu finden, haben Sie die Wahl unter den zahlreichen Vorschlägen unserer Designer; Sie können aber auch ein Foto Ihrer Räumlichkeiten hochladen und mit unendlichen Stilkombinationen spielen.

Наши услуги и цифровые инструменты призваны предоставлять постоянную и высококвалифицированную поддержку посредством консультирования по проектам и обмена ресурсами и опытом. С помощью специальной команды Caesar Service, в избранной сети торговых точек, мы помогаем частным и профессиональным клиентам в разработке проектов реконструкции и дизайна интерьера. Мы также разработали приложение Caesar Community для упрощения доступа продавцов и дизайнеров к полезным ресурсам и контенту. На наших основных рекламных инструментах всегда доступен QR-код, который указывает на все доступные вам цифровые ресурсы и услуги. Среди них - Virtual Room (Виртуальный салон), доступный на сайте www.caesar.it/virtual-room: иммерсивное приложение для создания вашей любимой комбинации, с возможностью выбора между несколькими поверхностями, разнообразными по их отделкам и цветам. Чтобы найти идеальное архитектурное обрамление, Вы можете выбрать из множества предложений, представленных нашими дизайнерами, или загрузить фотографию Вашего помещения и экспериментировать с бесконечными комбинациями стиля.



Info
Resources
Tools

Collezioni

Collections · Collections
Kollektionen · Коллекциикол

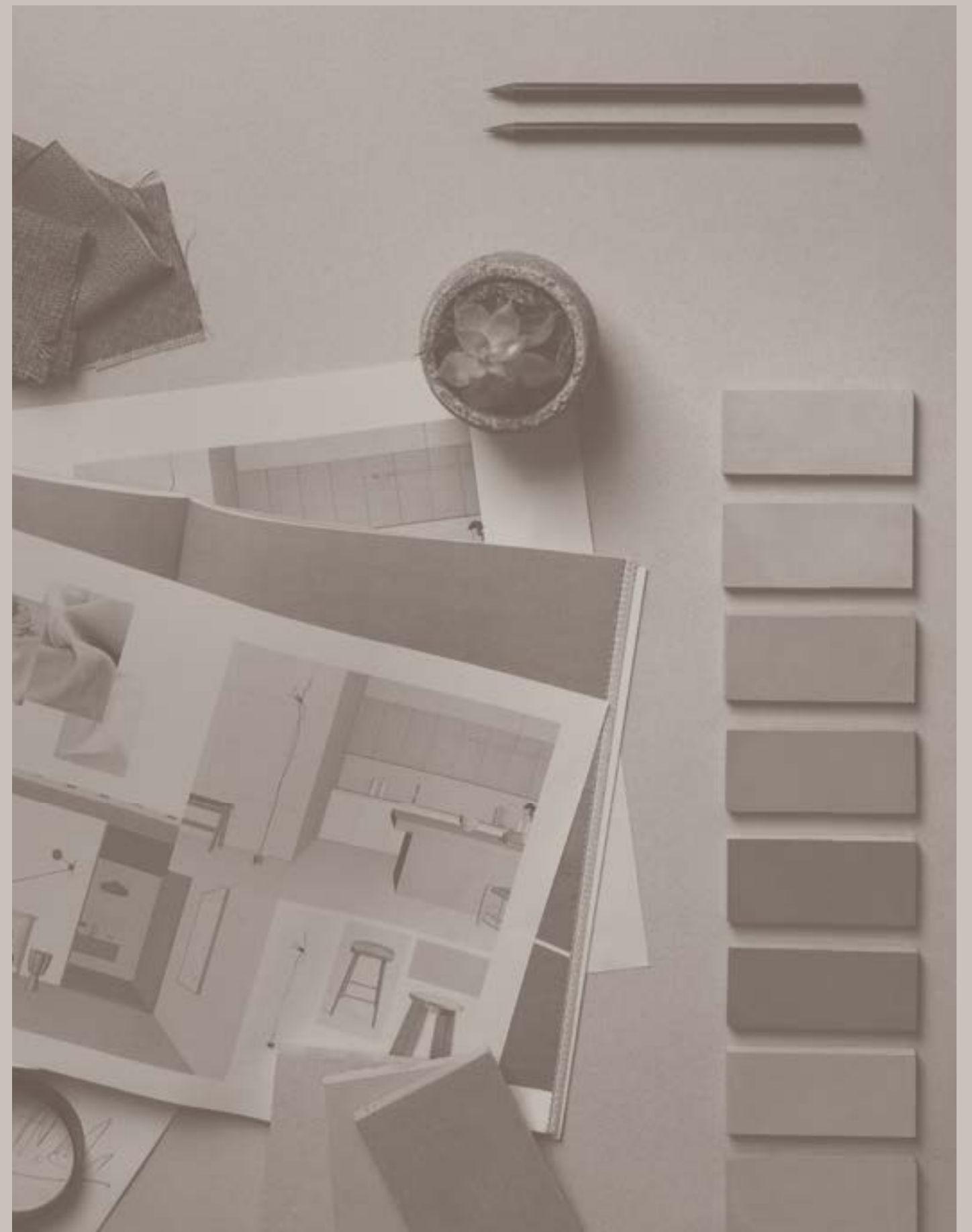

Metal Look

Dal fascino cangiante dei metalli e dagli ultimi trend, svariate suggestioni per caratterizzare i tuoi progetti con un'anima seducente e sorprendente.

Featuring the iridescent charm of metals and the latest design trends, various suggestions to distinguish your projects with a seductive and surprising soul.

Avec le charme changeant des métaux et les dernières tendances, plusieurs suggestions permettent de caractériser vos projets avec une âme séduisante et surprenante.

Von faszinierend schillernden Metallen und den jüngsten Trends stammen verschiedenste Ideen, die Ihren Projekten ein attraktives und überraschendes Gepräge geben.

Многочисленные предложения переливчатых металлических поверхностей и самых свежих трендов подарят вашим проектам особую привлекательность и оригинальность.



Metal Look

The collections

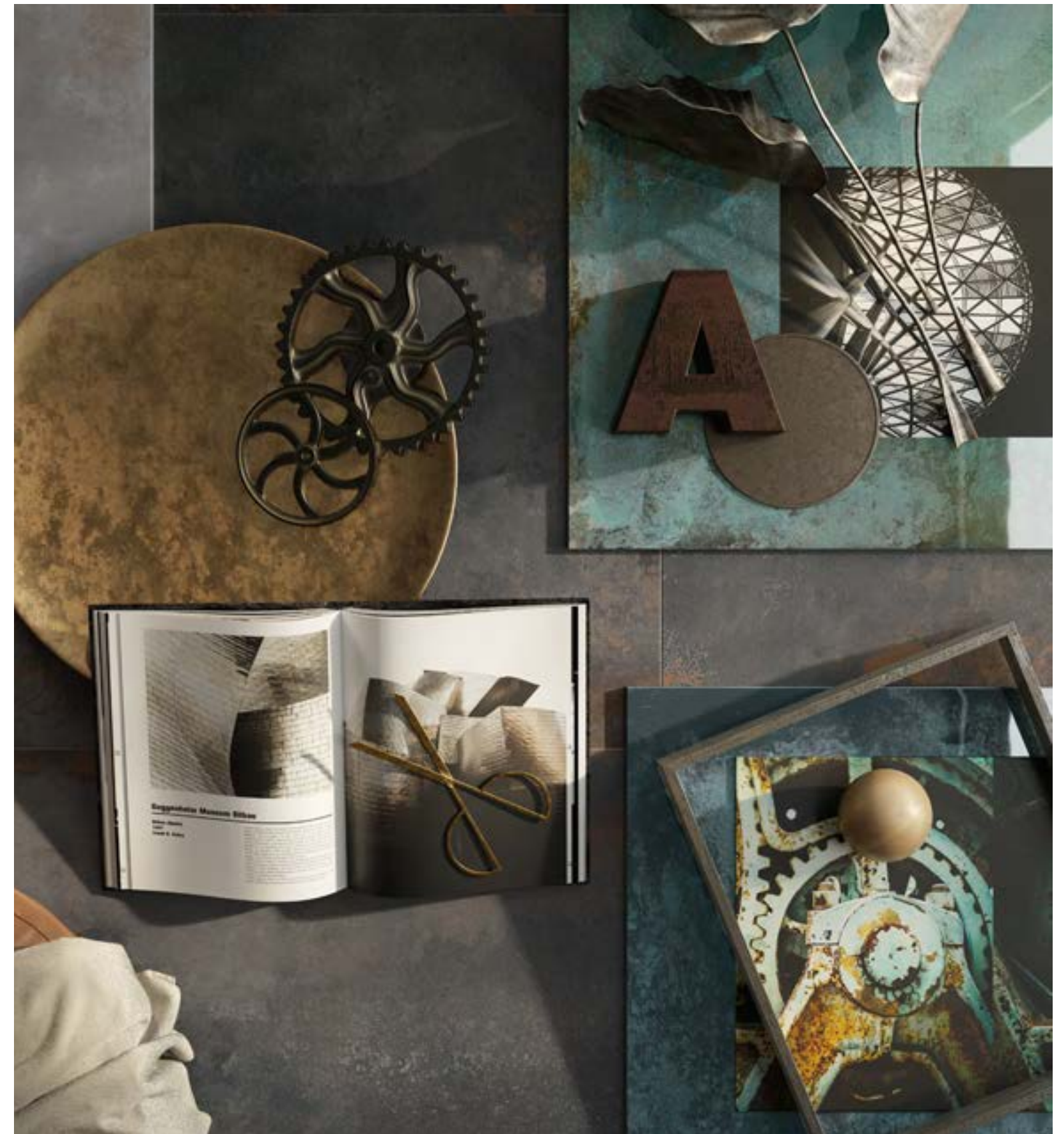
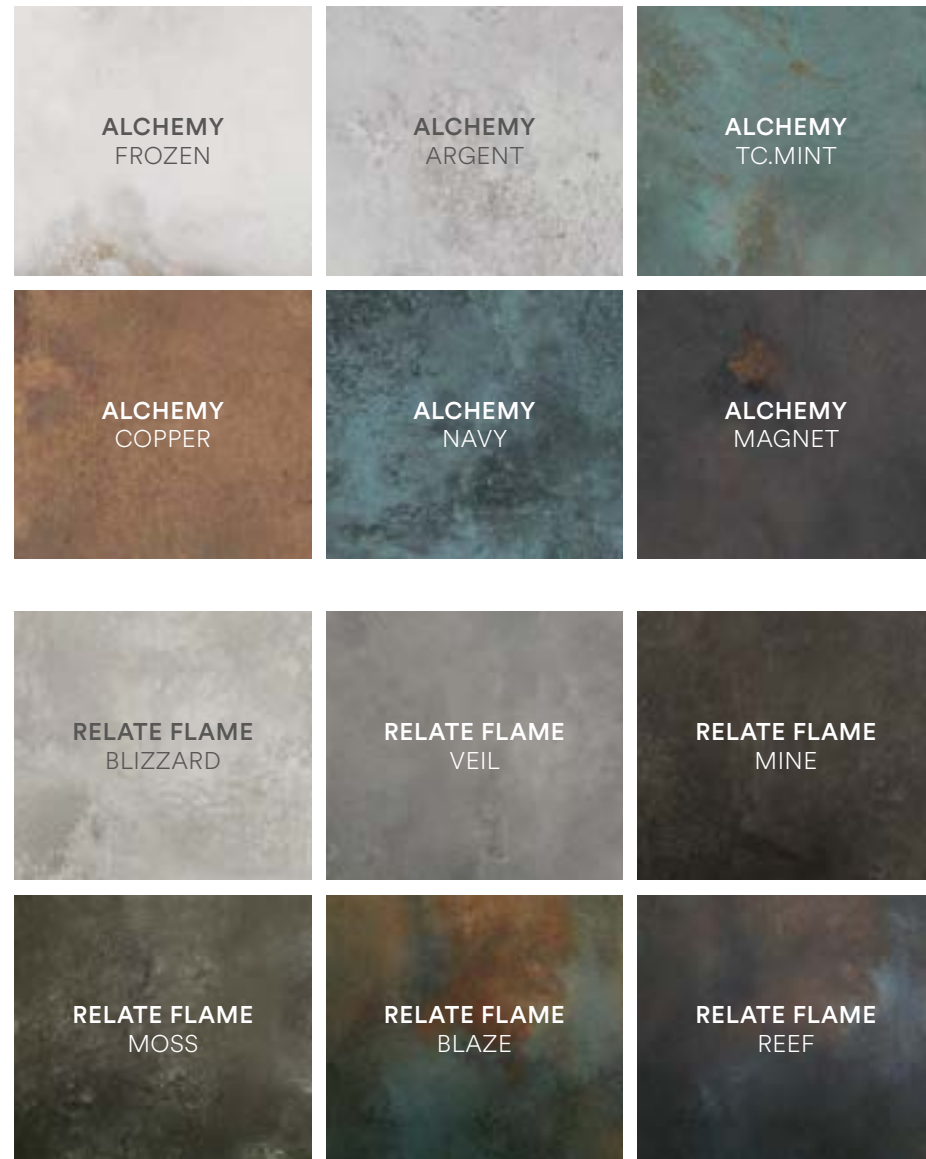

Alchemy

At the cutting edge of style



Alchemy accende gli spazi di vita con i suoi colori intensi, le sue variazioni cromatiche decise e ricche di sfumature. Accattivante e contemporanea, Alchemy esplora la bellezza del look metallo, seguendo i percorsi imprevedibili e i sorprendenti cromatismi che l'ossidazione crea sulla sua superficie.

Alchemy lights up living spaces with its intense colours, its decisive chromatic variations, rich in shades. Captivating and contemporary, Alchemy explores the beauty of metal, following the unpredictable paths and surprising colours that oxidation creates on its surface.

Alchemy éclaire les espaces de vie avec ses couleurs intenses, ses variations chromatiques prononcées et riches en nuances. Séduisante et contemporaine, Alchemy explore la beauté de l'effet métal, en suivant des parcours imprévisibles, grâce aux surprenants chromatismes que l'oxydation donne aux surfaces.

Alchemy belebt die Lebensräume mit seinen intensiven Farben und seinen markanten, nuancenreichen Farbübergängen. Das attraktive und aktuelle Alchemy sondiert die Schönheit des Metalls unter Erkundung all jener unvorhersehbaren und überraschenden Farbeffekte, die die Oxidierung an seiner Oberfläche erzeugt.

Коллекция Alchemy освещает жилые интерьеры своими интенсивными цветами и хроматическими вариациями, с присущими им решительным характером и разнообразием оттенков. Завораживающая и современная, коллекция Alchemy выражает всю красоту металла, повторяя непредсказуемые линии и завораживающую яркость цветов, которые окисление создает на его поверхности.



Info
Resources
Tools



Floor: NAVY 60x120 MATT RT
Wall: NAVY 60x120 LUCIDATO RT, ARGENT 60x120, 60x60 MATT RT

Colori - Formati

Colors - Sizes

160x320 . 120x278 6 mm MATT RT
 120x120 . 60x120 9 mm LUCIDATO RT
 120x120 . 60x120 . 80x80 . 40x80 . 60x60 . 30x60 . 30x30 9 mm MATT RT
 60x60 20 mm AEXTRA20 RT R11 C

FROZEN



TC.MINT



ARGENT



NAVY



MAGNET



COPPER

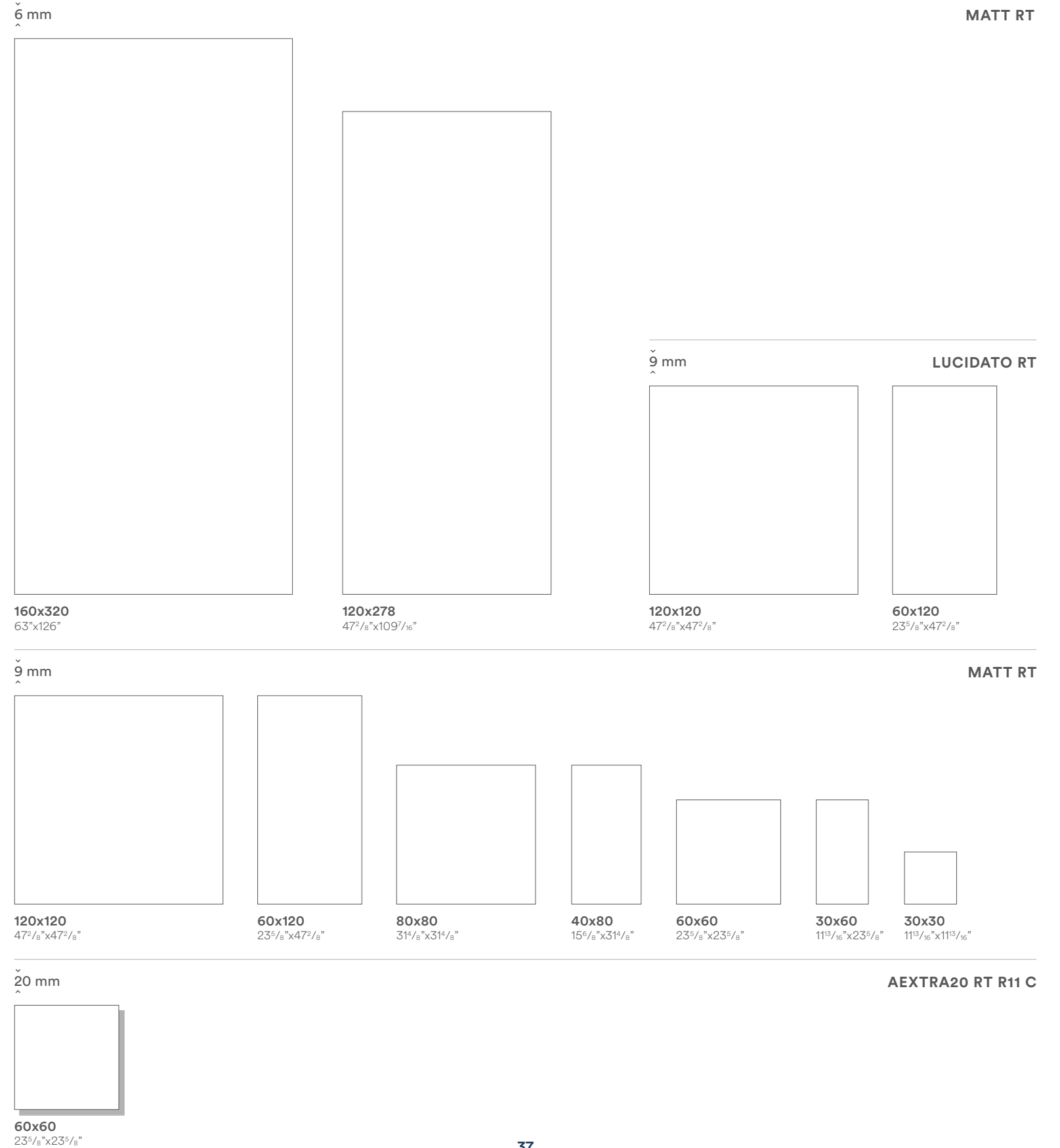











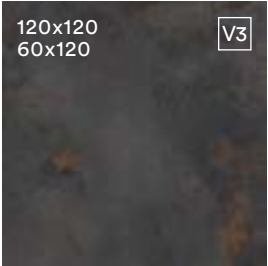





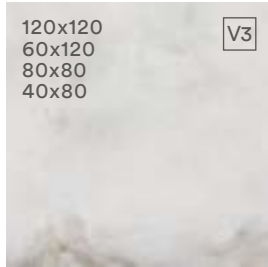

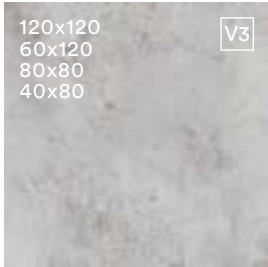

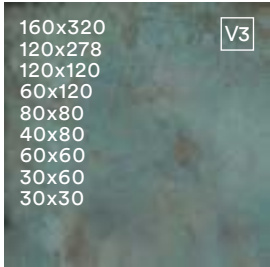

Alchemy

METAL LOOK

La gamma

The range

| | FROZEN | ARGENT | MAGNET | TC.MINT  | NAVY | COPPER |
|-------------------|-------------------------------------------------------------------------------------------------------------------------------------------------------------------------------------------------------------|-------------------------------------------------------------------------------------------------------------------------------------------------------------------------------------------------------------|----------------------------------------------------------------------------------------------------------------------------------------------------------------------------------------------------------------|------------------------------------------------------------------------------------------------------------------------------------------------------------------------------------------------------------------------------------------------------------------|----------------------------------------------------------------------------------------------------------------------------------------------------------------------------------------------------------------------------|----------------------------------------------------------------------------------------------------------------------------------------------------------------------------------------------------------------------------|
| LUCIDATO RT |  120x120 60x120  | |  120x120 60x120  |  120x120 60x120  |  120x120 60x120  | |
| MATT RT |  120x120 60x120 80x80 40x80  |  120x120 60x120 80x80 40x80  |  120x120 60x120 80x80 40x80  |  160x320 120x278 120x120 60x120 80x80 40x80 60x60 30x60 30x30  |  120x278 120x120 60x120 80x80 40x80  |  120x278 120x120 60x120 80x80 40x80  |
| AEXTRA20 RT R11 C | | | |  60x60  | | |

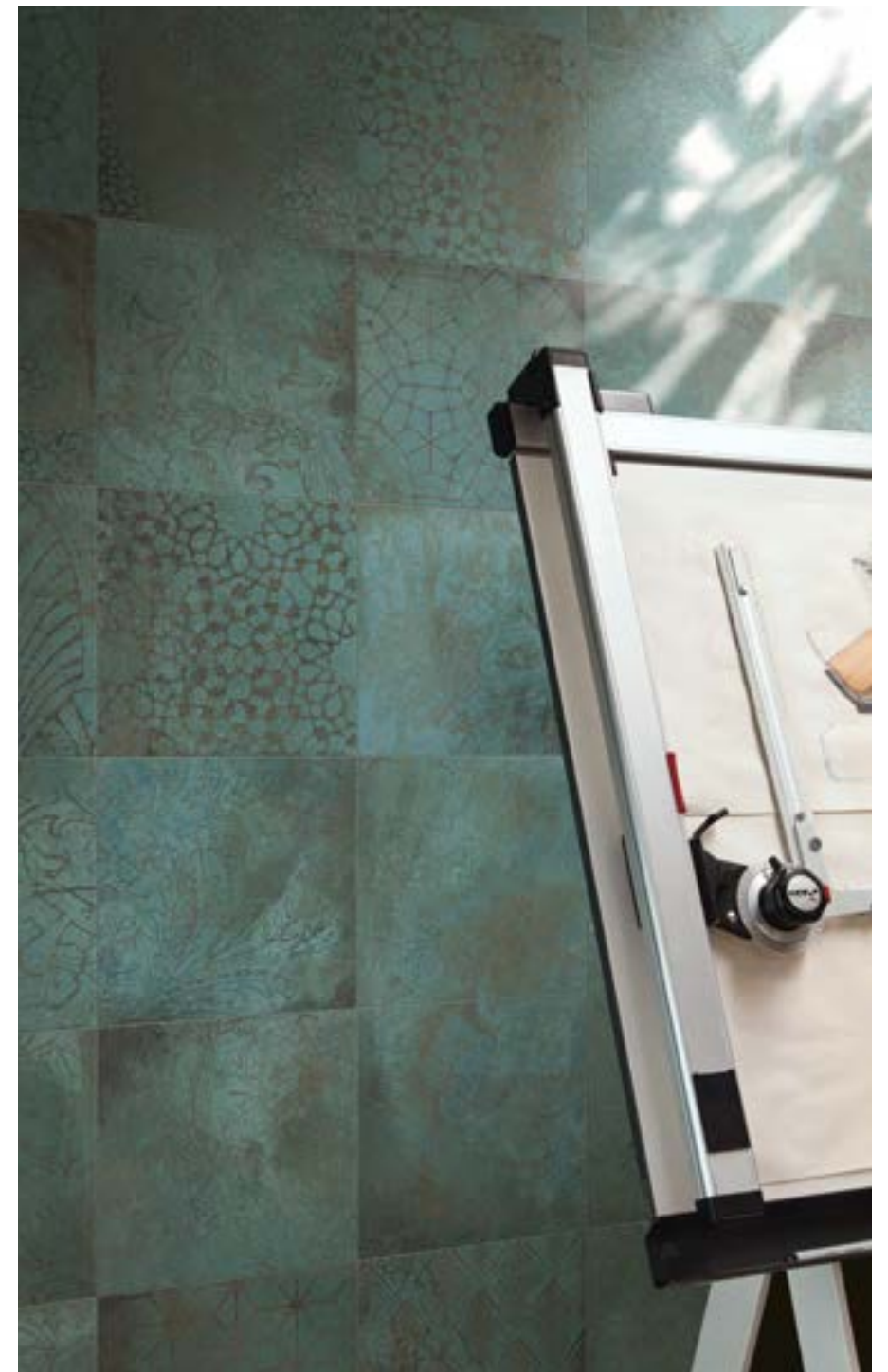

RT Rettificato, quadrato, monocalibro. - Rectified, squared, one caliber. - Rectifié, mis d'équerre et monocalibre. - Rektifiziert, rechtwinkelig und Ein kaliber. - Ректифицированный, одного калибра.

Decori

Decors

COMPOSIZIONE N 30x30 cm . 11¹³/₁₆"x11¹³/₁₆" MATT



FROZEN



ARGENT



MAGNET



TC.MINT



NAVY



COPPER

COMPOSIZIONE N BRASS 30x30 cm . 11¹³/₁₆"x11¹³/₁₆" MATT



FROZEN



ARGENT



MAGNET



TC.MINT



NAVY



COPPER

COMPOSIZIONE N GLASS 30x30 cm . 11¹³/₁₆"x11¹³/₁₆" MATT



FROZEN



ARGENT



MAGNET



TC.MINT



NAVY



COPPER

3D HEXAGONS 28x34 cm . 11"x13³/₈" MATT



FROZEN



ARGENT



MAGNET



TC.MINT



NAVY



COPPER

Composizione N è anche disponibile nelle versioni con bacchetta in ottone (Composizione N Brass) e effetto acciaio con finitura a specchio (Composizione N Glass).
Composizione N is also available in versions with brass rods (Composizione N Brass) and rods with mirror finish steel effect (Composizione N Glass).
Composizione N est également disponible dans les versions avec baguette en laiton (Composizione N Brass) et effet acier avec finition miroir (Composizione N Glass).
Composizione N ist auch in den Ausführungen mit Messingstäbchen (Composizione N Brass) sowie mit einer hochglanz Stahlloptik (Composizione N Glass) erhältlich.
Composizione N доступна в версии с полосой из латуни (Composizione N Brass) и эффектом стали с зеркальной отделкой (Composizione N Glass).

Alchemy

METAL LOOK

Decori

Decors

TC.MINT DECO 60x60 cm . 23⁵/₈"x23⁵/₈" MATT RT

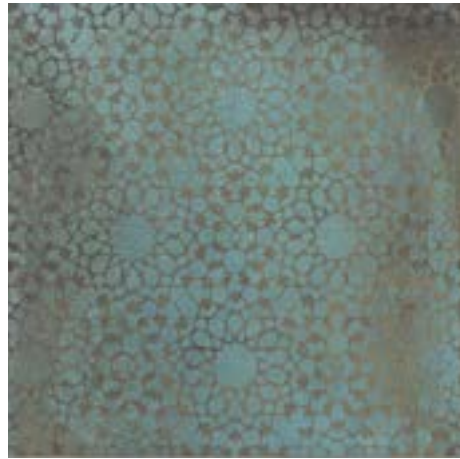

TC.MINT DECO 30x30 cm . 11¹³/₁₆"x11¹³/₁₆" MATT RT



COMPOSIZIONE A 30x30 cm . 11¹³/₁₆"x11¹³/₁₆" MATT



TC.MINT

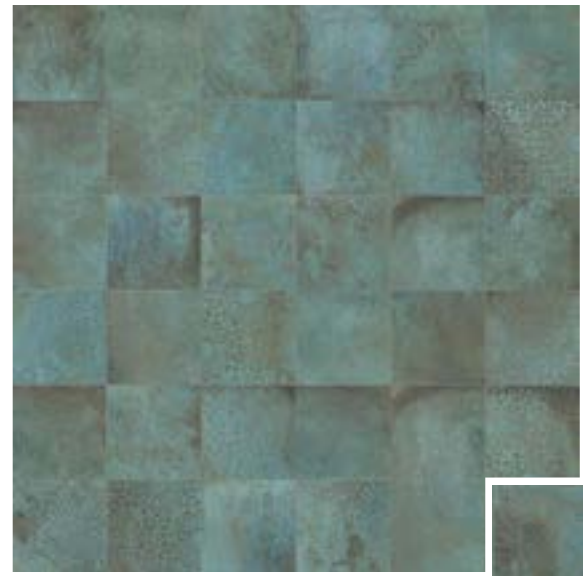
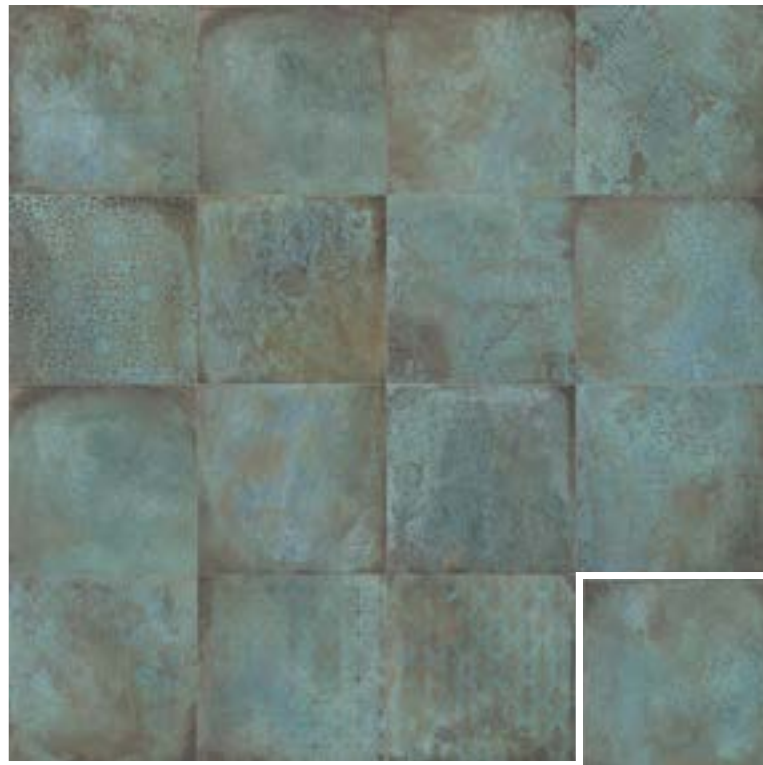

NAVY DECO 20x20 cm . 7⁷/₈"x7⁷/₈" MATT RT

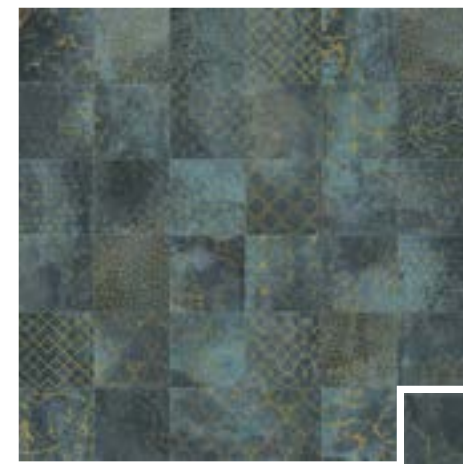

COPPER DECO 20x20 cm . 7⁷/₈"x7⁷/₈" MATT RT



RT Rettificato, quadrato, monocalibro. - Rectified, squared, one caliber. - Rectifié, mis d'équerre et monocalibre. - Rektifiziert, rechtwinkelig und Ein kaliber. - Ректифицированный, одного калибра.

CARATTERISTICHE TECNICHE

TILE PERFORMANCE DATA - NOTES TECHNIQUES - TECHNISCHE AUSKÜNFTE - ТЕХНИЧЕСКАЯ ХАРАКТЕРИСТИКА

Classificazione secondo EN ISO 14411 ISO 13006 annesso G gruppo Bla con Ev ≤0,5% - Classification in accordance with EN ISO 14411 ISO 13006 annex G standards Bla with Ev ≤ 0,5% - Classification selon EN ISO 14411 ISO 13006 annexe G groupe Bla avec Ev ≤0,5% - Klassifizierung gemäß EN ISO 14411 ISO 13006 anlage G Gruppe Bla mit Ev ≤0,5% - Классификация в соответствии с EN ISO 14411 ISO 13006, приложение G, стандарт Bla, где Ev ≤0,5%

| | 160x320 cm 63"x126" 6 mm MATT RT | 120x278 cm 47 1/8"x109 7/16" 6 mm MATT RT | 120x120 cm 47 1/8"x47 1/8" 9 mm MATT RT | 120x120 cm 47 1/8"x47 1/8" 9 mm LUCIDATO RT | 60x120 cm 23 5/8"x47 1/8" 9 mm MATT RT | 60x120 cm 23 5/8"x47 1/8" 9 mm LUCIDATO RT | 80x80 cm 31 1/8"x31 1/8" 9 mm MATT RT | 40x80 cm 15 7/8"x31 1/8" 9 mm MATT RT | 60x60 cm 23 5/8"x23 5/8" 9 mm MATT RT | 30x60 cm 11 7/8"x23 5/8" 9 mm MATT RT | 30x30 cm 11 7/8"x11 7/8" 9 mm MATT RT | 60x60 cm 23 5/8"x23 5/8" 20 mm RT R11 C |
|---------|-------------------------------------------|----------------------------------------------------|--------------------------------------------------|------------------------------------------------------|-------------------------------------------------|-----------------------------------------------------|------------------------------------------------|------------------------------------------------|------------------------------------------------|------------------------------------------------|------------------------------------------------|--------------------------------------------------|
| Frozen | | | ● | ● | ● | ● | ● | ● | | | | |
| Argent | | | ● | ● | ● | ● | ● | ● | | | | |
| Magnet | | | ● | ● | ● | ● | ● | ● | | | | |
| Tc.Mint | ● | ● | ● | ● | ● | ● | ● | ● | ● | ● | ● | ● |
| Navy | | ● | ● | ● | ● | ● | ● | ● | | | | |
| Copper | | ● | ● | ● | ● | ● | ● | ● | | | | |

| | 7,2x80 cm 2 7/8"x31 1/8" MATT | 7,2x60 cm 2 7/8"x23 5/8" MATT | 7,2x60 cm 2 7/8"x23 5/8" LUCIDATO | 33x120 cm 13"x47 1/8" MATT | 33x120 cm 13"x47 1/8" LUCIDATO | 33x60 cm 13"x23 5/8" MATT | 33x80 cm 13"x31 1/8" MATT | 33x33 cm 13"x13" MATT | 33x33 cm 13"x13" LUCIDATO |
|---------|-------------------------------------|-------------------------------------|-----------------------------------------|----------------------------------|--------------------------------------|---------------------------------|---------------------------------|-----------------------------|---------------------------------|
| Frozen | ● | | ● | ● | ● | | ● | ● | ● |
| Argent | ● | | | ● | ● | | ● | ● | ● |
| Magnet | ● | | | ● | ● | | ● | ● | ● |
| Tc.Mint | ● | ● | ● | ● | ● | ● | ● | ● | ● |
| Navy | ● | | ● | ● | ● | | ● | ● | ● |
| Copper | ● | | | ● | ● | | ● | ● | ● |

IMBALLI - PACKAGING - CONDITIONNEMENT - VERPACKUNGS-EINHEITEN - УПАКОВКА

| Formato - Size - Format - Формат | | Scatola - Box - Boîte - Karton - Коробка | | | Pallet - Palette - Палета | | |
|----------------------------------|-------------------|------------------------------------------|---------|--------|---------------------------|--------|----------|
| CM | INCHES | PZ | MQ | KG | SC | MQ | KG |
| 160x320 | 63"x126" | 1 | 5,12 | ~78,00 | 14 | 71,68 | ~1092,00 |
| 120x278 | 47 1/8"x109 7/16" | 1 | 3,3221 | ~49,56 | 18 | 59,79 | ~892,08 |
| 120x120 | 47 1/8"x47 1/8" | 2 | 2,85605 | ~62,00 | 20 | 57,121 | ~1240,00 |
| 60x120 | 23 5/8"x47 1/8" | 2 | 1,44 | ~30,40 | 35 | 50,40 | ~1064,00 |
| 80x80 | 31 1/8"x31 1/8" | 2 | 1,28 | ~27,36 | 48 | 61,44 | ~1313,28 |
| 40x80 | 15 7/8"x31 1/8" | 4 | 1,28 | ~24,90 | 28 | 35,84 | ~697,20 |
| 60x60 | 23 5/8"x23 5/8" | 4 | 1,44 | ~28,40 | 30 | 43,20 | ~852,00 |
| 30x60 | 11 7/8"x23 5/8" | 7 | 1,26 | ~26,32 | 40 | 50,40 | ~1052,80 |
| 30x30 | 11 7/8"x11 7/8" | 11 | 0,99 | ~22,00 | 48 | 47,52 | ~1056,00 |
| 60x60 A E X T R A 2 0 | 23 5/8"x23 5/8" | 2 | 0,72 | ~32,00 | 30 | 21,60 | ~960,00 |

RT Rettificato, squadrato, monocalibro. - Rectified, squared, one caliber. - Rectifié, mis d'equerre et monocalibre. - Rektifiziert, rechteckig und Ein kaliber. - Ректифицированный, одного калибра.

** Disponibile solo su richiesta. - Manufactured only upon special request. - Seulement sur demande. - Nur auf Anfrage. - Производится только по заказу.

Si raccomanda l'utilizzo di una fuga di 2/3 mm al fine di semplificare le operazioni di posa e ottimizzare la naturalezza del risultato finale. - We recommend you a 2/3 mm grout joint to simplify the laying and optimize the naturalness of the final result. - Un joint de 2/3 mm est conseillé afin de simplifier les opérations de pose et optimiser l'effet naturel du résultat final. - Es wird empfohlen mit einer Fuge von 2/3 mm zu arbeiten, um am Ende den Verlegevorgang zu vereinfachen und die bestmögliche Natürlichkeit der Arbeit zu erzielen. - Для облегчения операций укладки и повышения натуральности вида конечного результата рекомендуется выполнять шов шириной 2-3 мм.

Al fine di facilitare la manutenzione ordinaria si raccomanda di effettuare un lavaggio acido dopo 48 ore dalla stuccatura con un acido specifico per grès porcellanato. - In order to favour the ordinary maintenance procedures, it is recommended to carry out an acid wash of the surface after 48 hours from grout filling using an acid agent specific for porcelain stoneware tiles. - Afin de faciliter l'entretien ordinaire de votre carrelage, nous vous conseillons de le laver 48 heures après le colmatage des joints, avec un acide spécifique pour grès cérame. - Um die Instandhaltung zu erleichtern, empfiehlt es sich 48 Stunden nach der Stuckatur mit einer sauren Lösung speziell für Feinsteinzeug zu waschen. - Чтобы упростить уход за плиткой, спустя 48 часов после затирки швов рекомендуется выполнить обработку кислотным продуктом, пригодным для керамогранита.

| | CARATTERISTICA TECNICA TECHNICAL CHARACTERISTIC CARACTERISTIQUE TECHNIQUE TECHNISCHE DATEN ТЕХНИЧЕСКАЯ ХАРАКТЕРИСТИКА | METODO DI PROVA TESTS METHOD METHODE D'ESSAI TESTMETHODE МЕТОД ИСПЫТАНИЯ | VALORE * MEDIO "CAESAR" AVERAGE "CAESAR" VALUE * VALEUR * MOYEN "CAESAR" "CAESAR" DURCHSCHNITTSWERT * СРЕДНЕЕ ЗНАЧЕНИЕ "CAESAR" * | | VALORE * MEDIO "CAESAR" AVERAGE "CAESAR" VALUE A E X T R A 2 0 OPEN YOUR STYLE |
|--|-----------------------------------------------------------------------------------------------------------------------------------------------------------------------------------------------------------------------------------------------|--------------------------------------------------------------------------------------|-----------------------------------------------------------------------------------------------------------------------------------------------|-----------------------------------------------------------------------------------------------------------------------------------------------------------------------------------|-----------------------------------------------------------------------------------------------------------------------------------------------------------------------------------------------------------------------------------------------------------------------------------------|
| | | | Matt | Lucidato | |
| | Dimensione - Size Dimension - Abmessungen - Размер | ISO 10545-2 | Conforme - In accordance Conforme - Erfüllt - Соответствует | Conforme - In accordance Conforme - Erfüllt - Соответствует | Conforme - In accordance Conforme - Erfüllt - Соответствует |
| | Assorbimento d'acqua* - Water absorption* Absorption d'eau* - Wasseraufnahme* - % Поглощения воды* | ISO 10545-3 | ≤ 0,1% | ≤ 0,1% | ≤ 0,1% |
| | Resistenza alla flessione* - Bending strength* Résistance à la flexion* - Biegezugfestigkeit* - Упругость* | ISO 10545-4 | Conforme - In accordance Conforme - Erfüllt - Соответствует | Conforme - In accordance Conforme - Erfüllt - Соответствует | Non applicabile a piastrelle con una forza di rottura Not applicable to tiles with a breaking strength N'est pas applicable aux carreaux avec une charge de rupture Nicht anwendbar bei Fliesen mit einer Bruchlast Не применяется в отношении плиток с прочностью на изрыв |
| | Sforzo di rottura (S) - Breaking strength Charge de rupture - Bruchlast - Разрушающее усилие | ISO 10545-4 | Sps ≥ 7,5 mm S ≥ 1300 N | Sps ≥ 7,5 mm S ≥ 1300 N | > 10.000 N |
| | Resistenza all'urto - Impact resistance Résistance au choc - Schlagfestigkeit - Ударопрочность | ISO 10545-5 | ≥ 0,80 | ≥ 0,80 | ≥ 0,80 |
| | Resistenza all'abrasione profonda* - Deep scratch resistance* - Résistance à l'abrasion profonde* - Widerstand gegen Tiefenverschleiß* - Устойчивость к глубокому истиранию* | ISO 10545-6 | Conforme - In accordance Conforme - Erfüllt - Соответствует | - | Conforme - In accordance Conforme - Erfüllt - Соответствует |
| | Coefficiente di dilatazione termica lineare* - Thermal linear expansion - coefficient* - Coefficient de dilatation thermique linéaire* - Koeffizient der linearen thermischen Dehnung* - Кoeffициент линейного теплового расширения* | ISO 10545-8 | = 7 (10 ⁻⁶ °C ⁻¹) | = 7 (10 ⁻⁶ °C ⁻¹) | = 7 (10 ⁻⁶ °C ⁻¹) |
| | Resistenza agli sbalzi termici* - Thermal shock resistance* Résistance aux écarts de température* - Temperaturwechsel Beständigkeit* - Устойчивость к тепловому перепаду* | ISO 10545-9 | Resistente - Resistant Résistante - Beständig - Стойкий | Resistente - Resistant Résistante - Beständig - Стойкий | Resistente - Resistant Résistante - Beständig - Стойкий |
| | Dilatazione all'umidità* - Expansion in humidity* Dilatation à l'humidité* - Feuchtigkeitsausdehnung* Расширение в условиях влажности* | ISO 10545-10 | ≤ 0,1 (mm/m) | ≤ 0,1 (mm/m) | ≤ 0,1 (mm/m) |
| | Resistenza al cavillo - Crazing resistance Résistance aux craquelures - Haariß-Beständigkeit Устойчивость эмали к кракелюру | ISO 10545-11 | - | Conforme - In accordance Conforme - Erfüllt - Соответствует | - |
| | Resistenza al gelo* - Frost resistance* Résistance au gel* - Frostbeständigkeit* Морозоустойчивость* | ISO 10545-12 | Resistente - Resistant Résistante - Beständig - Стойкий | Resistente - Resistant Résistante - Beständig - Стойкий | Resistente - Resistant Résistante - Beständig - Стойкий |
| | Resistenza all'attacco chimico* - Resistance to chemical attack* - Résistance à l'attaque chimique* - Beständigkeit gegen Chemikalien* - Устойчивость к химическому воздействию* | ISO 10545-13 | Resistente - Resistant Résistante - Beständig - Стойкий | Resistente - Resistant Résistante - Beständig - Стойкий | Resistente - Resistant Résistante - Beständig - Стойкий |
| | Carico statico - Static load Charge statique - Statische Last Статическая нагрузка | EN 12825 | - | - | 60x60 KN>7,0 Centro lato - Side centre - Au centre latéralement Mitte Seite - По центру грани Diagonale - Diagonal - En diagonale Diagonal - По диагонали KN>8,0 |
| | Classe di carico di rottura*** - Breaking load class*** Classe de charge de rupture*** - Bruchlastklasse*** Класс стойкости к разрушающей нагрузке*** | EN 1339 | - | - | U11 T11 |
| | Resistenza alle macchie* - Resistance to stains* Résistance aux taches* - Fleckenbeständigkeit* Устойчивость к образованию пятен* | ISO 10545-14 | Pulibile - Cleanable Nettoyable - Leicht zu reinigen Чистящийся | Pulibile - Cleanable Nettoyable - Leicht zu reinigen Чистящийся | Pulibile - Cleanable Nettoyable - Leicht zu reinigen Чистящийся |
| | Resistenza allo scivolamento** - Slip resistance** Résistance au glissement** - Rutschhemmende Eigenschaft** Сопrotвление скольжению** | DIN 51130 - DIN 51097 ▲ ANSI A326.3 | R9 Matt 160x320 - 120x278 R9 A Matt | - | R11 C Wet DCOF ≥ 0,55 |
| | Resistenza all'abrasione superficiale - Surface abrasion resistance - Résistance à l'abrasion superficielle - Widerstand gegen Oberflächenschleiß - Сопrotвление на изгиб и усилию на изломе | EN ISO 10545-7 | - | Test disponibili in azienda Tests available at our company Tests disponibles en usine Prüfungsprotokolle beim Werk erhältlich Протоколы испытаний хранятся в компании | - |
| | Durezza Mohs - Mohs hardness Dureté Mohs - Ritzhärte nach Mohs - Устойчивость к изгибу | EN 101 | Coeff. 6 | Coeff. 5 | Coeff. 6 |
| | Spessore nominale - Nominal Thickness Épaisseur nominale - Nominalstärke Номинальная толщина | | 6 mm 160x320 - 120x278 9 mm 120x120 - 60x120 - 80x80 40x80 - 60x60 - 30x60 - 30x30 | 9 mm 120x120 - 60x120 | 20 mm |

* Valori medi riferiti agli ultimi due anni di produzione e relativi alla finitura naturale del prodotto - Average values referred to the last two years of production and related to the matt finish of the product - Valeurs moyennes des deux dernières années de production et relatifs à la finition naturelle du produit - Durchschnittswerte, die sich auf die letzten zwei Produktionsjahre beziehen und auf die matte Oberfläche - Средние значения относятся к последним двум годам производства и натуральной отделке поверхности

** Valori relativi alla finitura naturale del prodotto ed a test effettuati da laboratori esterni accreditati, disponibili in azienda; ci rendiamo disponibili alla verifica dell'eventuale lotto interessato all'acquisto. - As far as values relating to the matt finish of the product and to tests carried out by certified external laboratories whose results are available upon request at Headoffice, we are willing to check the lot you are interested in purchasing. - Valeurs se référant à la finition naturelle du produit selon des tests effectués par des laboratoires extérieurs accrédités et à la disposition de toute personne intéressée auprès de nos bureaux; nous sommes disponibles pour le contrôle de l'éventuel lot concerné par l'achat. - Werte bezogen auf das natürliche Produktfinish und in anerkannten externen Labors geprüft, im Unternehmen erhältlich; für eventuelle Prüfungen der zu erwerbenden Warenposten stehen wir gern zur Verfügung. - Значения, касающиеся натуральных характеристик изделий и тестов, выполненных внешними авторизованными лабораториями, имеются в компании. Мы готовы выполнить проверку партии товара, которую намереваетесь приобрести.

*** Dato riferito al formato 60x60 cm. - Detail referred to the 60x60 cm size. - Donnée se rapportant au format 60x60 cm. - Auf die Formate 60x60 cm bezogen. - Значения, касающиеся натуральных характеристик изделий и тестов.

• Per prodotti chimici di uso domestico e additivi per piscina. - For domestic chemicals and swimming pool additives. - Pour produits chimiques à usage domestique et additifs pour piscines. - Für chemische Produkte für den Hausgebrauch und Schwimmbadzusätze. - Для бытовых химикатов и добавок для бассейнов.

▲ Valori wet DCOF specifici disponibili in azienda - Wet DCOF specific values available at the company - Valeurs wet DCOF spécifiques disponibles à l'usine - Prüfwerte Wet DCOF stehen im Werk zur Verfügung - Показатели wet DCOF доступны при запросе

Le tonalità dei campioni sono da considerarsi puramente indicative. - Tones of samples are indicative. - Les tonalités des échantillons sont purement indicatives. Die farbtonen der Muster sind als rein indicativ zu betrachten. - Тона образцов ориентировочные.

Relate Flame

Design synergy

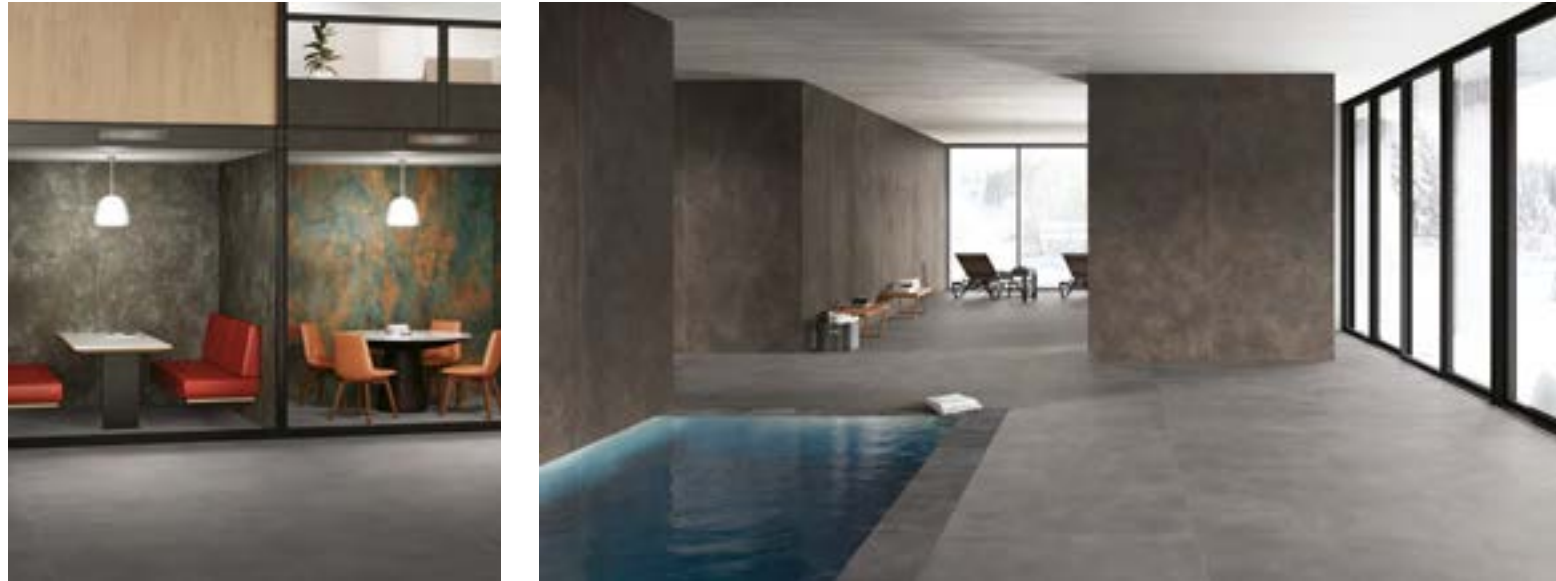

RELATE FLAME è la traduzione di un progetto in materia. La collezione è la sintesi di uno studio sui trend presenti nello scenario architettonico contemporaneo. Cromatismi dinamici e bruciature connotano le superfici che parlano un linguaggio deciso, espressione progettuale della trasformazione della materia.

RELATE FLAME is the translation of a project into material. The collection is the sum result of a study into the current trends on the contemporary architectural scene. Dynamic patterns of colour and burnishing characterise surfaces that speak a distinct language. The expression of how material is transformed.

RELATE FLAME est la traduction d'un projet en matière. La collection est la synthèse d'une étude sur les tendances présentes dans le contexte architectural contemporain. Des chromatismes dynamiques et des brûlures animent les surfaces qui parlent un langage résolu, expression conceptuelle de la transformation de la matière.

RELATE FLAME ist die Übersetzung eines Projekts in Materie. Die Kollektion ist die Synthese einer Studie der aktuellen Trends in der zeitgenössischen Architektur. Dynamische Farben und Brandstellen prägen die Oberflächen mit einer deutlichen Sprache, dem planerischen Ausdruck der sich verwandelnden Materie.

RELATE FLAME – это материальное воплощение проекта. Эта коллекция представляет собой синтез исследования тенденций, представленных в современной архитектурной среде. Динамичные цвета и прожоги являются характеристиками этих поверхностей, говорящих решительным языком, выражающим проект трансформации материи.



Info
Resources
Tools



METAL LOOK

Floor: MINE 120x120 MATT RT
Wall: BLIZZARD 120x278 MATT RT

Relate Flame



METAL LOOK

Colori - Formati

Colors - Sizes

120x278 6 mm MATT RT
120x120 . 60x120 . 60x60 . 30x60 . 30x30 9 mm MATT RT

BLIZZARD



VEIL



MINE



REEF



MOSS



BLAZE



6 mm

MATT RT

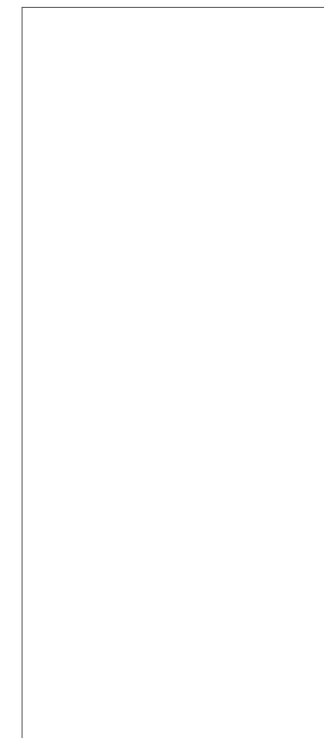

120x278
47²/₈"x109⁷/₁₆"

9 mm

MATT RT

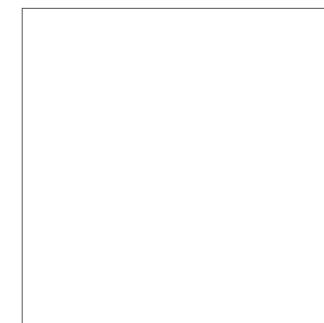

120x120
47²/₈"x47²/₈"



60x120
23⁵/₈"x47²/₈"



60x60
23⁵/₈"x23⁵/₈"

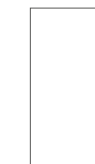

30x60
11⁵/₁₆"x23⁵/₈"







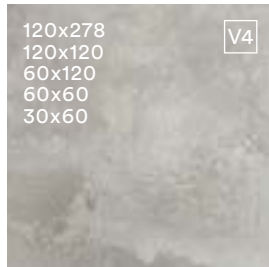
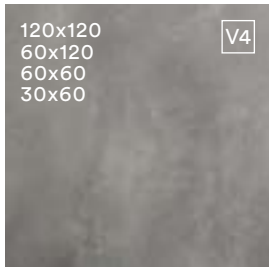

30x30
11⁵/₁₆"x11⁵/₁₆"

Relate Flame

La gamma

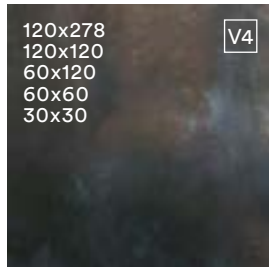
The range

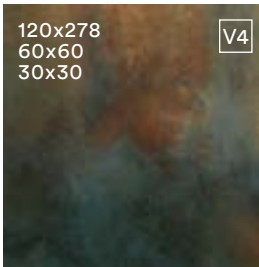
| | BLIZZARD | VEIL  | MINE |
|---------|--------------------------------------------------------------------------------------------------------------------------------------------------------|-------------------------------------------------------------------------------------------------------------------------------------------|--------------------------------------------------------------------------------------------------------------------------------------------------------|
| MATT RT |  <p>120x278 120x120 60x120 60x60 30x60</p> <p>V4</p> |  <p>120x120 60x120 60x60 30x60</p> <p>V4</p> |  <p>120x278 120x120 60x120 60x60 30x60</p> <p>V4</p> |
| | REEF | MOSS  | BLAZE  |
| |  <p>120x278 120x120 60x120 60x60 30x30</p> <p>V4</p> |  <p>120x278 60x60 30x30</p> <p>V4</p> |  <p>120x278 60x60 30x30</p> <p>V4</p> |

RT Rettificato, squadrato, monocalibro. - Rectified, squared, one caliber. - Rectifié, mis d'équerre et monocalibre. - Rektifiziert, rechtwinkelig und Ein kaliber. - Ректифицированный, одного калибра.



METAL LOOK

Floor: (IN) VEIL 120x120 MATT RT, (OUT) ARTHIS VAPOR 30x120 AEXTRA20 RT R11 C
Wall: PORTRAITS COMBLANCHIEN 120x278 MATT RT

CARATTERISTICHE TECNICHE

TILE PERFORMANCE DATA - NOTES TECHNIQUES - TECHNISCHE AUSKÜNFTE - ТЕХНИЧЕСКАЯ ХАРАКТЕРИСТИКА

Classificazione secondo EN ISO 14411 ISO 13006 annesso G gruppo Bla con Ev ≤0,5% - Classification in accordance with EN ISO 14411 ISO 13006 annex G standards Bla with Ev ≤ 0,5% - Classification selon EN ISO 14411 ISO 13006 annexe G groupe Bla avec Ev ≤0,5% - Klassifizierung gemäß EN ISO 14411 ISO 13006 anlage G Gruppe Bla mit Ev ≤0,5% - Классификация в соответствии с EN ISO 14411 ISO 13006, приложение G, стандарт Bla, где Ev ≤0,5%

| | 120x278 cm 47 ^{7/8} "x109 ^{7/16} " 6 mm MATT RT | 120x120 cm 47 ^{7/8} "x47 ^{7/8} " 9 mm MATT RT | 60x120 cm 23 ^{5/8} "x47 ^{7/8} " 9 mm MATT RT | 60x60 cm 23 ^{5/8} "x23 ^{5/8} " 9 mm MATT RT | 30x60 cm 11 ^{13/16} "x23 ^{5/8} " 9 mm MATT RT | 30x30 cm 11 ^{13/16} "x11 ^{13/16} " 9 mm MATT RT |
|----------|-----------------------------------------------------------------------------------|---------------------------------------------------------------------------------|--------------------------------------------------------------------------------|-------------------------------------------------------------------------------|---------------------------------------------------------------------------------|-----------------------------------------------------------------------------------|
| Blizzard | ● | ● | ● | ● | ● | ● |
| Veil | ● | ● | ● | ● | ● | ● |
| Mine | ● | ● | ● | ● | ● | ● |
| Reef | ● | ● | ● | ● | ● | ● |
| Moss | ● | ● | ● | ● | ● | ● |
| Blaze | ● | ● | ● | ● | ● | ● |

| | Battiscopa - Bullnose Plinthe - Sockel Плинтус 7,2x60 cm 2 ^{13/16} "x23 ^{5/8} " MATT | Scalino - Step tread Nez de marche - Stufe Cotto-Art Фронтальная ступень 33x120 cm 13"x47 ^{7/8} " MATT | Angolare - Step tread corner Pièce angulaire - Stufencke Угловая ступень 33x60 cm 13"x23 ^{5/8} " MATT | 33x33 cm 13"x13" MATT |
|----------|-------------------------------------------------------------------------------------------------------------------------------------|----------------------------------------------------------------------------------------------------------------------------------------------|---------------------------------------------------------------------------------------------------------------------------------------------|------------------------------------|
| Blizzard | ● | ● | ● | ● |
| Veil | ● | ● | ● | ● |
| Mine | ● | ● | ● | ● |
| Reef | ● | ● | ● | ● |
| Moss | ● | ● | ● | ● |
| Blaze | ● | ● | ● | ● |

| | CARATTERISTICA TECNICA TECHNICAL CHARACTERISTIC CARACTERISTIQUE TECHNIQUE TECHNISCHE DATEN ТЕХНИЧЕСКАЯ ХАРАКТЕРИСТИКА | METODO DI PROVA TESTS METHOD METHODE D'ESSAI TESTMETHODE МЕТОД ИСПЫТАНИЯ | VALORE * MEDIO "CAESAR" AVERAGE "CAESAR" VALUE* VALEUR * MOYEN "CAESAR" "CAESAR" DURCHSCHNITTSWERT* СРЕДНЕЕ ЗНАЧЕНИЕ "CAESAR"* |
|--|-------------------------------------------------------------------------------------------------------------------------------------------------------------------------------------------------------------------------------------|--------------------------------------------------------------------------------------|--------------------------------------------------------------------------------------------------------------------------------------------|
| | Dimensione - Size Dimension - Abmessungen - Размер | ISO 10545-2 | Conforme - In accordance Conforme - Erfüllt - Соответствует |
| | Assorbimento d'acqua* - Water absorption* Absorption d'eau* - Wasseraufnahme* - % Поглощения воды* | ISO 10545-3 | ≤ 0,1% |
| | Resistenza alla flessione* - Bending strength* Résistance à la flexion* - Biegezugfestigkeit* - Упругость* | ISO 10545-4 | Conforme - In accordance Conforme - Erfüllt - Соответствует |
| | Resistenza all'abrasione profonda* - Deep scratch resistance* Résistance à l'abrasion profonde* - Widerstand gegen Tiefenverschleiß* Устойчивость к глубокому истиранию* | ISO 10545-6 | Conforme - In accordance Conforme - Erfüllt - Соответствует |
| | Coefficiente di dilatazione termica lineare* - Thermal linear expansion coefficient* Coefficient de dilatation thermique linéaire* - Koeffizient der linearen thermischen Dehnung* - Коэффициент линейного теплового расширения* | ISO 10545-8 | = 7 (10 ⁻⁶ °C ⁻¹) |
| | Resistenza agli sbalzi termici* - Thermal shock resistance* Résistance aux écarts de température* - Temperaturwechsel Beständigkeit* Устойчивость к тепловому перепаду* | ISO 10545-9 | Conforme - In accordance Conforme - Erfüllt - Соответствует |
| | Dilatazione all'umidità* - Expansion in humidity* Dilatation à l'humidité* - Feuchtigkeitsausdehnung* Расширение в условиях влажности* | ISO 10545-10 | ≤ 0,1 (mm/m) |
| | Resistenza al gelo* - Frost resistance* Résistance au gel* - Frostbeständigkeit* - Морозоустойчивость* | ISO 10545-12 | Resistente - Resistant Résistante - Beständig - Стойкий |
| | Resistenza all'attacco chimico* - Resistance to chemical attack* Résistance à l'attaque chimique* - Beständigkeit gegen Chemikalien* Устойчивость к химическому воздействию* | ISO 10545-13 | Resistente - Resistant Résistante - Beständig - Стойкий |
| | Resistenza alle macchie* - Resistance to stains* Résistance aux taches* - Fleckenbeständigkeit* Устойчивость к образованию пятен* | ISO 10545-14 | Pulibile - Cleanable Nettoyable - Leicht zu reinigen - Чистящийся |
| | Resistenza allo scivolamento** - Slip resistance** Résistance au glissement** - Rutschhemmende Eigenschaft** Сопротивление скольжению** | DIN 51130 - DIN 51097 ▲ ANSI A326.3 | R9 Matt 120x278 Wet DCOF ≥ 0,42 |
| | Spessore nominale - Nominal Thickness Épaisseur nominale - Nominalstärke Номинальная толщина | | 6 mm 120x278 9 mm 120x120 - 60x120 - 60x60 - 30x60 - 30x30 |

* Valori medi riferiti agli ultimi due anni di produzione e relativi alla finitura naturale del prodotto - Average values referred to the last two years of production and related to the matt finish of the product - Valeurs moyennes des deux dernières années de production et relatifs à la finition naturelle du produit - Durchschnittswerte, die sich auf die letzten zwei Produktionsjahre beziehen und auf die matte Oberfläche - Средние значения относятся к последним двум годам производства и натуральной отделке поверхности

** Valori relativi alla finitura naturale del prodotto ed a test effettuati da laboratori esterni accreditati, disponibili in azienda; ci rendiamo disponibili alla verifica dell'eventuale lotto interessato all'acquisto. - As far as values relating to the matt finish of the product and to tests carried out by certified external laboratories whose results are available upon request at Headoffice, we are willing to check the lot you are interested in purchasing. - Valeurs se référant à la finition naturelle du produit selon des tests effectués par des laboratoires extérieurs accrédités et à la disposition de toute personne intéressée auprès de nos bureaux; nous sommes disponibles pour le contrôle de l'éventuel lot concerné par l'achat. - Werte bezogen auf das natürliche Produktfinish und in anerkannten externen Labors geprüft, im Unternehmen erhältlich; für eventuelle Prüfungen der zu erwerbenden Warenposten stehen wir gern zur Verfügung. Значения, касающиеся натуральных характеристик изделий и тестов, выполненных внешними авторизованными лабораториями, имеются в компании. Мы готовы выполнить проверку партии товара, которую намереваетесь приобрести.

• Per prodotti chimici di uso domestico e additivi per piscina. - For domestic chemicals and swimming pool additives. - Pour produits chimiques à usage domestique et additifs pour piscines. - Für chemische Produkte für den Hausgebrauch und Schwimmbadzusätze. - Для бытовых химикатов и добавок для бассейнов.

▲ Valori wet DCOF specifici disponibili in azienda - Wet DCOF specific values available at the company - Valeurs wet DCOF spécifiques disponibles à l'usine - Prüfwerte Wet DCOF stehen im Werk zur Verfügung - Показатели wet DCOF доступны при запросе

| IMBALLI - PACKAGING - CONDITIONNEMENT - VERPACKUNGS-EINHEITEN - УПАКОВКА | | | | | | | |
|--------------------------------------------------------------------------|---------------------------------------------|------------------------------------------|--------|--------|---------------------------|---------|----------|
| Formato - Size - Format - Формат | | Scatola - Box - Boîte - Karton - Коробка | | | Pallet - Palette - Палета | | |
| CM | INCHES | PZ | MQ | KG | SC | MQ | KG |
| 120x278 | 47 ^{7/8} "x109 ^{7/16} " | 1 | 3,3221 | ~49,56 | 18 | 59,7978 | ~892,08 |
| 120x120 | 47 ^{7/8} "x47 ^{7/8} " | 2 | 2,856 | ~62,00 | 20 | 57,12 | ~1240,00 |
| 60x120 | 23 ^{5/8} "x47 ^{7/8} " | 2 | 1,44 | ~30,40 | 35 | 50,40 | ~1064,00 |
| 60x60 | 23 ^{5/8} "x23 ^{5/8} " | 4 | 1,44 | ~28,40 | 30 | 43,20 | ~852,00 |
| 30x60 | 11 ^{13/16} "x23 ^{5/8} " | 7 | 1,26 | ~25,00 | 40 | 50,40 | ~1000,00 |
| 30x30 | 11 ^{13/16} "x11 ^{13/16} " | 12 | 1,08 | ~21,60 | 48 | 51,84 | ~1036,80 |

RT Rettificato, squadrato, monocalibro. - Rectified, squared, one caliber. - Rectifié, mis d'equerre et monocalibre. - Rektifiziert, rechteckig und Ein kaliber. - Ректифицированный, одного калибра.

** Disponibile solo su richiesta. - Manufactured only upon special request. - Seulement sur demande. - Nur auf Anfrage. - Производится только по заказу.

Si raccomanda l'utilizzo di una fuga di 2/3 mm al fine di semplificare le operazioni di posa e ottimizzare la naturalezza del risultato finale. - We recommend you a 2/3 mm grout joint to simplify the laying and optimize the naturalness of the final result. - Un joint de 2/3 mm est conseillé afin de simplifier les opérations de pose et optimiser l'effet naturel du résultat final. - Es wird empfohlen mit einer Fuge von 2/3 mm zu arbeiten, um am Ende den Verlegevorgang zu vereinfachen und die bestmögliche Natürlichkeit der Arbeit zu erzielen. - Для облегчения операций укладки и повышения натуральности вида конечного результата рекомендуется выполнять шов шириной 2-3 мм.

Al fine di facilitare la manutenzione ordinaria si raccomanda di effettuare un lavaggio acido dopo 48 ore dalla stuccatura con un acido specifico per grès porcellanato. - In order to favour the ordinary maintenance procedures, it is recommended to carry out an acid wash of the surface after 48 hours from grout filling using an acid agent specific for porcelain stoneware tiles. - Afin de faciliter l'entretien ordinaire de votre carrelage, nous vous conseillons de le laver 48 heures après le colmatage des joints, avec un acide spécifique pour grès cérame. - Um die Instandhaltung zu erleichtern, empfiehlt es sich 48 Stunden nach der Stuckatur mit einer sauren Lösung speziell für Feinsteinzeug zu waschen. - Чтобы упростить уход за плиткой, спустя 48 часов после затирки швов рекомендуется выполнить обработку кислотным продуктом, пригодным для керамогранита.

Le tonalità dei campioni sono da considerarsi puramente indicative. - Tones of samples are indicative. - Les tonalités des échantillons sont purement indicatives. Die farböne der Muster sind als rein indicativ zu betrachten. - Тона образцов ориентировочные.

Concrete Look

Collezioni pensate per esaltare la tua creatività, di diversa ispirazione: dalle mille anime del cemento alla tradizione del terrazzo veneziano, passando per resine e cotti.

Collections designed to enhance your creativity, with a variety of inspirations: from the thousand souls of concrete to the tradition of Venetian Terrazzo, including resin and cotto.

Des collections créées pour accentuer votre créativité, avec plusieurs inspiration : des mille âmes du ciment à la tradition de la terrasse vénitienne, en passant par les résines et les terres cuites.

Kollektionen verschiedenster Art unterstreichen Ihre Kreativität: von den tausend Seelen des Betons über Harze und Terrakotta bis hin zum traditionellen Terrazzoboden.

Коллекции, которые дают простор фантазии: от многоликого цемента до традиционного венецианского терраццо, а также смол и терракоты.



Concrete Look

The collections

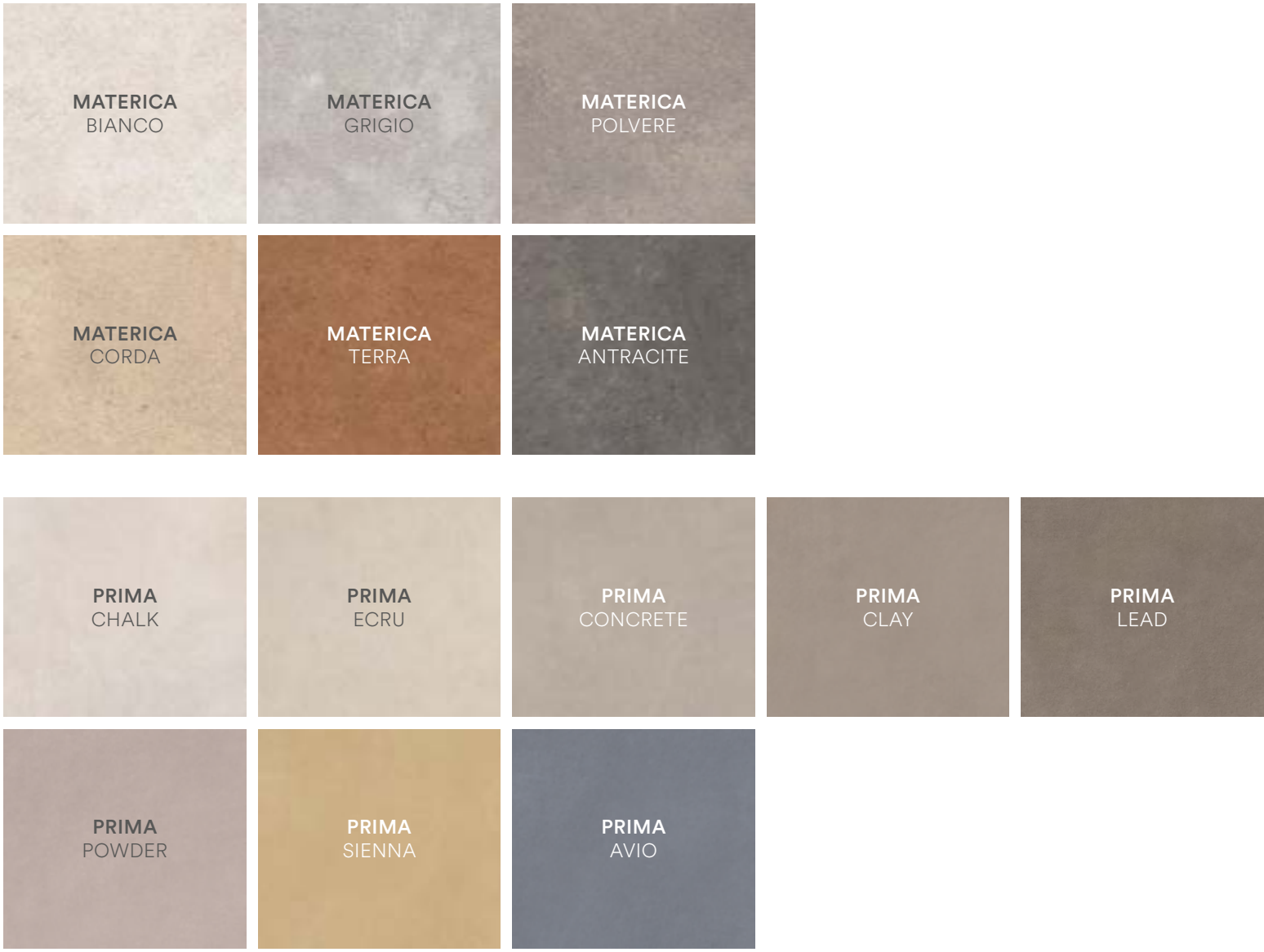
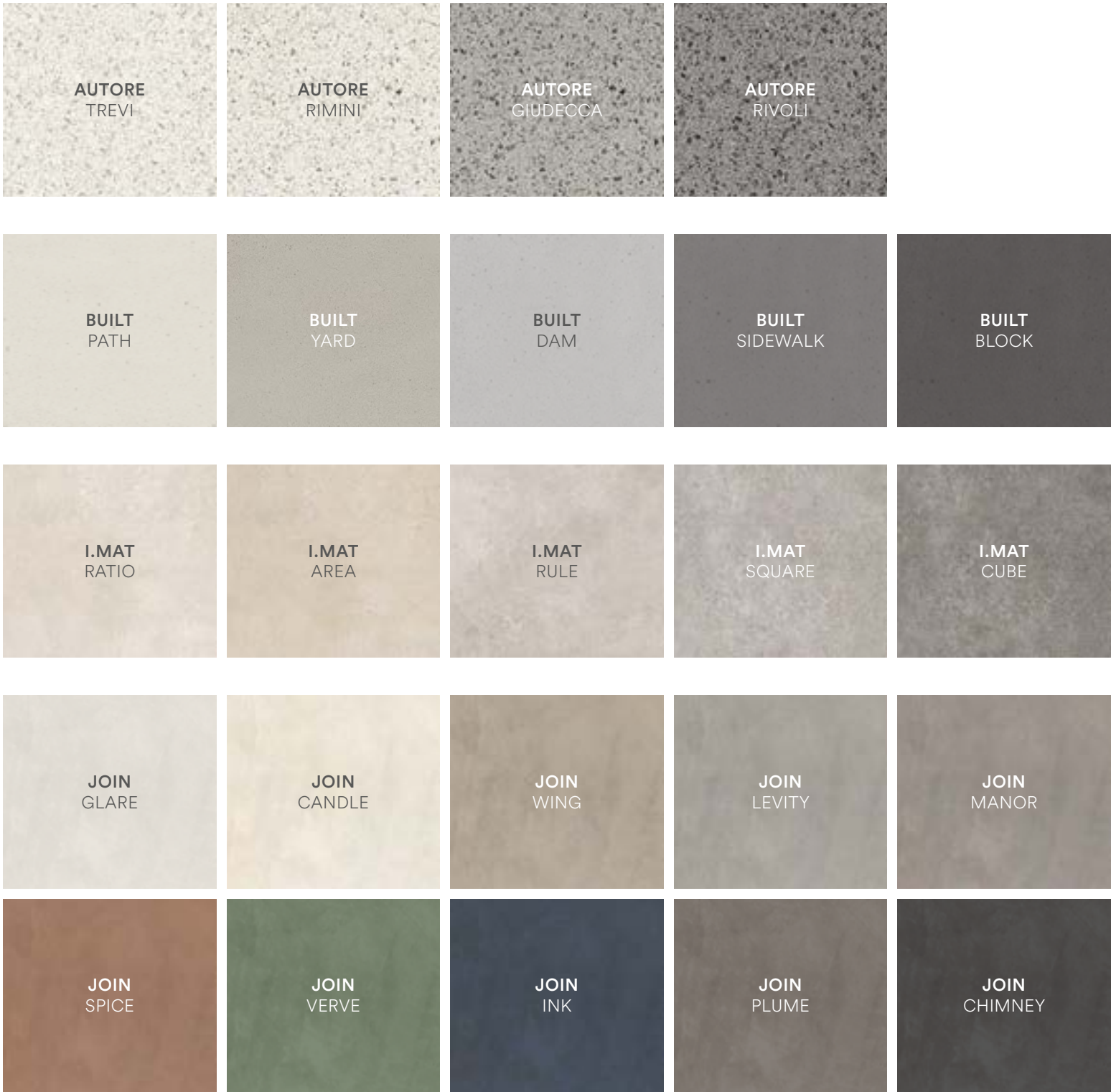

Autore

A new ceramic masterpiece



Autore riaccende i riflettori sul terrazzo veneziano, tra le creazioni più originali e rinomate della tradizione artigianale italiana, riscrivendo la sua storia fatta di amore per la materia e maestria compositiva con il linguaggio dei nostri giorni.

Autore turns the spotlight onto Venetian terrazzo floors are amongst the most original and renowned creations of the history of Italian craftsmanship. Autore rewrites and retells a story about passion and skill bringing the terrazzo style into modern culture.

Autore rallume les projecteurs sur la terrasse vénitienne, l'une des créations les plus originales et les plus renommées de la tradition artisanale italienne, réécrivant ainsi son histoire faite d'amour pour la matière et de maestria créative avec les codes actuels.

Autore richtet den Scheinwerfer wieder auf den Terrazzoboden, eine der interessantesten und renommiertesten Kreationen der italienischen Handwerkstradition. Und schreibt seine auf der Liebe zur Materie und auf kompositorischer Meisterschaft gegründete Geschichte in der Sprache unserer Tage neu.

Коллекция Autore освещает софитами венецианский терраццо, одно из самых оригинальных и известных творений итальянских мастеров, переписывая современным языком эту историю любви к материалу и мастерству композиции.



Info
Resources
Tools



Colori - Formati

Colors - Sizes

120x120 . 60x60 . 30x60 9 mm MATT RT

TREVI



RIMINI



GIUDECCA



RIVOLI

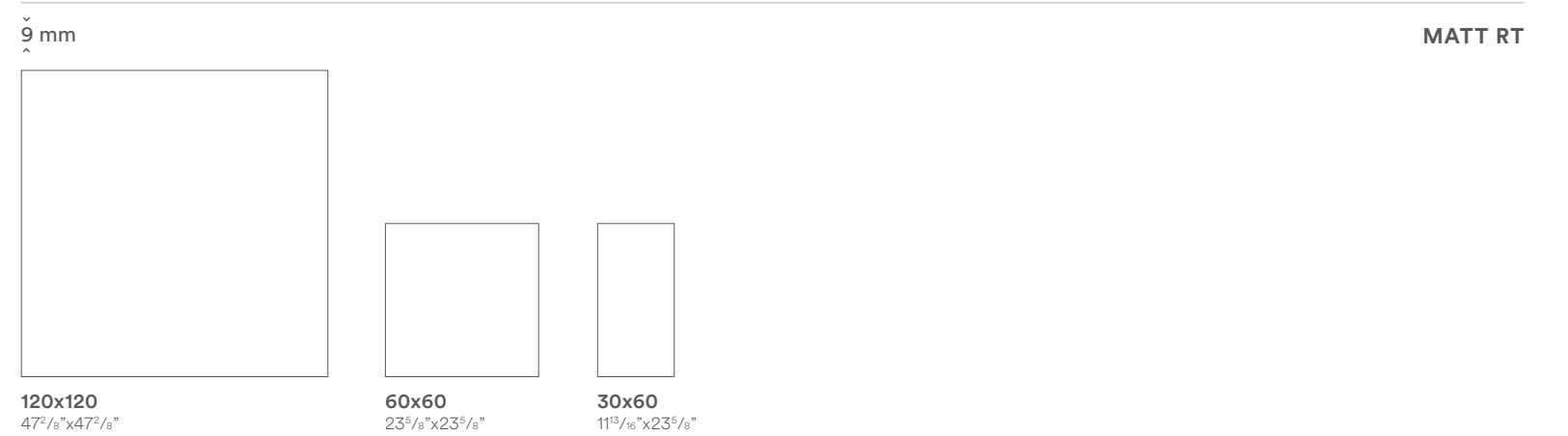
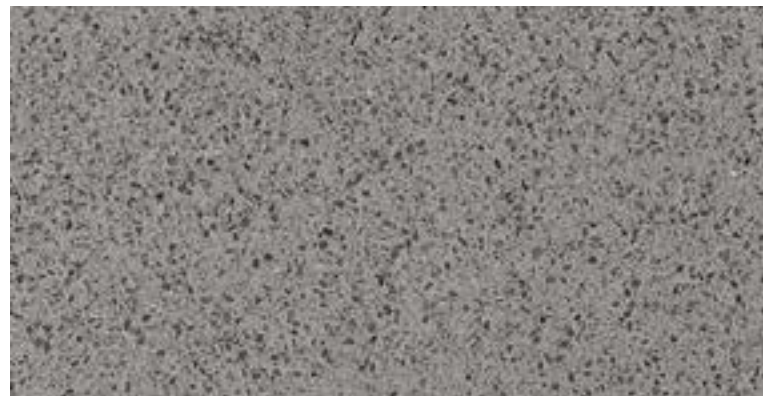

La gamma

The range

| | TREVI | RIMINI | GIUDECCA | RIVOLI |
|---------|------------------------------------|------------------------|------------------------|------------------------|
| MATT RT | <p>120x120 60x60 30x60</p> | <p>60x60 30x60</p> | <p>60x60 30x60</p> | <p>60x60 30x60</p> |

*La liste a jour des produits et formats des series certifiees QB-UPEC est disponible en usine.

RT Rettificato, squadrato, monocalibro. - Rectified, squared, one caliber. - Rectifié, mis d'equerre et monocalibre. - Rektifiziert, rechtwinkelig und Ein kaliber. - Ректифицированный, одного калибра.



| | 120x120 cm 47 ² / ₈ "x47 ² / ₈ " 9 mm MATT RT | 60x60 cm 23 ⁵ / ₈ "x23 ⁵ / ₈ " 9 mm MATT RT | 30x60 cm 11 ³ / ₈ "x23 ⁵ / ₈ " 9 mm MATT RT |
|----------|----------------------------------------------------------------------------------------------------|--------------------------------------------------------------------------------------------------|--------------------------------------------------------------------------------------------------|
| Trevi | ● | ● | ● |
| Rimini | ● | ● | ● |
| Giudecca | ● | ● | ● |
| Rivoli | ● | ● | ● |

| | Battiscopa - Bullnose Plinthe - Sockel Плинтус 7,2x60 cm 2 ⁹ / ₈ "x23 ⁵ / ₈ " MATT | Scalino - Step tread Nez de marche - Stufe Cotto-Art Фронтальная ступень ** 33x60 cm 13"x23 ⁵ / ₈ " MATT | Angolare - Step tread corner Pièce angulaire - Stufencke Угловая ступень ** 33x33 cm 13"x13" MATT |
|----------|-----------------------------------------------------------------------------------------------------------------------------------------------|--------------------------------------------------------------------------------------------------------------------------------------------------|---------------------------------------------------------------------------------------------------------------------|
| Trevi | ● | ● | ● |
| Rimini | ● | ● | ● |
| Giudecca | ● | ● | ● |
| Rivoli | ● | ● | ● |

IMBALLI - PACKAGING - CONDITIONNEMENT - VERPACKUNGS-EINHEITEN - УПАКОВКА

| Formato - Size - Format - Формат | | Scatola - Box - Boîte - Karton - Коробка | | | Pallet - Palette - Палета | | |
|----------------------------------|-------------------------------------------------------------------|------------------------------------------|-------|--------|---------------------------|-------|----------|
| CM | INCHES | PZ | MQ | KG | SC | MQ | KG |
| 120x120 | 47 ² / ₈ "x47 ² / ₈ " | 2 | 2,856 | -62,00 | 20 | 57,12 | -1240,00 |
| 60x60 | 23 ⁵ / ₈ "x23 ⁵ / ₈ " | 4 | 1,44 | -28,40 | 30 | 43,20 | -852,00 |
| 30x60 | 11 ³ / ₈ "x23 ⁵ / ₈ " | 7 | 1,26 | -25,20 | 40 | 50,40 | -1008,00 |

RT Rettificato, squadrato, monocalibro. - Rectified, squared, one caliber. - Rectifié, mis d'equerre et monocalibre. - Rektifiziert, rechtwinkelig und Ein kaliber. - Ректифицированный, одного калибра.

** Disponibile solo su richiesta. - Manufactured only upon special request. - Seulement sur demande. - Nur auf Anfrage. - Производится только по заказу.

Si raccomanda l'utilizzo di una fuga di 2/3 mm al fine di semplificare le operazioni di posa e ottimizzare la naturalezza del risultato finale. - We recommend you a 2/3 mm grout joint to simplify the laying and optimize the naturalness of the final result. - Un joint de 2/3 mm est conseillé afin de simplifier les opérations de pose et optimiser l'effet naturel du résultat final. - Es wird empfohlen mit einer Fuge von 2/3 mm zu arbeiten, um am Ende den Verlegvorgang zu vereinfachen und die bestmögliche Natürlichkeit der Arbeit zu erzielen. - Для облегчения операций укладки и повышения натуральности вида конечного результата рекомендуется выполнять шов шириной 2-3 мм.

Al fine di facilitare la manutenzione ordinaria si raccomanda di effettuare un lavaggio acido dopo 48 ore dalla stuccatura con un acido specifico per grès porcellanato. - In order to favour the ordinary maintenance procedures, it is recommended to carry out an acid wash of the surface after 48 hours from grout filling using an acid agent specific for porcelain stoneware tiles. - Afin de faciliter l'entretien ordinaire de votre carrelage, nous vous conseillons de le laver 48 heures après le colmatage des joints, avec un acide spécifique pour grès cérame. - Um die Instandhaltung zu erleichtern, empfiehlt es sich 48 Stunden nach der Stuckatur mit einer sauren Lösung speziell für Feinsteinzeug zu waschen. - Чтобы упростить уход за плиткой, спустя 48 часов после затирки швов рекомендуется выполнить обработку кислотным продуктом, пригодным для керамогранита.

CARATTERISTICHE TECNICHE

TILE PERFORMANCE DATA - NOTES TECHNIQUES - TECHNISCHE AUSKÜNFTE - ТЕХНИЧЕСКАЯ ХАРАКТЕРИСТИКА

Classificazione secondo EN ISO 14411 ISO 13006 annesso G gruppo Bla con Ev ≤0,5% - Classification in accordance with EN ISO 14411 ISO 13006 annex G standards Bla with Ev ≤ 0,5% - Classification selon EN ISO 14411 ISO 13006 annexe G groupe Bla avec Ev ≤0,5% - Klassifizierung gemäß EN ISO 14411 ISO 13006 anlage G Gruppe Bla mit Ev ≤0,5% - Классификация в соответствии с EN ISO 14411 ISO 13006, приложение G, стандарт Bla, где Ev ≤0,5%

| | CARATTERISTICA TECNICA TECHNICAL CHARACTERISTIC CARACTERISTIQUE TECHNIQUE TECHNISCHE DATEN ТЕХНИЧЕСКАЯ ХАРАКТЕРИСТИКА | METODO DI PROVA TESTS METHOD METHODE D'ESSAI TESTMETHODE МЕТОД ИСПЫТАНИЯ | VALORE * MEDIO "CAESAR" AVERAGE "CAESAR" VALUE* VALEUR * MOYEN "CAESAR" "CAESAR" DURCHSCHNITTSWERT* СРЕДНЕЕ ЗНАЧЕНИЕ "CAESAR"* |
|--|-------------------------------------------------------------------------------------------------------------------------------------------------------------------------------------------------------------------------------------|--------------------------------------------------------------------------------------|--------------------------------------------------------------------------------------------------------------------------------------------|
| | Dimensione - Size Dimension - Abmessungen - Размер | ISO 10545-2 | Conforme - In accordance Conforme - Erfüllt - Соответствует |
| | Assorbimento d'acqua* - Water absorption* Absorption d'eau* - Wasseraufnahme* - % Поглощения воды* | ISO 10545-3 | ≤ 0,1% |
| | Resistenza alla flessione* - Bending strength* Résistance à la flexion* - Biegezugfestigkeit* - Упругость* | ISO 10545-4 | Conforme - In accordance Conforme - Erfüllt - Соответствует |
| | Sforzo di rottura (S) - Breaking strength Charge de rupture - Bruchlast - Разрушающее усилие | ISO 10545-4 | Sps ≥ 7,5 mm S ≥ 1300 N |
| | Resistenza all'urto - Impact resistance Résistance au choc - Schlagfestigkeit - Ударопрочность | ISO 10545-5 | ≥ 0,80 |
| | Resistenza all'abrasione profonda* - Deep scratch resistance* Résistance à l'abrasion profonde* - Widerstand gegen Tiefenverschleiß* Устойчивость к глубокому истиранию* | ISO 10545-6 | Conforme - In accordance Conforme - Erfüllt - Соответствует |
| | Coefficiente di dilatazione termica lineare* - Thermal linear expansion coefficient* Coefficient de dilatation thermique linéaire* - Koeffizient der linearen thermischen Dehnung* - Коэффициент линейного теплового расширения* | ISO 10545-8 | ≈ 7 (10 ⁻⁶ °C ⁻¹) |
| | Resistenza agli sbalzi termici* - Thermal shock resistance* Résistance aux écarts de température* - Temperaturwechsel Beständigkeit* Устойчивость к тепловому перепаду* | ISO 10545-9 | Resistente - Resistant Résistante - Beständig - Стойкий |
| | Dilatazione all'umidità* - Expansion in humidity* Dilatation à l'humidité* - Feuchtigkeitsausdehnung* Расширение в условиях влажности* | ISO 10545-10 | ≤ 0,1 (mm/m) |
| | Resistenza al gelo* - Frost resistance* Résistance au gel* - Frostbeständigkeit* - Морозоустойчивость* | ISO 10545-12 | Resistente - Resistant Résistante - Beständig - Стойкий |
| | Resistenza all'attacco chimico* - Resistance to chemical attack* Résistance à l'attaque chimique* - Beständigkeit gegen Chemikalien* Устойчивость к химическому воздействию* | ISO 10545-13 | Resistente - Resistant Résistante - Beständig - Стойкий |
| | Resistenza alle macchie* - Resistance to stains* Résistance aux taches* - Fleckenbeständigkeit* Устойчивость к образованию пятен* | ISO 10545-14 | Pulibile - Cleanable Nettoyable - Leicht zu reinigen Чистящийся |
| | Resistenza allo scivolamento** - Slip resistance** Résistance au glissement** - Rutschhemmende Eigenschaft** Сопротивление скольжению** | DIN 51130 - DIN 51097 ▲ ANSI A326.3 | R9 Matt Wet DCOF ≥ 0,42 |
| | Spessore nominale - Nominal Thickness Épaisseur nominale - Nominalstärke Номинальная толщина | | 9 mm |

* Valori medi riferiti agli ultimi due anni di produzione e relativi alla finitura naturale del prodotto - Average values referred to the last two years of production and related to the matt finish of the product - Valeurs moyennes des deux dernières années de production et relatifs à la finition naturelle du produit - Durchschnittswerte, die sich auf die letzten zwei Produktionsjahre beziehen und auf die matte Obaerfläche - Средние значения относятся к последним двум годам производства и натуральной отделке поверхности

** Valori relativi alla finitura naturale del prodotto ed a test effettuati da laboratori esterni accreditati, disponibili in azienda; ci rendiamo disponibili alla verifica dell'eventuale lotto interessato all'acquisto. - As far as values relating to the matt finish of the product and to tests carried out by certified external laboratories whose results are available upon request at Headoffice, we are willing to check the lot you are interested in purchasing. - Valeurs se référant à la finition naturelle du produit selon des tests effectués par des laboratoires extérieurs accrédités et à la disposition de toute personne intéressée auprès de nos bureaux; nous sommes disponibles pour le contrôle de l'éventuel lot concerné par l'achat. - Werte bezogen auf das natürliche Produktfinish und in anerkannten externen Labors geprüft, im Unternehmen erhältlich; für eventuelle Prüfungen der zu erwerbenden Warenposten stehen wir gern zur Verfügung. - Значения, касающиеся натуральных характеристик изделий и тестов, выполненных внешними авторизованными лабораториями, имеются в компании. Мы готовы выполнить проверку партии товара, которую намереваетесь приобрести.

• Per prodotti chimici di uso domestico e additivi per piscina. - For domestic chemicals and swimming pool additives. - Pour produits chimiques à usage domestique et additifs pour piscines. - Für chemische Produkte für den Hausgebrauch und Schwimmbadzusätze. - Для бытовых химикатов и добавок для бассейнов.

▲ Valori wet DCOF specifici disponibili in azienda - Wet DCOF specific values available at the company - Valeurs wet DCOF spécifiques disponibles à l'usine - Prüfwerte Wet DCOF stehen im Werk zur Verfügung - Показатели wet DCOF доступны при запросе

Le tonalità dei campioni sono da considerarsi puramente indicative. - Tones of samples are indicative. - Les tonalités des échantillons sont purement indicatives. - Die farbtöne der Muster sind als rein indicativ zu betrachten. - Тона образцов ориентировочные.

Built

Contemporary surfaces



Il grès porcellanato di BUILT è l'affermazione del cemento che trascende la sua funzione primaria di materiale edilizio, e si propone come rinnovata soluzione per le finiture d'interni. BUILT è espressione del contemporaneo.

BUILT is the interpretation of concrete beyond its main function as a building material. Cement has emerged as a new trend for interior surfaces as well as exterior spaces. BUILT is the expression of concrete in a contemporary style.

Le grès cérame de BUILT est l'affirmation du ciment qui transcende sa fonction primaire, celle de matériau de construction, et se propose comme une nouvelle solution pour les finitions d'intérieurs. BUILT est l'expression du modernisme.

Das Feinsteinzeug BUILT ist eine Hommage an den Zement, der über seine primäre Funktion als Baustoff hinausgeht und sich als immer wieder neue Lösung auch für den Innenausbau anbietet. BUILT ist Ausdruck des zeitgenössischen Stils par excellence.

Керамогранит коллекции BUILT утверждает цемент в качестве не просто строительного материала, а нового решения для отделки помещений. BUILT выражает дух современности.



Info
Resources
Tools



Wall: DAM COMPOSIZIONE M 30x30 MATT RT

Colori - Formati

Colors - Sizes

60x60 . 30x60 9 mm MATT RT
120x120 20 mm AEXTRA20 RT R11 B

DAM



PATH

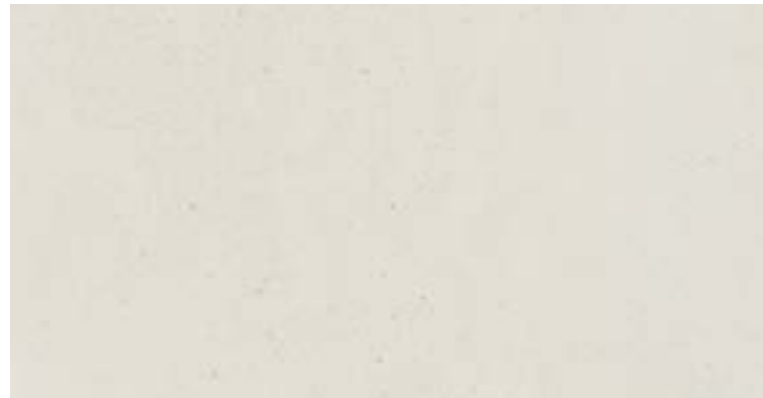

YARD



SIDEWALK



BLOCK



9 mm



60x60
23⁵/₈"x23⁵/₈"



30x60
11⁵/₈"x23⁵/₈"

MATT RT

20 mm



120x120
47²/₈"x47²/₈"

AEXTRA20 RT R11 B

*La liste a jour des produits et formats des series certifiees QB-UPEC est disponible en usine.

Built

La gamma

The range

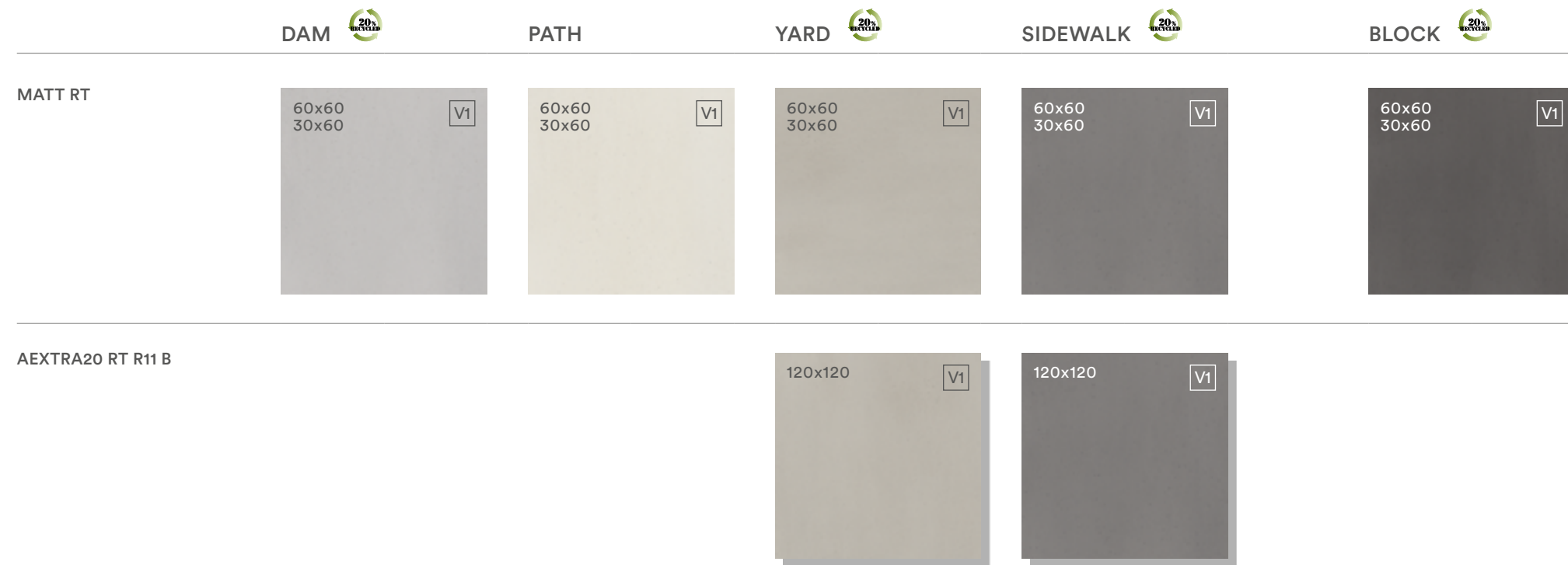

Decori

Decors

COMPOSIZIONE M 30x30 cm . 11¹⁵/₁₆"x11¹⁵/₁₆" MATT

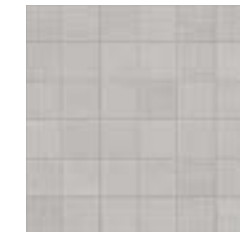

DAM

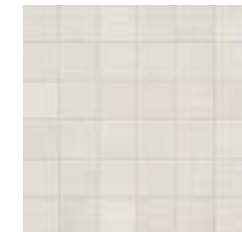

PATH



YARD

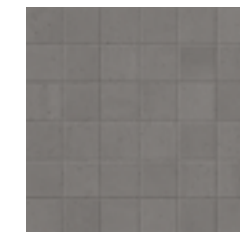



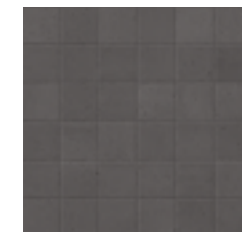



SIDEWALK



BLOCK



| | A E X T R A 2 0 | | |
|----------|------------------------------------------------------------------------------------------------------------------------------------------------------------------------------------------------|-------------------------------------------------------------------------------------------------------------------------------------------------------------------------------------------------|-----------------------------------------------------------------------------------------------------------------------------------------------------------------------------------------------------|
| |  60x60 cm 23 ⁵ / ₁₆ "x23 ⁵ / ₁₆ " 9 mm MATT RT |  30x60 cm 11 ¹³ / ₁₆ "x23 ⁵ / ₁₆ " 9 mm MATT RT |  120x120 cm 47 ² / ₁₆ "x47 ² / ₁₆ " 20 mm RT R11 B |
| Dam | ● | ● | ● |
| Path | ● | ● | ● |
| Yard | ● | ● | ● |
| Sidewalk | ● | ● | ● |
| Block | ● | ● | ● |

| |  Battiscopa - Bullnose Plinthe - Sockel Плинтус 7,2x60 cm 2 ¹⁵ / ₁₆ "x23 ⁵ / ₁₆ " MATT |  Scalino - Step tread Nez de marche - Stufe Cotto-Art Фронтальная ступень 33x60 cm 13"x23 ⁵ / ₁₆ " MATT |  Angolare - Step tread corner Pièce angulaire - Stufenecke Угловая ступень 33x33 cm 13"x13" MATT |
|----------|------------------------------------------------------------------------------------------------------------------------------------------------------------------------------------------------------------------------------------------------|-------------------------------------------------------------------------------------------------------------------------------------------------------------------------------------------------------------------------------------------|---------------------------------------------------------------------------------------------------------------------------------------------------------------------------------------------------------------|
| Dam | ● | ● | ● |
| Path | ● | ● | ● |
| Yard | ● | ● | ● |
| Sidewalk | ● | ● | ● |
| Block | ● | ● | ● |

| IMBALLI - PACKAGING - CONDITIONNEMENT - VERPACKUNGS-EINHEITEN - УПАКОВКА | | | | | | | | |
|--------------------------------------------------------------------------|----------------------------------------------------------------------|------------------------------------------|------|--------|---------------------------|-------|----------|--|
| Formato - Size - Format - Формат | | Scatola - Box - Boîte - Karton - Коробка | | | Pallet - Palette - Палета | | | |
| CM | INCHES | PZ | MQ | KG | SC | MQ | KG | |
| 60x60 | 23 ⁵ / ₁₆ "x23 ⁵ / ₁₆ " | 4 | 1,44 | ~28,40 | 30 | 43,20 | ~852,00 | |
| 30x60 | 11 ¹³ / ₁₆ "x23 ⁵ / ₁₆ " | 7 | 1,26 | ~25,00 | 40 | 50,40 | ~1000,00 | |
| 120x120 | 47 ² / ₁₆ "x47 ² / ₁₆ " | 1 | 1,44 | ~65,50 | 20 | 28,80 | ~1310,00 | |

RT Rettificato, quadrato, monocalibro. - Rectified, squared, one caliber. - Rectifié, mis d'equerre et monocalibre. - Rektifiziert, rechtwinkelig und Ein kaliber. - Ректифицированный, одного калибра.
 ** Disponibile solo su richiesta. - Manufactured only upon special request. - Seulement sur demande. - Nur auf Anfrage. - Производится только по заказу.















Si raccomanda l'utilizzo di una fuga di 2/3 mm al fine di semplificare le operazioni di posa e ottimizzare la naturalezza del risultato finale. - We recommend you a 2/3 mm grout joint to simplify the laying and optimize the naturalness of the final result. - Un joint de 2/3 mm est conseillé afin de simplifier les opérations de pose et optimiser l'effet naturel du résultat final. - Es wird empfohlen mit einer Fuge von 2/3 mm zu arbeiten, um am Ende den Verlegevorgang zu vereinfachen und die bestmögliche Natürlichkeit der Arbeit zu erzielen. - Для облегчения операций укладки и повышения натуральности вида конечного результата рекомендуется выполнять шов шириной 2-3 мм.

Al fine di facilitare la manutenzione ordinaria si raccomanda di effettuare un lavaggio acido dopo 48 ore dalla stuccatura con un acido specifico per grès porcellanato. - In order to favour the ordinary maintenance procedures, it is recommended to carry out an acid wash of the surface after 48 hours from grout filling using an acid agent specific for porcelain stoneware tiles. - Afin de faciliter l'entretien ordinaire de votre carrelage, nous vous conseillons de le laver 48 heures après le colmatage des joints, avec un acide spécifique pour grès cérame. - Um die Instandhaltung zu erleichtern, empfiehlt es sich 48 Stunden nach der Stuckatur mit einer sauren Lösung speziell für Feinsteinzeug zu waschen. - Чтобы упростить уход за плиткой, спустя 48 часов после затирки швов рекомендуется выполнить обработку кислотным продуктом, пригодным для керамогранита.

CARATTERISTICHE TECNICHE

TILE PERFORMANCE DATA - NOTES TECHNIQUES - TECHNISCHE AUSKÜNFTE - ТЕХНИЧЕСКАЯ ХАРАКТЕРИСТИКА

Classificazione secondo EN ISO 14411 ISO 13006 annesso G gruppo Bla con Ev ≤0,5% - Classification in accordance with EN ISO 14411 ISO 13006 annex G standards Bla with Ev ≤ 0,5% - Classification selon EN ISO 14411 ISO 13006 annexe G groupe Bla avec Ev ≤0,5% - Klassifizierung gemäß EN ISO 14411 ISO 13006 anlage G Gruppe Bla mit Ev ≤0,5% - Классификация в соответствии с EN ISO 14411 ISO 13006, приложение G, стандарт Bla, где Ev ≤0,5%

| | CARATTERISTICA TECNICA TECHNICAL CHARACTERISTIC CARACTERISTIQUE TECHNIQUE TECHNISCHE DATEN ТЕХНИЧЕСКАЯ ХАРАКТЕРИСТИКА | METODO DI PROVA TESTS METHOD METHODE D'ESSAI TESTMETHODE МЕТОД ИСПЫТАНИЯ | VALORE * MEDIO "CAESAR" AVERAGE "CAESAR" VALUE * VALEUR * MOYEN "CAESAR" "CAESAR" DURCHSCHNITTSWERT * СРЕДНЕЕ ЗНАЧЕНИЕ "CAESAR" * | VALORE * MEDIO "CAESAR" AVERAGE "CAESAR" VALUE A E X T R A 2 0 OPEN YOUR STYLE |
|---------------------------------------------------------------------------------------|-------------------------------------------------------------------------------------------------------------------------------------------------------------------------------------------------------------------------------------|--------------------------------------------------------------------------------------|-----------------------------------------------------------------------------------------------------------------------------------------------|--------------------------------------------------------------------------------------------------------------------------------------------------------------------------------------------------------------------------------------------------------------|
|  | Dimensione - Size Dimension - Abmessungen - Размер | ISO 10545-2 | Conforme - In accordance Conforme - Erfüllt - Соответствует | Conforme - In accordance Conforme - Erfüllt - Соответствует |
|  | Assorbimento d'acqua* - Water absorption* Absorption d'eau* - Wasseraufnahme* - % Поглощения воды* | ISO 10545-3 | ≤ 0,1% | ≤ 0,1% |
|  | Resistenza alla flessione* - Bending strength* Résistance à la flexion* - Biegezugfestigkeit* - Упругость* | ISO 10545-4 | Conforme - In accordance Conforme - Erfüllt - Соответствует | Non applicabile a piastrelle con una forza di rottura ≥ 3000 N Not applicable to tiles with a breaking strength ≥ 3000 N Nicht anwendbar bei Fliesen mit einer Bruchlast ≥ 3000 N Не применяется в отношении плиток с прочностью на разрыв ≥ 3000 N |
|  | Sforzo di rottura (S) - Breaking strength Charge de rupture - Bruchlast - Разрушающее усилие | ISO 10545-4 | Sps ≥ 7,5 mm S ≥ 1300 N | > 10.000 N |
|  | Resistenza all'urto - Impact resistance Résistance au choc - Schlagfestigkeit - Ударпрочность | ISO 10545-5 | ≥ 0,80 | - |
|  | Resistenza all'abrasione profonda* - Deep scratch resistance* Résistance à l'abrasion profonde* - Widerstand gegen Tiefenverschleiß* Устойчивость глубокому истиранию* | ISO 10545-6 | Conforme - In accordance Conforme - Erfüllt - Соответствует | Conforme - In accordance Conforme - Erfüllt - Соответствует |
|  | Coefficiente di dilatazione termica lineare* - Thermal linear expansion coefficient* Coefficient de dilatation thermique linéaire* - Koeffizient der linearen thermischen Dehnung* - Коэффициент линейного теплового расширения* | ISO 10545-8 | ≈ 7 (10 ⁻⁶ °C ⁻¹) | ≈ 7 (10 ⁻⁶ °C ⁻¹) |
|  | Resistenza agli sbalzi termici* - Thermal shock resistance* Résistance aux écarts de température* - Temperaturwechsel Beständigkeit* Устойчивость к температурному перепаду* | ISO 10545-9 | Conforme - In accordance Conforme - Erfüllt - Соответствует | Conforme - In accordance Conforme - Erfüllt - Соответствует |
|  | Dilatazione all'umidità* - Expansion in humidity* Dilatation à l'humidité* - Feuchtigkeitsausdehnung* Расширение в условиях влажности* | ISO 10545-10 | Conforme - In accordance Conforme - Erfüllt - Соответствует | Conforme - In accordance Conforme - Erfüllt - Соответствует |
|  | Resistenza al gelo* - Frost resistance* Résistance au gel* - Frostbeständigkeit* - Морозоустойчивость* | ISO 10545-12 | Resistente - Resistant Résistante - Beständig - Стойкий | Resistente - Resistant Résistante - Beständig - Стойкий |
|  | Resistenza all'attacco chimico* - Resistance to chemical attack* Résistance à l'attaque chimique* - Beständigkeit gegen Chemikalien* Устойчивость к химическому воздействию* | ISO 10545-13 | Resistente - Resistant Résistante - Beständig - Стойкий | Resistente - Resistant Résistante - Beständig - Стойкий |
|  | Resistenza alle macchie* - Resistance to stains* Résistance aux taches* - Fleckenbeständigkeit* Устойчивость к образованию пятен* | ISO 10545-14 | Pulibile - Cleanable Nettoyable - Leicht zu reinigen - Чистящийся | Pulibile - Cleanable Nettoyable - Leicht zu reinigen - Чистящийся |
|  | Resistenza allo scivolamento** - Slip resistance** Résistance au glissement** - Rutschhemmende Eigenschaft** Сопротивление скольжению** | DIN 51130 - DIN 51097 ▲ ANSI A326.3 | R10 A Matt Wet DCOF ≥ 0,42 | R11 B Wet DCOF ≥ 0,55 |
|  | Spessore nominale - Nominal Thickness Épaisseur nominale - Nominalstärke Номинальная толщина | | 9 mm | 20 mm |

* Valori medi riferiti agli ultimi due anni di produzione e relativi alla finitura naturale del prodotto - Average values referred to the last two years of production and related to the matt finish of the product - Valeurs moyennes des deux dernières années de production et relatifs à la finition naturelle du produit - Durchschnittswerte, die sich auf die letzten zwei Produktionsjahre beziehen und auf die matte Oberfläche - Средние значения относятся к последним двум годам производства и натуральной отделке поверхности

** Valori relativi alla finitura naturale del prodotto ed a test effettuati da laboratori esterni accreditati, disponibili in azienda; ci rendiamo disponibili alla verifica dell'eventuale lotto interessato all'acquisto. - As far as values relating to the matt finish of the product and to tests carried out by certified external laboratories whose results are available upon request at Headoffice, we are willing to check the lot you are interested in purchasing. - Valeurs se référant à la finition naturelle du produit selon des tests effectués par des laboratoires extérieurs accrédités et à la disposition de toute personne intéressée auprès de nos bureaux; nous sommes disponibles pour le contrôle de l'éventuel lot concerné par l'achat. - Werte bezogen auf das natürliche Produktfinish und in anerkannten externen Labors geprüft, im Unternehmen erhältlich; für eventuelle Prüfungen der zu erwerbenden Warenposten stehen wir gern zur Verfügung. - Значения, касающиеся натуральных характеристик изделий и тестов, выполненных внешними авторизованными лабораториями, имеются компании. Мы готовы выполнить проверку партии товара, которую намереваетесь приобрести.

• Per prodotti chimici di uso domestico e additivi per piscina. - For domestic chemicals and swimming pool additives. - Pour produits chimiques à usage domestique et additifs pour piscines. - Für chemische Produkte für den Hausgebrauch und Schwimmbadzusätze. - Для бытовых химикатов и добавок для бассейнов.

▲ Valori wet DCOF specifici disponibili in azienda - Wet DCOF specific values available at the company - Valeurs wet DCOF spécifiques disponibles à l'usine - Prüfwerte Wet DCOF stehen im Werk zur Verfügung - Показатели wet DCOF доступны при запросе

Le tonalità dei campioni sono da considerarsi puramente indicative. - Tones of samples are indicative. - Les tonalités des échantillons sont purement indicatives. Die Farbtöne der Muster sind als rein indicativ zu betrachten. - Тона образцов ориентировочные.

I.Mat

Industrial material



I materiali di origine industriale da sempre ispirano e caratterizzano il mondo del design e dell'architettura. I.MAT è l'acronimo di "industrial material", ovvero materiale industriale per eccellenza, per il look "industrial" unito alle performance del grès porcellanato Caesar. I.MAT traduce in grès porcellanato il fascino contemporaneo del cemento dando vita a un materiale che crea suggestioni di grande impatto visivo.

Industrially-sourced materials have always inspired and distinguished the world of design and architecture. I.MAT is the acronym of "industrial material", that is to say industrial material par excellence, to achieve that "industrial" look combined with the superior performance of Caesar porcelain tiles. I.MAT conveys the contemporary charm of concrete to porcelain tiles, giving life to a material that generates suggestions with a huge visual impact.

Les matériaux d'origine industrielle inspirent et caractérisent depuis toujours le monde du design et de l'architecture. I.MAT est l'acronyme de « industrial material », c'est-à-dire matériau industriel par excellence, pour son look industriel combiné aux performances du grès cérame Caesar. I.MAT traduit en grès cérame le charme contemporain du ciment donnant vie à un matériau qui crée des suggestions de grand impact visuel.

Industrielle Materialien haben seit jeher die Welt des Designs und der Architektur inspiriert. I.MAT steht für „industrial material“, das heißt für industrielles Material par excellence. Für einen „industriellen“ Look, der zugleich die ganzen Leistungen des Feinsteinzeugs von Caesar besitzt. I.MAT überträgt die faszinierend moderne Optik des Zements auf Feinsteinzeug. Damit entsteht ein Material von höchst effektvoller Ausstrahlung.

Материалы, позаимствованные из промышленного мира, всегда характеризовали мир дизайна и архитектуры и вдохновляли его представителей. I.MAT – это акроним словосочетания "industrial material", то есть промышленный материал высшего качества для создания интерьеров в индустриальном стиле с высокими техническими характеристиками керамогранита Caesar. I.MAT воплощает в керамограните современный шарм цемента, дающий жизнь материалу, позволяющему создавать эффектные композиции.



Info
Resources
Tools

CONCRETE LOOK



Floor: SQUARE 80x80 MATT RT R10 B
Wall: AXIOM RULE 33,5x35 MATT

Colori - Formati

Colors - Sizes

120x120 . 60x120 . 80x80 . 20x80 9 mm MATT RT R10 B

60x120 9 mm PATTERN MATT RT R10 B

80x80 20 mm AEXTRA20 RT R11 C

RATIO



AREA



RULE



SQUARE





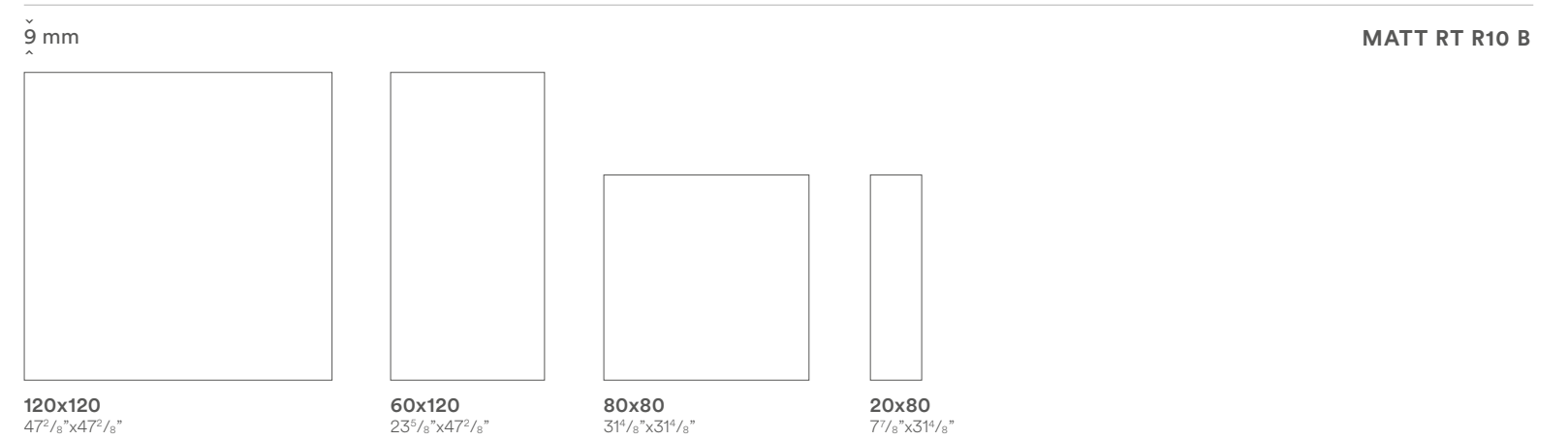

CUBE

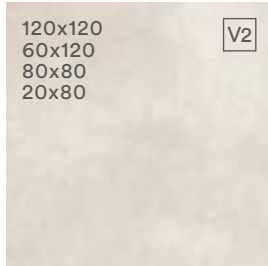
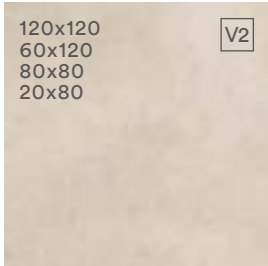
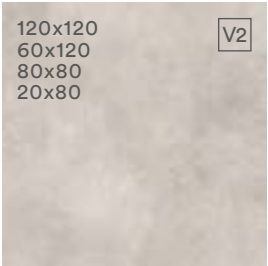
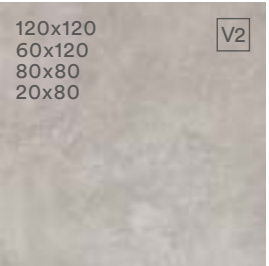
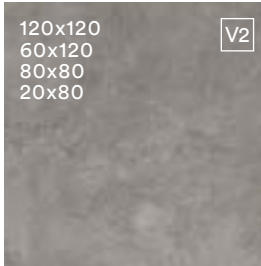
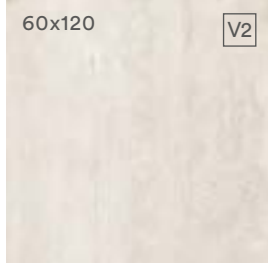

*La liste à jour des produits et formats des series certifiées QB-UPEC est disponible en usine.

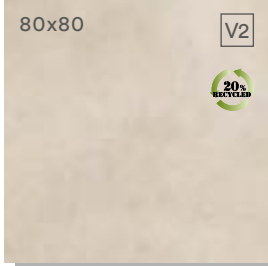
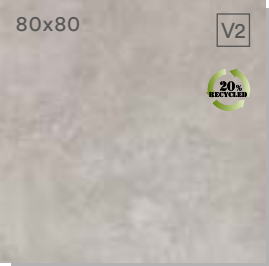
La gamma The range

| | RATIO | AREA | RULE | SQUARE | CUBE |
|-----------------------|---------------------------------------------------------------------------------------------------------------------------------|---------------------------------------------------------------------------------------------------------------------------------|----------------------------------------------------------------------------------------------------------------------------------|-----------------------------------------------------------------------------------------------------------------------------------|-----------------------------------------------------------------------------------------------------------------------------------|
| MATT RT R10 B |  <p>120x120 60x120 80x80 20x80</p> |  <p>120x120 60x120 80x80 20x80</p> |  <p>120x120 60x120 80x80 20x80</p> |  <p>120x120 60x120 80x80 20x80</p> |  <p>120x120 60x120 80x80 20x80</p> |
| PATTERN MATT RT R10 B |  <p>60x120</p> | |  <p>60x120</p> |  <p>60x120</p> | |
| AEXTRA20 RT R11 C | |  <p>80x80</p> | |  <p>80x80</p> |  <p>80x80</p> |

RT Rettificato, quadrato, monocalibro. - Rectified, squared, one caliber. - Rectifié, mis d'équerre et monocalibre. - Rektifiziert, rechteckig und Ein kaliber. - Ректифицированный, одного калибра.

Decori Decors

COMPOSIZIONE M 30x30 cm . 11³/₁₆"x11⁵/₁₆" MATT



RATIO

AREA

RULE



SQUARE

CUBE

AXIOM 33,5x35 cm . 13³/₁₆"x13⁶/₈" MATT



RATIO

AREA

RULE



SQUARE

CUBE



| | 120x120 cm 47 ⁵ / ₈ "x47 ⁵ / ₈ " 9 mm MATT RT R10 B | 60x120 cm 23 ⁵ / ₈ "x47 ⁵ / ₈ " 9 mm MATT RT R10 B | 60x120 cm 23 ⁵ / ₈ "x47 ⁵ / ₈ " 9 mm PATTERN MATT RT R10 B | 80x80 cm 31 ¹ / ₈ "x31 ¹ / ₈ " 9 mm MATT RT R10 B | 20x80 cm 7 ⁷ / ₈ "x31 ¹ / ₈ " 9 mm MATT RT R10 B | 80x80 cm 31 ¹ / ₈ "x31 ¹ / ₈ " 20 mm RT R11 C |
|--------|----------------------------------------------------------------------------------------------------------|---------------------------------------------------------------------------------------------------------|-----------------------------------------------------------------------------------------------------------------|--------------------------------------------------------------------------------------------------------|-------------------------------------------------------------------------------------------------------|----------------------------------------------------------------------------------------------------|
| Ratio | ● | ● | ● | ● | ● | ● |
| Area | ● | ● | ● | ● | ● | ● |
| Rule | ● | ● | ● | ● | ● | ● |
| Square | ● | ● | ● | ● | ● | ● |
| Cube | ● | ● | ● | ● | ● | ● |

| | 7,2x80 cm 2 ¹³ / ₁₆ "x31 ¹ / ₈ " MATT | 7,2x60 cm 2 ¹³ / ₁₆ "x23 ⁵ / ₈ " MATT | 33x80 cm 13"x31 ¹ / ₈ " MATT | 33x33 cm 13"x13" MATT |
|--------|-----------------------------------------------------------------------------------------|-----------------------------------------------------------------------------------------|----------------------------------------------------------|-----------------------------|
| Ratio | ● | ● | ● | ● |
| Area | ● | ● | ● | ● |
| Rule | ● | ● | ● | ● |
| Square | ● | ● | ● | ● |
| Cube | ● | ● | ● | ● |

| IMBALLI - PACKAGING - CONDITIONNEMENT - VERPACKUNGS-EINHEITEN - УПАКОВКА | | | | | | | |
|--------------------------------------------------------------------------|---------------------------------------------------------------------|------------------------------------------|--------|--------|---------------------------|--------|----------|
| Formato - Size - Format - Формат | | Scatola - Box - Boîte - Karton - Коробка | | | Pallet - Palette - Палета | | |
| CM | INCHES | PZ | MQ | KG | SC | MQ | KG |
| 120x120 | 47 ⁵ / ₈ "x47 ⁵ / ₈ " | 2 | 2,8561 | ~62,00 | 20 | 57,122 | ~1240,00 |
| 60x120 | 23 ⁵ / ₈ "x47 ⁵ / ₈ " | 2 | 1,44 | ~30,40 | 35 | 50,40 | ~1064,00 |
| 80x80 | 31 ¹ / ₈ "x31 ¹ / ₈ " | 2 | 1,28 | ~27,36 | 48 | 61,44 | ~1313,28 |
| 20x80 | 7 ⁷ / ₈ "x31 ¹ / ₈ " | 6 | 0,96 | ~20,52 | 32 | 30,72 | ~656,64 |
| 80x80 A E X T R A 2 0 | 47 ¹ / ₁₆ "x47 ¹ / ₁₆ " | 1 | 0,64 | ~29,70 | 42 | 26,88 | ~1247,40 |

RT Rettificato, squadrato, monocalibro. - Rectified, squared, one caliber. - Rectifié, mis d'equerre et monocalibre. - Rektifiziert, rechteckig und Ein kaliber. - Ректифицированный, одного калибра.

** Disponibile solo su richiesta. - Manufactured only upon special request. - Seulement sur demande. - Nur auf Anfrage. - Производится только по заказу.

Si raccomanda l'utilizzo di una fuga di 2/3 mm al fine di semplificare le operazioni di posa e ottimizzare la naturalezza del risultato finale. - We recommend you a 2/3 mm grout joint to simplify the laying and optimize the naturalness of the final result. - Un joint de 2/3 mm est conseillé afin de simplifier les opérations de pose et optimiser l'effet naturel du résultat final. - Es wird empfohlen mit einer Fuge von 2/3 mm zu arbeiten, um am Ende den Verlegvorgang zu vereinfachen und die bestmögliche Natürlichkeit der Arbeit zu erzielen. - Для облегчения операций укладки и повышения натуральности вида конечного результата рекомендуется выполнять шов шириной 2-3 мм.

Al fine di facilitare la manutenzione ordinaria si raccomanda di effettuare un lavaggio acido dopo 48 ore dalla stuccatura con un acido specifico per grès porcellanato. - In order to favour the ordinary maintenance procedures, it is recommended to carry out an acid wash of the surface after 48 hours from grout filling using an acid agent specific for porcelain stoneware tiles. - Afin de faciliter l'entretien ordinaire de votre carrelage, nous vous conseillons de le laver 48 heures après le colmatage des joints, avec un acide spécifique pour grès cérame. - Um die Instandhaltung zu erleichtern, empfiehlt es sich 48 Stunden nach der Stuckatur mit einer sauren Lösung speziell für Feinsteinzeug zu waschen. - Чтобы упростить уход за плиткой, спустя 48 часов после затирки швов рекомендуется выполнить обработку кислотным продуктом, пригодным для керамогранита.

CARATTERISTICHE TECNICHE

TILE PERFORMANCE DATA - NOTES TECHNIQUES - TECHNISCHE AUSKÜNFTE - ТЕХНИЧЕСКАЯ ХАРАКТЕРИСТИКА

Classificazione secondo EN ISO 14411 ISO 13006 annesso G gruppo Bla con Ev ≤0,5% - Classification in accordance with EN ISO 14411 ISO 13006 annex G standards Bla with Ev ≤ 0,5% - Classification selon EN ISO 14411 ISO 13006 annexe G groupe Bla avec Ev ≤0,5% - Klassifizierung gemäß EN ISO 14411 ISO 13006 anlage G Gruppe Bla mit Ev ≤0,5% - Классификация в соответствии с EN ISO 14411 ISO 13006, приложение G, стандарт Bla, где Ev ≤0,5%

| | CARATTERISTICA TECNICA TECHNICAL CHARACTERISTIC CARACTERISTIQUE TECHNIQUE TECHNISCHE DATEN ТЕХНИЧЕСКАЯ ХАРАКТЕРИСТИКА | METODO DI PROVA TESTS METHOD METHODE D'ESSAI TESTMETHODE МЕТОД ИСПЫТАНИЯ | VALORE * MEDIO "CAESAR" AVERAGE "CAESAR" VALUE* VALEUR * MOYEN "CAESAR" "CAESAR" DURCHSCHNITTSWERT* СРЕДНЕЕ ЗНАЧЕНИЕ "CAESAR"* | VALORE * MEDIO "CAESAR" AVERAGE "CAESAR" VALUE A E X T R A 2 0 OPEN YOUR STYLE |
|--|------------------------------------------------------------------------------------------------------------------------------------------------------------------------------------------------------------------------------------------|--------------------------------------------------------------------------------------|--------------------------------------------------------------------------------------------------------------------------------------------|----------------------------------------------------------------------------------------------------------------------------------------------------------------------------------------------------------------------------------------------------------------------------------------------------------------------------------------|
| | Dimensione - Size Dimension - Abmessungen - Размер | ISO 10545-2 | Conforme - In accordance Conforme - Erfüllt - Соответствует | Conforme - In accordance Conforme - Erfüllt - Соответствует |
| | Assorbimento d'acqua* - Water absorption* Absorption d'eau* - Wasseraufnahme* - % Поглощения воды* | ISO 10545-3 | ≤ 0,1% | ≤ 0,1% |
| | Resistenza alla flessione* - Bending strength* Résistance à la flexion* - Biegezugfestigkeit* - Упругость* | ISO 10545-4 | Conforme - In accordance Conforme - Erfüllt - Соответствует | Non applicabile a piastrelle con una forza di rottura Not applicable to tiles with a breaking strength N'est pas applicable aux carreaux avec une charge de rupture Nicht anwendbar bei Fliesen mit einer Bruchlast Не применяется в отношении плиток с прочности на изгиб ≥ 3000 N ≥ 3000 N ≥ 3000 N ≥ 3000 N |
| | Sforzo di rottura (S) - Breaking strength Charge de rupture - Bruchlast - Пасрушающее усилие | ISO 10545-4 | Sps ≥ 7,5 mm S ≥ 1300 N | > 10.000 N |
| | Resistenza all'abrasione profonda* - Deep scratch resistance* Résistance à l'abrasion profonde* - Widerstand gegen Tiefenverschleiß* Устойчивость глубокому истиранию* | ISO 10545-6 | Conforme - In accordance Conforme - Erfüllt - Соответствует | Conforme - In accordance Conforme - Erfüllt - Соответствует |
| | Coefficiente di dilatazione termica lineare* - Thermal linear expansion coefficient* Coefficient de dilatation thermique linéaire* - Koeffizient der linearen thermischen Dehnung* - Коэффициент линейного температурного расширения* | ISO 10545-8 | = 7 (10 ⁻⁶ °C ⁻¹) | = 7 (10 ⁻⁶ °C ⁻¹) |
| | Resistenza agli sbalzi termici* - Thermal shock resistance* Résistance aux écarts de température* - Temperaturwechsel Beständigkeit* - Устойчивость к тепловому перепаду* | ISO 10545-9 | Resistente - Resistant Résistante - Beständig - Стойкий | Resistente - Resistant Résistante - Beständig - Стойкий |
| | Dilatazione all'umidità* - Expansion in humidity* Dilatation à l'humidité* - Feuchtigkeitsausdehnung* Расширение в условиях влажности* | ISO 10545-10 | ≤ 0,1 (mm/m) | ≤ 0,1 (mm/m) |
| | Resistenza al gelo* - Frost resistance* Résistance au gel* - Frostbeständigkeit* - Морозоустойчивость* | ISO 10545-12 | Resistente - Resistant Résistante - Beständig - Стойкий | Resistente - Resistant Résistante - Beständig - Стойкий |
| | Resistenza all'attacco chimico* - Resistance to chemical attack* Résistance à l'attaque chimique* - Beständigkeit gegen Chemikalien* Устойчивость к химическому воздействию* | ISO 10545-13 | Resistente - Resistant Résistante - Beständig - Стойкий | Resistente - Resistant Résistante - Beständig - Стойкий |
| | Carico statico - Static load Charge statique - Statische Last Статическая нагрузка | EN 12825 | - | 80x80 Centro - Centre - Au centre - Mitte - По центру KN>7,0 Centro lato - Side centre - Au centre latéralement Mitte Seite - По центру грани KN>5,0 Diagonale - Diagonal - En diagonale Diagonal - По диагонали KN>8,0 |
| | Resistenza alle macchie* - Resistance to stains* Résistance aux taches* - Fleckenbeständigkeit* Устойчивость к образованию пятен* | ISO 10545-14 | Pulibile - Cleanable Nettoyable - Leicht zu reinigen Чистящийся | Pulibile - Cleanable Nettoyable - Leicht zu reinigen Чистящийся |
| | Resistenza allo scivolamento** - Slip resistance** Résistance au glissement** - Rutschhemmende Eigenschaft** Сопrotivление скольжению** | DIN 51130 - DIN 51097 ▲ ANSI A326.3 | R10 B Matt Wet DCOF ≥ 0,42 | R11 C Wet DCOF ≥ 0,55 |
| | Spessore nominale - Nominal Thickness Épaisseur nominal - Nominalstärke Номинальная толщина | | 9 mm | 20 mm |

* Valori medi riferiti agli ultimi due anni di produzione e relativi alla finitura naturale del prodotto - Average values referred to the last two years of production and related to the matt finish of the product - Valeurs moyennes des deux dernières années de production et relatifs à la finition naturelle du produit - Durchschnittswerte, die sich auf die letzten zwei Produktionsjahre beziehen und auf die matte Oberfläche - Средние значения относятся к последним двум годам производства и натуральной отделке поверхности

** Valori relativi alla finitura naturale del prodotto ed a test effettuati da laboratori esterni accreditati, disponibili in azienda; ci rendiamo disponibili alla verifica dell'eventuale lotto interessato all'acquisto. - As far as values relating to the matt finish of the product and to tests carried out by certified external laboratories whose results are available upon request at Headoffice, we are willing to check the lot you are interested in purchasing. - Valeurs se référant à la finition naturelle du produit selon des tests effectués par des laboratoires extérieurs accrédités et à la disposition de toute personne intéressée auprès de nos bureaux; nous sommes disponibles pour le contrôle de l'éventuel lot concerné par l'achat. - Werte bezogen auf das natürliche Produktfinish und in anerkannten externen Labors geprüft, im Unternehmen erhältlich; für eventuelle Prüfungen der zu erwerbenden Warenposten stehen wir gern zur Verfügung. - Значения, касающиеся натуральных характеристик изделий и тестов, выполненных внешними авторизованными лабораториями, имеются в компании. Мы готовы выполнить проверку партии товара, которую намереваетесь приобрести.

• Per prodotti chimici di uso domestico e additivi per piscina. - For domestic chemicals and swimming pool additives. - Pour produits chimiques à usage domestique et additifs pour piscines. - Für chemische Produkte für den Hausgebrauch und Schwimmbadzusätze. - Для бытовых химикатов и добавок для бассейнов.

▲ Valori wet DCOF specifici disponibili in azienda - Wet DCOF specific values available at the company - Valeurs wet DCOF spécifiques disponibles à l'usine - Prüfwerte Wet DCOF stehen im Werk zur Verfügung - Показатели wet DCOF доступны при запросе

Le tonalità dei campioni sono da considerarsi puramente indicative. - Tones of samples are indicative. - Les tonalités des échantillons sont purement indicatives. Die farbtöne der Muster sind als rein indicativ zu betrachten. - Тона образцов ориентировочные.

Join

Suits you better

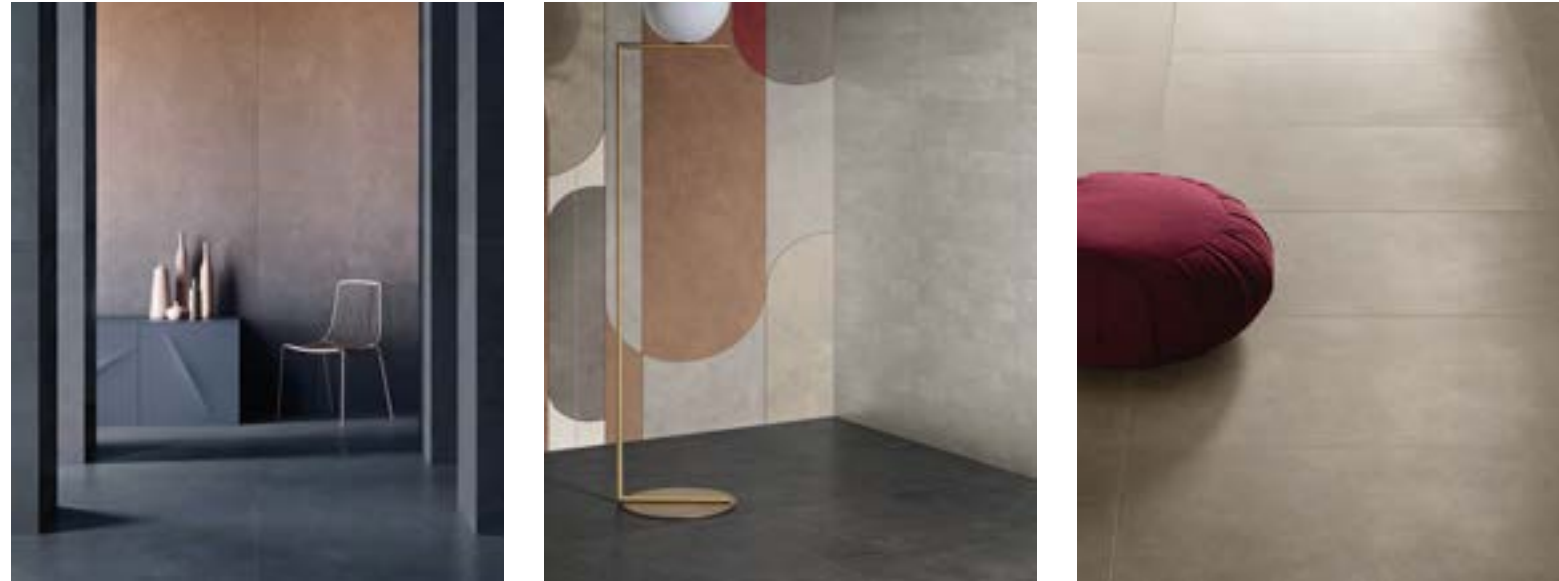

L'idea progettuale è di unire la modernità del cemento e l'eleganza della resina all'interno dello stesso prodotto. Nasce una collezione di grès porcellanato di prezioso valore materico, morbida nelle superfici e versatile nell'utilizzo.

The design idea is to combine the modernity of cement with the elegance of resin in one product. Here is a collection of premium-quality porcelain. Smooth surfaces and versatile use.

L'idée du projet est de marier la modernité du ciment et l'élégance de la résine au sein du même produit. C'est ainsi qu'est née cette collection de grès cérame, une matière précieuse pour des surfaces souples et une utilisation polyvalente.

Dem Projekt liegt die Idee zugrunde, die Modernität des Zements und die Eleganz von Harz in einem einzigen Produkt zu vereinen. Daraus ist eine edle Feinsteinzeugkollektion von hohem stofflichem Wert entstanden - mit weichen Oberflächen und großer Anwendungsvielfalt.

Идея проекта заключается в том, чтобы соединить новизну цемента и элегантность смол в одном продукте. В результате появилась коллекция керамогранита с благородной фактурой, мягкая на ощупь и подходящая для самых разных задач.



Info
Resources
Tools



Floor: **PLUME** 60x60 SOFT RT
Wall: **WING** 120x278 MATT RT, **VERVE** 30x60 SOFT RT, **VERVE DECO** 120x278 MATT RT
Furniture by CLOS: **ANIMA EVER** Apuan Gold Silk

Colori - Formati

Colors - Sizes

JOIN

120x278 6 mm MATT RT
 120x120 . 60x120 . 80x80 . 60x60 . 30x60 . 11,7x60 9 mm MATT RT R10 B
 120x120 . 60x120 . 80x80 . 60x60 . 30x60 . 11,7x60 9 mm SOFT RT
 60x60 20 mm AEXTRA20 RT R11 C

EASY JOIN

30x60 8 mm MATT NR R10 B

GLARE

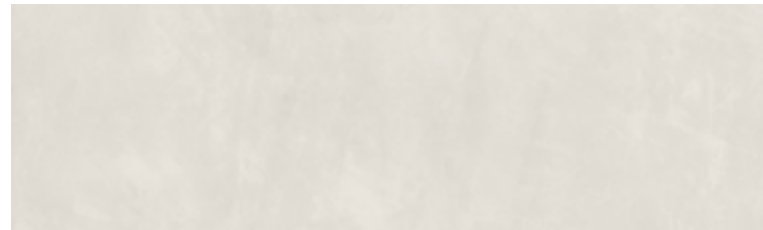

CANDLE



WING

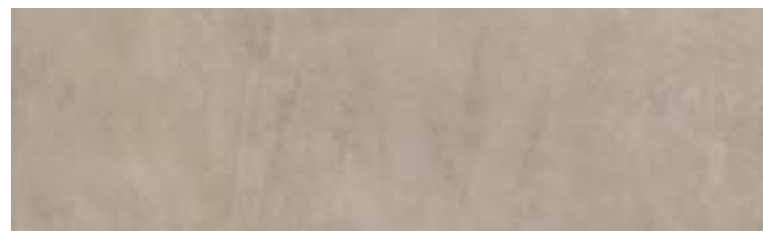

LEVITY



MANOR



PLUME

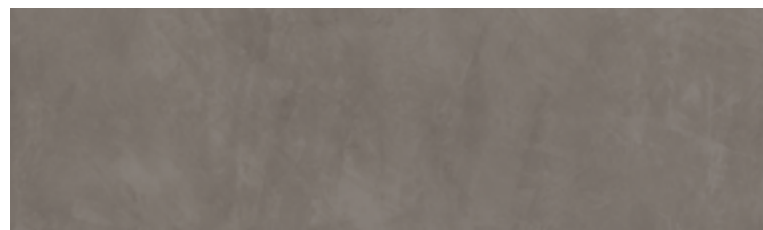

CHIMNEY



SPICE



VERVE

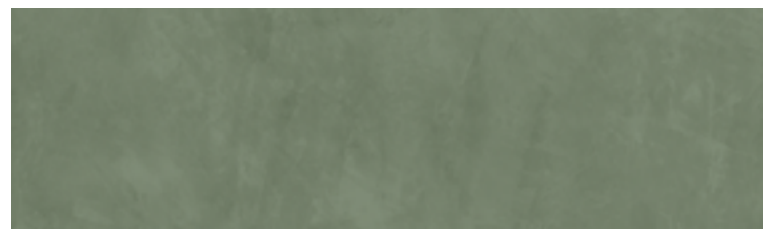

INK



6 mm

MATT RT

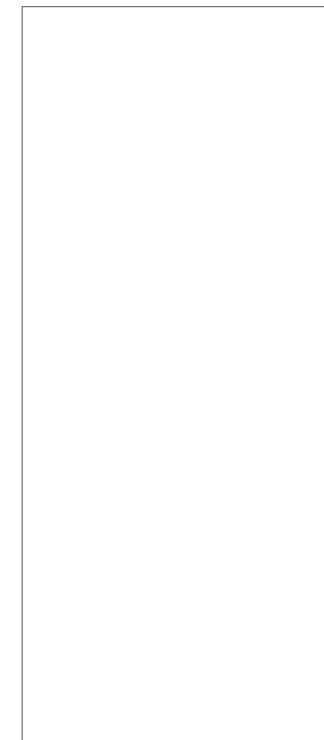

120x278
 47²/₈"x109⁷/₁₆"

9 mm

MATT RT R10 B
 SOFT RT

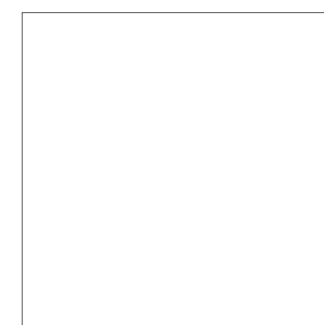

120x120
 47²/₈"x47²/₈"



60x120
 23⁵/₈"x47²/₈"

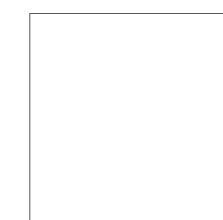

80x80
 31¹/₈"x31¹/₈"

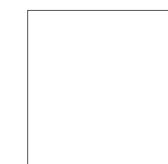

60x60
 23⁵/₈"x23⁵/₈"

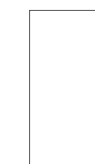

30x60
 11¹⁵/₁₆"x23⁵/₈"



11,7x60
 4⁵/₈"x23⁵/₈"

20 mm

AEXTRA20 RT R11 C

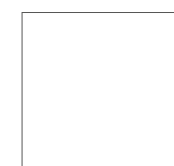

60x60
 23⁵/₈"x23⁵/₈"

8 mm



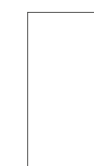









EASY JOIN MATT NR R10 B

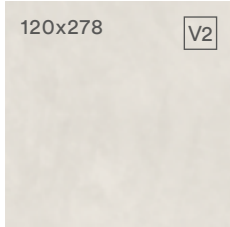

30x60
 11¹⁵/₁₆"x23⁵/₈"

La gamma

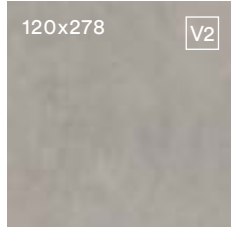
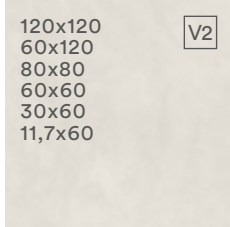
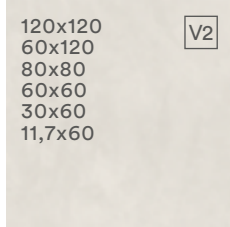
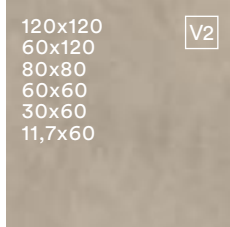
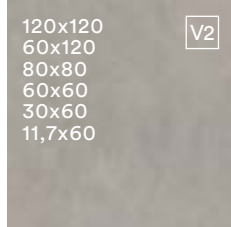
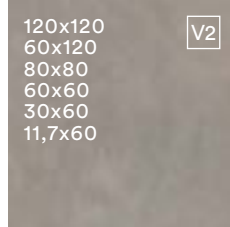
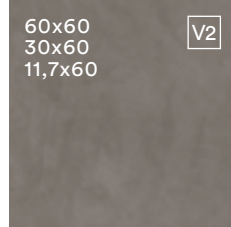
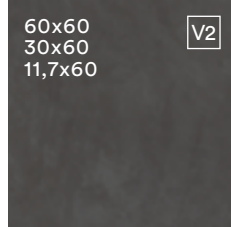
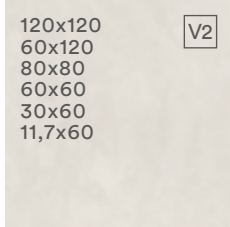
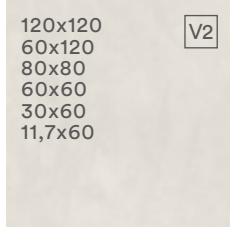
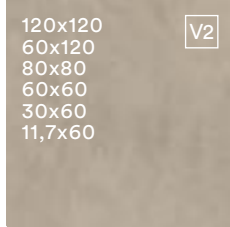
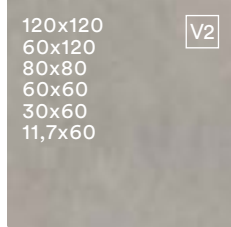
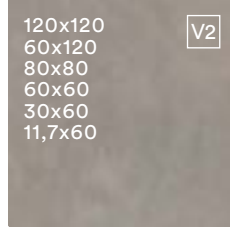
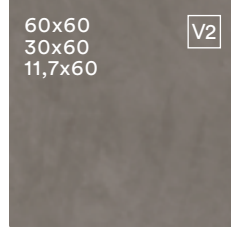
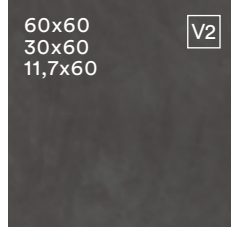
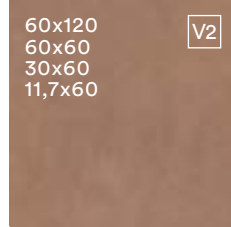
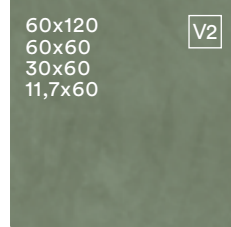
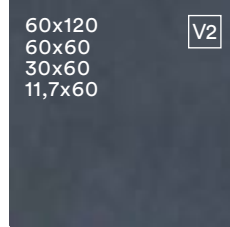
The range

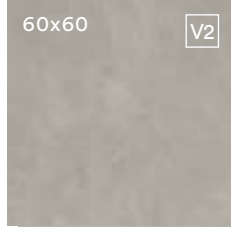
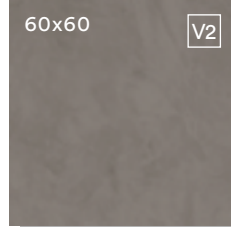
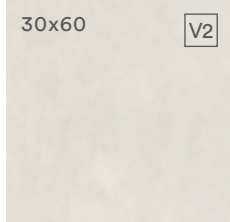
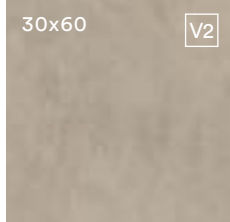
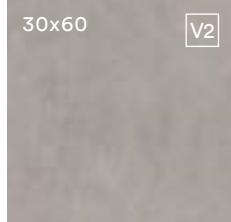
| | GLARE | CANDLE | WING  | LEVITY  | MANOR  | PLUME  | CHIMNEY  | SPICE  | VERVE  | INK  |
|--------------------------|-------------------------------------------------------------------------------------|-------------------------------------------------------------------------------------|------------------------------------------------------------------------------------------|--------------------------------------------------------------------------------------------|-------------------------------------------------------------------------------------------|-------------------------------------------------------------------------------------------|---------------------------------------------------------------------------------------------|-------------------------------------------------------------------------------------------|-------------------------------------------------------------------------------------------|-----------------------------------------------------------------------------------------|
| JOIN | | | | | | | | | | |
| MATT RT |  | |  |  | | | | | | |
| MATT RT R10 B |  |  |  |  |  |  |  | | | |
| SOFT RT |  |  |  |  |  |  |  |  |  |  |
| AEXTRA20 RT R11 C | | |  |  | |  | | | | |
| EASY JOIN | | | | | | | | | | |
| MATT NR R10 B | |  |  |  | | | | | | |

RT Rettificato, squadrato, monocalibro. - Rectified, squared, one caliber. - Rectifié, mis d'équerre et monocalibre. - Rektifiziert, rechtwinkelig und Ein kaliber. - Ректифицированный, одного калибра.
 NR Non rettificato. - Not rectified. - Non rectifié. - Nicht rektifiziert. - Не ретифицированный.

Decori

Decors

DECO 120x278 cm . 47²/₈"x109⁷/₁₆" MATT RT *



SPICE



VERVE

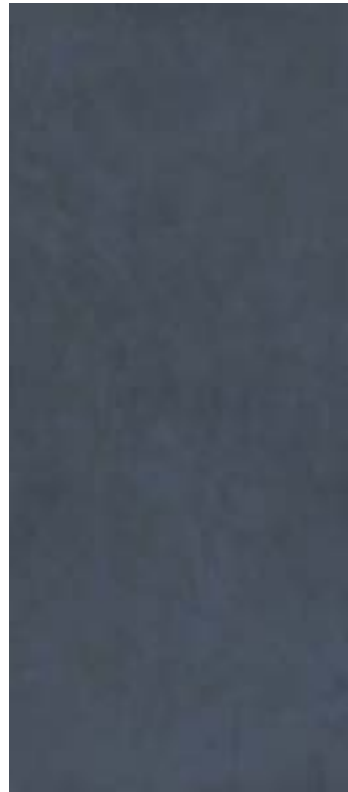

INK

* Solo per rivestimento. - Only for wall application. - Exclusivement pour revêtement mural. - Nur als Wandverkleidung geeignet. - Только для облицовки.

DUSK 120x278 cm . 47²/₈"x109⁷/₁₆" MATT RT *

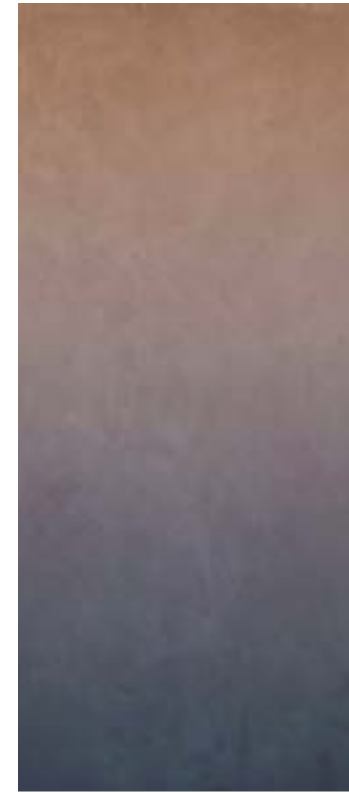

SPICE



VERVE

REED 120x278 cm . 47²/₈"x109⁷/₁₆" MATT RT *



I decori di Join in formato 120x278 sono realizzati tramite particolari applicazioni sulla superficie, successive alla cottura. Per la pulizia ordinaria, Caesar sconsiglia l'utilizzo di prodotti abrasivi, che potrebbero danneggiare la superficie; per evitare opacizzazioni o graffiature, si consiglia di eseguire la pulizia con un panno morbido e prodotti a PH neutro. In fase di posa del materiale, Caesar sconsiglia l'utilizzo di sistemi meccanici livellanti, che potrebbero causare danni alla superficie quando vengono rimossi. Prima di stuccare, si consiglia di proteggere la superficie nelle parti vicino al bordo con nastro adesivo per mascheratura; si raccomanda di utilizzare stucchi a base cementizia e non epossidica. Subito dopo la stuccatura rimuovere gli eventuali residui con acqua e un panno morbido, senza l'utilizzo di spugne abrasive.

The 120x278 cm decors of the Join collection were created using special surface applications after baking. For ordinary cleaning, Caesar advises to avoid abrasive products that could damage the surface. Cleaning with a soft cloth and neutral PH products is recommended to avoid dulling or scratching. When laying the material, Caesar recommends not to use mechanical levelling systems, which could cause damage to the surface when removed. Before grouting, it is advised to protect the surface in the parts near the edge with masking tape. Cement-based, not epoxy-based, grouts must be used. Immediately after grouting, remove any residues with water and a soft cloth, without using abrasive sponges.

Les décors de Join en format 120x278 ont été réalisées grâce à des applications spéciales sur la surface, successives à la cuisson. Pour l'entretien ordinaire, Caesar déconseille d'utiliser des produits abrasifs, qui pourraient endommager la surface. Afin d'éviter opacification et rayures, il est conseillé d'effectuer le nettoyage à l'aide d'un chiffon souple et de produits au pH neutre. Lors de la pose du matériau, Caesar déconseille d'utiliser des systèmes mécaniques de nivellement, qui pourraient causer des dommages sur la surface lorsqu'on les retire. Avant le jointoiment, il est conseillé de protéger la surface aux endroits proches du bord à l'aide de ruban adhésif de masquage, et il est recommandé d'utiliser un mortier à base de ciment et non époxy. Tout de suite après le jointoiment, retirer les éventuels restes avec de l'eau et un chiffon souple, sans utiliser d'éponge abrasive.

Die Dekore im Format 120x278 cm aus der Serie Join entstehen mit besonderen Applikationen nach dem Brennvorgang. Für die normale Reinigung rät Caesar von Scheuermitteln ab, da diese die Oberfläche beschädigen könnten. Um matte Stellen und Kratzer zu vermeiden, sollten zur Reinigung nur weiche Tücher und Produkte mit neutralem pH-Wert verwendet werden. Bei der Verlegung des Materials rät Caesar von mechanischen Nivelliermitteln ab, da die Oberfläche bei ihrer Entfernung Schaden nehmen könnte. Vor dem Verfugen sollte die Oberfläche an den Kanten abgeklebt werden; wir empfehlen zementhaltige Fugenmörtel und keine Epoxidharz-Fugenmassen. Eventuelle Rückstände sind sofort nach dem Verfugen mit einem trockenen Tuch und Wasser zu entfernen. Keine Scheuerschwämme verwenden.

Декоры коллекции Join в формате 120x278 реализованы, после обжига, методом специального поверхностного нанесения. Компания Caesar рекомендует не использовать абразивные чистящие средства во избежание повреждения поверхности. Для предотвращения помутнения или появления царапин рекомендуется проводить очистку чистой ветошью и нейтральными моющими средствами. При укладке плитки компания Caesar не рекомендует использовать механические выравнивающие приспособления, способные повредить поверхность. Перед затиркой швов рекомендуется защитить края плитки малярным скотчем. Рекомендуется использовать затирочные составы на цементной, а не эпоксидной основе. После затирки швов необходимо удалить остатки материала мягкой ветошью и водой, не применяя абразивные губки.

HOOP 120x278 cm . 47²/₈"x109⁷/₁₆" MATT RT *



A



B

RT Rettificato, squadrato, monocalibro. - Rectified, squared, one caliber. - Rectifié, mis d'équerre et monocalibre. - Rektifiziert, rechteckig und Ein kaliber. - Ректифицированный, одного калибра.

Materica

Design e tradizione



Dal calore del cotto, unito ai colori neutri del cemento, nasce una collezione in grès porcellanato dalla doppia anima che regala stili e abbinamenti tutti da scoprire. Inclusioni, imperfezioni e accenti cromatici caratterizzano Materica, connotandola di artigianalità e unicità, con richiami di colore caldi e moderni ad evocare suggestioni metropolitane. Uno stile inedito per vestire gli spazi dell'architettura e del vivere quotidiano.

The warmth of cotto, combined with the neutral colours of concrete, makes for a porcelain tile collection with two souls. Discover the many styles and combinations. Materica is about inclusions, imperfections and colour accents, all of which give it a unique, artisan aesthetic while the warm and modern colours offer an urban feel. A brand new style for spaces, whether architectural or the everyday.

La chaleur de la terre cuite, associée aux couleurs neutres du ciment, donne naissance à un grès cérame à l'âme double, qui offre des styles et des assortiments à couper le souffle. Les inclusions, imperfections et accents chromatiques qui caractérisent Materica lui donnent un aspect artisanal et unique, en évoquant des couleurs chaudes et modernes d'inspiration métropolitaine. Un style inédit pour revêtir les espaces de l'architecture et de la vie quotidienne.

Aus der Wärme des Cottos und neutralen Zementfarben entsteht eine Feinsteinzeugkollektion, in der zwei Seelen wohnen. Und deren Stilmerkmale und Kombinationsmöglichkeiten es zu entdecken lohnt. Einschlüsse, Unvollkommenheiten und Farbakzente prägen Materica und verleihen ihr einen handwerklichen und einzigartigen Charakter, mit Verweisen auf warme und moderne Farben sowie auf Großstadtmotive. Ein ungewöhnlicher Stil, der architektonische Räume kleidet und einen zeitgemäßen Lebensstil vertritt.

Из тепла, излучаемого «котто» в сочетании с нейтральными цветами цемента, рождается коллекция из керамогранита с двойной душой, дарящая стиль и сочетания, которые Вы обязательно должны увидеть. Включения, неоднородность и цветовые акценты – вот характерные черты коллекции Materica, которую можно описать в двух словах: дань традициям и уникальность, с отсылкой на теплые и современные цвета, напоминающие стиль мегаполиса. Уникальный стиль для оформления архитектурных пространств, в которых Вы будете жить.



Info
Resources
Tools



Floor: BIANCO 120x120 MATT RT R10 B
Wall: TERRA 22,5x45,3 cm SOFT NR, JOIN WING 120x278 MATT RT
Furniture by CLOS: ANIMA NERO ATLANTE 60x120 LUCIDATO RT

Colori - Formati

Colors - Sizes

120x120 . 60x120 . 80x80 . 40x80 9 mm MATT RT R10 B

22,5x45,3 9 mm SOFT NR

22,5x45,3 9 mm GRIP NR R11 C

80x80 20 mm AEXTRA20 RT R11 C

ANTRACITE



POLVERE



GRIGIO



BIANCO



CORDA



TERRA

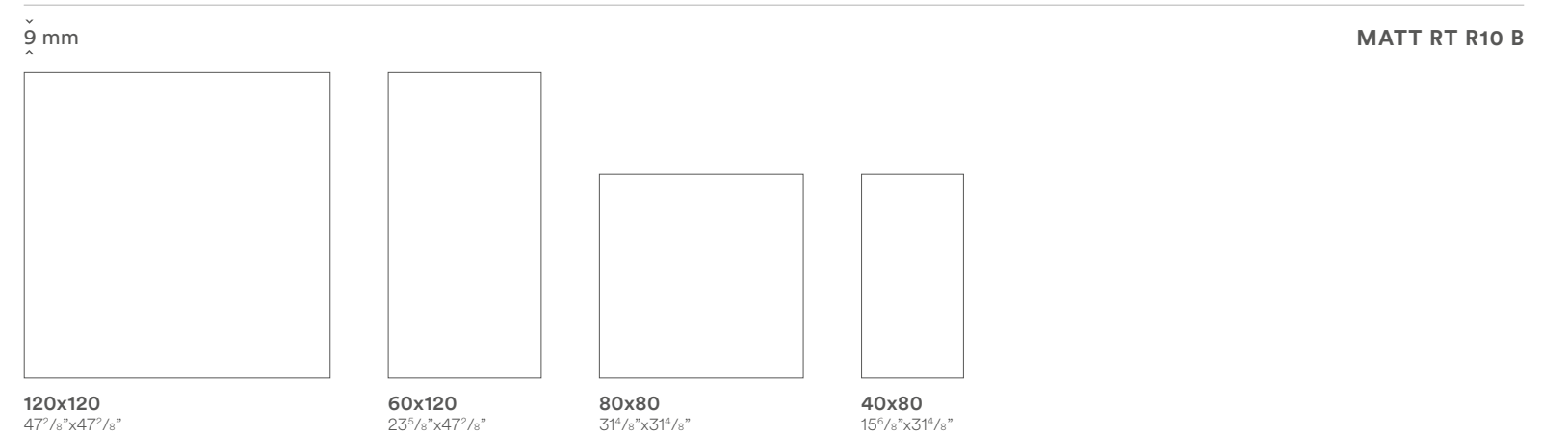

Materica

CONCRETE LOOK

La gamma

The range

ANTRACITE 

POLVERE 

GRIGIO

BIANCO

CORDA

TERRA

MATT RT R10 B

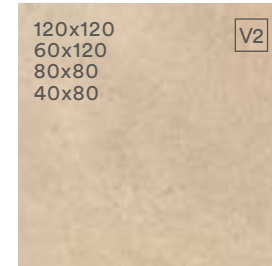
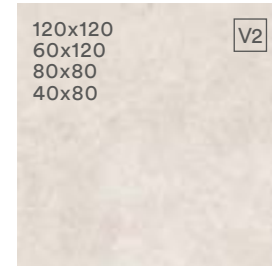
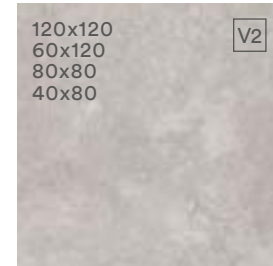

SOFT NR

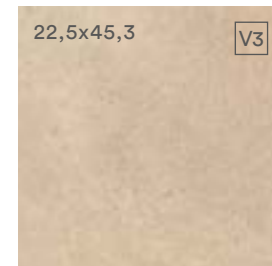
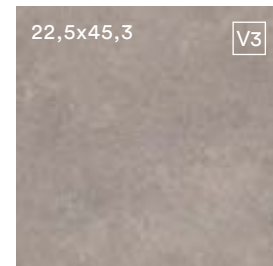

GRIP NR R11 C

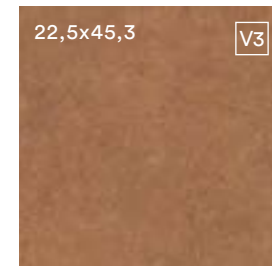
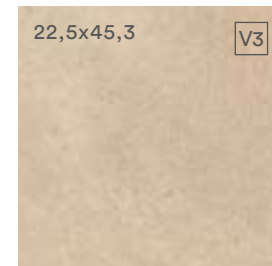
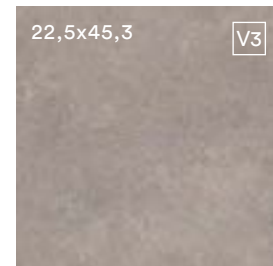

AEXTRA20 RT R11 C



RT Rettificato, squadrato, monocalibro. - Rectified, squared, one caliber. - Rectifié, mis d'équerre et monocalibre. - Rektifiziert, rechtwinkelig und Ein kaliber. - Ректифицированный, одного калибра.
NR Non rettificato. - Not rectified. - Non rectifié. - Nicht rektifiziert. - Не ретицированный.

Materica

CONCRETE LOOK

Decori

Decors

STILE 22,2x37 cm . 8⁶/₈"x14⁹/₁₆" MATT



Il decoro Stile crea interessanti trame decorative in combinazione con gli stucchi prescelti . The Stile decoration creates interesting decorative textures in combination with the chosen grouts . Le décor Style crée des trames décoratives intéressantes en combinaison avec les joints choisis . Das Dekor Stile schafft interessante dekorative Muster in Kombination mit dem entsprechenden Fugenmaterial . Декор Stile создает интересные узоры в сочетании с выбранным типом затирки



Stucco tono su tono. - Matching grout. - Joints ton sur ton. - Fugenmaterial Ton in Ton. - Затирка в тон.



Stucco a contrasto. - Contrasting grout. - Joints à contraste. - Fugenmaterial im Kontrast. - Контрастная затирка.

CARATTERISTICHE TECNICHE

TILE PERFORMANCE DATA - NOTES TECHNIQUES - TECHNISCHE AUSKÜNFTE - ТЕХНИЧЕСКАЯ ХАРАКТЕРИСТИКА

Classificazione secondo EN ISO 14411 ISO 13006 annesso G gruppo Bla con Ev ≤0,5% - Classification in accordance with EN ISO 14411 ISO 13006 annex G standards Bla with Ev ≤ 0,5% - Classification selon EN ISO 14411 ISO 13006 annexe G groupe Bla avec Ev ≤0,5% - Klassifizierung gemäß EN ISO 14411 ISO 13006 anlage G Gruppe Bla mit Ev ≤0,5% - Классификация в соответствии с EN ISO 14411 ISO 13006, приложение G, стандарт Bla, где Ev ≤0,5%

| | 120x120 cm 47 ² / ₈ "x47 ² / ₈ " 9 mm | | 60x120 cm 23 ⁵ / ₈ "x47 ² / ₈ " 9 mm | | 80x80 cm 31 ¹ / ₈ "x31 ¹ / ₈ " 9 mm | | 40x80 cm 15 ⁵ / ₈ "x31 ¹ / ₈ " 9 mm | | 22,5x45,3 cm 8 ¹³ / ₁₆ "x17 ¹³ / ₁₆ " 9 mm | | 80x80 cm 31 ¹ / ₈ "x31 ¹ / ₈ " 20 mm | |
|-----------|-----------------------------------------------------------------------------------------|---|----------------------------------------------------------------------------------------|---|---------------------------------------------------------------------------------------|---|---------------------------------------------------------------------------------------|---|----------------------------------------------------------------------------------------------|---|----------------------------------------------------------------------------------------|---|
| | MATT RT R10 B | | MATT RT R10 B | | MATT RT R10 B | | MATT RT R10 B | | SOFT NR | | GRIP NR R11 C | |
| Antracite | ● | ● | ● | ● | ● | ● | ● | ● | ● | ● | ● | ● |
| Polvere | ● | ● | ● | ● | ● | ● | ● | ● | ● | ● | ● | ● |
| Grigio | ● | ● | ● | ● | ● | ● | ● | ● | ● | ● | ● | ● |
| Bianco | ● | ● | ● | ● | ● | ● | ● | ● | ● | ● | ● | ● |
| Corda | ● | ● | ● | ● | ● | ● | ● | ● | ● | ● | ● | ● |
| Terra | ● | ● | ● | ● | ● | ● | ● | ● | ● | ● | ● | ● |

A E X T R A 2 0

| | 7,2x80 cm 2 ¹³ / ₁₆ "x31 ¹ / ₈ " MATT | | 33x120 cm 13"x47 ² / ₈ " MATT | | 33x33 cm 13"x13" MATT | | 15x30 cm 5 ⁷ / ₈ "x11 ¹³ / ₁₆ " GRIP | |
|-----------|-----------------------------------------------------------------------------------------|---|--------------------------------------------------------------------------------|---|---------------------------------------------------------------------------------|---|----------------------------------------------------------------------------------------|---|
| | Battiscopa - Bullnose Plinthe - Sockel Плинтус | | Scalino - Step tread Nez de marche - Stufe Cotto-Art Фронтальная ступень | | Angolare - Step tread corner Pièce angulaire - Stufenecke Угловая ступень | | Elemento L - Rounded coving Nez de marche - "L" Schenkel Элемент L | |
| Antracite | ● | ● | ● | ● | ● | ● | ● | ● |
| Polvere | ● | ● | ● | ● | ● | ● | ● | ● |
| Grigio | ● | ● | ● | ● | ● | ● | ● | ● |
| Bianco | ● | ● | ● | ● | ● | ● | ● | ● |
| Corda | ● | ● | ● | ● | ● | ● | ● | ● |
| Terra | ● | ● | ● | ● | ● | ● | ● | ● |

IMBALLI - PACKAGING - CONDITIONNEMENT - VERPACKUNGS-EINHEITEN - УПАКОВКА

| Formato - Size - Format - Формат | | Scatola - Box - Boîte - Karton - Коробка | | | Pallet - Palette - Палета | | |
|----------------------------------|----------------------------------------------------------------------|------------------------------------------|--------|--------|---------------------------|---------|----------|
| CM | INCHES | PZ | MQ | KG | SC | MQ | KG |
| 120x120 | 47 ² / ₈ "x47 ² / ₈ " | 2 | 2,856 | -62,00 | 20 | 57,12 | -1240,00 |
| 60x120 | 23 ⁵ / ₈ "x47 ² / ₈ " | 2 | 1,44 | -30,40 | 35 | 50,40 | -1064,00 |
| 80x80 | 31 ¹ / ₈ "x31 ¹ / ₈ " | 2 | 1,28 | -27,36 | 48 | 61,44 | -1313,28 |
| 40x80 | 15 ⁵ / ₈ "x31 ¹ / ₈ " | 4 | 1,28 | -24,90 | 28 | 35,84 | -697,20 |
| 22,5x45,3 | 8 ¹³ / ₁₆ "x17 ¹³ / ₁₆ " | 12 | 1,2231 | -23,70 | 34 | 41,5854 | -805,80 |
| 80x80 A E X T R A 2 0 | 31 ¹ / ₈ "x31 ¹ / ₈ " | 1 | 0,64 | -29,70 | 42 | 26,88 | -1247,40 |

RT Rettificato, squadrato, monocalibro. - Rectifié, mis d'équerre et monocalibre. - Rektifiziert, rechtwinkling und Ein kaliber. - Ректифицированный, одного калибра.

NR Non rettificato. - Not rectified. - Non rectifié. - Nicht rektifiziert. - Не ретицированный.

**** Disponibile solo su richiesta.** - Manufactured only upon special request. - Seulement sur demande. - Nur auf Anfrage. - Производится только по заказу.

Si raccomanda l'utilizzo di una fuga di 2/3 mm al fine di semplificare le operazioni di posa e ottimizzare la naturalezza del risultato finale. - We recommend you a 2/3 mm grout joint to simplify the laying and optimize the naturalness of the final result. - Un joint de 2/3 mm est conseillé afin de simplifier les opérations de pose et optimiser l'effet naturel du résultat final. - Es wird empfohlen mit einer Fuge von 2/3 mm zu arbeiten, um am Ende den Verlegevorgang zu vereinfachen und die bestmögliche Natürlichkeit der Arbeit zu erzielen. - Для облегчения операций укладки и повышения натуральности вида конечного результата рекомендуется выполнять шов шириной 2-3 мм.

Al fine di facilitare la manutenzione ordinaria si raccomanda di effettuare un lavaggio acido dopo 48 ore dalla stuccatura con un acido specifico per grès porcellanato. - In order to favour the ordinary maintenance procedures, it is recommended to carry out an acid wash of the surface after 48 hours from grout filling using an acid agent specific for porcelain stoneware tiles. - Afin de faciliter l'entretien ordinaire de votre carrelage, nous vous conseillons de le laver 48 heures après le colmatage des joints, avec un acide spécifique pour grès cérame. - Um die Instandhaltung zu erleichtern, empfiehlt es sich 48 Stunden nach der Stuckatur mit einer sauren Lösung speziell für Feinsteinzeug zu waschen. - Чтобы упростить уход за плиткой, спустя 48 часов после затирки швов рекомендуется выполнить обработку кислотным продуктом, пригодным для керамогранита.

| | CARATTERISTICA TECNICA TECHNICAL CHARACTERISTIC CARACTERISTIQUE TECHNIQUE TECHNISCHE DATEN ТЕХНИЧЕСКАЯ ХАРАКТЕРИСТИКА | METODO DI PROVA TESTS METHOD METHODE D'ESSAI TESTMETHODE МЕТОД ИСПЫТАНИЯ | VALORE * MEDIO "CAESAR" AVERAGE "CAESAR" VALUE* VALEUR * MOYEN "CAESAR" "CAESAR" DURCHSCHNITTSWERT* СРЕДНЕЕ ЗНАЧЕНИЕ "CAESAR"* | VALORE * MEDIO "CAESAR" AVERAGE "CAESAR" VALUE A E X T R A 2 0 OPEN YOUR STYLE |
|--|-------------------------------------------------------------------------------------------------------------------------------------------------------------------------------------------------------------------------------------|--------------------------------------------------------------------------------------|--------------------------------------------------------------------------------------------------------------------------------------------|-----------------------------------------------------------------------------------------------------------------------------------------------------------------------------------------------------------------------------------------------------------------------------------------|
| | Dimensione - Size Dimension - Abmessungen - Размер | ISO 10545-2 | Conforme - In accordance Conforme - Erfüllt - Соответствует | Conforme - In accordance Conforme - Erfüllt - Соответствует |
| | Assorbimento d'acqua* - Water absorption* Absorption d'eau* - Wasseraufnahme* - % Поглощения воды* | ISO 10545-3 | ≤ 0,1% | ≤ 0,1% |
| | Resistenza alla flessione* - Bending strength* Résistance à la flexion* - Biegezugfestigkeit* - Упругость* | ISO 10545-4 | Conforme - In accordance Conforme - Erfüllt - Соответствует | Non applicabile a piastrelle con una forza di rottura Not applicable to tiles with a breaking strength N'est pas applicable aux carreaux avec une charge de rupture Nicht anwendbar bei Fliesen mit einer Bruchlast Не применяется в отношении плиток с прочностью на изрыв |
| | Sforzo di rottura (S) - Breaking strength Charge de rupture - Bruchlast - Разрушающее усилие | ISO 10545-4 | Sps ≥ 7,5 mm S ≥ 1300 N | > 10.000 N |
| | Resistenza all'abrasione profonda* - Deep scratch resistance* Résistance à l'abrasion profonde* - Widerstand gegen Tiefenverschleiß* Устойчивость глубокому истиранию* | ISO 10545-6 | Conforme - In accordance Conforme - Erfüllt - Соответствует | Conforme - In accordance Conforme - Erfüllt - Соответствует |
| | Coefficiente di dilatazione termica lineare* - Thermal linear expansion coefficient* Coefficient de dilatation thermique linéaire* - Koeffizient der linearen thermischen Dehnung* - Коэффициент линейного теплового расширения* | ISO 10545-8 | = 7 (10 ⁻⁶ °C ⁻¹) | = 7 (10 ⁻⁶ °C ⁻¹) |
| | Resistenza agli sbalzi termici* - Thermal shock resistance* Résistance aux écarts de température* - Temperaturwechsel Beständigkeit* Устойчивость к тепловому перепаду* | ISO 10545-9 | Resistente - Resistant Résistante - Beständig - Стойкий | Resistente - Resistant Résistante - Beständig - Стойкий |
| | Dilatazione all'umidità* - Expansion in humidity* Dilatation à l'humidité* - Feuchtigkeitsausdehnung* Расширение в условиях влажности* | ISO 10545-10 | ≤ 0,1 (mm/m) | ≤ 0,1 (mm/m) |
| | Resistenza al gelo* - Frost resistance* Résistance au gel* - Frostbeständigkeit* - Морозостойчивость* | ISO 10545-12 | Resistente - Resistant Résistante - Beständig - Стойкий | Resistente - Resistant Résistante - Beständig - Стойкий |
| | Resistenza all'attacco chimico* - Resistance to chemical attack* Résistance à l'attaque chimique* - Beständigkeit gegen Chemikalien* Устойчивость к химическому воздействию* | ISO 10545-13 | Resistente - Resistant Résistante - Beständig - Стойкий | Resistente - Resistant Résistante - Beständig - Стойкий |
| | Carico statico - Static load Charge statique - Statische Last Статическая нагрузка | EN 12825 | - | 80x80 Centro - Centre - Au centre - Mitte - По центру Centro lato - Side centre - Au centre latéralement Mitte Seite - По центру грани Diagonale - Diagonal - En diagonale Diagonal - По диагонали |
| | Resistenza alle macchie* - Resistance to stains* Résistance aux taches* - Fleckenbeständigkeit* Устойчивость к образованию пятен* | ISO 10545-14 | Pulibile - Cleanable Nettoyable - Leicht zu reinigen Чистящийся | Pulibile - Cleanable Nettoyable - Leicht zu reinigen Чистящийся |
| | Resistenza allo scivolamento** - Slip resistance** Résistance au glissement** - Rutschhemmende Eigenschaft** Сопротивление скольжению** | DIN 51130 - DIN 51097 ▲ ANSI A326.3 | R10 B Matt - Soft R11 C Grip Wet DCOF ≥ 0,42 Wet DCOF ≥ 0,42 Wet DCOF ≥ 0,55 | R11 C Wet DCOF ≥ 0,55 |
| | Spessore nominale - Nominal Thickness Epaisseur nominal - Nominalstärke Номинальная толщина | | 9 mm | 20 mm |

* Valori medi riferiti agli ultimi due anni di produzione e relativi alla finitura naturale del prodotto - Average values referred to the last two years of production and related to the matt finish of the product - Valeurs moyennes des deux dernières années de production et relatifs à la finition naturelle du produit - Durchschnittswerte, die sich auf die letzten zwei Produktionsjahre beziehen und auf die matte Oberfläche - Средние значения относятся к последним двум годам производства и натуральной отделке поверхности

** Valori relativi alla finitura naturale del prodotto ed a test effettuati da laboratori esterni accreditati, disponibili in azienda; ci rendiamo disponibili alla verifica dell'eventuale lotto interessato all'acquisto. - As far as values relating to the matt finish of the product and to tests carried out by certified external laboratories whose results are available upon request at Headoffice, we are willing to check the lot you are interested in purchasing. - Valeurs se référant à la finition naturelle du produit selon des tests effectués par des laboratoires extérieurs accrédités et à la disposition de toute personne intéressée auprès de nos bureaux; nous sommes disponibles pour le contrôle de l'éventuel lot concerné par l'achat. - Werte bezogen auf das natürliche Produktfinish und in anerkannten externen Labors geprüft, im Unternehmen erhältlich; für eventuelle Prüfungen der zu erwerbenden Warenposten stehen wir gern zur Verfügung. - Значения, касающиеся натуральных характеристик изделий и тестов, выполненных внешними авторизованными лабораториями, имеются в компании. Мы готовы выполнить проверку партии товара, которую намереваетесь приобрести.

• Per prodotti chimici di uso domestico e additivi per piscina. - For domestic chemicals and swimming pool additives. - Pour produits chimiques à usage domestique et additifs pour piscines. - Für chemische Produkte für den Hausgebrauch und Schwimmbadzusätze. - Для бытовых химикатов и добавок для бассейнов.

▲ Valore minimo richiesto ANSI A137.1 - 2012 > 0,42. - Minimum Value Required ANSI A137.1 - 2012 > 0,42. - Valeur Minimum Demandée ANSI A137.1 - 2012 > 0,42. - Erforderlicher Mindestwert ANSI A137.1 - 2012 > 0,42. - Минимальное требуемое значение по ANSI A137.1-2012 >0,42.

▲ Valori wet DCOF specifici disponibili in azienda - Wet DCOF specific values available at the company - Valeurs wet DCOF spécifiques disponibles à l'usine - Prüfwerte Wet DCOF stehen im Werk zur Verfügung - Показатели wet DCOF доступны при запросе

Le tonalità dei campioni sono da considerarsi puramente indicative. - Tones of samples are indicative. - Les tonalités des échantillons sont purement indicatives. Die farbtöne der Muster sind als rein indicativ zu betrachten. - Тона образцов ориентировочные.

Prima

Design comes first



Prima è un richiamo all'essenzialità dell'argilla, rivisitata con un accattivante accento contemporaneo. Una materia pensata per progettare ambienti dal comfort istintivo, e al tempo stesso attuale.

Prima is a reminder of the essentiality of clay, revisited with an appealing contemporary accent. A material conceived to design environments with an instinctive, yet contemporary comfort.

Prima est une évocation du caractère essentiel de l'argile, revisitée en y apportant un accent contemporain plein de charme. Une matière pensée pour concevoir des espaces au confort instinctif et actuel.

Prima verweist auf das ursprüngliche Wesen des Tons und besitzt zugleich eine attraktive, kontemporäre Ausstrahlung. Ein Material für Räume, in denen man sich spontan wohlfühlt. Und das zugleich absolut aktuell ist.

В первую очередь речь идет о притягательной простоте глины, переосмысленной с привлекательным современным акцентом. Это материал, предназначенный для проектирования пространств с актуальным стилем, вызывающих инстинктивное ощущение комфорта.



Info
Resources
Tools



CONCRETE LOOK

Floor: **LEAD** 60x120 MATT RT R10 B
Wall: **CONCRETE** 120x278 MATT RT, **GOLD WILLOW** 120x278 MATT RT, **SIENNA** 60x120 SOFT RT, **SIENNA COMP. Q** 29x29 SOFT
Furniture by CLOS: **CONCRETE** 120x278 MATT RT

Colori - Formati

Colors - Sizes

120x278 6 mm MATT RT
 60x120 . 80x80 . 60x60 . 30x60 9 mm MATT RT R10 B
 120x120 . 60x120 9 mm SOFT RT
 80x80 . 60x60 20 mm AEXTRA20 RT R11 C

CHALK



ECRU



CONCRETE



CLAY



LEAD



POWDER



SIENNA



AVIO

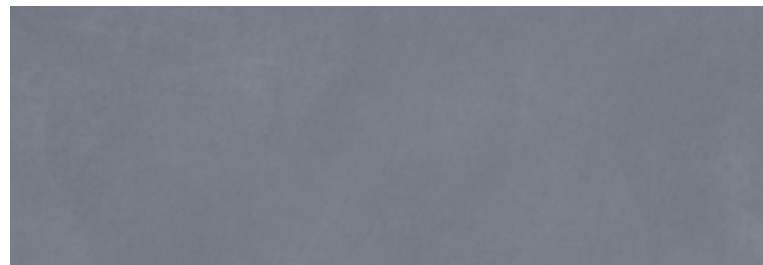

6 mm

MATT RT



120x278
 47²/₈"x109⁷/₁₆"

9 mm

MATT RT R10 B



60x120
 23⁵/₈"x47²/₈"

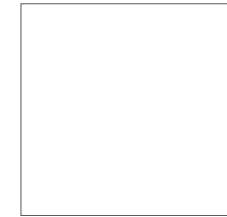

80x80
 31¹/₈"x31¹/₈"



60x60
 23⁵/₈"x23⁵/₈"



30x60
 11¹³/₁₆"x23⁵/₈"

9 mm

SOFT RT



120x120
 47²/₈"x47²/₈"



60x120
 23⁵/₈"x47²/₈"

20 mm

AEXTRA20 RT R11 C



80x80
 31¹/₈"x31¹/₈"

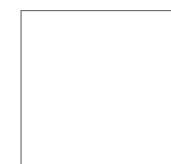

60x60
 23⁵/₈"x23⁵/₈"

La gamma

The range

CHALK

ECRU

CONCRETE



CLAY



LEAD



POWDER



SIENNA



AVIO



MATT RT

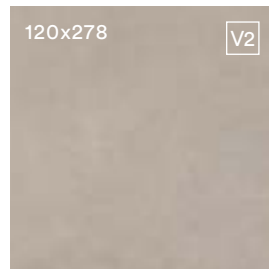

MATT RT R10 B

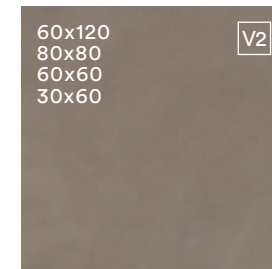
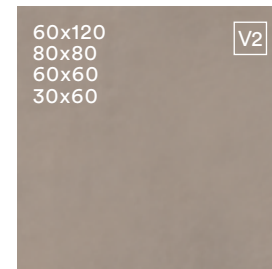
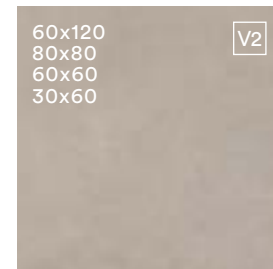
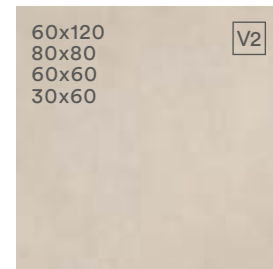
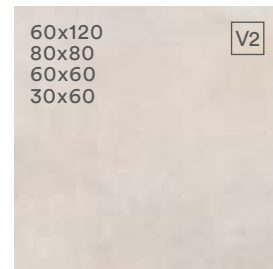

SOFT RT

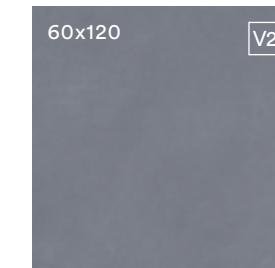
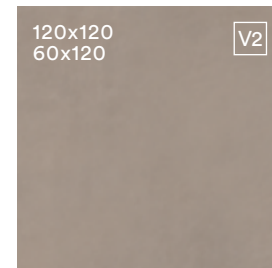
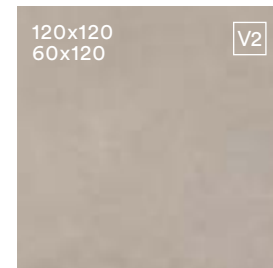
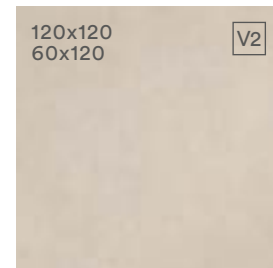
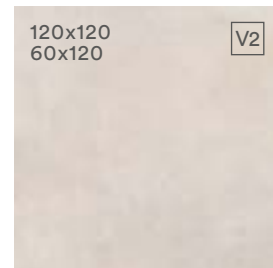

AEXTRA20 RT R11 C

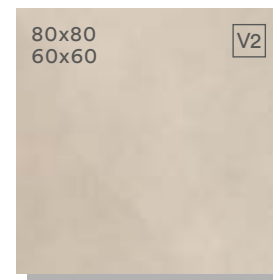

Decori

Decors

RAMMED 120x278 cm . 47²/₈"x109⁷/₁₆" MATT RT

Range faces



IMPRESSION 120x278 cm . 47²/₈"x109⁷/₁₆" MATT RT

Range faces



Realizzato su **Prima** - Ecrú.
Made on **Prima** - Ecrú.
Fabriqué sur **Prima** - Ecrú.
Realisiert bei **Prima** - Ecrú.
Реализовано на основе **Prima** - Ecrú.

GOLD WILLOW 120x278 cm . 47²/₈"x109⁷/₁₆" MATT RT *

Range faces



A

B

Realizzato su **Prima** - Concrete.
Made on **Prima** - Concrete.
Fabriqué sur **Prima** - Concrete.
Realisiert bei **Prima** - Concrete.
Реализовано на основе **Prima** - Concrete.

* Solo per rivestimento. - Only for wall application. - Exclusivement pour revêtement mural. - Nur als Wandverkleidung geeignet. - Только для облицовки.

I decori Gold Willow in formato 120x278 sono realizzati tramite particolari applicazioni sulla superficie, successive alla cottura. Per la pulizia ordinaria, Caesar sconsiglia l'utilizzo di prodotti abrasivi, che potrebbero danneggiare la superficie; per evitare opacizzazioni o graffiature, si consiglia di eseguire la pulizia con un panno morbido e detergenti a PH neutro. In fase di posa del materiale, Caesar sconsiglia l'utilizzo di sistemi meccanici livellanti, che potrebbero causare danni alla superficie quando vengono rimossi. Prima di stuccare, si consiglia di proteggere la superficie nelle parti vicino al bordo con nastro adesivo per mascheratura; si raccomanda di utilizzare stucchi a base cementizia e non epossidica. Subito dopo la stuccatura, rimuovere gli eventuali residui con acqua e un panno morbido, senza l'utilizzo di spugne abrasive.

The 120x278 cm Gold Willow decors were created using special surface applications after baking. For ordinary cleaning, Caesar advises to avoid abrasive products that could damage the surface. Cleaning with a soft cloth and neutral PH products is recommended to avoid dulling or scratching. When laying the material, Caesar recommends not to use mechanical levelling systems, which could cause damage to the surface when removed. Before grouting, it is advised to protect the surface in the parts near the edge with masking tape. Cementbased, not epoxy-based, grouts must be used. Immediately after grouting, remove any residues with water and a soft cloth, without using abrasive sponges.

Les décors Gold Willow en format 120x278 ont été réalisées grâce à des applications spéciales sur la surface, successives à la cuisson. Pour l'entretien ordinaire, Caesar déconseille d'utiliser des produits abrasifs, qui pourraient endommager la surface. Afin d'éviter opacification et rayures, il est conseillé d'effectuer le nettoyage à l'aide d'un chiffon souple et de produits au pH neutre. Lors de la pose du matériau, Caesar déconseille d'utiliser des systèmes mécaniques de nivellement, qui pourraient causer des dommages sur la surface lorsqu'on les retire. Avant le jointoiement, il est conseillé de protéger la surface aux endroits proches du bord à l'aide de ruban adhésif de masquage, et il est recommandé d'utiliser un mortier à base de ciment et non époxy. Tout de suite après le jointoiement, retirer les éventuels restes avec de l'eau et un chiffon souple, sans utiliser d'éponge abrasive.

Die Dekore Gold Willow im Format 120x278 entstehen mit besonderen Applikationen nach dem Brennvorgang. Für die normale Reinigung rät Caesar von Scheuermitteln ab, da diese die Oberfläche beschädigen könnten. Um matte Stellen und Kratzer zu vermeiden, sollten zur Reinigung nur weiche Tücher und Produkte mit neutralem pH-Wert verwendet werden. Bei der Verlegung des Materials rät Caesar von mechanischen Nivelliermitteln ab, da die Oberfläche bei ihrer Entfernung Schaden nehmen könnte. Vor dem Verfugen sollte die Oberfläche an den Kanten abgeklebt werden; wir empfehlen zementhaltige Fugenmörtel und keine Epoxidharz-Fugenmassen. Eventuelle Rückstände sind sofort nach dem Verfugen mit einem trockenen Tuch und Wasser zu entfernen. Keine Scheuerschwämme verwenden.

Декоры коллекции Gold Willow в формате 120x278 реализованы, после обжига, методом специального поверхностного нанесения. Компания Caesar рекомендует не использовать абразивные чистящие средства во избежание повреждения поверхности. Для предотвращения помутнения или появления царапин рекомендуется проводить очистку чистой ветошью и нейтральными моющими средствами. При укладке плитки компания Caesar не рекомендует использовать механические выравнивающие приспособления, способные повредить поверхность. Перед затиркой швов рекомендуется защитить края плитки малярным скотчем. Рекомендуется использовать затирочные составы на цементной, а не эпоксидной основе. После затирки швов необходимо удалить остатки материала мягкой ветошью и водой, не применяя абразивные губки.

Le lastre potrebbero presentare minimi disallineamenti tra le grafiche in continuità: ciò è da intendersi come caratteristica intrinseca del prodotto.

There may be minor misalignments of continuous graphics: this is to be considered as an intrinsic feature of the product.

Die Platten könnten untereinander minimale Abweichungen in der Ausrichtung des graphischen Designs aufweisen: dies ist als ein charakteristisches Merkmal des Produktes zu betrachten.

Les dalles peuvent présenter de faibles écarts de graphiques en continuité: ceci est une caractéristique intrinsèque du produit.

У плит может наблюдаться минимальная нестыковка сплошного рисунка, которая должна считаться особенностью изделия.

RT Rettificato, quadrato, monocalibro. - Rectified, squared, one caliber. - Rectifié, mis d'équerre et monocalibre. - Rektifiziert, rechtwinkelig und Ein kaliber. - Ректифицированный, одного калибра.

I decori 120x278 Gold sono realizzati tramite applicazione da terzo fuoco di inchiostri a base oro. - The 120x278 Gold decorations are produced by third-firing application of gold-based inks. - Les décors 120x278 Gold sont réalisés par application au troisième feu d'encre à base d'or. - Die Dekore 120x278 Gold werden durch Auftragen von Golddruckfarben im Drittbrand hergestellt. - Декоры 120x278 Gold производятся методом третьего обжига с применением красок на золотой базе.

Decori

Decors

COMPOSIZIONE Q 29x29 cm . 11⁷/₁₆"x11⁷/₁₆" MATT R10 B



CHALK



ECRU

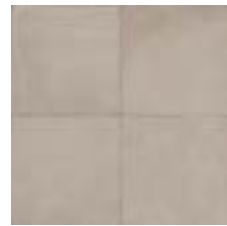

CONCRETE



CLAY



LEAD

COMPOSIZIONE S 29x29 cm . 11⁷/₁₆"x11⁷/₁₆" SOFT



CHALK



ECRU



CONCRETE



CLAY

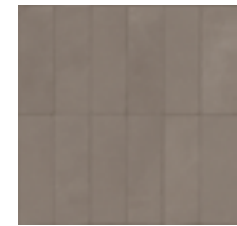

LEAD

COMPOSIZIONE Q 29x29 cm . 11⁷/₁₆"x11⁷/₁₆" SOFT

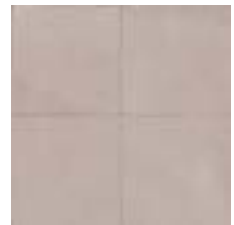

POWDER

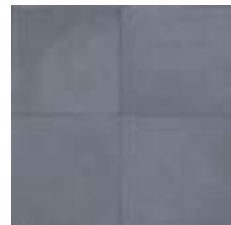

AVIO

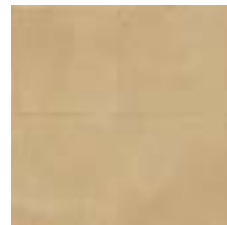

SIENNA

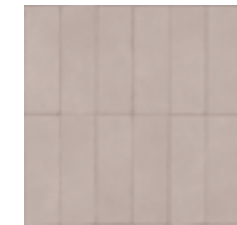

POWDER

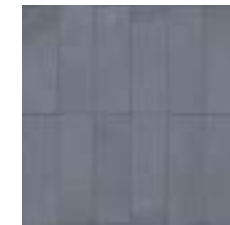

AVIO



SIENNA

COMPOSIZIONE R 29x29 cm . 11⁷/₁₆"x11⁷/₁₆" MATT R10 B



CHALK



ECRU

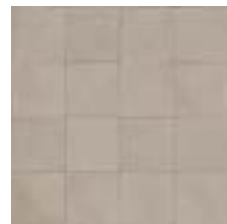

CONCRETE



CLAY



LEAD

COMPOSIZIONE R 29x29 cm . 11⁷/₁₆"x11⁷/₁₆" SOFT



POWDER

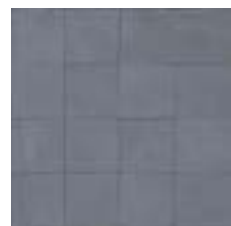

AVIO











SIENNA



CARATTERISTICHE TECNICHE

TILE PERFORMANCE DATA - NOTES TECHNIQUES - TECHNISCHE AUSKÜNFTE - ТЕХНИЧЕСКАЯ ХАРАКТЕРИСТИКА

Classificazione secondo EN ISO 14411 ISO 13006 annesso G gruppo Bla con Ev ≤0,5 % - Classification in accordance with EN ISO 14411 ISO 13006 annex G standards Bla with Ev ≤ 0,5% - Classification selon EN ISO 14411 ISO 13006 annexe G groupe Bla avec Ev ≤0,5% - Klassifizierung gemäß EN ISO 14411 ISO 13006 anlage G Gruppe Bla mit Ev ≤0,5% - Классификация в соответствии с EN ISO 14411 ISO 13006, приложение G, стандарт Bla, где Ev ≤0,5%

| | | | | | | | | |
|----------|------------------------------------------------------------------------------------------------------|----------------------------------------------------------------------------------------------------|---------------------------------------------------------------------------------------------------|--------------------------------------------------------------------------------------------------------|--------------------------------------------------------------------------------------------------------|---------------------------------------------------------------------------------------------------------|----------------------------------------------------------------------------------------------------|----------------------------------------------------------------------------------------------------|
| |  |  |  |  |  |  |  |  |
| | 120x278 cm 47 ² / ₈ "x109 ⁷ / ₁₆ " 6 mm MATT RT | 120x120 cm 47 ² / ₈ "x47 ² / ₈ " 9 mm SOFT RT | 60x120 cm 23 ⁵ / ₈ "x47 ² / ₈ " 9 mm SOFT RT | 80x80 cm 31 ¹ / ₈ "x31 ¹ / ₈ " 9 mm MATT RT R10 B | 60x60 cm 23 ⁵ / ₈ "x23 ⁵ / ₈ " 9 mm MATT RT R10 B | 30x60 cm 11 ³ / ₁₆ "x23 ⁵ / ₈ " 9 mm MATT RT R10 B | 80x80 cm 31 ¹ / ₈ "x31 ¹ / ₈ " 20 mm RT R11 C | 60x60 cm 23 ⁵ / ₈ "x23 ⁵ / ₈ " 20 mm RT R11 C |
| Chalk | | | | | | | | |
| Ecrú | | | | | | | | |
| Concrete | ● | ● | ● | ● | ● | ● | ● | ● |
| Clay | | ● | ● | ● | ● | ● | ● | ● |
| Lead | | ● | ● | ● | ● | ● | ● | ● |
| Powder | | | ● | | | | | |
| Avio | | | ● | | | | | |
| Sienna | | | ● | | | | | |







| | | | |
|----------|-----------------------------------------------------------------------------------------|-----------------------------------------------------------------------------------|-------------------------------------------------------------------------------------|
| |  |  |  |
| | Battiscopa - Bullnose Plinthe - Socket Глинтус | Scalino - Step tread Nez de marche - Stufe Cotto-Art Фронтальная ступень | Angolare - Step tread corner Pièce angulaire - Stufenecke Угловая ступень |
| | 7,2x60 cm 2 ¹⁵ / ₁₆ "x23 ⁵ / ₈ " MATT | 33x120 cm 13"x47 ² / ₈ " MATT | 33x33 cm 13"x13" MATT |
| Chalk | ● | ● | ● |
| Ecrú | ● | ● | ● |
| Concrete | ● | ● | ● |
| Clay | ● | ● | ● |
| Lead | ● | ● | ● |

| IMBALLI - PACKAGING - CONDITIONNEMENT - VERPACKUNGS-EINHEITEN - УПАКОВКА | | | | | | | |
|--------------------------------------------------------------------------|---------------------------------------------------------------------|------------------------------------------|---------|--------|---------------------------|--------|----------|
| Formato - Size - Format - Формат | | Scatola - Box - Boîte - Karton - Коробка | | | Pallet - Palette - Палета | | |
| CM | INCHES | PZ | MQ | KG | SC | MQ | KG |
| 120x278 | 47 ² / ₈ "x109 ⁷ / ₁₆ " | 1 | 3,3221 | -49,56 | 18 | 59,798 | -892,08 |
| 120x120 | 47 ² / ₈ "x47 ² / ₈ " | 2 | 2,85605 | -62,00 | 20 | 57,121 | -1240,00 |
| 60x120 | 23 ⁵ / ₈ "x47 ² / ₈ " | 2 | 1,44 | -30,40 | 35 | 50,4 | -1064,00 |
| 80x80 | 31 ¹ / ₈ "x31 ¹ / ₈ " | 2 | 1,28 | -27,36 | 48 | 61,44 | -1313,28 |
| 60x60 | 23 ⁵ / ₈ "x23 ⁵ / ₈ " | 4 | 1,44 | -28,40 | 30 | 43,20 | -852,00 |
| 30x60 | 11 ³ / ₁₆ "x23 ⁵ / ₈ " | 7 | 1,26 | -25,00 | 40 | 50,40 | -1000,00 |
| 60x60 A E X T R A 2 0 | 23 ⁵ / ₈ "x23 ⁵ / ₈ " | 2 | 0,72 | -32,00 | 30 | 21,60 | -960,00 |
| 80x80 A E X T R A 2 0 | 31 ¹ / ₈ "x31 ¹ / ₈ " | 1 | 0,64 | -29,70 | 42 | 26,88 | -1247,40 |

RT Rettificato, squadrato, monocalibro. - Rectified, squared, one caliber. - Rectifié, mis d'equerre et monocalibre. - Rektifiziert, rechteckig und Ein kaliber. - Ректифицированный, одного калибра.
 ** Disponibile solo su richiesta. - Manufactured only upon special request. - Seulement sur demande. - Nur auf Anfrage. - Производится только по заказу.

Si raccomanda l'utilizzo di una fuga di 2/3 mm al fine di semplificare le operazioni di posa e ottimizzare la naturalezza del risultato finale. - We recommend you a 2/3 mm grout joint to simplify the laying and optimize the naturalness of the final result. - Un joint de 2/3 mm est conseillé afin de simplifier les opérations de pose et optimiser l'effet naturel du résultat final. - Es wird empfohlen mit einer Fuge von 2/3 mm zu arbeiten, um am Ende den Verlegevorgang zu vereinfachen und die bestmögliche Natürlichkeit der Arbeit zu erzielen. - Для облегчения операций укладки и повышения натуральности вида конечного результата рекомендуется выполнять шов шириной 2-3 мм.

Al fine di facilitare la manutenzione ordinaria si raccomanda di effettuare un lavaggio acido dopo 48 ore dalla stuccatura con un acido specifico per grès porcellanato. - In order to favour the ordinary maintenance procedures, it is recommended to carry out an acid wash of the surface after 48 hours from grout filling using an acid agent specific for porcelain stoneware tiles. - Afin de faciliter l'entretien ordinaire de votre carrelage, nous vous conseillons de le laver 48 heures après le colmatage des joints, avec un acide spécifique pour grès cérame. - Um die Instandhaltung zu erleichtern, empfiehlt es sich 48 Stunden nach der Stuckatur mit einer sauren Lösung speziell für Feinsteinzeug zu waschen. - Чтобы упростить уход за плиткой, спустя 48 часов после затирки швов рекомендуется выполнить обработку кислотным продуктом, пригодным для керамогранита.

| | CARATTERISTICA TECNICA TECHNICAL CHARACTERISTIC CARACTERISTIQUE TECHNIQUE TECHNISCHE DATEN ТЕХНИЧЕСКАЯ ХАРАКТЕРИСТИКА | METODO DI PROVA TESTS METHOD METHODE D'ESSAI TESTMETHODE МЕТОДИСПЫТАНИЯ | VALORE * MEDIO "CAESAR" AVERAGE "CAESAR" VALUE * VALEUR * MOYEN "CAESAR" "CAESAR" DURCHSCHNITTSWERT * СРЕДНЕЕ ЗНАЧЕНИЕ "CAESAR" * | VALORE * MEDIO "CAESAR" AVERAGE "CAESAR" VALUE A E X T R A 2 0 OPEN YOUR STYLE |
|---------------------------------------------------------------------------------------|-------------------------------------------------------------------------------------------------------------------------------------------------------------------------------------------------------------------------------------|-------------------------------------------------------------------------------------|-----------------------------------------------------------------------------------------------------------------------------------------------|-----------------------------------------------------------------------------------------------------------------------------------------------------------------------------------------------------------------------------------------------------------------------------------------|
|  | Dimensione - Size Dimension - Abmessungen - Размер | ISO 10545-2 | Conforme - In accordance Conforme - Erfüllt - Соответствует | Conforme - In accordance Conforme - Erfüllt - Соответствует |
|  | Assorbimento d'acqua* - Water absorption* Absorption d'eau* - Wasseraufnahme* - % Поглощения воды* | ISO 10545-3 | ≤ 0,1% | ≤ 0,1% |
|  | Resistenza alla flessione* - Bending strength* Résistance à la flexion* - Biegezugfestigkeit* - Упругость* | ISO 10545-4 | Conforme - In accordance Conforme - Erfüllt - Соответствует | Non applicabile a piastrelle con una forza di rottura Not applicable to tiles with a breaking strength N'est pas applicable aux carreaux avec une charge de rupture Nicht anwendbar bei Fliesen mit einer Bruchlast Не применяется в отношении плиток с прочностью на изрыв |
|  | Sforzo di rottura (S) - Breaking strength Charge de rupture - Bruchlast - Разрушающее усилие | ISO 10545-4 | Sps ≥ 7,5 mm S ≥ 1300 N | > 10.000 N |
|  | Resistenza all'abrasione profonda* - Deep scratch resistance* Résistance à l'abrasion profonde* - Widerstand gegen Tiefenverschleiß* Устойчивость глубокому истиранию* | ISO 10545-6 | Conforme - In accordance Conforme - Erfüllt - Соответствует | Conforme - In accordance Conforme - Erfüllt - Соответствует |
|  | Coefficiente di dilatazione termica lineare* - Thermal linear expansion coefficient* Coefficient de dilatation thermique linéaire* - Koeffizient der linearen thermischen Dehnung* - Коэффициент линейного теплового расширения* | ISO 10545-8 | ≈ 7 (10 ⁻⁶ °C ⁻¹) | ≈ 7 (10 ⁻⁶ °C ⁻¹) |
|  | Resistenza agli sbalzi termici* - Thermal shock resistance* Résistance aux écarts de température* - Temperaturwechsel Beständigkeit* Устойчивость к тепловому перепаду* | ISO 10545-9 | Resistente - Resistant Résistante - Beständig - Стойкий | Resistente - Resistant Résistante - Beständig - Стойкий |
|  | Dilatazione all'umidità* - Expansion in humidity* Dilatation à l'humidité* - Feuchtigkeitsausdehnung* Расширение в условиях влажности* | ISO 10545-10 | ≤ 0,1 (mm/m) | ≤ 0,1 (mm/m) |
|  | Resistenza al gelo* - Frost resistance* Résistance au gel* - Frostbeständigkeit* - Морозостойкость* | ISO 10545-12 | Resistente - Resistant Résistante - Beständig - Стойкий | Resistente - Resistant Résistante - Beständig - Стойкий |
|  | Resistenza all'attacco chimico* - Resistance to chemical attack* Résistance à l'attaque chimique* - Beständigkeit gegen Chemikalien* Устойчивость к химическому воздействию* | ISO 10545-13 | Resistente - Resistant Résistante - Beständig - Стойкий | Resistente - Resistant Résistante - Beständig - Стойкий |
|  | Carico statico - Static load Charge statique - Statische Last Статическая нагрузка | EN 12825 | - | 60x60 KN>7,0 80x80 KN>3,0 |
|  | Classe di carico di rottura*** - Breaking load class*** Classe de charge de rupture*** - Bruchlastklasse*** Класс стойкости к разрушающей нагрузке*** | EN 1339 | - | Centro - Centre - Au centre - Mitte - По центру KN>5,0 Centro lato - Side centre - Au centre latéralement Mitte Seite - По центру грани KN>3,0 Diagonale - Diagonal - En diagonale Diagonal - По диагонали KN>8,0 KN>6,5 |
|  | Resistenza alle macchie* - Resistance to stains* Résistance aux taches* - Fleckenbeständigkeit* Устойчивость к образованию пятен* | ISO 10545-14 | Pulibile - Cleanable Nettoyable - Leicht zu reinigen Чистящийся | U11 T11 Pulibile - Cleanable Nettoyable - Leicht zu reinigen Чистящийся |
|  | Resistenza allo scivolamento** - Slip resistance** Résistance au glissement** - Rutschhemmende Eigenschaft** Сопротивление скольжению** | DIN 51130 - DIN 51097 | R9 Matt 120x278 | R10 B Matt - Soft |
|  | Spessore nominale - Nominal Thickness Épaisseur nominal - Nominalstärke Номинальная толщина | ▲ ANSI A326.3 | Wet DCOF ≈ 0,42 | Wet DCOF ≈ 0,55 |
|  | | | 6 mm 120x278 9 mm 120x120 - 60x120 - 80x80 - 60x60 - 30x60 | 20 mm |

* Valori medi riferiti agli ultimi due anni di produzione e relativi alla finitura naturale del prodotto - Average values referred to the last two years of production and related to the matt finish of the product - Valeurs moyennes des deux dernières années de production et relatifs à la finition naturelle du produit - Durchschnittswerte, die sich auf die letzten zwei Produktionsjahre beziehen und auf die matte Obaerfläche - Средние значения относятся к последним двум годам производства и натуральной отделке поверхности

** Valori relativi alla finitura naturale del prodotto ed a test effettuati da laboratori esterni accreditati, disponibili in azienda; ci rendiamo disponibili alla verifica dell'eventuale lotto interessato all'acquisto. - As far as values relating to the matt finish of the product and to tests carried out by certified external laboratories whose results are available upon request at Headoffice, we are willing to check the lot you are interested in purchasing. - Valeurs se référant à la finition naturelle du produit selon des tests effectués par des laboratoires extérieurs accrédités et à la disposition de toute personne intéressée auprès de nos bureaux; nous sommes disponibles pour le contrôle de l'éventuel lot concerné par l'achat. - Werte bezogen auf das natürliche Produktfinish und in anerkannten externen Labors geprüft, im Unternehmen erhältlich; für eventuelle Prüfungen der zu erwerbenden Warenposten stehen wir gern zur Verfügung. - Значения, касающиеся натуральных характеристик изделий и тестов, выполненных внешними авторизованными лабораториями, имеются в компании. Мы готовы выполнить проверку партии товара, которую намереваетесь приобрести.

*** Dato riferito al formato 60x60 cm. - Detail referred to the 60x60 cm size. - Donnée se rapportant au format 60x60 cm. - Auf die Formate 60x60 cm bezogen. - Значения, касающиеся натуральных характеристик изделий и тестов.

• Per prodotti chimici di uso domestico e additivi per piscina. - For domestic chemicals and swimming pool additives. - Pour produits chimiques à usage domestique et additifs pour piscines. - Für chemische Produkte für den Hausgebrauch und Schwimmbadzusätze. - Для бытовых химикатов и добавок для бассейнов.

▲ Valori wet DCOF specifici disponibili in azienda - Wet DCOF specific values available at the company - Valeurs wet DCOF spécifiques disponibles à l'usine - Prüfwerte Wet DCOF stehen im Werk zur Verfügung - Показатели wet DCOF доступны при запросе

Le tonalità dei campioni sono da considerarsi puramente indicative. - Tones of samples are indicative. - Les tonalités des échantillons sont purement indicatives. - Die farbtöne der Muster sind als rein indicativ zu betrachten. - Тона образцов ориентировочные.

Marble Look

La bellezza fuori dal tempo dei marmi più pregiati e particolari, riletta con gusto attuale e di tendenza: nobiltà contemporanea per i tuoi spazi architettonici.

The timeless beauty of the most precious and particular marbles, restyled with a trendy and topical twist: contemporary nobleness for your architectural spaces.

La beauté intemporelle des marbres les plus aimés et caractéristiques, revisitée dans un esprit actuel et tendance : noblesse contemporaine pour vos espaces architecturaux.

Die zeitlose Schönheit der edelsten und außergewöhnlichsten Marmorarten, aktuell neuinterpretiert: zeitgemäße Noblesse für Ihre architektonischen Räume.

Непреходящая красота самых редких и необычных видов мрамора в актуальной и трендовой интерпретации: современное благородство для ваших архитектурных пространств.



Marble Look

The collections

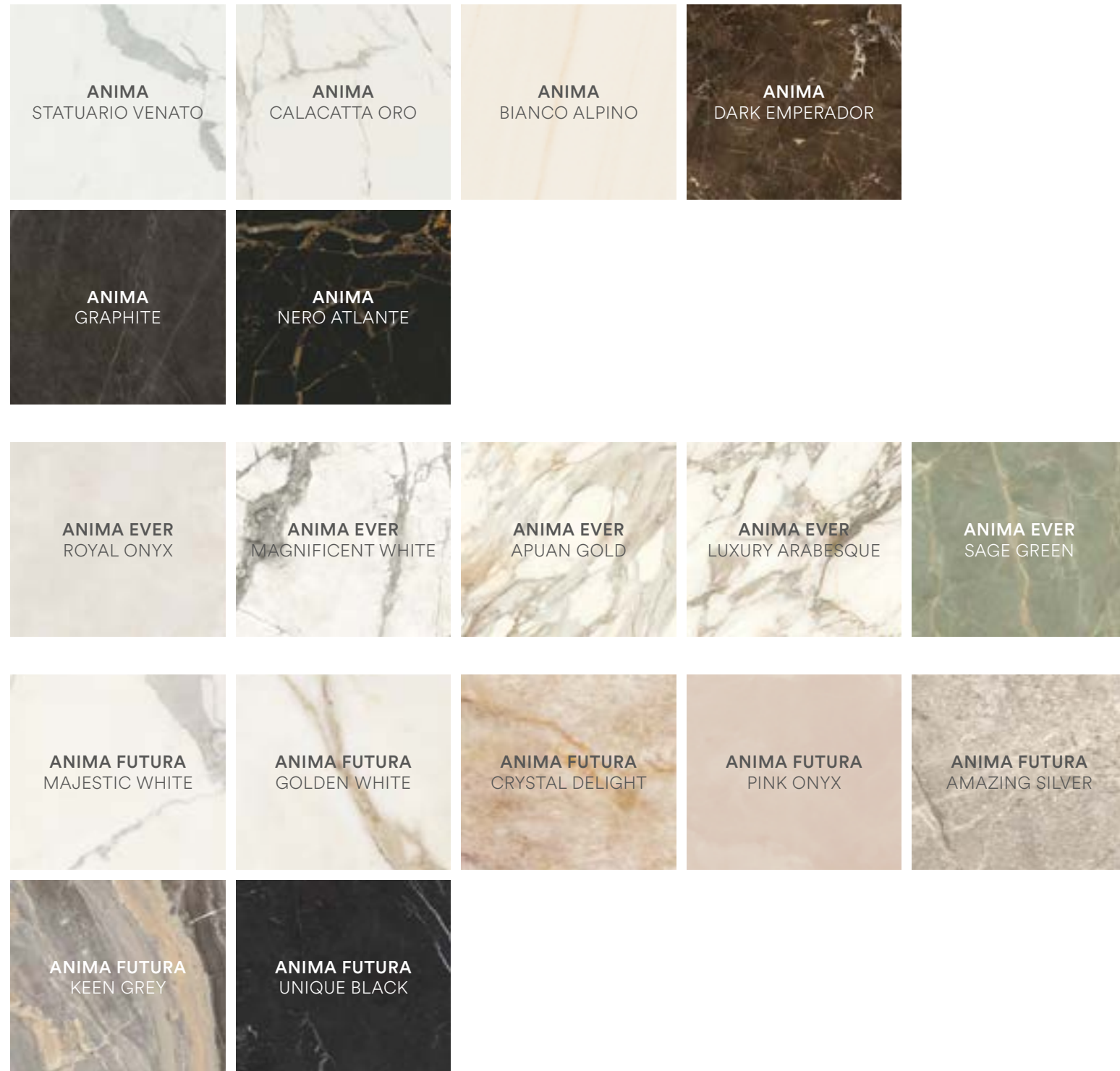

Anima

Redefined elegance



Anima mette al servizio delle esigenze progettuali 6 ispirazioni marmoree in 3 finiture superficiali, per trasformare gli spazi con il suo carattere esclusivo e ricercato.

Anima places 6 inspirational marble types and 3 surfaces finishes at the disposal of every project need, in order to transform spaces with an exclusive and sought-after charm.

Anima met au service des exigences de conception 6 inspirations de marbre déclinées en 3 finitions de surface, pour transformer les espaces avec son caractère exclusif et recherché.

Anima für jeden Projektbedarf 6 Marmorinspirationen mit 3 Oberflächenversionen, die jeden Raum mit ihrem exklusiven und erlesenen Charakter prägen.

Anima Коллекция имитирует 6 пород мрамора в 3 вариантах поверхностной отделки и позволяет создать эксклюзивные и изысканные по характеру интерьеры.



Info
Resources
Tools



MARBLE LOOK

Floor: STATUARIO VENATO 60x120 LUCIDATO RT
Wall: STATUARIO VENATO 60x120 LUCIDATO RT, LIFE NOCE 20x120 MATT RT

Anima



MARBLE LOOK

Colori - Formati

Colors - Sizes

160x320 . 120x278 6 mm LUCIDATO RT
 160x320 . 120x278 6 mm SILK RT
 120x120 . 60x120 . 60x60 . 30x60 9 mm LUCIDATO RT
 120x120 . 60x120 . 60x60 . 30x60 9 mm MATT RT

STATUARIO VENATO



CALACATTA ORO



BIANCO ALPINO

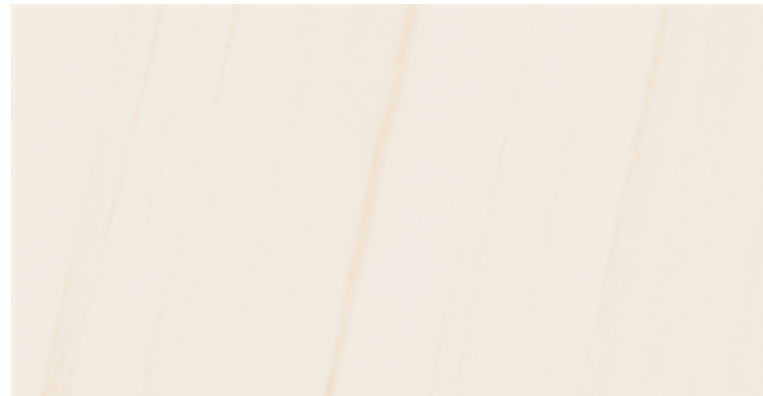

DARK EMPERADOR

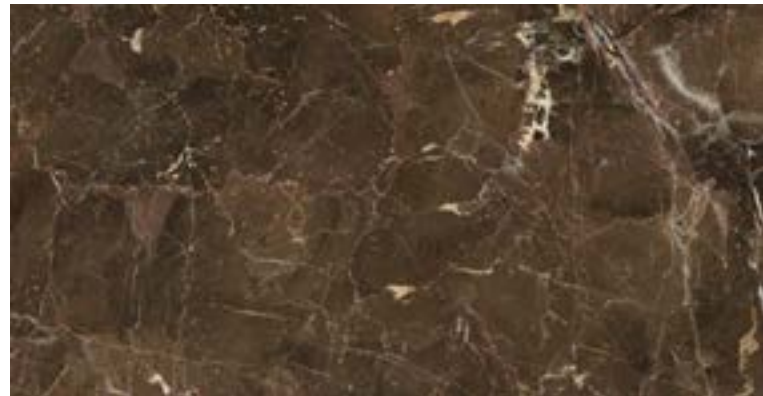

GRAPHITE



NERO ATLANTE

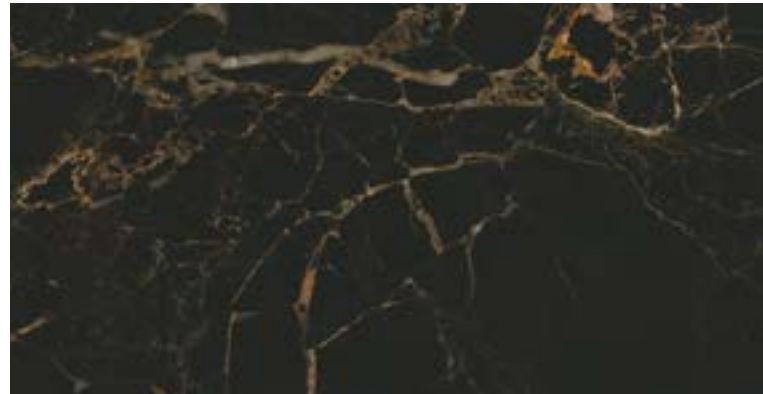

6 mm



160x320
63"x126"

120x278
47⁵/₈"x109⁷/₁₆"

LUCIDATO RT
SILK RT

9 mm

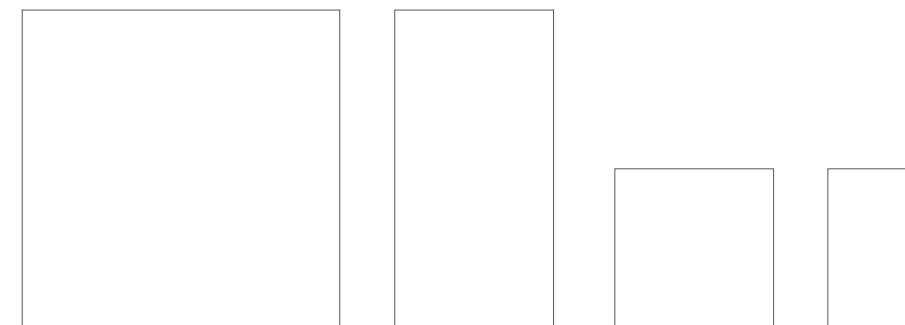

120x120
47¹/₈"x47¹/₈"

60x120
23⁵/₈"x47¹/₈"

60x60
23⁵/₈"x23⁵/₈"

30x60
11¹⁵/₁₆"x23⁵/₈"

LUCIDATO RT
MATT RT

Anima

MARBLE LOOK

La gamma

The range

STATUARIO VENATO

CALACATTA ORO

BIANCO ALPINO

DARK EMPERADOR

GRAPHITE

NERO ATLANTE

LUCIDATO RT

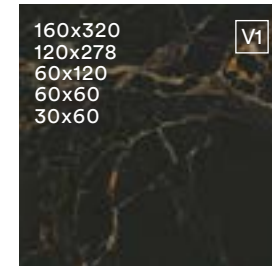
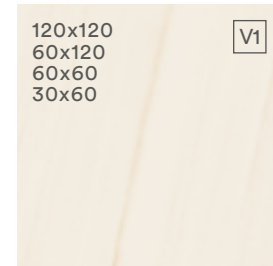

SILK RT

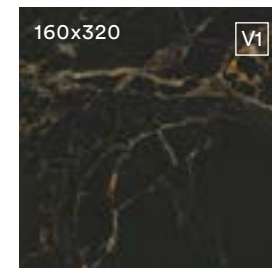

MATT RT

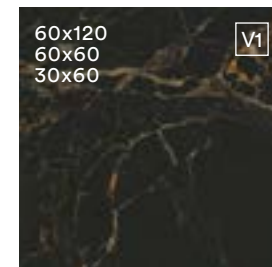

RT Rettificato, squadrato, monocalibro. - Rectified, squared, one caliber. - Rectifié, mis d'équerre et monocalibre. - Rektifiziert, rechtwinkelig und Ein kaliber. - Ректифицированный, одного калибра.

Decori

Decors

COMPOSIZIONE F 30x30 cm . 11³/₁₆"x11³/₁₆" LUCIDATO



STATUARIO VENATO



CALACATTA ORO



BIANCO ALPINO



DARK EMPERADOR



GRAPHITE

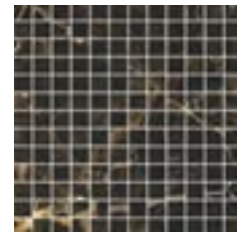

NERO ATLANTE

COMPOSIZIONE ESAGONO 28,5x33 cm . 11³/₁₆"x13" LUCIDATO



STATUARIO VENATO



CALACATTA ORO



BIANCO ALPINO



DARK EMPERADOR



GRAPHITE



NERO ATLANTE

LISTELLO 5,7x60 cm . 2²/₈"x23⁵/₈" LUCIDATO



STATUARIO VENATO



CALACATTA ORO



BIANCO ALPINO



DARK EMPERADOR



GRAPHITE



NERO ATLANTE

TOZZETTO 5,7x5,7 cm . 2²/₈"x2²/₈" LUCIDATO



STATUARIO VENATO



CALACATTA ORO



BIANCO ALPINO



DARK EMPERADOR



GRAPHITE



NERO ATLANTE

CARATTERISTICHE TECNICHE

TILE PERFORMANCE DATA - NOTES TECHNIQUES - TECHNISCHE AUSKÜNFTE - ТЕХНИЧЕСКАЯ ХАРАКТЕРИСТИКА

Classificazione secondo EN ISO 14411 ISO 13006 annesso G gruppo Bla con Ev ≤0,5 % - Classification in accordance with EN ISO 14411 ISO 13006 annex G standards Bla with Ev ≤ 0,5% - Classification selon EN ISO 14411 ISO 13006 annexe G groupe Bla avec Ev ≤0,5% - Klassifizierung gemäß EN ISO 14411 ISO 13006 anlage G Gruppe Bla mit Ev ≤0,5% - Классификация в соответствии с EN ISO 14411 ISO 13006, приложение G, стандарт Bla, где Ev ≤0,5%

| | 160x320 cm 63"x126" 6 mm | | 120x278 cm 47 1/8"x109 7/8" 6 mm | | 120x120 cm 47 1/8"x47 1/8" 9 mm | | 60x120 cm 23 5/8"x47 1/8" 9 mm | | 60x60 cm 23 5/8"x23 5/8" 9 mm | | 30x60 cm 11 3/8"x23 5/8" 9 mm | |
|------------------|--------------------------------|---------|----------------------------------------|---------|---------------------------------------|---------|--------------------------------------|---------|-------------------------------------|---------|-------------------------------------|---------|
| | LUCIDATO RT | SILK RT | LUCIDATO RT | SILK RT | LUCIDATO RT | MATT RT | LUCIDATO RT | MATT RT | LUCIDATO RT | MATT RT | LUCIDATO RT | MATT RT |
| Statuario Venato | ● | ● | ● | ● | ● | ● | ● | ● | ● | ● | ● | ● |
| Calacatta Oro | ● | ● | ● | ● | ● | ● | ● | ● | ● | ● | ● | ● |
| Bianco Alpino | | | | | ● | | ● | | ● | | ● | |
| Dark Emperador | | | | | | | | | ● | | | |
| Graphite | | | | ● | | ● | ● | ● | ● | ● | ● | ● |
| Nero Atlante | ● | ● | ● | | | | ● | ● | ● | ● | ● | ● |

| | 7,2x60 cm 2 7/8"x23 5/8" | | 33x60 cm 13"x23 5/8" | | 33x33 cm 13"x13" | |
|------------------|-----------------------------|------|-------------------------|------|---------------------|------|
| | LUCIDATO | MATT | LUCIDATO | MATT | LUCIDATO | MATT |
| Statuario Venato | ● | | ● | | ● | |
| Calacatta Oro | ● | ● | ● | ● | ● | ● |
| Bianco Alpino | ● | | ● | | ● | |
| Dark Emperador | ● | | ● | | ● | |
| Graphite | ● | ● | ● | ● | ● | ● |
| Nero Atlante | ● | ● | ● | ● | ● | ● |

| IMBALLI - PACKAGING - CONDITIONNEMENT - VERPACKUNGS-EINHEITEN - УПАКОВКА | | | | | | | |
|--------------------------------------------------------------------------|------------------------------------------|----|--------|---------------------------|----|-------|----------|
| Formato - Size - Format - Формат | Scatola - Box - Boîte - Karton - Коробка | | | Pallet - Palette - Палета | | | |
| CM | INCHES | PZ | MQ | KG | SC | MQ | KG |
| 160x320 | 63"x126" | 1 | 5,12 | -78,00 | 14 | 71,68 | -1092,00 |
| 120x278 | 47 1/8"x109 7/8" | 1 | 3,3221 | -49,56 | 18 | 59,79 | -892,08 |
| 120x120 | 47 1/8"x47 1/8" | 2 | 2,856 | -62,00 | 20 | 57,12 | -1240,00 |
| 60x120 | 23 5/8"x47 1/8" | 2 | 1,44 | -32,00 | 35 | 50,40 | -1120,00 |
| 60x60 LUCIDATO | 23 5/8"x23 5/8" | 3 | 1,08 | -25,75 | 40 | 43,20 | -1030,00 |
| 60x60 MATT | 23 5/8"x23 5/8" | 4 | 1,44 | -28,40 | 30 | 43,20 | -852,00 |
| 30x60 LUCIDATO | 11 3/8"x23 5/8" | 7 | 1,26 | -25,00 | 40 | 50,40 | -1000,00 |
| 30x60 MATT | 11 3/8"x23 5/8" | 7 | 1,26 | -27,15 | 40 | 50,40 | -1086,00 |

RT Rettificato, squadrato, monocalibro. - Rectified, squared, one caliber. - Rectifié, mis d'equerre et monocalibre. - Rektifiziert, rechteckig und Ein kaliber. - Ректифицированный, одного калибра.

**** Disponibile solo su richiesta.** - Manufactured only upon special request. - Seulement sur demande. - Nur auf Anfrage. - Производится только по заказу.

L'utilizzo della finitura LUCIDATO e SILK è limitato ai rivestimenti e alla posa a pavimento in ambito residenziale, o comunque in aree scarsamente sollecitate, evitando in ogni caso il contatto diretto con aree esterne o nelle quali siano richieste prestazioni antiscivolo. Le finiture LUCIDATO e SILK sono il risultato di particolari lavorazioni meccaniche e possono presentare occasionali puntinature e avvallamenti, così come disuniformità nella lucentezza. Tali peculiarità sono da intendersi come caratteristiche integranti dei prodotti, allo scopo di ottenere una maggiore naturalezza. - The use of the LUCIDATO and SILK finishes is limited to wall cladding and floor application in residential venues and in spaces subject to low foot traffic, avoiding the direct contact with outdoor areas which require anti-slip features. The LUCIDATO and SILK finishes are the result of a special mechanical process and can manifest small dots or hollows as well as a non-uniform shine all over the surface. These particularities are to be considered as intrinsic features of the product which give them a more natural appeal. - L'utilisation de la finition LUCIDATO et SILK est limitée aux revêtements et à la pose au sol dans des environnements résidentiels, ou dans tous les cas dans des aires faiblement sollicitées, en évitant ainsi le contact direct avec les aires extérieures ou dans lesquelles sont requises des prestations antidérapantes. Les finitions LUCIDATO et SILK sont le résultat de façonnages mécaniques particuliers et peuvent présenter d'éventuelles petites taches ou de légers affaissements ou bien des différences de brillance. Ces particularités doivent être considérées comme des caractéristiques du produit à part entière. Le façonnage de cette finition a justement pour but d'obtenir cet effet naturel et différé. - Die Verwendung der Version LUCIDATO und SILK ist auf Wand und Boden im Wohnbereich bzw. in wenig belasteten Bereichen beschränkt, und in jedem Fall ist der direkte Kontakt mit Außenbereichen sowie mit Rutschfestigkeit erfordernden Bereichen zu vermeiden. Die Versionen LUCIDATO und SILK sind Ergebnisse besonderer maschineller Bearbeitungen; sie können gelegentlich Nadelstiche und Krater sowie uneinheitlichen Glanz aufweisen. Es handelt sich hierbei um Produktmerkmale, mit denen eine besonders natürliche Wirkung erzeugt wird. - Плитки с поверхностью LUCIDATO и SILK можно укладывать только на стены и полы в жилых помещениях или, во всяком случае, в контекстах, где покрытие подвергается невысокой эксплуатационной нагрузке. Не рекомендуется укладывать их на улице или на участках, где от покрытия требуется высокое сопротивление скольжению. Поверхности LUCIDATO и SILK получаются в результате специальной механической обработки и могут иметь небольшие сколы, углубления или неравномерный блеск. Эти особенности являются характеристикой изделий и имеют целью придать им большую натуральность.

Si raccomanda l'utilizzo di una fuga di 2/3 mm al fine di semplificare le operazioni di posa e ottimizzare la naturalezza del risultato finale. - We recommend you a 2/3 mm grout joint to simplify the laying and optimize the naturalness of the final result. - Un joint de 2/3 mm est conseillé afin de simplifier les opérations de pose et optimiser l'effet naturel du résultat final. - Es wird empfohlen mit einer Fuge von 2/3 mm zu arbeiten, um am Ende den Verlegvorgang zu vereinfachen und die bestmögliche Natürlichkeit der Arbeit zu erzielen. - Для облегчения операций укладки и повышения натуральности вида конечного результата рекомендуется выполнять шов шириной 2-3 мм.

Al fine di facilitare la manutenzione ordinaria si raccomanda di effettuare un lavaggio acido dopo 48 ore dalla stuccatura con un acido specifico per grès porcellanato. - In order to favour the ordinary maintenance procedures, it is recommended to carry out an acid wash of the surface after 48 hours from grout filling using an acid agent specific for porcelain stoneware tiles. - Afin de faciliter l'entretien ordinaire de votre carrelage, nous vous conseillons de le laver 48 heures après le colmatage des joints, avec un acide spécifique pour grès cérame. - Um die Instandhaltung zu erleichtern, empfiehlt es sich 48 Stunden nach der Stuckatur mit einer sauren Lösung speziell für Feinsteinzeug zu waschen. - Чтобы упростить уход за плиткой, спустя 48 часов после затирки швов рекомендуется выполнить обработку кислотным продуктом, пригодным для керамогранита.

| | CARATTERISTICA TECNICA TECHNICAL CHARACTERISTIC CARACTERISTIQUE TECHNICQUE TECHNISCHE DATEN ТЕХНИЧЕСКАЯ ХАРАКТЕРИСТИКА | METODO DI PROVA TESTS METHOD METHODE D'ESSAI TESTMETHODE МЕТОД ИСПЫТАНИЯ | VALORE * MEDIO "CAESAR" AVERAGE "CAESAR" VALUE * VALEUR * MOYEN "CAESAR" "CAESAR" DURCHSCHNITTSWERT * СРЕДНЕЕ ЗНАЧЕНИЕ "CAESAR" * | | |
|--|--------------------------------------------------------------------------------------------------------------------------------------------------------------------------------------------------------------------------------------------|--------------------------------------------------------------------------------------|-----------------------------------------------------------------------------------------------------------------------------------------------|-------------------------------------------------------------------------|-------------------------------------------------------------------------|
| | | | Lucidato | Silk | Matt |
| | Dimensione - Size Dimension - Abmessungen - Размер | ISO 10545-2 | Conforme - In accordance Conforme - Erfüllt - Соответствует | Conforme - In accordance Conforme - Erfüllt - Соответствует | Conforme - In accordance Conforme - Erfüllt - Соответствует |
| | Assorbimento d'acqua* - Water absorption* Absorption d'eau* - Wasseraufnahme* - % Поглощения воды* | ISO 10545-3 | ≤ 0,1% | ≤ 0,1% | ≤ 0,1% |
| | Resistenza alla flessione* - Bending strength* Résistance à la flexion* - Biegezugfestigkeit* - Упругость* | ISO 10545-4 | Conforme - In accordance Conforme - Erfüllt - Соответствует | Conforme - In accordance Conforme - Erfüllt - Соответствует | Conforme - In accordance Conforme - Erfüllt - Соответствует |
| | Resistenza all'urto - Impact resistance Résistance au choc - Schlagfestigkeit - Ударопрочность | ISO 10545-5 | ≥ 0,80 | ≥ 0,80 | ≥ 0,80 |
| | Resistenza all'abrasione profonda* - Deep scratch resistance* Résistance à l'abrasion profonde* - Widerstand gegen Tiefenverschleiß* Устойчивость к глубокому истиранию* | ISO 10545-6 | - | Conforme - In accordance Conforme - Erfüllt - Соответствует | Conforme - In accordance Conforme - Erfüllt - Соответствует |
| | Coefficiente di dilatazione termica lineare* - Thermal linear expansion coefficient* Coefficient de dilatation thermique linéaire* - Koeffizient der linearen thermischen Dehnung* - Коэффициент линейного теплового расширения* | ISO 10545-8 | ≈ 7 (10 ⁻⁶ °C ⁻¹) | ≈ 7 (10 ⁻⁶ °C ⁻¹) | ≈ 7 (10 ⁻⁶ °C ⁻¹) |
| | Resistenza agli sbalzi termici* - Thermal shock resistance* Résistance aux écarts de température* - Temperaturwechsel Beständigkeit* Устойчивость к тепловому перепаду* | ISO 10545-9 | Conforme - In accordance Conforme - Erfüllt - Соответствует | Conforme - In accordance Conforme - Erfüllt - Соответствует | Conforme - In accordance Conforme - Erfüllt - Соответствует |
| | Dilatazione all'umidità* - Expansion in humidity* Dilatation à l'humidité* - Feuchtigkeitssausdehnung* Расширение в условиях влажности* | ISO 10545-10 | Conforme - In accordance Conforme - Erfüllt - Соответствует | Conforme - In accordance Conforme - Erfüllt - Соответствует | Conforme - In accordance Conforme - Erfüllt - Соответствует |
| | Resistenza al cavillo - Cracking resistance Résistance aux craquelures - Haariß-Beständigkeit Устойчивость эмали к краquelуру | ISO 10545-11 | Conforme - In accordance Conforme - Erfüllt - Соответствует | - | - |
| | Resistenza al gelo* - Frost resistance* Résistance au gel* - Frostbeständigkeit* - Морозостойчивость* | ISO 10545-12 | Resistente - Resistant Résistante - Beständig - Стойкий | Resistente - Resistant Résistante - Beständig - Стойкий | Resistente - Resistant Résistante - Beständig - Стойкий |
| | Resistenza all'attacco chimico ● - Resistance to chemical attack ● Résistance à l'attaque chimique ● - Beständigkeit gegen Chemikalien ● Устойчивость к химическому воздействию ● | ISO 10545-13 | Resistente - Resistant Résistante - Beständig - Стойкий | Resistente - Resistant Résistante - Beständig - Стойкий | Resistente - Resistant Résistante - Beständig - Стойкий |
| | Resistenza alle macchie* - Resistance to stains* Résistance aux taches* - Fleckenbeständigkeit * Устойчивость к образованию пятен* | ISO 10545-14 | Pulibile - Cleanable Nettoyable - Leicht zu reinigen - Чистящийся | Pulibile - Cleanable Nettoyable - Leicht zu reinigen - Чистящийся | Pulibile - Cleanable Nettoyable - Leicht zu reinigen - Чистящийся |
| | Resistenza allo scivolamento** - Slip resistance** Résistance au glissement** - Rutschhemmende Eigenschaft** Сопротивление скольжению** | DIN 51130 - DIN 51097 ▲ ANSI A326.3 | - | - | R9 Matt Wet DCOF ≥ 0,42 |
| | Resistenza all'abrasione superficiale - Surface abrasion resistance Résistance à l'abrasion superficielle - Widerstand gegen Oberächenverschleiß Сопротивление на изгиб и усилию на излом | EN ISO 10545-7 | - | - | - |
| | Durezza Mohs - Mohs hardness Dureté Mohs - Ritzhärte nach Mohs - Устойчивость к изгибу | EN 101 | Coeff. 5 | Coeff. 6 | Coeff. 6 |
| | Spessore nominale - Nominal Thickness Épaisseur nominal - Nominalstärke Номинальная толщина | | 6 mm 160x320 - 120x278 9 mm 120x120 - 60x120 - 60x60 - 30x60 | 6 mm | 9 mm |

* Valori medi riferiti agli ultimi due anni di produzione e relativi alla finitura naturale del prodotto - Average values referred to the last two years of production and related to the matt finish of the product - Valeurs moyennes des deux dernières années de production et relatifs à la finition naturelle du produit - Durchschnittswerte, die sich auf die letzten zwei Produktionsjahre beziehen und auf die matte Obaerfläche - Средние значения относятся к последним двум годам производства и натуральной отделке поверхности

** Valori relativi alla finitura naturale del prodotto ed a test effettuati da laboratori esterni accreditati, disponibili in azienda; ci rendiamo disponibili alla verifica dell'eventuale lotto interessato all'acquisto. - As far as values relating to the matt finish of the product and to tests carried out by certified external laboratories whose results are available upon request at Headoffice, we are willing to check the lot you are interested in purchasing. - Valeurs se référant à la finition naturelle du produit selon des tests effectués par des laboratoires extérieurs accrédités et à la disposition de toute personne intéressée auprès de nos bureaux; nous sommes disponibles pour le contrôle de l'éventuel lot concerné par l'achat. - Werte bezogen auf das natürliche Produktfinish und in anerkannten externen Labors geprüft, im Unternehmen erhältlich; für eventuelle Prüfungen der zu erwerbenden Warenposten stehen wir gern zur Verfügung. - Значения, касающиеся натуральных характеристик изделий и тестов, выполненных внешними авторизованными лабораториями, имеются в компании. Мы готовы выполнить проверку партии товара, которую намереваемся приобрести.

• Per prodotti chimici di uso domestico e additivi per piscina. - For domestic chemicals and swimming pool additives. - Pour produits chimiques à usage domestique et additifs pour piscines. - Für chemische Produkte für den Hausgebrauch und Schwimmbadzusätze. - Для бытовых химикатов и добавок для бассейнов.

▲ Valori wet DCOF specifici disponibili in azienda - Wet DCOF specific values available at the company - Valeurs wet DCOF spécifiques disponibles à l'usine - Prüfwerte Wet DCOF stehen im Werk zur Verfügung - Показатели wet DCOF доступны при запросе

Le tonalità dei campioni sono da considerarsi puramente indicative. - Tones of samples are indicative. - Les tonalités des échantillons sont purement indicatives. Die farböne der Muster sind als rein indicativ zu betrachten. - Тона образцов ориентировочные.

Anima Ever

Timeless elegance



Il marmo è un'emozione senza tempo, vissuta ogni volta come fosse la prima. Selezionando alcune varietà molto prestigiose, Ceramiche Caesar amplia il proprio progetto di lastre in grès porcellanato ispirate a questa nobile materia. Il risultato è una nuova gamma di proposte che sposano la ricercatezza stilistica a un'eccezionale versatilità d'impiego, dando un volto contemporaneo a un'emozione che non conosce stagioni.

Marble evokes a timeless emotion, and awakens an experience that renews itself every time. By selecting very prestigious varieties of marble, Ceramiche Caesar has expanded its range of porcelain stoneware slabs that draw inspiration from this noble material. The result is a new range of ideas that combine a refined style with an exceptional versatility, to give a contemporary feel for all seasons.

Le marbre est une émotion intemporelle, vécue à chaque fois comme si c'était la première fois. Par la sélection de variétés très prestigieuses, Ceramiche Caesar développe son projet de dalles en grès cérame inspiré de ce matériau noble. Le résultat est une nouvelle gamme de créations qui allient raffinement stylistique et utilisation polyvalente exceptionnelle en donnant un visage contemporain à une émotion qui ne connaît pas de saisons.

Marmor weckt zeitlose Emotionen, die wir immer wieder erleben, als wäre es das erste Mal. Ceramiche Caesar hat einige besonders kostbare Sorten ausgewählt, um sein Angebot an Feinsteinzeugplatten, die dieses edle Material nachbilden, zu erweitern. Das Ergebnis ist ein neues Sortiment aus Produkten, die erlesenen Stil mit einer außergewöhnlichen Verwendungsvielfalt vereint und gewissermaßen ewigen Emotionen eine zeitgemäße Optik verleiht.

Мрамор - это не знающие времени эмоции, которые воспринимаются каждый раз, как в первый раз. Выбрав некоторые очень престижные сорта, Ceramiche Caesar расширяет свой проект керамогранитных плит, источником вдохновения для которых послужил этот ценный материал. Результатом стала новая линейка предложений, в которой сочетается стилистическая изысканность и великолепная универсальность применения, наделяя современностью не знающие смены времен года эмоции.



Info
Resources
Tools



MARBLE LOOK

Floor: APUAN GOLD 80x80 LUCIDATO RT
Wall: APUAN GOLD 160x320 SILK RT, SAGE GREEN 60x120 LUCIDATO RT

Anima Ever



MARBLE LOOK

Colori - Formati

Colors - Sizes

- 160x320 6 mm SILK RT
- 120x278 6 mm LUCIDATO RT
- 120x120 . 60x120 . 80x160 . 80x80 9 mm LUCIDATO RT
- 60x120 9 mm MATT RT

MAGNIFICENT WHITE



LUXURY ARABESQUE



APUAN GOLD



SAGE GREEN



ROYAL ONYX



SILK RT

LUCIDATO RT

6 mm



160x320
63"x126"

6 mm

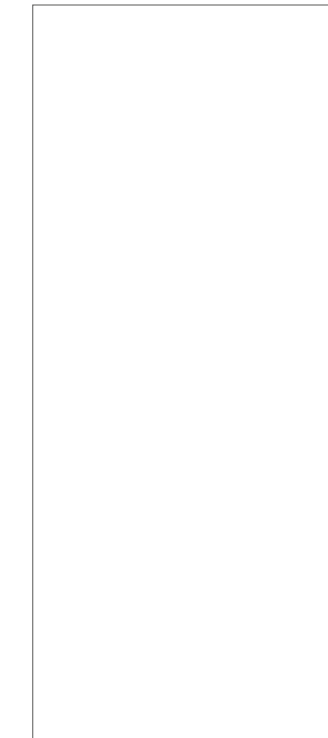

120x278
47²/₈"x109⁷/₈"

LUCIDATO RT

9 mm



120x120
47²/₈"x47²/₈"

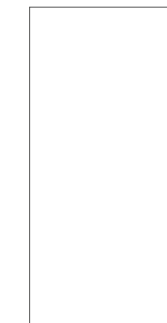

60x120
23⁵/₈"x47²/₈"



80x160
31¹/₈"x63"

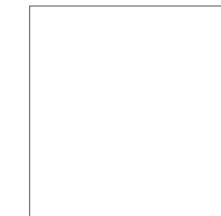

80x80
31¹/₈"x31¹/₈"

MATT RT

9 mm



60x120
23⁵/₈"x47²/₈"

*La liste a jour des produits et formats des series certifiees QB-UPEC est disponible en usine.

Anima Ever

MARBLE LOOK

La gamma

The range

MAGNIFICENT WHITE

LUXURY ARABESQUE

APUAN GOLD

SAGE GREEN

ROYAL ONYX

LUCIDATO RT

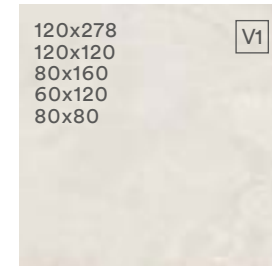
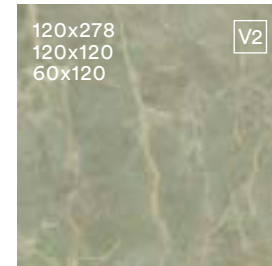
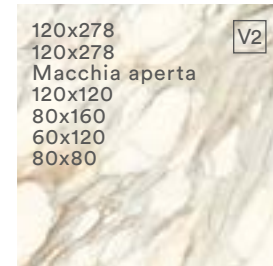
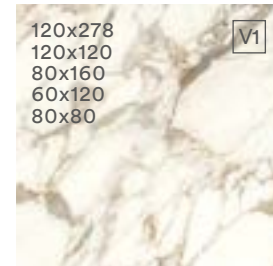

SILK RT

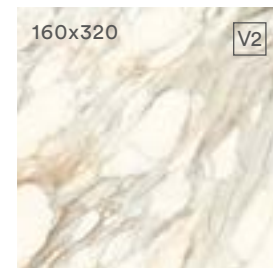

MATT RT

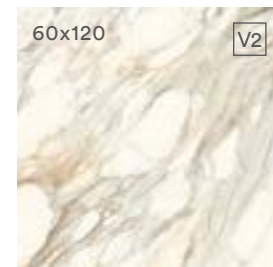

RT Rettificato, quadrato, monocalibro. - Rectified, squared, one caliber. - Rectifié, mis d'équerre et monocalibre. - Rektifiziert, rechtwinkelig und Ein kaliber. - Ректифицированный, одного калибра.

Anima Ever

MARBLE LOOK

Macchia aperta

Bookmatch

APUAN GOLD

120x278 cm . 47²/₈"x109⁷/₁₆" LUCIDATO RT

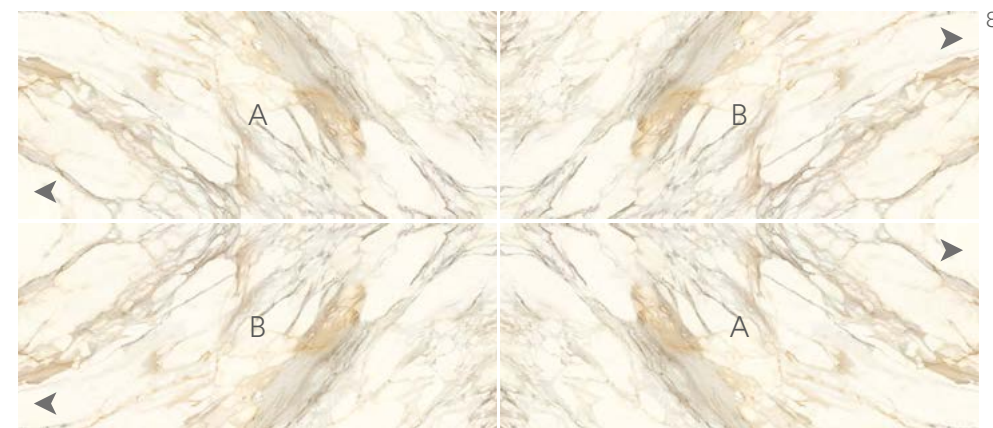
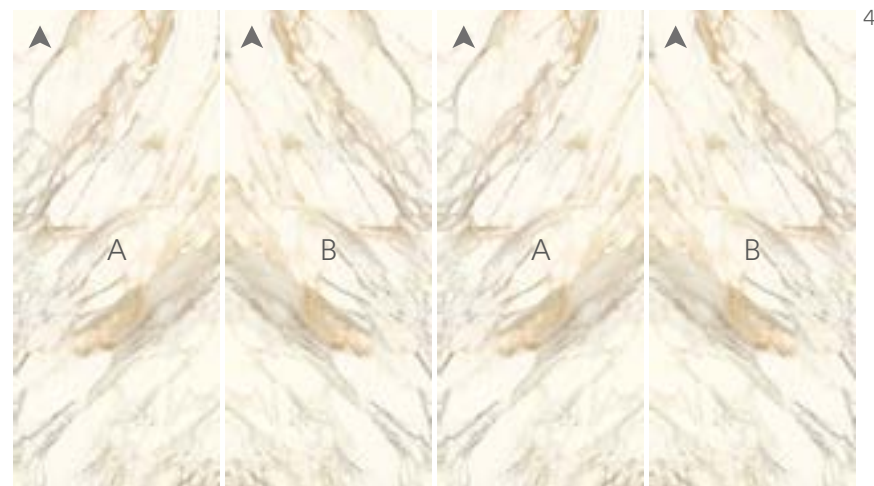
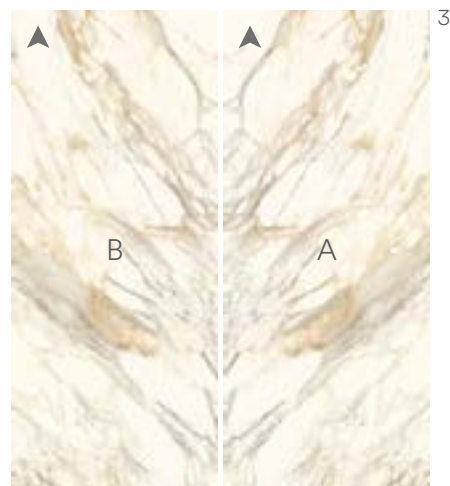
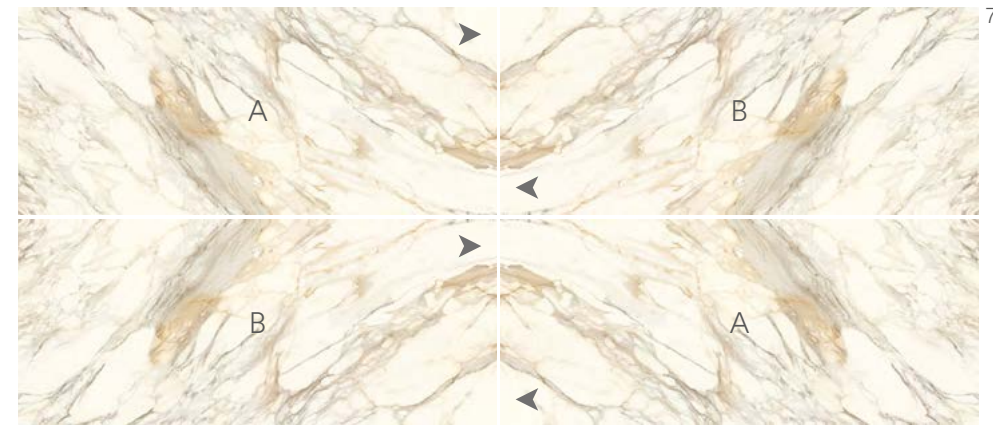
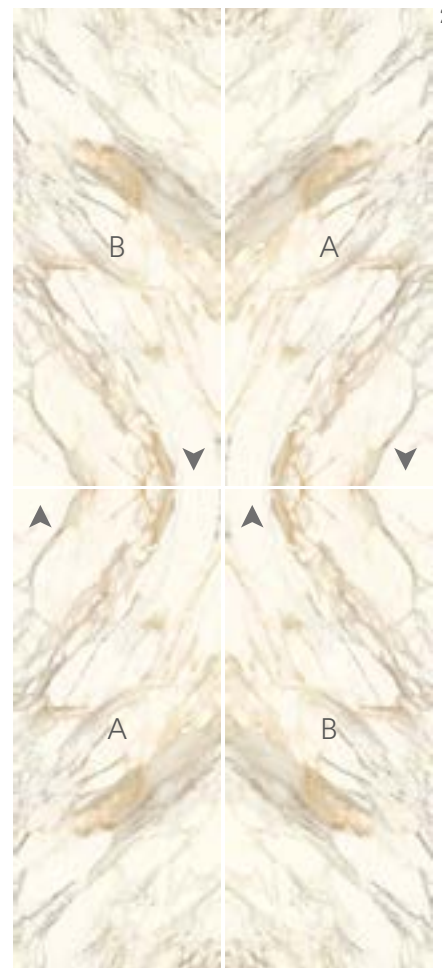
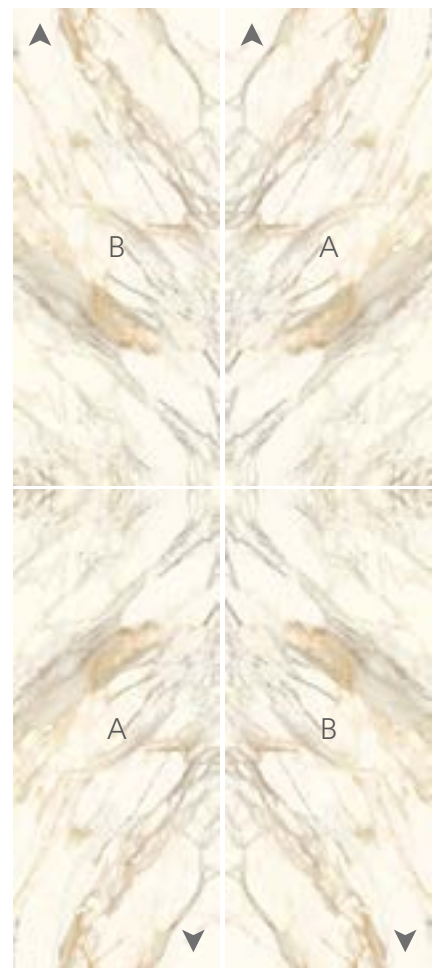

Suggerimenti di posa. Installation suggestions
Suggestions pour la pose. Verlegetipps
Рекомендации по укладке

RT Rettificato, squadrato, monocalibro. - Rectified, squared, one caliber. - Rectifié, mis d'équerre et monocalibre. - Rektifiziert, rechtwinkelig und Ein kaliber. - Ректифицированный, одного калибра.

Le lastre potrebbero presentare minimi disallineamenti tra le venature in continuità: ciò è da intendersi come caratteristica intrinseca del prodotto.
There may be minor misalignments of continuous veins: this is to be considered as an intrinsic feature of the product.
Les dalles peuvent présenter de faibles écarts de continuité des veines : ceci est une caractéristique intrinsèque du produit.
Die Platten können unter den durchgehenden Äderungen minimale Fluchtungsabweichungen aufweisen: dies ist ein charakteristisches Merkmal des Produkts.
У плит может наблюдаться минимальная нестыковка сплошного рисунка, которая должна считаться особенностью изделия.

Anima Ever

MARBLE LOOK

Continuità di vena

Continuous veins

APUAN GOLD 160x320 cm . 63"x126" SILK RT | 120x278 cm . 47²/₈"x109⁷/₁₆" LUCIDATO RT



LUXURY ARABESQUE 120x278 cm . 47²/₈"x109⁷/₁₆" LUCIDATO RT



MAGNIFICENT WHITE 120x278 cm . 47²/₈"x109⁷/₁₆" LUCIDATO RT



RT Rettificato, quadrato, monocalibro. - Rectified, squared, one caliber. - Rectifié, mis d'équerre et monocalibre. - Rektifiziert, rechtwinkelig und Ein kaliber. - Ректифицированный, одного калибра.

Decori

Decors

COMPOSIZIONE F 30x30 cm . 11¹³/₁₆"x11¹³/₁₆" LUCIDATO



LUXURY ARABESQUE

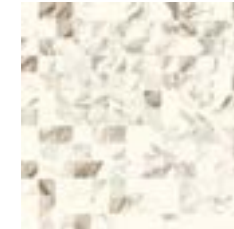

APUAN GOLD

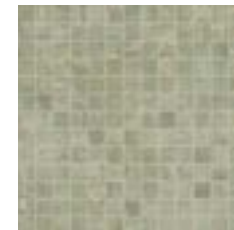

SAGE GREEN



ROYAL ONYX

COMPOSIZIONE ESAGONO 28,5X33 cm . 11³/₁₆"x13" LUCIDATO



LUXURY ARABESQUE



APUAN GOLD



SAGE GREEN



ROYAL ONYX

Continuità di vena / Continuous veins

Essendo l'inserimento delle lastre nelle confezioni casuale, Caesar non garantisce a priori le tipologie di facce presenti all'interno di ogni singola confezione. Le lastre potrebbero presentare minimi disallineamenti tra le venature in continuità: ciò è da intendersi come caratteristica intrinseca del prodotto.

Since slabs are packaged in a random manner, Caesar cannot guarantee the type of faces inside each package. There may be minor misalignments of continuous veins: this is to be considered as an intrinsic feature of the product.

L'introduction des dalles dans les emballages étant casuelle, Caesar ne garantit pas a priori les typologies de faces présentes dans chaque emballage. Les dalles peuvent présenter de faibles écarts de continuité des veines : ceci est une caractéristique intrinsèque du produit.

Da die Platten nach dem Zufallsprinzip verpackt werden, kann Caesar die in jeder einzelnen Verpackung enthaltenen Varianten der Oberflächengrafik nicht garantieren. Die Platten können unter den durchgehenden Äderungen minimale Fluchtungsabweichungen aufweisen: dies ist ein charakteristisches Merkmal des Produkts.

Поскольку плиты упаковываются в произвольном порядке, Caesar не дает никаких предварительных гарантий по типу рисунка, имеющегося в каждой отдельной упаковке. У плит может наблюдаться минимальная нестыковка сплошного рисунка, которая должна считаться особенностью изделия.

CARATTERISTICHE TECNICHE

TILE PERFORMANCE DATA - NOTES TECHNIQUES - TECHNISCHE AUSKÜNFTE - ТЕХНИЧЕСКАЯ ХАРАКТЕРИСТИКА

Classificazione secondo EN ISO 14411 ISO 13006 annesso G gruppo Bla con Ev ≤0,5% - Classification in accordance with EN ISO 14411 ISO 13006 annex G standards Bla with Ev ≤ 0,5% - Classification selon EN ISO 14411 ISO 13006 annexe G groupe Bla avec Ev ≤0,5% - Klassifizierung gemäß EN ISO 14411 ISO 13006 anlage G Gruppe Bla mit Ev ≤0,5% - Классификация в соответствии с EN ISO 14411 ISO 13006, приложение G, стандарт Bla, где Ev ≤0,5%

| Formato | Dimensione | Spessore | Finitura | Slip |
|-------------------|--------------------------------|----------|-------------|------|
| Magnificent White | 160x320 cm (63"x126") | 6 mm | SILK RT | |
| Luxury Arabesque | 120x278 cm (47 1/8"x109 7/16") | 6 mm | LUCIDATO RT | ● |
| Apuan Gold | 120x120 cm (47 1/8"x47 1/8") | 9 mm | LUCIDATO RT | ● |
| Sage Green | 80x160 cm (31 1/8"x63") | 9 mm | LUCIDATO RT | ● |
| Royal Onyx | 60x120 cm (23 5/8"x47 1/8") | 9 mm | LUCIDATO RT | ● |
| | 80x80 cm (31 1/8"x31 1/8") | 9 mm | LUCIDATO RT | ● |

| Formato | Dimensione | Spessore | Finitura | Slip |
|------------------|------------------------------|----------|-------------|------|
| Luxury Arabesque | 7,2x80 cm (2 13/16"x31 1/8") | 6 mm | LUCIDATO RT | ● |
| Apuan Gold | 7,2x60 cm (2 13/16"x23 5/8") | 6 mm | LUCIDATO RT | ● |
| Sage Green | 33x120 cm (13"x47 1/8") | 9 mm | LUCIDATO RT | ● |
| Royal Onyx | 33x33 cm (13"x13") | 9 mm | LUCIDATO RT | ● |

| IMBALLI - PACKAGING - CONDITIONNEMENT - VERPACKUNGS-EINHEITEN - УПАКОВКА | | | | | | | |
|--------------------------------------------------------------------------|-------------------|------------------------------------------|--------|--------|---------------------------|-------|----------|
| Formato - Size - Format - Формат | | Scatola - Box - Boîte - Karton - Коробка | | | Pallet - Palette - Палета | | |
| CM | INCHES | PZ | MQ | KG | SC | MQ | KG |
| 160x320 | 63"x126" | 1 | 5,12 | -78,00 | 14 | 71,68 | -1092,00 |
| 120x278 | 47 1/8"x109 7/16" | 1 | 3,3221 | -49,56 | 18 | 59,79 | -892,08 |
| 120x120 | 47 1/8"x47 1/8" | 2 | 2,856 | -62,00 | 20 | 57,12 | -1240,00 |
| 80x160 | 31 1/8"x63" | 2 | 2,56 | -50,50 | 16 | 40,96 | -808,00 |
| 60x120 | 23 5/8"x47 1/8" | 2 | 1,44 | -32,00 | 35 | 50,40 | -1120,00 |
| 80x80 LUCIDATO | 31 1/8"x31 1/8" | 2 | 1,28 | -27,36 | 42 | 53,76 | -1149,12 |

RT Rettificato, squadrato, monocalibro. - Rectified, squared, one caliber. - Rectifié, mis d'equerre et monocalibre. - Rektifiziert, rechteckig und Ein kaliber. - Ректифицированный, одна калибра.
 ** Disponibile solo su richiesta. - Manufactured only upon special request. - Seulement sur demande. - Nur auf Anfrage. - Производится только по заказу.

L'utilizzo della finitura LUCIDATO e SILK è limitato ai rivestimenti e alla posa a pavimento in ambito residenziale, o comunque in aree scarsamente sollecitate, evitando in ogni caso il contatto diretto con aree esterne o nelle quali siano richieste prestazioni antiscivolo. Le finiture LUCIDATO e SILK sono il risultato di particolari lavorazioni meccaniche e possono presentare occasionali puntature e avvallamenti, così come disuniformità nella lucentezza. Tali peculiarità sono da intendersi come caratteristiche integranti dei prodotti, allo scopo di ottenere una maggiore naturalezza. - The use of the LUCIDATO and SILK finishes is limited to wall cladding and floor application in residential venues and in spaces subject to low foot traffic, avoiding the direct contact with outdoor areas which require anti-slip features. The LUCIDATO and SILK finishes are the result of a special mechanical process and can manifest small dots or hollows as well as a non-uniform shine all over the surface. These particularities are to be considered as intrinsic features of the product which give them a more natural appeal. - Utilisation de la finition LUCIDATO et SILK est limitée aux revêtements et à la pose au sol dans des environnements résidentiels, ou dans tous les cas dans des aires faiblement sollicitées, en évitant ainsi le contact direct avec les aires extérieures ou dans lesquelles sont requises des prestations antidérapantes. Les finitions LUCIDATO et SILK sont le résultat de façonnages mécaniques particuliers et peuvent présenter d'éventuelles petites taches ou de légers affaissements ou bien des différences de brillance. Ces particularités doivent être considérées comme des caractéristiques du produit à part entière. Le façonnage de cette finition a justement pour but d'obtenir cet effet naturel et différé. - Die Verwendung der Version LUCIDATO und SILK ist auf Wand und Boden im Wohnbereich bzw. in wenig belasteten Bereichen beschränkt, und in jedem Fall ist der direkte Kontakt mit Außenbereichen sowie mit Rutschfestigkeit erfordernden Bereichen zu vermeiden. Die Versionen LUCIDATO und SILK sind Ergebnisse besonderer maschineller Bearbeitungen; sie können gelegentlich Nadelstiche und Krater sowie uneinheitlichen Glanz aufweisen. Es handelt sich hierbei um Produktmerkmale, mit denen eine besonders natürliche Wirkung erzeugt wird. - Плитки с поверхностью LUCIDATO и SILK можно укладывать только на стены и полы в жилых помещениях или, во всяком случае, в контекстах, где покрытие подвергается невысокой эксплуатационной нагрузке. Не рекомендуется укладывать их на улице или на участках, где от покрытия требуется высокое сопротивление скольжению. Поверхности LUCIDATO и SILK получают в результате специальной механической обработки и могут иметь небольшие сколы, углубления или неравномерный блеск. Эти особенности являются характерной чертой изделий и имеют целью придать им большую натуральность.

Si raccomanda l'utilizzo di una fuga di 2/3 mm al fine di semplificare le operazioni di posa e ottimizzare la naturalezza del risultato finale. - We recommend you a 2/3 mm grout joint to simplify the laying and optimize the naturalness of the final result. - Un joint de 2/3 mm est conseillé afin de simplifier les opérations de pose et optimiser l'effet naturel du résultat final. - Es wird empfohlen mit einer Fuge von 2/3 mm zu arbeiten, um am Ende den Verlegevorgang zu vereinfachen und die bestmögliche Natürlichkeit der Arbeit zu erzielen. - Для облегчения операций укладки и повышения натуральности вида конечного результата рекомендуется выполнять шов шириной 2-3 мм.

Al fine di facilitare la manutenzione ordinaria si raccomanda di effettuare un lavaggio acido dopo 48 ore dalla stuccatura con un acido specifico per grès porcellanato. - In order to favour the ordinary maintenance procedures, it is recommended to carry out an acid wash of the surface after 48 hours from grout filling using an acid agent specific for porcelain stoneware tiles. Afin de faciliter l'entretien ordinaire de votre carrelage, nous vous conseillons de le laver 48 heures après le colmatage des joints, avec un acide spécifique pour grès cérame. Um die Instandhaltung zu erleichtern, empfiehlt es sich 48 Stunden nach der Stuckatur mit einer sauren Lösung speziell für Feinsteinzeug zu waschen. - Чтобы упростить уход за плиткой, спустя 48 часов после затирки швов рекомендуется выполнить обработку кислотным продуктом, пригодным для керамогранита.

| | CARATTERISTICA TECNICA TECHNICAL CHARACTERISTIC CARACTERISTIQUE TECHNIQUE TECHNISCHE DATEN ТЕХНИЧЕСКАЯ ХАРАКТЕРИСТИКА | METODO DI PROVA TESTS METHOD METHODE D'ESSAI TESTMETHODE МЕТОД ИСПЫТАНИЯ | VALORE * MEDIO "CAESAR" AVERAGE "CAESAR" VALUE * VALEUR * MOYEN "CAESAR" "CAESAR" DURCHSCHNITTSWERT * СРЕДНЕЕ ЗНАЧЕНИЕ "CAESAR" * | | |
|--|--------------------------------------------------------------------------------------------------------------------------------------------------------------------------------------------------------------------------------------------|--------------------------------------------------------------------------------------|-----------------------------------------------------------------------------------------------------------------------------------------------|-------------------------------------------------------------------------|-------------------------------------------------------------------------|
| | | | Lucidato | Silk | Matt |
| | Dimensione - Size Dimension - Abmessungen - Размер | ISO 10545-2 | Conforme - In accordance Conforme - Erfüllt - Соответствует | Conforme - In accordance Conforme - Erfüllt - Соответствует | Conforme - In accordance Conforme - Erfüllt - Соответствует |
| | Assorbimento d'acqua* - Water absorption* Absorption d'eau* - Wasseraufnahme* - % Поглощения воды* | ISO 10545-3 | ≤ 0,1% | ≤ 0,1% | ≤ 0,1% |
| | Resistenza alla flessione* - Bending strength* Résistance à la flexion* - Biegezugfestigkeit* - Упругость* | ISO 10545-4 | Conforme - In accordance Conforme - Erfüllt - Соответствует | Conforme - In accordance Conforme - Erfüllt - Соответствует | Conforme - In accordance Conforme - Erfüllt - Соответствует |
| | Resistenza all'urto - Impact resistance Résistance au choc - Schlagfestigkeit - Ударопрочность | ISO 10545-5 | ≥ 0,80 | ≥ 0,80 | ≥ 0,80 |
| | Resistenza all'abrasione profonda* - Deep scratch resistance* Résistance à l'abrasion profonde* - Widerstand gegen Tiefenverschleiß* Устойчивость глубокому истиранию* | ISO 10545-6 | - | Conforme - In accordance Conforme - Erfüllt - Соответствует | Conforme - In accordance Conforme - Erfüllt - Соответствует |
| | Coefficiente di dilatazione termica lineare* - Thermal linear expansion coefficient* Coefficient de dilatation thermique linéaire* - Koeffizient der linearen thermischen Dehnung* - Коэффициент линейного теплового расширения* | ISO 10545-8 | ≈ 7 (10 ⁻⁶ °C ⁻¹) | ≈ 7 (10 ⁻⁶ °C ⁻¹) | ≈ 7 (10 ⁻⁶ °C ⁻¹) |
| | Resistenza agli sbalzi termici* - Thermal shock resistance* Résistance aux écarts de température* - Temperaturwechsel Beständigkeit* Устойчивость к тепловому перепаду* | ISO 10545-9 | Conforme - In accordance Conforme - Erfüllt - Соответствует | Conforme - In accordance Conforme - Erfüllt - Соответствует | Conforme - In accordance Conforme - Erfüllt - Соответствует |
| | Dilatazione all'umidità* - Expansion in humidity* Dilatation à l'humidité* - Feuchtigkeitsausdehnung* Расширение в условиях влажности* | ISO 10545-10 | Conforme - In accordance Conforme - Erfüllt - Соответствует | Conforme - In accordance Conforme - Erfüllt - Соответствует | Conforme - In accordance Conforme - Erfüllt - Соответствует |
| | Resistenza al cavillo - Cracking resistance Résistance aux craquelures - Haariß-Beständigkeit Устойчивость эмали к краquelору | ISO 10545-11 | Conforme - In accordance Conforme - Erfüllt - Соответствует | - | - |
| | Resistenza al gelo* - Frost resistance* Résistance au gel* - Frostbeständigkeit* - Морозоустойчивость* | ISO 10545-12 | Resistente - Resistant Résistante - Beständig - Стойкий | Resistente - Resistant Résistante - Beständig - Стойкий | Resistente - Resistant Résistante - Beständig - Стойкий |
| | Resistenza all'attacco chimico* - Resistance to chemical attack* Résistance à l'attaque chimique* - Beständigkeit gegen Chemikalien* Устойчивость к химическому воздействию* | ISO 10545-13 | Resistente - Resistant Résistante - Beständig - Стойкий | Resistente - Resistant Résistante - Beständig - Стойкий | Resistente - Resistant Résistante - Beständig - Стойкий |
| | Resistenza alle macchie* - Resistance to stains* Résistance aux taches* - Fleckenbeständigkeit* Устойчивость к образованию пятен* | ISO 10545-14 | Pulibile - Cleanable Nettoyable - Leicht zu reinigen - Чистящийся | Pulibile - Cleanable Nettoyable - Leicht zu reinigen - Чистящийся | Pulibile - Cleanable Nettoyable - Leicht zu reinigen - Чистящийся |
| | Resistenza allo scivolamento** - Slip resistance** Résistance au glissement** - Rutschhemmende Eigenschaft** Сопротивление скольжению** | DIN 51130 - DIN 51097 ▲ ANSI A326.3 | - | - | R9 Matt Wet DCOF ≥ 0,42 |
| | Resistenza all'abrasione superficiale - Surface abrasion resistance Résistance à l'abrasion superficielle - Widerstand gegen Oberflächenschleiß* Сопротивление на изгиб и усилию на излом | EN ISO 10545-7 | - | - | - |
| | Durezza Mohs - Mohs hardness Dureté Mohs - Ritzhärte nach Mohs - Устойчивость к изгибу | EN 101 | Coeff. 5 | Coeff. 6 | Coeff. 6 |
| | Spessore nominale - Nominal Thickness Epaisseur nominal - Nominalstärke Номинальная толщина | | 6 mm 160x320 - 120x278 | 6 mm | 9 mm |

* Valori medi riferiti agli ultimi due anni di produzione e relativi alla finitura naturale del prodotto - Average values referred to the last two years of production and related to the matt finish of the product - Valeurs moyennes des deux dernières années de production et relatives à la finition naturelle du produit - Durchschnittswerte, die sich auf die letzten zwei Produktionsjahre beziehen und auf die matte Oberflächfläche - Средние значения относятся к последним двум годам производства и натуральной отделке поверхности

** Valori relativi alla finitura naturale del prodotto ed a test effettuati da laboratori esterni accreditati, disponibili in azienda; ci rendiamo disponibili alla verifica dell'eventuale lotto interessato all'acquisto. - As far as values relating to the matt finish of the product and to tests carried out by certified external laboratories whose results are available upon request at Headoffice, we are willing to check the lot you are interested in purchasing. - Valeurs se référant à la finition naturelle du produit selon des tests effectués par des laboratoires extérieurs accrédités et à la disposition de toute personne intéressée auprès de nos bureaux; nous sommes disponibles pour le contrôle de l'éventuel lot concerné par l'achat. - Werte bezogen auf das natürliche Produktfinish und in anerkannten externen Labors geprüft, im Unternehmen erhältlich; für eventuelle Prüfungen der zu erwerbenden Warenposten stehen wir gern zur Verfügung. - Значения, касающиеся натуральных характеристик изделий и тестов, выполненных внешними авторизованными лабораториями, имеются в компании. Мы готовы выполнить проверку партии товара, которую намереваетесь приобрести.

• Per prodotti chimici di uso domestico e additivi per piscina. - For domestic chemicals and swimming pool additives. - Pour produits chimiques à usage domestique et additifs pour piscines. - Für chemische Produkte für den Hausgebrauch und Schwimmbadzusätze. - Для бытовых химикатов и добавок для бассейнов.

▲ Valori wet DCOF specifici disponibili in azienda - Wet DCOF specific values available at the company - Valeurs wet DCOF spécifiques disponibles à l'usine - Prüferte Wet DCOF stehen im Werk zur Verfügung - Показатели wet DCOF доступны при запросе

Le tonalità dei campioni sono da considerarsi puramente indicative. - Tones of samples are indicative. - Les tonalités des échantillons sont purement indicatives. Die farbtoner der Muster sind als rein indicativ zu betrachten. - Тона образцов ориентировочные.

Anima Futura

A vision of elegance



Anima Futura rinnova la percezione del look marmo, accostandolo a forme geometriche, colori accesi, arredi essenziali o preziosi; ispira con accostamenti tra i suoi colori o con eclettici abbinamenti di materiali. Con Anima Futura, il grès di Caesar illumina la grande bellezza del marmo suggerendo uno stile proiettato nel futuro.

Anima Futura renews the perception of marble, combining it with geometric shapes, bright colours, understated or prized furnishing; it is a source of inspiration with combinations of colour or eclectic material pairings. With Anima Futura, Caesar porcelain stoneware lights up the radiant beauty of marble suggesting a trendy style with a keen eye on the future.

Anima Futura propose une nouvelle perception du marbre, mariant les formes géométriques, les couleurs vives, les ameublements essentiels ou précieux. La collection inspire avec ses couleurs variées ou ses associations éclectiques de matériaux. Avec Anima Futura, le grès de Caesar illumine la grande beauté du marbre suggérant un style actuel et tourné vers le futur.

Anima Futura stimuliert eine neue Wahrnehmung des Marmors, durch Kombination mit geometrischen Formen, leuchtenden Farben, schlichtem oder kostbarem Mobiliar. Und inspiriert dazu, mehrere Farben zu mixen oder auch eklektisch Materialien zu kombinieren. Mit Anima Futura leuchtet das Feinsteinzeug von Caesar die bestechende Schönheit des Marmors auf originelle Weise aus und suggeriert einen höchst aktuellen, zukunftsgerichteten Stil.

Anima Futura предлагает новое видение мрамора, сочетая его с геометрическими формами, яркими цветами, сдержанной или изысканной мебелью. Она вдохновляет сочетаниями представленных в ней цветов и комбинациями материалов Anima Futura от марки Caesar оригинально раскрывает всю красоту мрамора, предлагая крайне актуальный стиль для интерьеров будущего.



Info
Resources
Tools

MARBLE LOOK



Floor: **GOLDEN WHITE 120x120 LUCIDATO RT**,
Wall: **KEEN GREY 60x120 LUCIDATO RT**, **KEEN GREY COMPOSIZIONE F 30x30 LUCIDATO RT**, **GOLDEN WHITE 120x278 LUCIDATO RT**
Furniture by **OLOS: KEEN GREY 120x278 LUCIDATO RT**

Anima Futura



MARBLE LOOK

Colori - Formati

Colors - Sizes

120x278 6 mm LUCIDATO RT
 120x120 . 60x120 . 80x80 . 60x60 . 30x60 9 mm LUCIDATO RT
 60x120 . 60x60 . 30x60 9 mm MATT RT

GOLDEN WHITE



KEEN GREY



MAJESTIC WHITE



CRYSTAL DELIGHT



AMAZING SILVER



PINK ONYX



UNIQUE BLACK



*La liste à jour des produits et formats des series certifiées QB-UPEC est disponible en usine.

6 mm

LUCIDATO RT

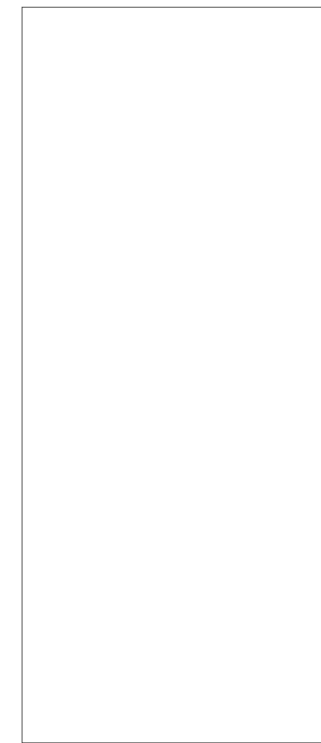

120x278
 47²/₈"x109⁷/₁₆"

9 mm

LUCIDATO RT

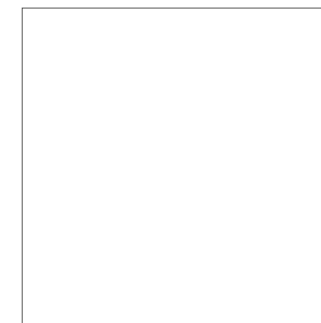

120x120
 47²/₈"x47²/₈"

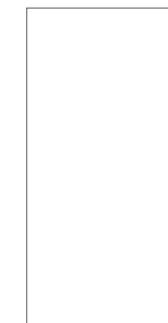

60x120
 23⁵/₈"x47²/₈"



80x80
 31¹/₈"x31¹/₈"



60x60
 23⁵/₈"x23⁵/₈"



30x60
 11³/₁₆"x23⁵/₈"

9 mm

MATT RT



60x120
 23⁵/₈"x47²/₈"

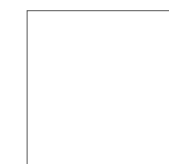

60x60
 23⁵/₈"x23⁵/₈"







30x60
 11³/₁₆"x23⁵/₈"

Anima Futura

MARBLE LOOK

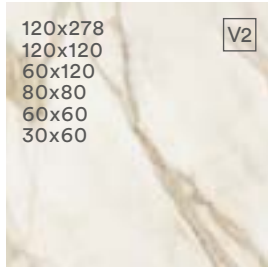
La gamma

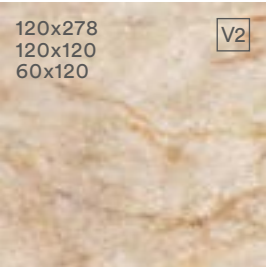
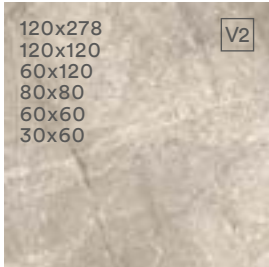
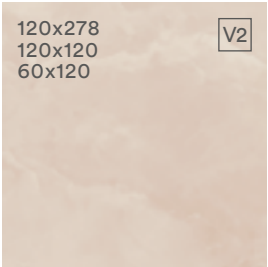
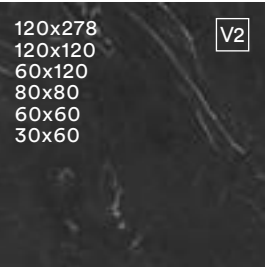
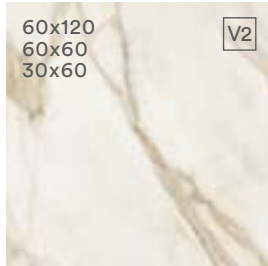
The range

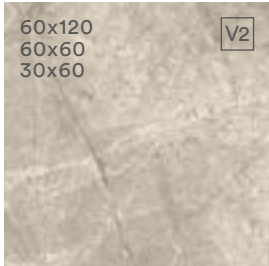
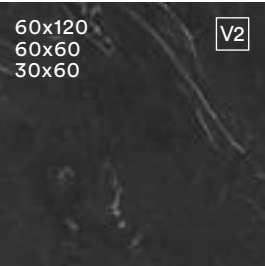
| | GOLDEN WHITE | KEEN GREY | MAJESTIC WHITE | CRYSTAL DELIGHT | AMAZING SILVER | PINK ONYX | UNIQUE BLACK |
|-------------|-------------------------------------------------------------------------------------------------------------------------------------------------------|-------------------------------------------------------------------------------------------------------------------------|--------------------------------------------------------------------------------------------------------------------------------------------------------|---------------------------------------------------------------------------------------------------------------------------|---------------------------------------------------------------------------------------------------------------------------------------------------------|---------------------------------------------------------------------------------------------------------------------------|---------------------------------------------------------------------------------------------------------------------------------------------------------|
| LUCIDATO RT |  <p>120x278 120x120 60x120 80x80 60x60 30x60</p> |  <p>120x278 120x120 60x120</p> |  <p>120x278 120x120 60x120 80x80 60x60 30x60</p> |  <p>120x278 120x120 60x120</p> |  <p>120x278 120x120 60x120 80x80 60x60 30x60</p> |  <p>120x278 120x120 60x120</p> |  <p>120x278 120x120 60x120 80x80 60x60 30x60</p> |
| MATT RT |  <p>60x120 60x60 30x60</p> | |  <p>60x120 60x60 30x60</p> | |  <p>60x120 60x60 30x60</p> | |  <p>60x120 60x60 30x60</p> |

RT Rettificato, quadrato, monocalibro. - Rectified, squared, one caliber. - Rectifié, mis d'équerre et monocalibre. - Rektifiziert, rechtwinkelig und Ein kaliber. - Ректифицированный, одного калибра.



Vein Match

Su sei colori della gamma Anima Futura sono disponibili i set Vein Match, singoli articoli composti da 4 o 5 lastre in formato 120x278 cm. Questa proposta garantisce un effetto sequenziale a vena continua dall'effetto estetico altamente suggestivo.

Vein Match sets are available on six colours in the Anima Futura range, individual items consisting of 4 or 5 slabs in 120x278 cm size. This proposal guarantees a sequential continuous vein effect with a highly suggestive aesthetic effect.

Les ensembles Vein Match, des articles simples composés de 4 ou 5 dalles au format 120x278 cm, sont disponibles sur six couleurs de la gamme Anima Futura. Cette proposition garantit un effet séquentiel à veine continue avec un cachet esthétique très suggestif.

Für sechs Farben der Serie Anima Futura sind die aus jeweils 4 oder 5 Platten im Format 120x278 cm bestehenden Vein Match-Sets erhältlich. Diese garantieren mit ihrer durchgehenden Äderung einen höchst ansprechenden, sequenziellen Effekt.

В шести цветах гаммы Anima Futura доступны наборы Vein Match, где отдельные изделия состоят из 4 или 5 плит формата 120x278 см. Это предложение гарантирует эффект последовательных непрерывных прожилок с впечатляющим эстетическим эффектом.

VEIN MATCH GOLDEN WHITE 120x278 cm . 47²/₈"x109⁷/₁₆" LUCIDATO RT



VEIN MATCH MAJESTIC WHITE 120x278 cm . 47²/₈"x109⁷/₁₆" LUCIDATO RT



VEIN MATCH AMAZING SILVER 120x278 cm . 47²/₈"x109⁷/₁₆" LUCIDATO RT



RT Rettificato, squadrato, monocalibro.
Rectified, squared, one caliber.
Rectifié, mis d'équerre et monocalibre.
Rektifiziert, rechtwinkelig und Ein kaliber.
Ректифицированный, одного калибра.

VEIN MATCH UNIQUE BLACK 120x278 cm . 47²/₈"x109⁷/₁₆" LUCIDATO RT

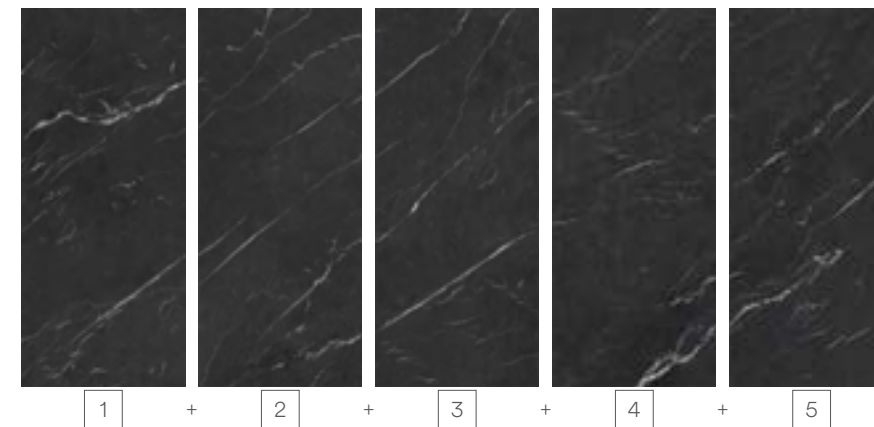

VEIN MATCH CRYSTAL DELIGHT 120x278 cm . 47²/₈"x109⁷/₁₆" LUCIDATO RT



VEIN MATCH KEEN GREY 120x278 cm . 47²/₈"x109⁷/₁₆" LUCIDATO RT

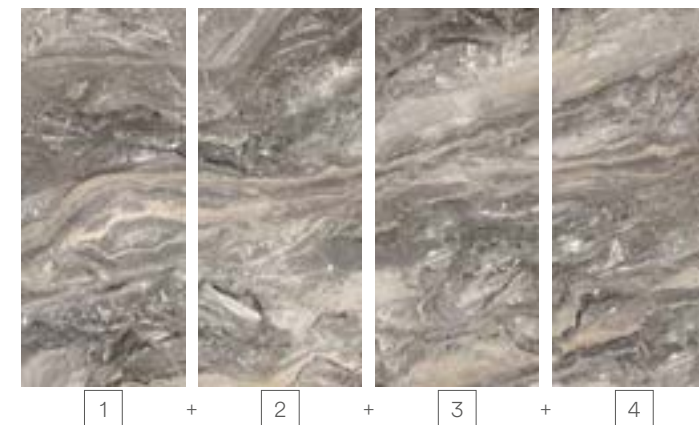

Vein Match è un set venduto in cassa e composto da tutte le lastre che caratterizzano il design del prodotto (4 o 5 come specificato caso per caso), con continuità di venatura. Le lastre potrebbero presentare minimi disallineamenti tra loro: ciò è da intendersi come caratteristica intrinseca del prodotto.

Vein Match is a set sold in a box and consists of all the slabs that characterise the product design (4 or 5 as specified in each case), with veining continuity. Slabs may have slight misalignments between them: this is to be understood as an intrinsic characteristic of the product.

Vein Match est un ensemble vendu en caisses et composé de toutes les dalles qui caractérisent le design du produit (4 ou 5 tel que spécifié au cas par cas), avec une continuité de veines. Les dalles pourraient présenter de très légers décalages : cela doit être considéré comme une caractéristique intrinsèque du produit.

Vein Match ist ein in Kisten verkauftes Set mit allen das Design des Artikels bildenden Platten (4 oder 5, wie jeweils angegeben), die durchgehend geädert sind. Minimale Fluchtungsabweichungen sind möglich: dies ist ein typisches Merkmal des Produkts.

Vein Match - это набор, продающийся в коробке и состоящий из всех тех плит, которые характерны для дизайна продукта (4 или 5, как указано в каждом конкретном случае), с непрерывностью рисунка вен. Плиты могут иметь небольшую несочетаемость между собой, которая должна расцениваться как неотъемлемая характеристика продукта.

Decori

Decors

COMPOSIZIONE F 30x30 cm . 11¹³/₁₆"x11¹³/₁₆" LUCIDATO



GOLDEN WHITE



MAJESTIC WHITE



AMAZING SILVER

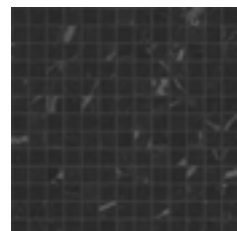

UNIQUE BLACK



KEEN GREY

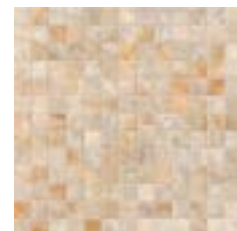

CRYSTAL DELIGHT

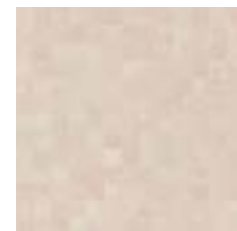

PINK ONYX

COMPOSIZIONE ESAGONO 28,5x33 cm . 11³/₁₆"x13" LUCIDATO



GOLDEN WHITE



MAJESTIC WHITE



AMAZING SILVER



UNIQUE BLACK



KEEN GREY



CRYSTAL DELIGHT



PINK ONYX

COMPOSIZIONE N BRASS 30x30 cm . 11¹³/₁₆"x11¹³/₁₆" LUCIDATO



GOLDEN WHITE



MAJESTIC WHITE



AMAZING SILVER



UNIQUE BLACK



KEEN GREY



CRYSTAL DELIGHT



PINK ONYX

GOLD MAGNOLIA 120x278 cm . 47²/₈"x109⁷/₁₆" LUCIDATO RT *



I decori **Gold Magnolia** in formato 120x278 sono realizzati tramite particolari applicazioni sulla superficie, successive alla cottura. Per la pulizia ordinaria, Caesar sconsiglia l'utilizzo di prodotti abrasivi, che potrebbero danneggiare la superficie; per evitare opacizzazioni o graffiature, si consiglia di eseguire la pulizia con un panno morbido e detersivi a PH neutro. In fase di posa del materiale, Caesar sconsiglia l'utilizzo di sistemi meccanici livellanti, che potrebbero causare danni alla superficie quando vengono rimossi. Prima di stuccare, si consiglia di proteggere la superficie nelle parti vicino al bordo con nastro adesivo per mascheratura; si raccomanda di utilizzare stucchi a base cementizia e non epossidica. Subito dopo la stuccatura, rimuovere gli eventuali residui con acqua e un panno morbido, senza l'utilizzo di spugne abrasive.

The **Gold Magnolia** 120x278 decorations were created using special surface applications after baking. For ordinary cleaning, Caesar advises to avoid abrasive products that could damage the surface. Cleaning with a soft cloth and neutral PH products is recommended to avoid dulling or scratching. When laying the material, Caesar recommends not to use mechanical levelling systems, which could cause damage to the surface when removed. Before grouting, it is advised to protect the surface in the parts near the edge with masking tape. Cement-based, not epoxy-based, grouts must be used. Immediately after grouting, remove any residues with water and a soft cloth, without using abrasive sponges.

Les décors **Gold Magnolia** 120x278 ont été réalisées grâce à des applications spéciales sur la surface, successives à la cuisson. Pour l'entretien ordinaire, Caesar déconseille d'utiliser des produits abrasifs, qui pourraient endommager la surface. Afin d'éviter opacification et rayures, il est conseillé d'effectuer le nettoyage à l'aide d'un chiffon souple et de produits au pH neutre. Lors de la pose du matériau, Caesar déconseille d'utiliser des systèmes mécaniques de nivellement, qui pourraient causer des dommages sur la surface lorsqu'on les retire. Avant le jointoiement, il est conseillé de protéger la surface aux endroits proches du bord à l'aide de ruban adhésif de masquage, et il est recommandé d'utiliser un mortier à base de ciment et non époxy. Tout de suite après le jointoiement, retirer les éventuels restes avec de l'eau et un chiffon souple, sans utiliser d'éponge abrasive.

Die Dekore **Gold Magnolia** 120x278 entstehen mit besonderen Applikationen nach dem Brennvorgang. Für die normale Reinigung rät Caesar von Scheuermitteln ab, da diese die Oberfläche beschädigen könnten. Um matte Stellen und Kratzer zu vermeiden, sollten zur Reinigung nur weiche Tücher und Produkte mit neutralem pH-Wert verwendet werden. Bei der Verlegung des Materials rät Caesar von mechanischen Nivelliermitteln ab, da die Oberfläche bei ihrer Entfernung Schaden nehmen könnte. Vor dem Verfugen sollte die Oberfläche an den Kanten abgeklebt werden; wir empfehlen zementhaltige Fugenmörtel und keine Epoxidharz- Fugenmassen. Eventuelle Rückstände sind sofort nach dem Verfugen mit einem trockenen Tuch und Wasser zu entfernen. Keine Scheuerschwämme verwenden.

Декоры **Gold Magnolia** 120x278 реализованы, после обжига, методом специального поверхностного нанесения. Компания Caesar рекомендует не использовать абразивные чистящие средства во избежание повреждения поверхности. Для предотвращения помутнения или появления царапин рекомендуется проводить очистку чистой ветошью и нейтральными моющими средствами. При укладке плитки компания Caesar не рекомендует использовать механические выравнивающие приспособления, способные повредить поверхность. Перед затиркой швов рекомендуется защитить края плитки малярным скотчем. Рекомендуется использовать затирочные составы на цементной, а не эпоксидной основе. После затирки швов необходимо удалить остатки материала мягкой ветошью и водой, не применяя абразивные губки.

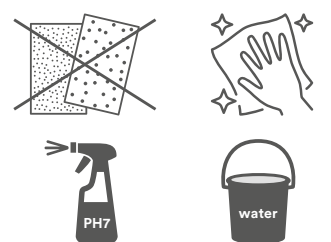

Realizzato su **Anima Futura** - Unique Black lucidato. - Made on **Anima Futura** - Unique Black polished. Fabriqu  sur **Anima Futura** - Unique Black poli. - Realisiert bei **Anima Futura** - Unique Black gl nzend. Realizovano na osnovu **Anima Futura** - Unique Black s polirovanom otdelkoy.

* Solo per rivestimento. - Only for wall application. - Exclusivement pour rev tement mural. - Nur als Wandverkleidung geeignet. - Только для облицовки.

I decori 120x278 Gold sono realizzati tramite applicazione da terzo fuoco di inchiostri a base oro. - The 120x278 Gold decorations are produced by third-firing application of gold-based inks. - Les d cors 120x278 Gold sont r alis s par application au troisi me feu d'encre s base d'or. - Die Dekore 120x278 Gold werden durch Auftragen von Golddruckfarben im Drittbrand hergestellt. - Д коры 120x278 Gold производятся методом третьего обжига с применением красок на золотой базе.

CARATTERISTICHE TECNICHE

TILE PERFORMANCE DATA - NOTES TECHNIQUES - TECHNISCHE AUSKÜNFTE - ТЕХНИЧЕСКАЯ ХАРАКТЕРИСТИКА

Classificazione secondo EN ISO 14411 ISO 13006 annesso G gruppo Bla con Ev ≤0,5% - Classification in accordance with EN ISO 14411 ISO 13006 annex G standards Bla with Ev ≤ 0,5% - Classification selon EN ISO 14411 ISO 13006 annexe G groupe Bla avec Ev ≤0,5% - Klassifizierung gemäß EN ISO 14411 ISO 13006 anlage G Gruppe Bla mit Ev ≤0,5% - Классификация в соответствии с EN ISO 14411 ISO 13006, приложение G, стандарт Bla, где Ev ≤0,5%

| | 120x278 cm 47 ⁷ / ₈ "x109 ⁷ / ₁₆ " 6 mm | 120x120 cm 47 ⁷ / ₈ "x47 ⁷ / ₈ " 9 mm | 60x120 cm 23 ⁵ / ₈ "x47 ⁷ / ₈ " 9 mm | 80x80 cm 31 ¹ / ₈ "x31 ¹ / ₈ " 9 mm | 60x60 cm 23 ⁵ / ₈ "x23 ⁵ / ₈ " 9 mm | 30x60 cm 11 ¹⁵ / ₁₆ "x23 ⁵ / ₈ " 9 mm |
|-----------------|-------------------------------------------------------------------------------------------|-----------------------------------------------------------------------------------------|----------------------------------------------------------------------------------------|---------------------------------------------------------------------------------------|---------------------------------------------------------------------------------------|-----------------------------------------------------------------------------------------|
| | LUCIDATO RT | LUCIDATO RT | LUCIDATO RT MATT RT | LUCIDATO RT | LUCIDATO RT MATT RT | LUCIDATO RT MATT RT |
| Golden White | ● | ● | ● ● | ● | ● | ● ● |
| Majestic White | ● | ● | ● ● | ● | ● | ● ● |
| Amazing Silver | ● | ● | ● ● | ● | ● | ● ● |
| Unique Black | ● | ● | ● ● | ● | ● | ● ● |
| Keen Grey | ● | ● | ● ● | ● | ● | ● ● |
| Crystal Delight | ● | ● | ● ● | ● | ● | ● ● |
| Pink Onyx | ● | ● | ● ● | ● | ● | ● ● |

| | 7,2x80 cm 2 ¹⁵ / ₁₆ "x31 ¹ / ₈ " | 7,2x60 cm 2 ¹⁵ / ₁₆ "x23 ⁵ / ₈ " | 33x120 cm 13"x47 ⁷ / ₈ " | 33x33 cm 13"x13" |
|-----------------|---------------------------------------------------------------------------------|---------------------------------------------------------------------------------|---------------------------------------------------|---------------------|
| | LUCIDATO | LUCIDATO MATT | LUCIDATO MATT | LUCIDATO MATT |
| Golden White | ● | ● ● | ● ● | ● ● |
| Majestic White | ● | ● ● | ● ● | ● ● |
| Amazing Silver | ● | ● ● | ● ● | ● ● |
| Unique Black | ● | ● ● | ● ● | ● ● |
| Keen Grey | ● | ● ● | ● ● | ● ● |
| Crystal Delight | ● | ● ● | ● ● | ● ● |
| Pink Onyx | ● | ● ● | ● ● | ● ● |

IMBALLI - PACKAGING - CONDITIONNEMENT - VERPACKUNGS-EINHEITEN - УПАКОВКА

| Formato - Size - Format - Формат | | Scatola - Box - Boîte - Karton - Коробка | | | Pallet - Palette - Палета | | |
|----------------------------------|---------------------------------------------------------------------|------------------------------------------|--------|--------|---------------------------|--------|-----------|
| CM | INCHES | PZ | MQ | KG | SC | MQ | KG |
| 120x278 | 47 ⁷ / ₈ "x109 ⁷ / ₁₆ " | 1 | 3,3221 | -49,56 | 18 | 59,79 | -892,08 |
| 120x120 | 47 ⁷ / ₈ "x47 ⁷ / ₈ " | 2 | 2,8561 | -62,00 | 20 | 57,122 | -1240,00 |
| 60x120 | 23 ⁵ / ₈ "x47 ⁷ / ₈ " | 2 | 1,44 | -32,00 | 35 | 50,40 | -1120,00 |
| 80x80 | 31 ¹ / ₈ "x31 ¹ / ₈ " | 2 | 1,28 | -27,36 | 48 | 61,44 | -1.313,28 |
| 60x60 LUCIDATO | 23 ⁵ / ₈ "x23 ⁵ / ₈ " | 3 | 1,08 | -25,75 | 40 | 43,20 | -1030,00 |
| 60x60 MATT | 23 ⁵ / ₈ "x23 ⁵ / ₈ " | 4 | 1,44 | -28,40 | 30 | 43,20 | -852,00 |
| 30x60 LUCIDATO/MATT | 11 ¹⁵ / ₁₆ "x23 ⁵ / ₈ " | 7 | 1,26 | -25,00 | 40 | 50,40 | -1000,00 |

RT Rettificato, squadrato, monocalibro. - Rectified, squared, one caliber. - Rectifié, mis d'équerre et monocalibre. - Rektifiziert, rechteckig und Ein kaliber. - Ректифицированный, одного калибра.

** Disponibile solo su richiesta. - Manufactured only upon special request. - Seulement sur demande. - Nur auf Anfrage. - Производится только по заказу.

L'utilizzo della finitura LUCIDATO e SILK è limitato ai rivestimenti e alla posa a pavimento in ambito residenziale, o comunque in aree scarsamente sollecitate, evitando in ogni caso il contatto diretto con aree esterne o nelle quali siano richieste prestazioni antiscivolo. Le finiture LUCIDATO e SILK sono il risultato di particolari lavorazioni meccaniche e possono presentare occasionali puntature e avvallamenti, così come disuniformità nella lucentezza. Tali peculiarità sono da intendersi come caratteristiche integranti dei prodotti, allo scopo di ottenere una maggiore naturalezza. - The use of the LUCIDATO and SILK finishes is limited to wall cladding and floor application in residential venues and in spaces subject to low foot traffic, avoiding the direct contact with outdoor areas which require anti-slip features. The LUCIDATO and SILK finishes are the result of a special mechanical process and can manifest small dots or hollows as well as a non-uniform shine all over the surface. These particularities are to be considered as intrinsic features of the product which give them a more natural appeal. - L'utilisation de la finition LUCIDATO et SILK est limitée aux revêtements et à la pose au sol dans des environnements résidentiels, ou dans tous les cas dans des aires faiblement sollicitées, en évitant ainsi le contact direct avec les aires extérieures ou dans lesquelles sont requises des prestations antidérapantes. Les finitions LUCIDATO et SILK sont le résultat de façonnages mécaniques particuliers et peuvent présenter d'éventuelles petites taches ou de légers affaissements ou bien des différences de brillance. Ces particularités doivent être considérées comme des caractéristiques du produit à part entière. Le façonnage de cette finition a justé pour but d'obtenir cet effet naturel et diforme. - Die Verwendung der Version LUCIDATO und SILK ist auf Wand und Boden im Wohnbereich bzw. in wenig belasteten Bereichen beschränkt, und in jedem Fall ist der direkte Kontakt mit Außenbereichen sowie mit Rutschfestigkeit erforderlichen Bereichen zu vermeiden. Die Versionen LUCIDATO und SILK sind Ergebnisse besonderer maschineller Bearbeitungen; sie können gelegentlich Nadelstiche und Krater sowie uneinheitlichen Glanz aufweisen. Es handelt sich hierbei um Produktmerkmale, mit denen eine besonders natürliche Wirkung erzeugt wird. - Плитки с поверхностью LUCIDATO и SILK можно укладывать только на стены и полы в жилых помещениях или, во всяком случае, в контекстах, где покрытие подвергается невысокой эксплуатационной нагрузке. Не рекомендуется укладывать их на улице или на участках, где от покрытия требуется высокое сопротивление скольжению. Поверхности LUCIDATO и SILK получаются в результате специальной механической обработки и могут иметь небольшие сколы, углубления или неравномерный блеск. Эти особенности являются характеристикой изделий и имеют целью придать им большую натуральность.

Si raccomanda l'utilizzo di una fuga di 2/3 mm al fine di semplificare le operazioni di posa e ottimizzare la naturalezza del risultato finale. - We recommend you a 2/3 mm grout joint to simplify the laying and optimize the naturalness of the final result. - Un joint de 2/3 mm est conseillé afin de simplifier les opérations de pose et optimiser l'effet naturel du résultat final. - Es wird empfohlen mit einer Fuge von 2/3 mm zu arbeiten, um am Ende den Verlegvorgang zu vereinfachen und die bestmögliche Natürlichkeit der Arbeit zu erzielen. - Для облегчения операций укладки и повышения натуральности вида конечного результата рекомендуется выполнять шов шириной 2-3 мм.

Al fine di facilitare la manutenzione ordinaria si raccomanda di effettuare un lavaggio acido dopo 48 ore dalla stuccatura con un acido specifico per grès porcellanato. - In order to favour the ordinary maintenance procedures, it is recommended to carry out an acid wash of the surface after 48 hours from grout filling using an acid agent specific for porcelain stoneware tiles. - Afin de faciliter l'entretien ordinaire de votre carrelage, nous vous conseillons de le laver 48 heures après le colmatage des joints, avec un acide spécifique pour grès cérame. - Um die Instandhaltung zu erleichtern, empfiehlt es sich 48 Stunden nach der Stuckatur mit einer sauren Lösung speziell für Feinsteinzeug zu waschen. - Чтобы упростить уход за плиткой, спустя 48 часов после затирки швов рекомендуется выполнить обработку кислотным продуктом, пригодным для керамогранита.

| | CARATTERISTICA TECNICA TECHNICAL CHARACTERISTIC CARACTERISTIQUE TECHNIC TECHNISCHE DATEN ТЕХНИЧЕСКАЯ ХАРАКТЕРИСТИКА | METODO DI PROVA TESTS METHOD METHODE D'ESSAI TESTMETHODE МЕТОД ИСПЫТАНИЯ | VALORE * MEDIO "CAESAR" AVERAGE "CAESAR" VALUE * VALEUR * MOYEN "CAESAR" "CAESAR" DURCHSCHNITTSWERT * СРЕДНЕЕ ЗНАЧЕНИЕ "CAESAR" * | |
|--|-------------------------------------------------------------------------------------------------------------------------------------------------------------------------------------------------------------------------------------|--------------------------------------------------------------------------------------|------------------------------------------------------------------------------------------------------------------------------------------------------------------------------|----------------------------------------------------------------------|
| | | | Lucidato | Matt |
| | Dimensione - Size Dimension - Abmessungen - Размер | ISO 10545-2 | Conforme - In accordance Conforme - Erfüllt - Соответствует | Conforme - In accordance Conforme - Erfüllt - Соответствует |
| | Assorbimento d'acqua* - Water absorption* Absorption d'eau* - Wasseraufnahme* - % Поглощения воды* | ISO 10545-3 | ≤ 0,1% | ≤ 0,1% |
| | Resistenza alla flessione* - Bending strength* Résistance à la flexion* - Biegezugfestigkeit* - Упругость* | ISO 10545-4 | Conforme - In accordance Conforme - Erfüllt - Соответствует | Conforme - In accordance Conforme - Erfüllt - Соответствует |
| | Resistenza all'urto - Impact resistance Résistance au choc - Schlagfestigkeit - Ударопрочность | ISO 10545-5 | ≥ 0,80 | ≥ 0,80 |
| | Resistenza all'abrasione profonda* - Deep scratch resistance* Résistance à l'abrasion profonde* - Widerstand gegen Tiefenverschleiß* Устойчивость к глубокому истиранию* | ISO 10545-6 | - | Conforme - In accordance Conforme - Erfüllt - Соответствует |
| | Coefficiente di dilatazione termica lineare* - Thermal linear expansion coefficient* Coefficient de dilatation thermique linéaire* - Koeffizient der linearen thermischen Dehnung* - Коэффициент линейного теплового расширения* | ISO 10545-8 | ≈ 7 (10° °C) | ≈ 7 (10° °C) |
| | Resistenza agli sbalzi termici* - Thermal shock resistance* Résistance aux écarts de température* - Temperaturwechsel Beständigkeit* Устойчивость к тепловому перепаду* | ISO 10545-9 | Conforme - In accordance Conforme - Erfüllt - Соответствует | Conforme - In accordance Conforme - Erfüllt - Соответствует |
| | Dilatazione all'umidità* - Expansion in humidity* Dilatation à l'humidité* - Feuchtigkeitsausdehnung* Расширение в условиях влажности* | ISO 10545-10 | Conforme - In accordance Conforme - Erfüllt - Соответствует | Conforme - In accordance Conforme - Erfüllt - Соответствует |
| | Resistenza al cavillo - Crazing resistance Résistance aux craquelures - Haariß-Beständigkeit Устойчивость эмали к краquelору | ISO 10545-11 | Conforme - In accordance Conforme - Erfüllt - Соответствует | - |
| | Resistenza al gelo* - Frost resistance* Résistance au gel* - Frostbeständigkeit* - Морозостойчивость* | ISO 10545-12 | Resistente - Resistant Résistante - Beständig - Стойкий | Resistente - Resistant Résistante - Beständig - Стойкий |
| | Resistenza all'attacco chimico* - Resistance to chemical attack* Résistance à l'attaque chimique* - Beständigkeit gegen Chemikalien* Устойчивость к химическому воздействию* | ISO 10545-13 | Resistente - Resistant Résistante - Beständig - Стойкий | Resistente - Resistant Résistante - Beständig - Стойкий |
| | Resistenza alle macchie* - Resistance to stains* Résistance aux taches* - Fleckenbeständigkeit* Устойчивость к образованию пятен* | ISO 10545-14 | Pulibile - Cleanable Nettoyable - Leicht zu reinigen - Чистящийся | Pulibile - Cleanable Nettoyable - Leicht zu reinigen - Чистящийся |
| | Resistenza allo scivolamento** - Slip resistance** Résistance au glissement** - Rutschhemmende Eigenschaft** Сопротивление скольжению** | DIN 51130 - DIN 51097 ▲ ANSI A326.3 | - - | R9 Matt Wet DCOF ≥ 0,42 |
| | Resistenza all'abrasione superficiale - Surface abrasion resistance Résistance à l'abrasion superficielle - Widerstand gegen Oberflächenverschleiß Сопротивление на изгиб и усилию на излом | EN ISO 10545-7 | Test disponibili in azienda Tests available at our company Tests disponibles en usine Prüfzeugnisse beim Werk erhältlich Протоколы испытаний хранятся в компании | - |
| | Durezza Mohs - Mohs hardness Dureté Mohs - Ritzhärte nach Mohs - Устойчивость к изгибу | EN 101 | Coeff. 5 | Coeff. 6 |
| | Spessore nominale - Nominal Thickness Épaisseur nominale - Nominalstärke Номинальная толщина | | 6 mm 120x278 9 mm 120x120 - 60x120 - 80x80 - 60x60 - 30x60 | 9 mm |

* Valori medi riferiti agli ultimi due anni di produzione e relativi alla finitura naturale del prodotto - Average values referred to the last two years of production and related to the matt finish of the product - Valeurs moyennes des deux dernières années de production et relatifs à la finition naturelle du produit - Durchschnittswerte, die sich auf die letzten zwei Produktionsjahre beziehen und auf die matte Oberfläche - Средние значения относятся к последним двум годам производства и натуральной отделке поверхности

** Valori relativi alla finitura naturale del prodotto ed a test effettuati da laboratori esterni accreditati, disponibili in azienda; ci rendiamo disponibili alla verifica dell'eventuale lotto interessato all'acquisto. - As far as values relating to the matt finish of the product and to tests carried out by certified external laboratories whose results are available upon request at Headoffice, we are willing to check the lot you are interested in purchasing. - Valeurs se référant à la finition naturelle du produit selon des tests effectués par des laboratoires extérieurs accrédités et à la disposition de toute personne intéressée auprès de nos bureaux; nous sommes disponibles pour le contrôle de l'éventuel lot concerné par l'achat. - Werte bezogen auf das natürliche Produktfinish und in anerkannten externen Labors geprüft, im Unternehmen erhältlich; für eventuelle Prüfungen der zu erwerbenden Warenposten stehen wir gern zur Verfügung. - Значения, касающиеся натуральных характеристик изделий и тестов, выполненных внешними авторизованными лабораториями, имеются в компании. Мы готовы выполнить проверку партии товара, которую намереваемся приобрести.

• Per prodotti chimici di uso domestico e additivi per piscina. - For domestic chemicals and swimming pool additives. - Pour produits chimiques à usage domestique et additifs pour piscines. - Für chemische Produkte für den Hausgebrauch und Schwimmbadzusätze. - Для бытовых химикатов и добавок для бассейнов.

▲ Valori wet DCOF specifici disponibili in azienda - Wet DCOF specific values available at the company - Valeurs wet DCOF spécifiques disponibles à l'usine - Prüfwerte Wet DCOF stehen im Werk zur Verfügung - Показатели wet DCOF доступны при запросе

Le tonalità dei campioni sono da considerarsi puramente indicative. - Tones of samples are indicative. - Les tonalités des échantillons sont purement indicatives. Die farbtoñer der Muster sind als rein indicativ zu betrachten. - Тона образцов ориентировочные.

Wood Look

Le infinite sfumature di una materia dall'elegante respiro, dalle varianti naturali a quelle vissute e trattate, per offrirti l'opportunità di sposare comfort e prestazioni.

The infinite differences in shade of a material with an elegant appeal, featuring natural variations or treated and vintage versions, offering you the opportunity to combine comfort with performance.

Les nuances infinies d'un matériau élégant, des variantes naturelles à celles patinées et traitées, pour vous offrir l'opportunité d'associer confort et performances.

Unendliche Nuancen eines Materials von ganz eigener Eleganz. Von naturbelassener Optik bis zu Vintage-Varianten und besonderen Behandlungen. Komfort und Leistung in einem.

Материал с элегантным характером и множеством оттенков, от естественных до отмеченных временем, объединяющий комфорт и высокую технологичность.



Wood Look

The collections

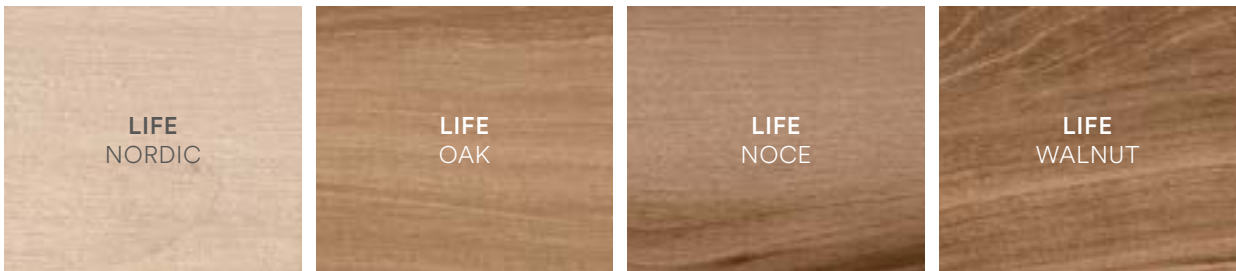
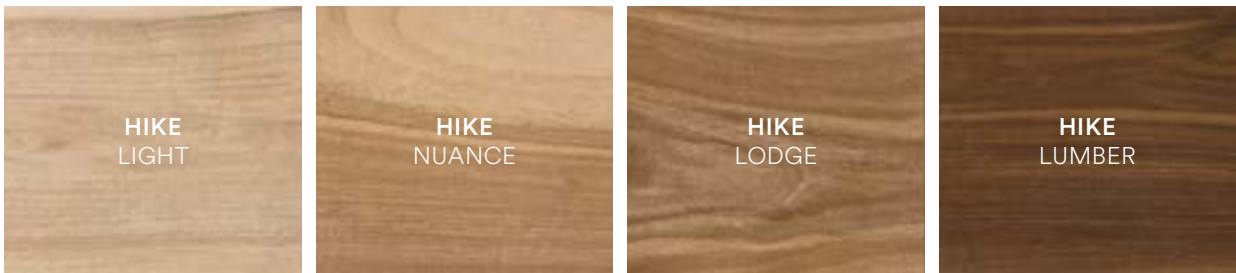
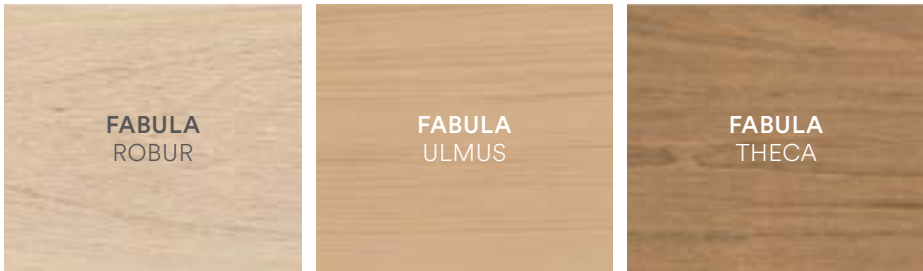
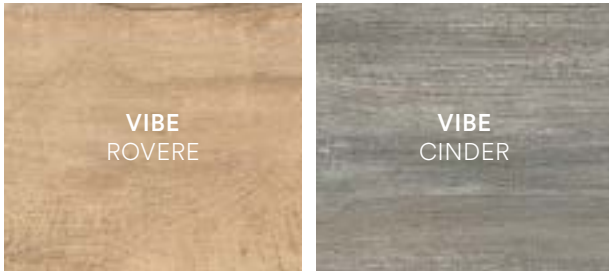
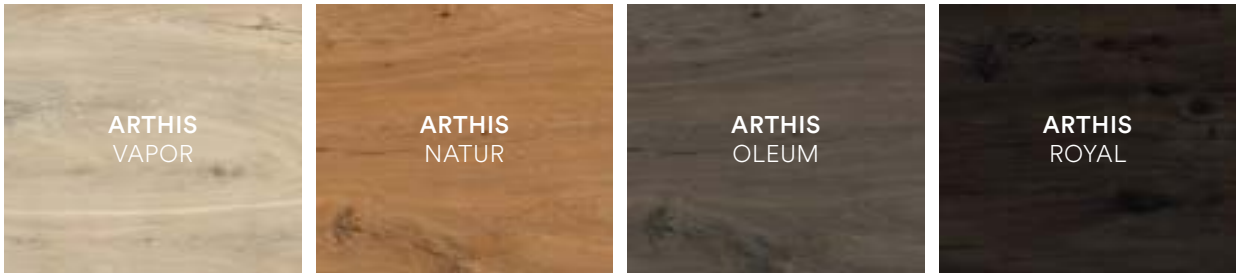

Arthis

Woods and crafts



Dalle nobili arti che hanno elevato a maestria la lavorazione del legno, l'ispirazione per una collezione in grès porcellanato di straordinaria bellezza. Arthis infonde nuova linfa alla capacità di tramutare la materia naturale in sapienza artigianale, portando in dote calore ed eleganza in qualsiasi contesto di design.

The noble arts that transformed woodworking into a master's craft are the inspiration for an extraordinarily beautiful collection of porcelain stoneware. Arthis nourishes with new life the capacity to turn a natural material into the skill of the artisan, to bring warmth and elegance to any design context.

La maestria artisanale qui a élevé le travail du bois au rang d'un art véritable inspire cette collection de grès cérame d'une extraordinaire beauté. Arthis imprime un nouvel élan à la capacité de transformer la matière naturelle en savoir-faire artisanal et apporte chaleur et élégance dans n'importe quel environnement design.

Von den noblen Künsten, die die Holzbearbeitung zur Meisterschaft erhoben haben, stammt die Inspiration für eine Feinsteinzeugkollektion von außergewöhnlicher Schönheit. Arthis verleiht der Kunst, die natürliche Materie in handwerkliche Meisterwerke zu verwandeln, neuen Schwung. Und bringt damit Wärme und Eleganz in jeden Designkontext.

Вдохновением для создания керамогранитной коллекции удивительной красоты послужило прикладное искусство, которое возвело обработку дерева в ранг мастерства. Arthis оживляет навыки превращения натурального материала в ремесленное умение, принося тепло и элегантность в любое дизайнерское пространство.



Info
Resources
Tools



Colori - Formati

Colors - Sizes

20x120 9 mm MATT RT
 20x120 CHEVRON 9 mm MATT RET
 30x120 20 mm AEXTRA20 RT R11 C

VAPOR



NATUR



OLEUM



ROYAL

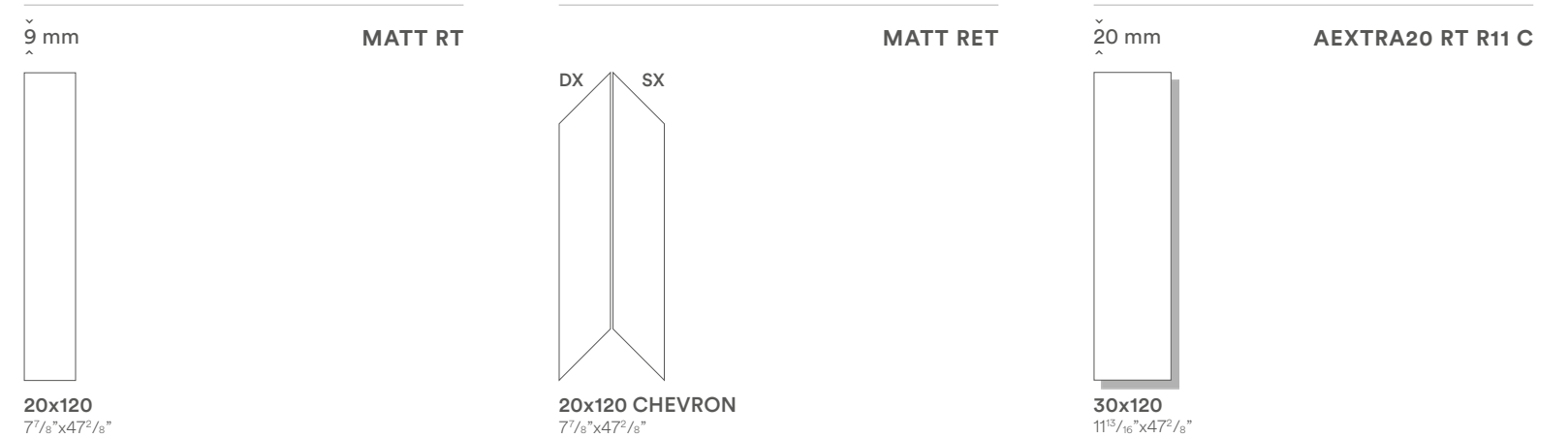

La gamma

The range

| | VAPOR | NATUR | OLEUM | ROYAL |
|----------------------|---------------------------|---------------------------|---------------------------|---------------------------|
| MATT RT MATT RET* | 20x120 20x120 Chevron* | 20x120 20x120 Chevron* | 20x120 20x120 Chevron* | 20x120 20x120 Chevron* |
| AEXTRA20 RT R11 C | 30x120 | 30x120 | | |

*La liste a jour des produits et formats des series certifiees QB-UPEC est disponible en usine.

RT Rettificato, quadrato, monocalibro. - Rectified, squared, one caliber. - Rectifié, mis d'équerre et monocalibre. - Rektifiziert, rechtwinkelig und Ein kaliber. - Ректифицированный, одного калибра.
 RET Rettificato. - Rectified. - Rectifié. - Rektifiziert. - Ректифицированный.

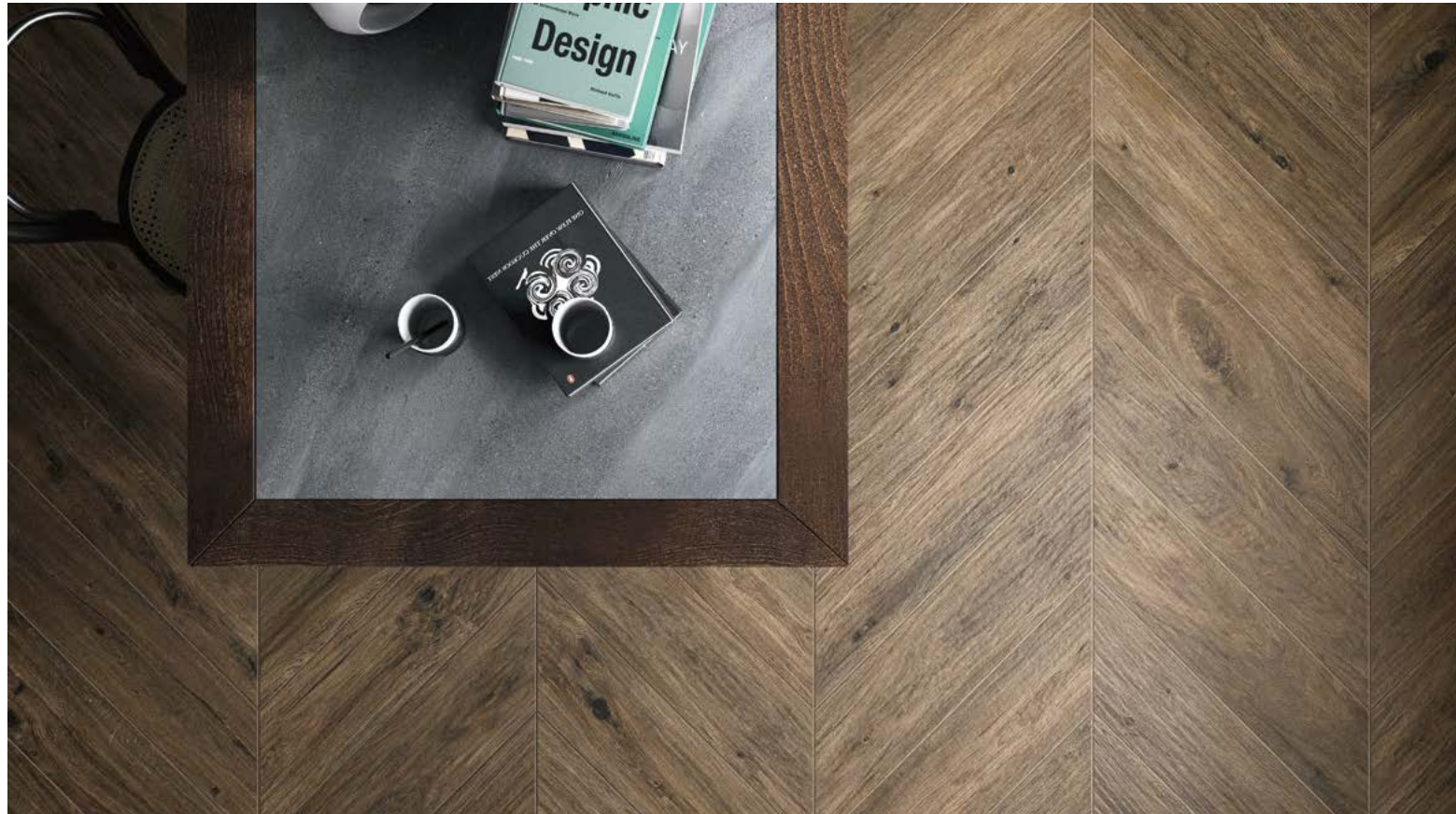

| | A E X T R A 2 0 | | |
|-------|---------------------------------------------------------------------------------------------------------|------------------------------------------------------------------------------------------------------------------|------------------------------------------------------------------------------------------------------------|
| | | | |
| | 20x120 cm 7 ¹ / ₈ "x47 ² / ₈ " 9 mm MATT RT | 20x120 cm Chevron 7 ¹ / ₈ "x47 ² / ₈ " 9 mm MATT RET | 30x120 cm 11 ³ / ₈ "x47 ² / ₈ " 20 mm RT R11 C |
| | | | |
| | | | 6,2x60 cm 2 ¹ / ₈ "x23 ⁵ / ₈ " MATT |
| | | | |
| | | | Battiscopa - Bullnose Plinthe - Sockel Плинтус |
| Vapor | ● | ● | ● |
| Natur | ● | ● | ● |
| Oleum | ● | ● | ● |
| Royal | ● | ● | ● |

IMBALLI - PACKAGING - CONDITIONNEMENT - VERPACKUNGS-EINHEITEN - УПАКОВКА

| Formato - Size - Format - Формат | Scatola - Box - Boîte - Karton - Коробка | Pallet - Palette - Палета | | | | | |
|----------------------------------|-------------------------------------------------------------------|---------------------------|------|--------|----|-------|----------|
| CM | PZ | MQ | KG | SC | MQ | KG | |
| 20x120 | 7 ¹ / ₈ "x47 ² / ₈ " | 6 | 1,44 | ~31,10 | 32 | 46,08 | ~995,20 |
| 20x120 Chevron | 7 ¹ / ₈ "x47 ² / ₈ " | 4 | 0,80 | ~17,20 | 40 | 32,00 | ~688,00 |
| 30x120 A E X T R A 2 0 | 11 ³ / ₈ "x47 ² / ₈ " | 2 | 0,72 | ~33,35 | 36 | 25,92 | ~1200,60 |

20x120 Chevron è incastolato a 4 pezzi per scatola, suddivisi tra 2 destri e 2 sinistri. - 20x120 Chevron is packed in boxes containing 4 pieces each, 2 left and 2 right. - Les carreaux 20x120 Chevron sont conditionnés 4 par 4, 2 droits et 2 gauches. - 20x120 Chevron ist in Kartons mit jeweils 4 Fliesen, 2 rechten und 2 linken, verpackt. - 20x120 Chevron упаковывается по 4 штуки на коробку, 2 правые и 2 левые.

RT Rettificato, squadrato, monocalibro. - Rectified, squared, one caliber. - Rectifié, mis d'équerre et monocalibre. - Ректифициert, rechtwinkelig und Ein kaliber. - Ректифицированный, одного калибра.
RET Rettificato. - Rectified. - Rectifié. - Ректифициert. - Ректифицированный.

Si raccomanda l'utilizzo di una fuga di 2/3 mm al fine di semplificare le operazioni di posa e ottimizzare la naturalezza del risultato finale. - We recommend you a 2/3 mm grout joint to simplify the laying and optimize the naturalness of the final result. - Un joint de 2/3 mm est conseillé afin de simplifier les opérations de pose et optimiser l'effet naturel du résultat final. - Es wird empfohlen mit einer Fuge von 2/3 mm zu arbeiten, um am Ende den Verlegvorgang zu vereinfachen und die bestmögliche Natürlichkeit der Arbeit zu erzielen. - Для облегчения операций укладки и повышения натуральности вида конечного результата рекомендуется выполнять шов шириной 2-3 мм.

Al fine di facilitare la manutenzione ordinaria si raccomanda di effettuare un lavaggio acido dopo 48 ore dalla stuccatura con un acido specifico per grès porcellanato. - In order to favour the ordinary maintenance procedures, it is recommended to carry out an acid wash of the surface after 48 hours from grout filling using an acid agent specific for porcelain stoneware tiles. - Afin de faciliter l'entretien ordinaire de votre carrelage, nous vous conseillons de le laver 48 heures après le colmatage des joints, avec un acide spécifique pour grès cérame. - Um die Instandhaltung zu erleichtern, empfiehlt es sich 48 Stunden nach der Stuckatur mit einer sauren Lösung speziell für Feinsteinzeug zu waschen. - Чтобы упростить уход за плиткой, спустя 48 часов после затирки швов рекомендуется выполнить обработку кислотным продуктом, пригодным для керамогранита.

CARATTERISTICHE TECNICHE

TILE PERFORMANCE DATA - NOTES TECHNIQUES - TECHNISCHE AUSKÜNFTE - ТЕХНИЧЕСКАЯ ХАРАКТЕРИСТИКА

Classificazione secondo EN ISO 14411 ISO 13006 annesso G gruppo Bla con Ev ≤0,5% - Classification in accordance with EN ISO 14411 ISO 13006 annex G standards Bla with Ev ≤ 0,5% - Classification selon EN ISO 14411 ISO 13006 annexe G groupe Bla avec Ev ≤0,5% - Klassifizierung gemäß EN ISO 14411 ISO 13006 anlage G Gruppe Bla mit Ev ≤0,5% - Классификация в соответствии с EN ISO 14411 ISO 13006, приложение G, стандарт Bla, где Ev ≤0,5%

| | CARATTERISTICA TECNICA TECHNICAL CHARACTERISTIC CARACTERISTIQUE TECHNIQUE TECHNISCHE DATEN ТЕХНИЧЕСКАЯ ХАРАКТЕРИСТИКА | METODO DI PROVA TESTS METHOD METHODE D'ESSAI TESTMETHODE МЕТОД ИСПЫТАНИЯ | VALORE * MEDIO "CAESAR" AVERAGE "CAESAR" VALUE* VALEUR * MOYEN "CAESAR" "CAESAR" DURCHSCHNITTSWERT* СРЕДНЕЕ ЗНАЧЕНИЕ "CAESAR"* | VALORE * MEDIO "CAESAR" AVERAGE "CAESAR" VALUE A E X T R A 2 0 OPEN YOUR STYLE |
|--|--------------------------------------------------------------------------------------------------------------------------------------------------------------------------------------------------------------------------------------------|--------------------------------------------------------------------------------------|--------------------------------------------------------------------------------------------------------------------------------------------|---------------------------------------------------------------------------------------------------------------------------------------------------------------------------------------------------------------------------------------------------------------------------------------------------------------------------------------------|
| | Dimensione - Size Dimension - Abmessungen - Размер | ISO 10545-2 | Conforme - In accordance Conforme - Erfüllt - Соответствует | Conforme - In accordance Conforme - Erfüllt - Соответствует |
| | Assorbimento d'acqua* - Water absorption* Absorption d'eau* - Wasseraufnahme* - % Поглощения воды* | ISO 10545-3 | ≤ 0,1% | ≤ 0,1% |
| | Resistenza alla flessione* - Bending strength* Résistance à la flexion* - Biegezugfestigkeit* - Упругость* | ISO 10545-4 | Conforme - In accordance Conforme - Erfüllt - Соответствует | Non applicabile a piastrelle con una forza di rottura ≥ 3000 N Not applicable to tiles with a breaking strength ≥ 3000 N N'est pas applicable aux carreaux avec une charge de rupture ≥ 3000 N Nicht anwendbar bei Fliesen mit einer Bruchlast ≥ 3000 N Не применяется в отношении плиток с прочностью на изрыв ≥ 3000 N |
| | Sforzo di rottura (S) - Breaking strength Charge de rupture - Bruchlast - Разрушающее усилие | ISO 10545-4 | Sps ≥ 7,5 mm S ≥ 1300 N | > 10.000 N |
| | Resistenza all'abrasione profonda* - Deep scratch resistance* Résistance à l'abrasion profonde* - Widerstand gegen Tiefenverschleiß* Устойчивость глубокому истиранию* | ISO 10545-6 | Conforme - In accordance Conforme - Erfüllt - Соответствует | Conforme - In accordance Conforme - Erfüllt - Соответствует |
| | Coefficiente di dilatazione termica lineare* - Thermal linear expansion coefficient* Coefficient de dilatation thermique linéaire* - Koeffizient der linearen thermischen Dehnung* - Коэффициент линейного теплового расширения* | ISO 10545-8 | = 7 (10 ⁻⁶ °C ⁻¹) | = 7 (10 ⁻⁶ °C ⁻¹) |
| | Resistenza agli sbalzi termici* - Thermal shock resistance* Résistance aux écarts de température* - Temperaturwechsel Beständigkeit* Устойчивость к тепловому перепаду* | ISO 10545-9 | Resistente - Resistant Résistante - Beständig - Стойкий | Resistente - Resistant Résistante - Beständig - Стойкий |
| | Dilatazione all'umidità* - Expansion in humidity* Dilatation à l'humidité* - Feuchtigkeitsausdehnung* Расширение в условиях влажности* | ISO 10545-10 | ≤ 0,1 (mm/m) | ≤ 0,1 (mm/m) |
| | Resistenza al gelo* - Frost resistance* Résistance au gel* - Frostbeständigkeit* - Морозостойчивость* | ISO 10545-12 | Resistente - Resistant Résistante - Beständig - Стойкий | Resistente - Resistant Résistante - Beständig - Стойкий |
| | Resistenza all'attacco chimico* - Resistance to chemical attack* Résistance à l'attaque chimique* - Beständigkeit gegen Chemikalien* Устойчивость к химическому воздействию* | ISO 10545-13 | Resistente - Resistant Résistante - Beständig - Стойкий | Resistente - Resistant Résistante - Beständig - Стойкий |
| | Carico statico - Static load Charge statique - Statische Last Статическая нагрузка | EN 12825 | - | 30x120 KN>3,0 |
| | Resistenza alle macchie* - Resistance to stains* Résistance aux taches* - Fleckenbeständigkeit* Устойчивость к образованию пятен* | ISO 10545-14 | Pulibile - Cleanable Nettoyable - Leicht zu reinigen Чистящийся | Centro - Centre - Au centre - Mitte - По центру Centro lato - Side centre - Au centre latéralement Mitte Seite - По центру грани Diagonale - Diagonal - En diagonale Diagonal - По диагонали KN>3,0 KN>6,5 |
| | Resistenza allo scivolamento** - Slip resistance** Résistance au glissement** - Rutschhemmende Eigenschaft** Сопротивление скольжению** | DIN 51130 - DIN 51097 ▲ ANSI A326.3 | R9 Matt Wet DCOF ≥ 0,42 | Pulibile - Cleanable Nettoyable - Leicht zu reinigen Чистящийся R11 C Wet DCOF ≥ 0,55 |
| | Spessore nominale - Nominal Thickness Épaisseur nominale - Nominalstärke Номинальная толщина | | 9 mm | 20 mm |

* Valori medi riferiti agli ultimi due anni di produzione e relativi alla finitura naturale del prodotto - Average values referred to the last two years of production and related to the matt finish of the product - Valeurs moyennes des deux dernières années de production et relatifs à la finition naturelle du produit - Durchschnittswerte, die sich auf die letzten zwei Produktionsjahre beziehen und auf die matte Oberfläche - Средние значения относятся к последним двум годам производства и натуральной отделке поверхности

** Valori relativi alla finitura naturale del prodotto ed a test effettuati da laboratori esterni accreditati, disponibili in azienda; ci rendiamo disponibili alla verifica dell'eventuale lotto interessato all'acquisto. - As far as values relating to the matt finish of the product and to tests carried out by certified external laboratories whose results are available upon request at Headoffice, we are willing to check the lot you are interested in purchasing. - Valeurs se référant à la finition naturelle du produit selon des tests effectués par des laboratoires extérieurs accrédités et à la disposition de toute personne intéressée auprès de nos bureaux; nous sommes disponibles pour le contrôle de l'éventuel lot concerné par l'achat. - Werte bezogen auf das natürliche Produktfinish und in anerkannten externen Labors geprüft, im Unternehmen erhältlich; für eventuelle Prüfungen der zu erwerbenden Warenposten stehen wir gern zur Verfügung. - Значения, касающиеся натуральных характеристик изделий и тестов, выполненных внешними авторизованными лабораториями, имеются в компании. Мы готовы выполнить проверку партии товара, которую намереваетесь приобрести.

• Per prodotti chimici di uso domestico e additivi per piscina. - For domestic chemicals and swimming pool additives. - Pour produits chimiques à usage domestique et additifs pour piscines. - Für chemische Produkte für den Hausgebrauch und Schwimmbadzusätze. - Для бытовых химикатов и добавок для бассейнов.

▲ Valori wet DCOF specifici disponibili in azienda - Wet DCOF specific values available at the company - Valeurs wet DCOF spécifiques disponibles à l'usine - Prüfwerte Wet DCOF stehen im Werk zur Verfügung - Показатели wet DCOF доступны при запросе

Le tonalità dei campioni sono da considerarsi puramente indicative. - Tones of samples are indicative. - Les tonalités des échantillons sont purement indicatives. Die farbtöne der Muster sind als rein indicativ zu betrachten. - Тона образцов ориентировочные.

Cocoon

Warm emotions



Il look di una delle essenze più pregiate, per vestire la casa e gli altri spazi architettonici di atmosfere calde e avvolgenti. Luoghi in cui assaporare momenti di vita quotidiana intensi e appaganti, abbracciati da un design naturale ed elegante, semplice e attuale. Cocoon è la combinazione ideale per dare voce, respiro e massimo valore alle emozioni.

The look of one of the most precious types, to dress the home and other architectural spaces with warm and enveloping atmospheres. Places to enjoy intense and fulfilling moments of everyday life, embraced by a natural and elegant, simple and contemporary design. Cocoon is the ideal combination to fully express your emotions.

L'aspect d'une des essences les plus prisées, pour créer dans la maison et les autres espaces architecturaux des ambiances chaleureuses et accueillantes. Des lieux dans lesquels goûter des moments de vie quotidienne intenses et enrichissants, enveloppés dans un design naturel et élégant, simple et actuel. Cocoon est la combinaison idéale pour exprimer les émotions, leur donner du souffle et toute la valeur qu'elles méritent.

Die Optik eines der edelsten Hölzer kleidet die Wohnung und andere Orte in eine warme und behagliche Atmosphäre. Orte, an denen wir schöne Momente genießen, umgeben von einem natürlich-eleganten, schlichten und stets aktuellen Design. Cocoon ist die ideale Kombination, mit der wir unsere Empfindungen optimal ausdrücken und zur Geltung bringen können.

Один из самых ценных и чарующих материалов украшает дома и другие архитектурные пространства, создавая теплую и уютную атмосферу. Получаются места с естественным и элегантным, простым и современным дизайном, где можно насладиться насыщенными и приятными моментами повседневной жизни. Cocoon – это идеальная комбинация, которая дарит эмоциям голос, дыхание и максимальную ценность. при наличии высокой интенсивности хождения и движения.



Info
Resources
Tools



Colori - Formati

Colors - Sizes

20x120 9 mm MATT RT
 20x120 CHEVRON . 20x120 ARCH 9 mm MATT RET
 7,5x45 CHEVRON 9 mm MATT NR
 20x120 9 mm GRIP RT R11 C
 30x120 . 60x60 20 mm AEXTRA20 RT R11 C

BLISS



GLEE



JOY



PEACE





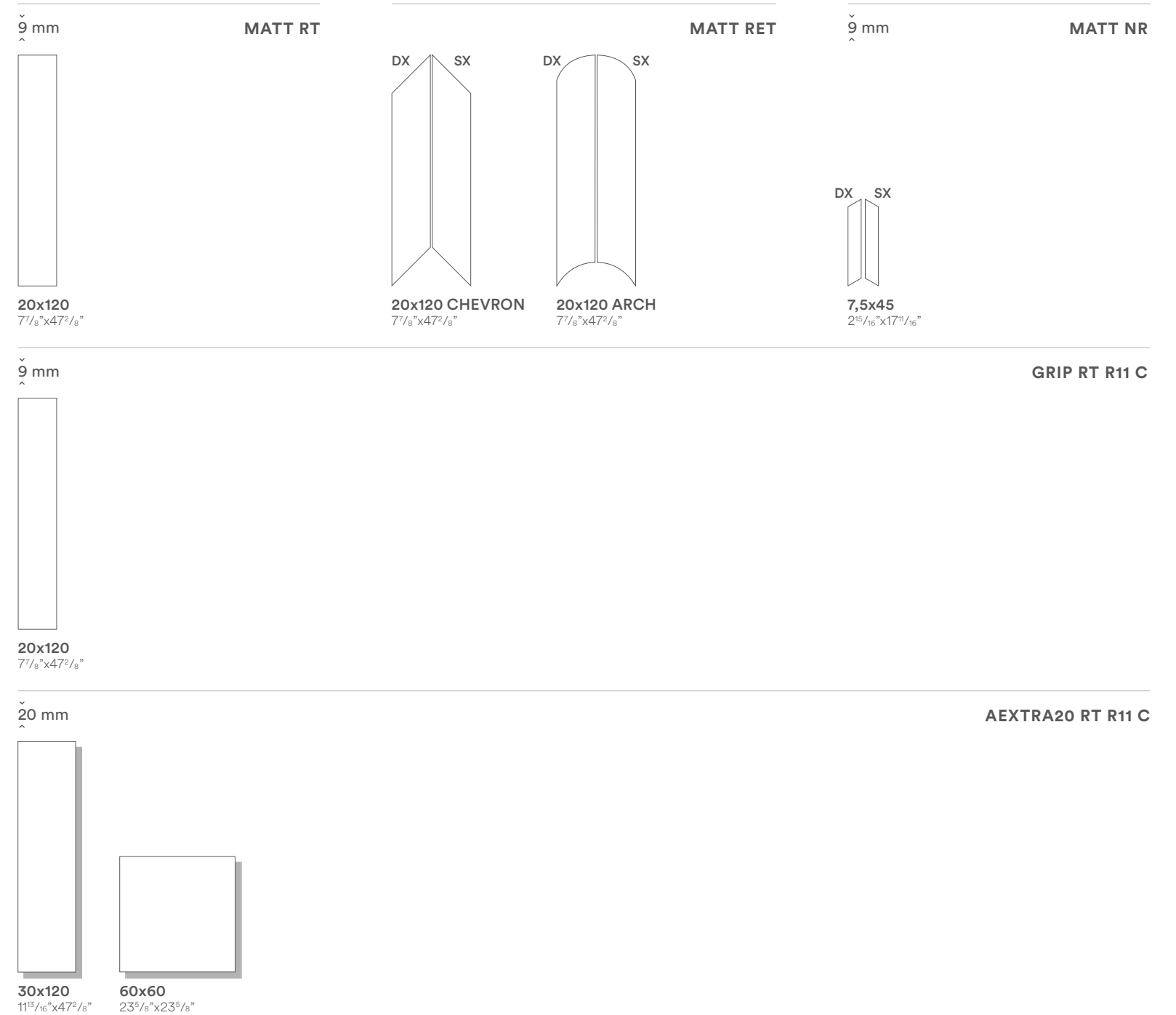









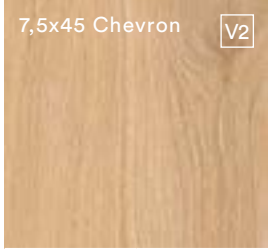
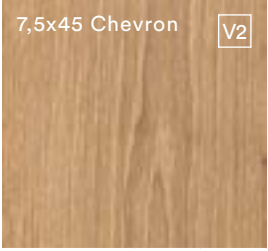
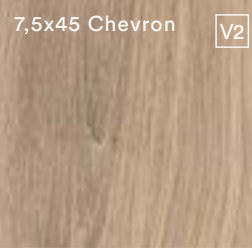
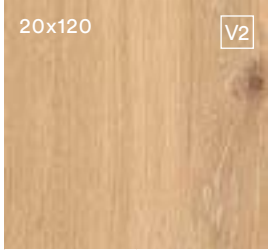
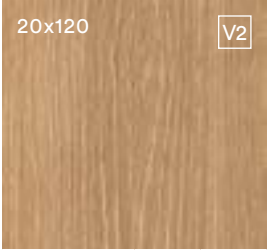
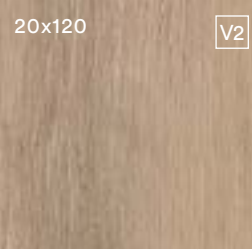

EASE



La gamma

The range

| | BLISS | GLEE | JOY | PEACE  | EASE |
|------------------------------------|---------------------------------------------------------------------------------------|-------------------------------------------------------------------------------------------------------------------------------------------------------------------------------|---------------------------------------------------------------------------------------|--------------------------------------------------------------------------------------------------------------------------------------------------------------------------------|-----------------------------------------------------------------------------------------|
| MATT RT MATT RET* |  V2 |  V2 |  V2 |  V2 |  V2 |
| MATT NR | |  V2 |  V2 | |  V2 |
| GRIP RT R11 C |  V2 |  V2 | | |  V2 |
| AEXTRA20 RT R11 C | |  V2  | |  V2  | |
| | |  V2  | |  V2  | |

* Doga - Plank size - Lame - Diele - Доска

°° Listellato - Listel size - Multifrise - Leistenoptik - Эффект соединенных планок

Nei formati 80x80 e 60x60 l'estetica dei prodotti richiama doghe accostate tra loro o un look a cassettoni, mentre nel formato 30x120 viene riprodotta soltanto la texture del legno. - In the 80x80 and 60x60 sizes, the styling of the products recalls planks placed side-by-side or a coffered look, while the 30x120 size reproduces the texture of wood alone. - Dans les formats 80x80 et 60x60 l'esthétique des produits rappelle des listels ou un aspect à caissons alors que le format 30x120 reproduit uniquement la texture du bois. - In den Formaten 80x80 und 60x60 Verweist die Optik der Produkte auf Aneinandergelegte Dielen Oder auf Ein Kassettenmotiv, während im Format 30x120 nur die Struktur des Holzes wiedergegeben wird. - В форматах 80x80 и 60x60 эстетика плитки напоминает размещенные рядом доски или кесонный потолок, в то время как в формате 30x120 воспроизводится только текстура дерева.

RT Rettificato, squadrato, monocalibro. - Rectified, squared, one caliber. - Rectifié, mis d'équerre et monocallibre. - Rektifiziert, rechtwinkelig und Ein kaliber. - Ректифицированный, одного калибра.

RET Rettificato. - Rectified. - Rectifié. - Rektifiziert. - Ректифицированный.

NR Non rettificato. - Not rectified. - Non rectifié. Nicht rektifiziert. - Не ретицированный.

Decori

Decors

CADENCE 20x120 cm . 7⁷/₈"x47⁷/₈" MATT RT
Available in all colors



Decori

Decors

STAVE 30x120 cm . 11¹³/₁₆"x47²/₈" MATT



BLISS



GLEE



JOY



PEACE



EASE

STAVE 3D 20x120 cm . 7⁷/₈"x47²/₈" MATT



BLISS



GLEE



JOY



PEACE



EASE



CHEVRON 20x120 cm . 7⁷/₈"x47²/₈" MATT RET - BLISS, GLEE, JOY, PEACE, EASE

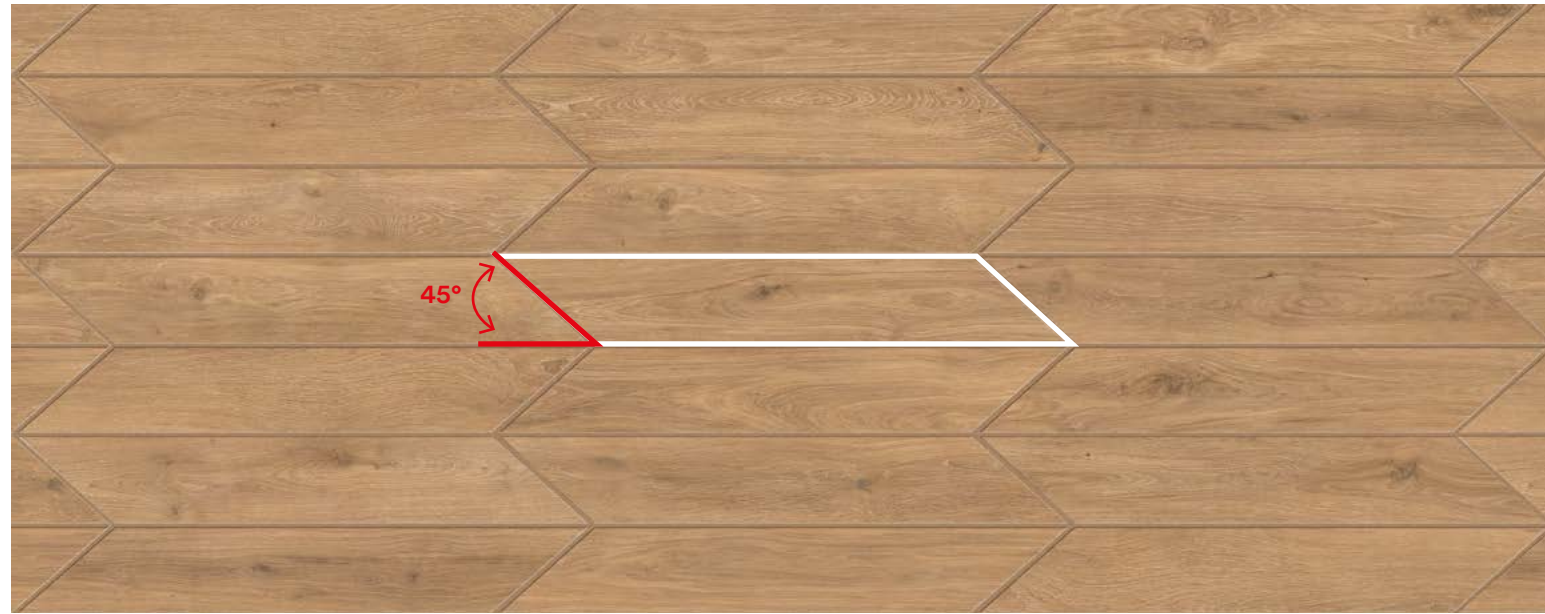

ARCH 20x120 cm . 7⁷/₈"x47²/₈" MATT RET - BLISS, GLEE, JOY, PEACE, EASE

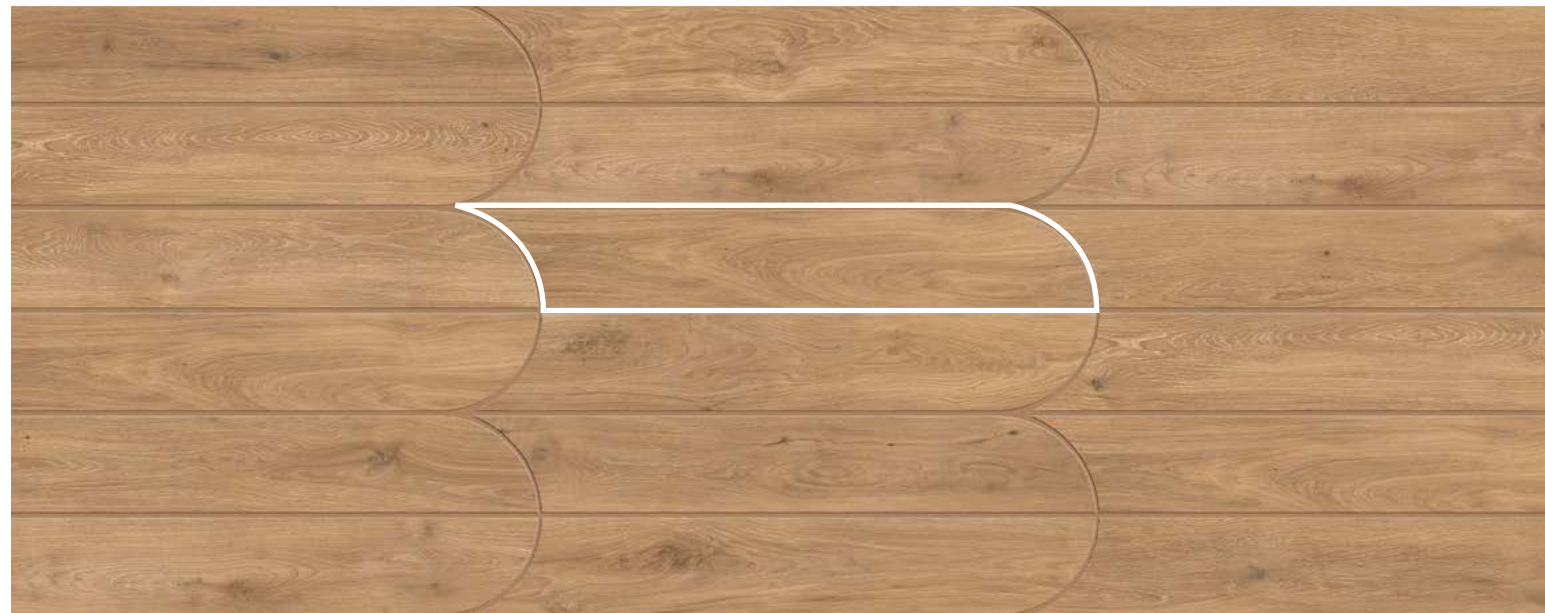

CHEVRON 7,5x45 cm . 2¹⁵/₁₆"x17¹¹/₁₆" MATT NR - GLEE, JOY, EASE

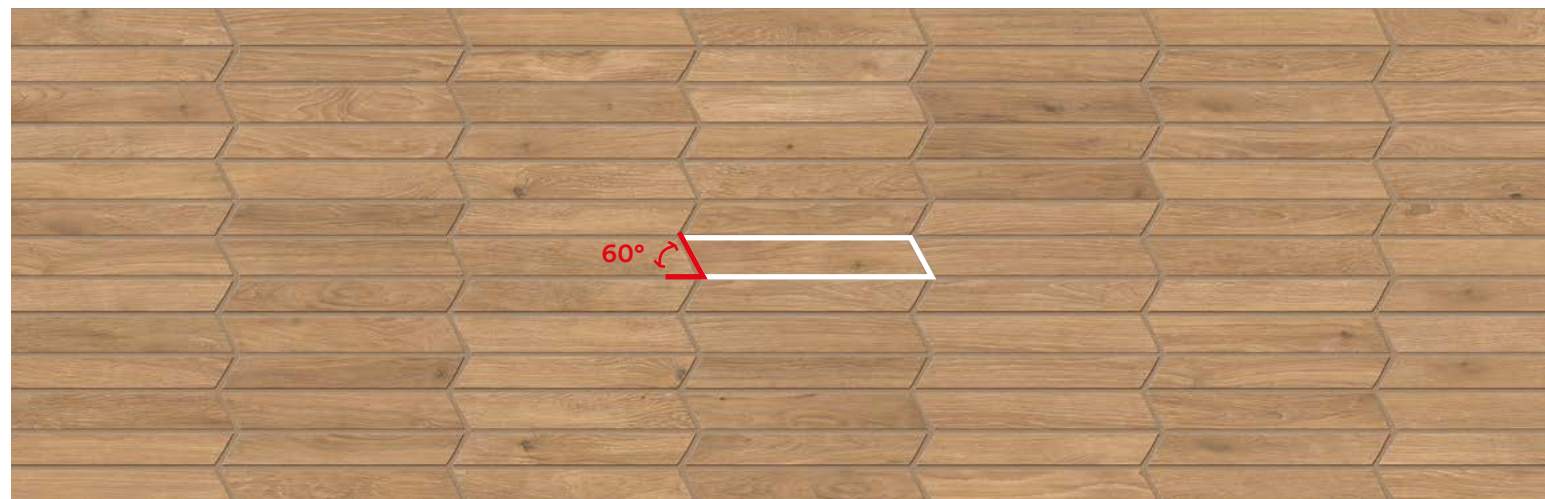

RET Rettificato. - Rectified. - Rectifié. - Rektifiziert. - Ректифицированный.
NR Non rettificato. - Not rectified. - Non rectifié. Nicht rektifiziert. - Не ретифицированный.

SUGGERIMENTI DI POSA ARCH INSTALLATION SUGGESTIONS FOR ARCH

Arch è una soluzione elegante e innovativa per pavimenti e rivestimenti: si presta a diverse tipologie di posa, come quelle illustrate di seguito.

Arch is an elegant and innovative solution for covering floors and walls: it may be installed in many different ways, such as those shown below.

Arch est une solution élégante et innovante pour sols et revêtements muraux qui convient à différents types de pose comme ceux illustrés ci-dessous.

Arch bietet sich für elegante und innovative Wand- und Bodenbeläge an und erlaubt verschiedene Verlegemuster, wie die im Folgenden dargestellten Beispiele zeigen.

Arch - это элегантное и инновационное решение для настенной и напольной плитки: она поддается различным видам укладки, например, таким, как показано ниже.



20x120 = 100%

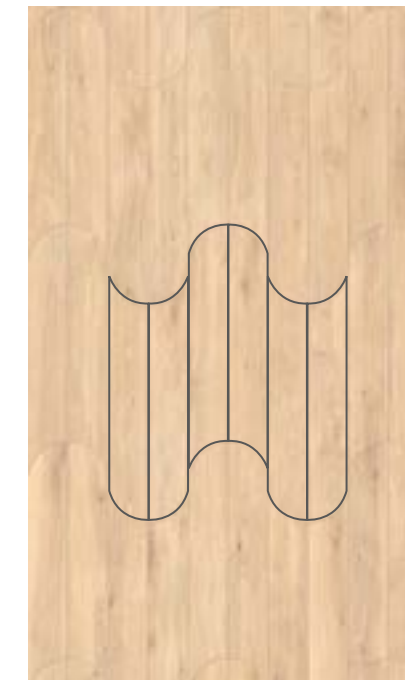

20x120 = 100%

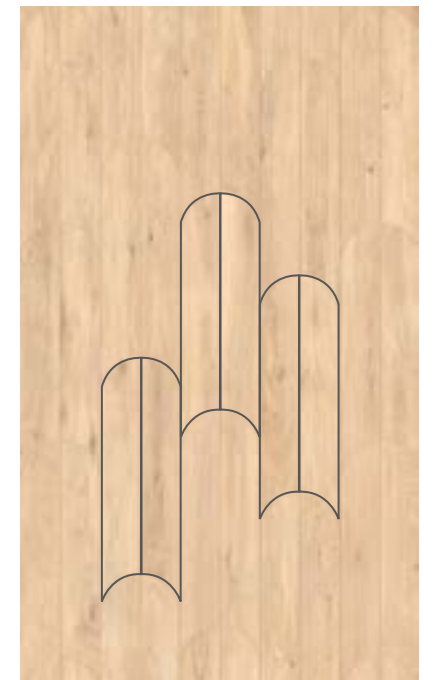

20x120 = 100%

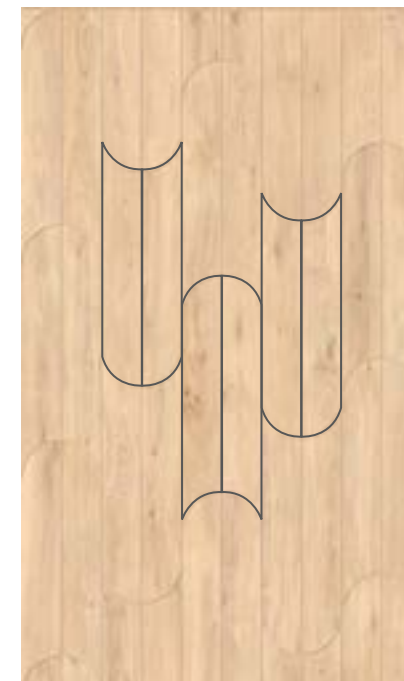

20x120 = 100%



20x120 = 100%

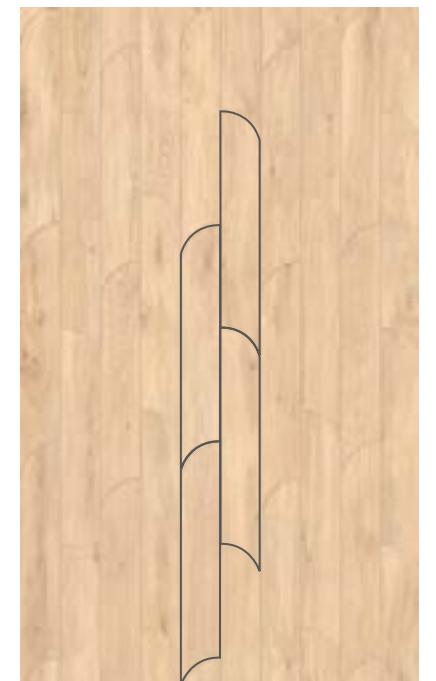

20x120 = 100%



| | 20x120 cm 7 1/8" x 4 7/8" / 9 mm | | 20x120 cm Chevron 7 1/8" x 4 7/8" / 9 mm | | 20x120 cm Arch 7 1/8" x 4 7/8" / 9 mm | | 7,5x45 cm Chevron 2 9/16" x 1 7 1/16" / 9 mm | | 30x120 cm ° 11 13/16" x 4 7/8" / 20 mm | | 60x60 cm °° 23 5/8" x 23 5/8" / 20 mm | | 6,2x60 cm 2 1/16" x 23 5/8" / 20 mm | |
|-------|-------------------------------------|---------------|---------------------------------------------|----------|------------------------------------------|----------|-------------------------------------------------|------|------------------------------------------------------|--|------------------------------------------|--|----------------------------------------|--|
| | MATT RT | GRIP RT R11 C | MATT RET | MATT RET | MATT NR | RT R11 C | RT R11 C | MATT | Battiscopa - Bullnose Plinthe - Sockel Плинтус | | | | | |
| Bliss | ● | | ● | ● | ● | | | ● | | | | | | |
| Glee | ● | ● | ● | ● | ● | | | ● | | | | | | |
| Joy | ● | ● | ● | ● | ● | | | ● | | | | | | |
| Peace | ● | | ● | ● | ● | | | ● | | | | | | |
| Ease | ● | ● | ● | ● | ● | | | ● | | | | | | |

IMBALLI - PACKAGING - CONDITIONNEMENT - VERPACKUNGS-EINHEITEN - УПАКОВКА

| Formato - Size - Format - Формат | | Scatola - Box - Boîte - Karton - Коробка | | | Pallet - Palette - Палета | | |
|----------------------------------|---------------------|------------------------------------------|--------|--------|---------------------------|-------|----------|
| CM | INCHES | PZ | MQ | KG | SC | MQ | KG |
| 20x120 | 7 1/8" x 4 7/8" | 6 | 1,44 | ~31,10 | 32 | 46,08 | ~995,20 |
| 20x120 Chevron | 7 1/8" x 4 7/8" | 4 | 0,80 | ~17,20 | 40 | 32,00 | ~688,00 |
| 20x120 Arch | 7 1/8" x 4 7/8" | 4 | 0,8216 | ~17,20 | - | - | - |
| 7,5x45 Chevron | 2 9/16" x 1 7 1/16" | 26 | 0,8775 | ~17,90 | 56 | 49,14 | ~1002,40 |
| 60x60 A E X T R A 2 0 | 23 5/8" x 23 5/8" | 2 | 0,72 | ~32,00 | 30 | 21,60 | ~960,00 |
| 30x120 A E X T R A 2 0 | 11 13/16" x 4 7/8" | 2 | 0,72 | ~33,35 | 36 | 25,92 | ~1200,60 |

20x120 Chevron e 20x120 Arch sono incastolati a 4 pezzi per scatola, suddivisi tra 2 destri e 2 sinistri. 7,5x45 Chevron è incastolato a 26 pezzi e all'interno di ciascuna scatola è garantita la presenza di almeno 12 coppie destro+sinistro. 20x120 Chevron and 20x120 Arch are boxed in 4 pieces per box, divided between 2 right and 2 left. 7,5x45 Chevron is boxed in 26 pieces and at least 12 right+left pairs are guaranteed inside each box. 20x120 Chevron et 20x120 Arch sont emballés en boîtes de 4 pièces, 2 droite et 2 gauche. 7,5x45 Chevron est emballé en boîtes de 26 pièces. Chaque boîte contient au moins 12 ensembles droite+gauche. 20x120 Chevron and 20x120 Arch werden in Kartons mit 4 Fliesen, jeweils 2 linke und 2 rechte, geliefert. 7,5x45 Chevron wird in Kartons mit 26 Fliesen geliefert. Jeder Karton enthält garantiert wenigstens 12 Paare aus rechter + linker Ausführung. 20x120 Chevron и 20x120 Arch упакованы по 4 штуки в коробку, разделенные на 2 правые и 2 левые. 7,5x45 Chevron упакован в коробку по 26 штук, и в каждой коробке гарантировано не менее 12 пар "правый+левый".

RT Rettificato, squadrato, monocalibro. - Rectified, squared, one caliber. - Rectifié, mis d'équerre et monocalibre. - Rektifiziert, rechtwinkelig und Ein kaliber. - Ректифицированный, одного калибра.

RET Rettificato. - Rectified. - Rectifié. - Rektifiziert. - Ректифицированный.

NR Non rettificato. - Not rectified. - Non rectifié. Nicht rektifiziert. - Не ретифицированный.

° Doga - Plank size - Lame - Diele - Доска

°° Listellato/Squares - Listel size/Squares - Multifrise/Squares - Leistenoptik/Squares - Эффект соединенных планок/Squares

Si raccomanda l'utilizzo di una fuga di 2/3 mm al fine di semplificare le operazioni di posa e ottimizzare la naturalezza del risultato finale. - We recommend you a 2/3 mm grout joint to simplify the laying and optimize the naturalness of the final result. - Un joint de 2/3 mm est conseillé afin de simplifier les opérations de pose et optimiser l'effet naturel du résultat final. - Es wird empfohlen mit einer Fuge von 2/3 mm zu arbeiten, um am Ende den Verlegevorgang zu vereinfachen und die bestmögliche Natürlichkeit der Arbeit zu erzielen. - Для облегчения операций укладки и повышения натуральности вида конечного результата рекомендуется выполнять шов шириной 2-3 мм.

Al fine di facilitare la manutenzione ordinaria si raccomanda di effettuare un lavaggio acido dopo 48 ore dalla stuccatura con un acido specifico per grès porcellanato. - In order to favour the ordinary maintenance procedures, it is recommended to carry out an acid wash of the surface after 48 hours from grout filling using an acid agent specific for porcelain stoneware tiles. - Afin de faciliter l'entretien ordinaire de votre carrelage, nous vous conseillons de le laver 48 heures après le colmatage des joints, avec un acide spécifique pour grès cérame. - Um die Instandhaltung zu erleichtern, empfiehlt es sich 48 Stunden nach der Stuckatur mit einer sauren Lösung speziell für Feinsteinzeug zu waschen. - Чтобы упростить уход за плиткой, спустя 48 часов после затирки швов рекомендуется выполнить обработку кислотным продуктом, пригодным для керамогранита.

CARATTERISTICHE TECNICHE

TILE PERFORMANCE DATA - NOTES TECHNIQUES - TECHNISCHE AUSKÜNFTE - ТЕХНИЧЕСКАЯ ХАРАКТЕРИСТИКА

Classificazione secondo EN ISO 14411 ISO 13006 annesso G gruppo Bla con Ev ≤0,5 % - Classification in accordance with EN ISO 14411 ISO 13006 annex G standards Bla with Ev ≤ 0,5% - Classification selon EN ISO 14411 ISO 13006 annexe G groupe Bla avec Ev ≤0,5% - Klassifizierung gemäß EN ISO 14411 ISO 13006 anlage G Gruppe Bla mit Ev ≤0,5% - Классификация в соответствии с EN ISO 14411 ISO 13006, приложение G, стандарт Bla, где Ev ≤0,5%

| | CARATTERISTICA TECNICA TECHNICAL CHARACTERISTIC CARACTERISTIQUE TECHNIQUE TECHNISCHE DATEN ТЕХНИЧЕСКАЯ ХАРАКТЕРИСТИКА | METODO DI PROVA TESTS METHOD METHODE D'ESSAI TESTMETHODE МЕТОД ИСПЫТАНИЯ | VALORE * MEDIO "CAESAR" AVERAGE "CAESAR" VALUE* VALEUR * MOYEN "CAESAR" "CAESAR" DURCHSCHNITTSWERT* СРЕДНЕЕ ЗНАЧЕНИЕ "CAESAR"* | VALORE * MEDIO "CAESAR" AVERAGE "CAESAR" VALUE A E X T R A 2 0 OPEN YOUR STYLE |
|--|--------------------------------------------------------------------------------------------------------------------------------------------------------------------------------------------------------------------------------------------|--------------------------------------------------------------------------------------|--------------------------------------------------------------------------------------------------------------------------------------------|---------------------------------------------------------------------------------------------------------------------------------------------------------------------------------------------------------------------------------------------------------------------------------------------------------------------------------------------|
| | Dimensione - Size Dimension - Abmessungen - Размер | ISO 10545-2 | Conforme - In accordance Conforme - Erfüllt - Соответствует | Conforme - In accordance Conforme - Erfüllt - Соответствует |
| | Assorbimento d'acqua* - Water absorption* Absorption d'eau* - Wasseraufnahme* - % Поглощения воды* | ISO 10545-3 | ≤ 0,1% | ≤ 0,1% |
| | Resistenza alla flessione* - Bending strength* Résistance à la flexion* - Biegezugfestigkeit* - Упругость* | ISO 10545-4 | Conforme - In accordance Conforme - Erfüllt - Соответствует | Non applicabile a piastrelle con una forza di rottura ≥ 3000 N Not applicable to tiles with a breaking strength ≥ 3000 N N'est pas applicable aux carreaux avec une charge de rupture ≥ 3000 N Nicht anwendbar bei Fliesen mit einer Bruchlast ≥ 3000 N Не применяется в отношении плиток с прочностью на изрыв ≥ 3000 N |
| | Sforzo di rottura (S) - Breaking strength Charge de rupture - Bruchlast - Разрушающее усилие | ISO 10545-4 | Sps ≥ 7,5 mm S ≥ 1300 N | > 10.000 N |
| | Resistenza all'abrasione profonda* - Deep scratch resistance* Résistance à l'abrasion profonde* - Widerstand gegen Tiefenverschleiß* Устойчивость глубокому истиранию* | ISO 10545-6 | Conforme - In accordance Conforme - Erfüllt - Соответствует | Conforme - In accordance Conforme - Erfüllt - Соответствует |
| | Coefficiente di dilatazione termica lineare* - Thermal linear expansion coefficient* Coefficient de dilatation thermique linéaire* - Koeffizient der linearen thermischen Dehnung* - Коэффициент линейного теплового расширения* | ISO 10545-8 | ≈ 7 (10 ⁻⁶ °C ⁻¹) | ≈ 7 (10 ⁻⁶ °C ⁻¹) |
| | Resistenza agli sbalzi termici* - Thermal shock resistance* Résistance aux écarts de température* - Temperaturwechsel Beständigkeit* Устойчивость к тепловому перепаду* | ISO 10545-9 | Resistente - Resistant Résistante - Beständig - Стойкий | Resistente - Resistant Résistante - Beständig - Стойкий |
| | Dilatazione all'umidità* - Expansion in humidity* Dilatation à l'humidité* - Feuchtigkeitsausdehnung* Расширение в условиях влажности* | ISO 10545-10 | ≤ 0,1 (mm/m) | ≤ 0,1 (mm/m) |
| | Resistenza al gelo* - Frost resistance* Résistance au gel* - Frostbeständigkeit* - Морозостойчивость* | ISO 10545-12 | Resistente - Resistant Résistante - Beständig - Стойкий | Resistente - Resistant Résistante - Beständig - Стойкий |
| | Resistenza all'attacco chimico* - Resistance to chemical attack* Résistance à l'attaque chimique* - Beständigkeit gegen Chemikalien* Устойчивость к химическому воздействию* | ISO 10545-13 | Resistente - Resistant Résistante - Beständig - Стойкий | Resistente - Resistant Résistante - Beständig - Стойкий |
| | Carico statico - Static load Charge statique - Statische Last Статическая нагрузка | EN 12825 | - | 60x60 KN>7,0 30x120 KN>3,0 |
| | Classe di carico di rottura*** - Breaking load class*** Classe de charge de rupture*** - Bruchlastklasse*** Класс стойкости к разрушающей нагрузке*** | EN 1339 | - | Centro - Centre - Au centre - Mitte - По центру KN>5,0 Centro lato - Side centre - Au centre latéralement Mitte Seite - По центру грани KN>3,0 Diagonale - Diagonal - En diagonale Diagonal - По диагонали KN>8,0 KN>6,5 |
| | Resistenza alle macchie* - Resistance to stains* Résistance aux taches* - Fleckenbeständigkeit* Устойчивость к образованию пятен* | ISO 10545-14 | Pulibile - Cleanable Nettoyable - Leicht zu reinigen Чистящийся | U11 T11 Pulibile - Cleanable Nettoyable - Leicht zu reinigen Чистящийся |
| | Resistenza allo scivolamento** - Slip resistance** Résistance au glissement** - Rutschhemmende Eigenschaft** Сопротивление скольжению** | DIN 51130 - DIN 51097 | R9 A Matt R11 C Grip | R11 C |
| | Spessore nominale - Nominal Thickness Épaisseur nominale - Nominalstärke Номинальная толщина | ▲ ANSI A326.3 | Wet DCOF ≥ 0,42 Wet DCOF ≥ 0,55 | Wet DCOF ≥ 0,55 |
| | | | 9 mm | 20 mm |

* Valori medi riferiti agli ultimi due anni di produzione e relativi alla finitura naturale del prodotto - Average values referred to the last two years of production and related to the matt finish of the product - Valeurs moyennes des deux dernières années de production et relatifs à la finition naturelle du produit - Durchschnittswerte, die sich auf die letzten zwei Produktionsjahre beziehen und auf die matte Oberfläche - Средние значения относятся к последним двум годам производства и натуральной отделке поверхности

** Valori relativi alla finitura naturale del prodotto ed a test effettuati da laboratori esterni accreditati, disponibili in azienda; ci rendiamo disponibili alla verifica dell'eventuale lotto interessato all'acquisto. - As far as values relating to the matt finish of the product and to tests carried out by certified external laboratories whose results are available upon request at Headoffice, we are willing to check the lot you are interested in purchasing. - Valeurs se référant à la finition naturelle du produit selon des tests effectués par des laboratoires extérieurs accrédités et à la disposition de toute personne intéressée auprès de nos bureaux; nous sommes disponibles pour le contrôle de l'éventuel lot concerné par l'achat. - Werte bezogen auf das natürliche Produktfinish und in anerkannten externen Labors geprüft, im Unternehmen erhältlich; für eventuelle Prüfungen der zu erwerbenden Warenposten stehen wir gern zur Verfügung. - Значения, касающиеся натуральных характеристик изделий и тестов, выполненных внешними авторизованными лабораториями, имеются в компании. Мы готовы выполнить проверку партии товара, которую намереваетесь приобрести.

*** Dato riferito al formato 60x60 cm. - Detail referred to the 60x60 cm size. - Donnée se rapportant au format 60x60 cm. - Auf die Formate 60x60 cm bezogen. - Значения, касающиеся натуральных характеристик изделий и тестов.

• Per prodotti chimici di uso domestico e additivi per piscina. - For domestic chemicals and swimming pool additives. - Pour produits chimiques à usage domestique et additifs pour piscines. - Für chemische Produkte für den Hausgebrauch und Schwimmbadzusätze. - Для бытовых химикатов и добавок для бассейнов.

▲ Valori wet DCOF specifici disponibili in azienda - Wet DCOF specific values available at the company - Valeurs wet DCOF spécifiques disponibles à l'usine - Prüfwerte Wet DCOF stehen im Werk zur Verfügung - Показатели wet DCOF доступны при запросе

Le tonalità dei campioni sono da considerarsi puramente indicative. - Tones of samples are indicative. - Les tonalités des échantillons sont purement indicatives. Die farbtöne der Muster sind als rein produktiv zu betrachten. - Тона образцов ориентировочные.

Fabula

The wonder of woods



Fabula è il racconto di una storia meravigliosa, che comincia con la scoperta di tre legni estremamente pregiati e prosegue con la loro fedele riproduzione. Il risultato è una collezione in grès porcellanato da sogno, ideale per infondere una calda e naturale eleganza ai più svariati contesti di architettura e design.

Fabula tells an amazing tale, which begins with the discovery of three extremely precious kinds of wood and continues with their faithful portrayal. The result is a collection of porcelain stoneware that makes your dreams come true. Ideal for instilling warmth and natural elegance to the most diverse architectural contexts.

Fabula est le récit d'une histoire merveilleuse, qui commence par la découverte de trois bois de très haute qualité et se poursuit par leur reproduction fidèle. Le résultat est une fabuleuse collection en grès cérame, idéale pour donner une élégance naturelle et chaleureuse aux multiples contextes d'architecture et de design.

Fabula erzählt eine wunderschöne Geschichte, die mit der Entdeckung von drei extrem kostbaren Hölzern beginnt und mit ihrer getreuen Nachgestaltung fortsetzt. Das Ergebnis ist eine traumhafte Feinsteinzeug-Kollektion, die den unterschiedlichsten Architektur- und Designkontexten eine warme und natürliche Eleganz verleiht.

Fabula - это коллекция, рассказывающая завораживающую историю. Она начинается с открытия три чрезвычайно ценных пород дерева, и продолжается их точным воспроизведением. В результате получается чудесная линейка керамогранита, очень удачно вносящая штрих теплой и естественной элегантности в самые разнообразные архитектурные и дизайнерские окружения.



Info
Resources
Tools



WOOD LOOK

Floor: **ROBUR 20x120 Chevron MATT RET, ROBUR 20x120 MATT RT**
Wall: **ROBUR 5,7x60 MATT RT**

Fabula



WOOD LOOK

Colori - Formati

Colors - Sizes

20x120 . 5,7x60 9 mm MATT RT
20x120 CHEVRON 9 mm MATT RET

ROBUR



ULMUS



THECA



9 mm



20x120
7⁷/₈"x47²/₈"



5,7x60
2²/₈"x23²/₈"

MATT RT

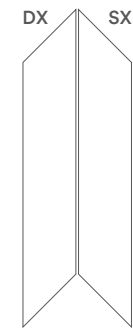

20x120 CHEVRON
7⁷/₈"x47²/₈"

MATT RET

La gamma

The range

ROBUR

ULMUS

THECA



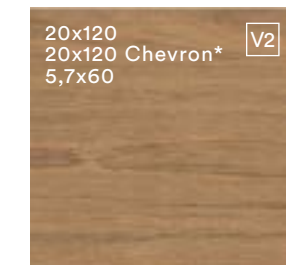
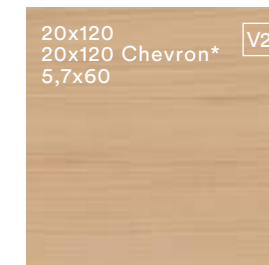
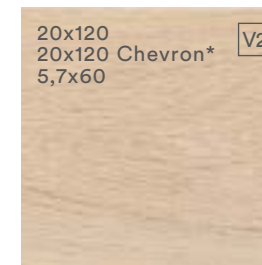

MATT RT
MATT RET*



*La liste a jour des produits et formats des series certifiees QB-UPEC est disponible en usine.

RT Rettificato, squadrato, monocalibro. - Rectified, squared, one caliber. - Rectifié, mis d'équerre et monocalibre. - Rektifiziert, rechtwinkelig und Ein kaliber. - Ректифицированный, одного калибра.
RET Rettificato. - Rectified. - Rectifié. - Rektifiziert. - Ректифицированный.



| |  20x120 cm 7 ⁷ / ₈ "x47 ⁷ / ₈ " 9 mm MATT RT |  20x120 cm Chevron 7 ⁷ / ₈ "x47 ⁷ / ₈ " 9 mm MATT RET |  5,7x60 cm 2 ² / ₈ "x23 ⁵ / ₈ " 9 mm MATT RT |  Battiscopa - Bullnose Plinthe - Sockel Плинтус 6,2x60 cm 2 ⁷ / ₈ "x23 ⁵ / ₈ " MATT |
|-------|------------------------------------------------------------------------------------------------------------------------------------------------------------------------------------------------|---------------------------------------------------------------------------------------------------------------------------------------------------------------------------------------------------------|-------------------------------------------------------------------------------------------------------------------------------------------------------------------------------------------------|-----------------------------------------------------------------------------------------------------------------------------------------------------------------------------------------------------------------------------------------------|
| Robur | ● | ● | ● | ● |
| Ulmus | ● | ● | ● | ● |
| Theca | ● | ● | ● | ● |

IMBALLI - PACKAGING - CONDITIONNEMENT - VERPACKUNGS-EINHEITEN - УПАКОВКА

| Formato - Size - Format - Формат | | Scatola - Box - Boîte - Karton - Коробка | | | Pallet - Palette - Палета | | |
|----------------------------------|------------------------------------------------------------------|------------------------------------------|-------|--------|---------------------------|--------|---------|
| CM | INCHES | PZ | MQ | KG | SC | MQ | KG |
| 20x120 | 7 ⁷ / ₈ "x47 ⁷ / ₈ " | 6 | 1,44 | ~31,10 | 32 | 46,08 | ~995,20 |
| 20x120 Chevron | 7 ⁷ / ₈ "x47 ⁷ / ₈ " | 4 | 0,80 | ~17,20 | 40 | 32,00 | ~688,00 |
| 5,7x60 | 2 ² / ₈ "x23 ⁵ / ₈ " | 16 | 0,547 | ~12,80 | 64 | 35,008 | ~819,20 |

20x120 Chevron è incastolato a 4 pezzi per scatola, suddivisi tra 2 destri e 2 sinistri. - 20x120 Chevron is packed in boxes containing 4 pieces each, 2 left and 2 right. - Les carreaux 20x120 Chevron sont conditionnés 4 par 4, 2 droites et 2 gauches. - 20x120 Chevron ist in Kartons mit jeweils 4 Fliesen, 2 rechten und 2 linken, verpackt. - 20x120 Chevron упаковывается по 4 штуки на коробку, 2 правые и 2 левые.

RT Rettificato, squadrato, monocalibro. - Rectified, squared, one caliber. - Rectifié, mis d'équerre et monocalibre. - Rektifiziert, rechtwinkelig und Ein kaliber. - Ректифицированный, одного калибра.
 RET Rettificato. - Rectified. - Rektifiziert. - Ректифицированный.













Si raccomanda l'utilizzo di una fuga di 2/3 mm al fine di semplificare le operazioni di posa e ottimizzare la naturalezza del risultato finale. - We recommend you a 2/3 mm grout joint to simplify the laying and optimize the naturalness of the final result. - Un joint de 2/3 mm est conseillé afin de simplifier les opérations de pose et optimiser l'effet naturel du résultat final. - Es wird empfohlen mit einer Fuge von 2/3 mm zu arbeiten, um am Ende den Verlegevorgang zu vereinfachen und die bestmögliche Natürlichkeit der Arbeit zu erzielen. - Для облегчения операций укладки и повышения натуральности вида конечного результата рекомендуется выполнять шов шириной 2-3 мм.

Al fine di facilitare la manutenzione ordinaria si raccomanda di effettuare un lavaggio acido dopo 48 ore dalla stuccatura con un acido specifico per grès porcellanato. - In order to favour the ordinary maintenance procedures, it is recommended to carry out an acid wash of the surface after 48 hours from grout filling using an acid agent specific for porcelain stoneware tiles. - Afin de faciliter l'entretien ordinaire de votre carrelage, nous vous conseillons de le laver 48 heures après le colmatage des joints, avec un acide spécifique pour grès cérame. - Um die Instandhaltung zu erleichtern, empfiehlt es sich 48 Stunden nach der Stuckatur mit einer sauren Lösung speziell für Feinsteinzeug zu waschen. - Чтобы упростить уход за плиткой, спустя 48 часов после затирки швов рекомендуется выполнить обработку кислотным продуктом, пригодным для керамогранита.

CARATTERISTICHE TECNICHE

TILE PERFORMANCE DATA - NOTES TECHNIQUES - TECHNISCHE AUSKÜNFTE - ТЕХНИЧЕСКАЯ ХАРАКТЕРИСТИКА

Classificazione secondo EN ISO 14411 ISO 13006 annesso G gruppo Bla con Ev ≤0,5 % - Classification in accordance with EN ISO 14411 ISO 13006 annex G standards Bla with Ev ≤ 0,5% - Classification selon EN ISO 14411 ISO 13006 annexe G groupe Bla avec Ev ≤0,5% - Klassifizierung gemäß EN ISO 14411 ISO 13006 anlage G Gruppe Bla mit Ev ≤0,5% - Классификация в соответствии с EN ISO 14411 ISO 13006, приложение G, стандарт Bla, где Ev ≤0,5%

| | CARATTERISTICA TECNICA TECHNICAL CHARACTERISTIC CARACTERISTIQUE TECHNIQUE TECHNISCHE DATEN ТЕХНИЧЕСКАЯ ХАРАКТЕРИСТИКА | METODO DI PROVA TESTS METHOD METHODE D'ESSAI TESTMETHODE МЕТОД ИСПЫТАНИЯ | VALORE * MEDIO "CAESAR" AVERAGE "CAESAR" VALUE* VALEUR * MOYEN "CAESAR" "CAESAR" DURCHSCHNITTSWERT* СРЕДНЕЕ ЗНАЧЕНИЕ "CAESAR"* |
|---------------------------------------------------------------------------------------|-------------------------------------------------------------------------------------------------------------------------------------------------------------------------------------------------------------------------------------|--------------------------------------------------------------------------------------|--------------------------------------------------------------------------------------------------------------------------------------------|
|  | Dimensione - Size Dimension - Abmessungen - Размер | ISO 10545-2 | Conforme - In accordance Conforme - Erfüllt - Соответствует |
|  | Assorbimento d'acqua* - Water absorption* Absorption d'eau* - Wasseraufnahme* - % Поглощения воды* | ISO 10545-3 | ≤ 0,1% |
|  | Resistenza alla flessione* - Bending strength* Résistance à la flexion* - Biegezugfestigkeit* - Упругость* | ISO 10545-4 | Conforme - In accordance Conforme - Erfüllt - Соответствует |
|  | Resistenza all'abrasione profonda* - Deep scratch resistance* Résistance à l'abrasion profonde* - Widerstand gegen Tiefenverschleiß* Устойчивость глубокому истиранию* | ISO 10545-6 | Conforme - In accordance Conforme - Erfüllt - Соответствует |
|  | Coefficiente di dilatazione termica lineare* - Thermal linear expansion coefficient* Coefficient de dilatation thermique linéaire* - Koeffizient der linearen thermischen Dehnung* - Коэффициент линейного теплового расширения* | ISO 10545-8 | = 7 (10 ⁻⁶ °C ⁻¹) |
|  | Resistenza agli sbalzi termici* - Thermal shock resistance* Résistance aux écarts de température* - Temperaturwechsel Beständigkeit* Устойчивость к тепловому перепаду* | ISO 10545-9 | Resistente - Resistant Résistante - Beständig - Стойкий |
|  | Dilatazione all'umidità* - Expansion in humidity* Dilatation à l'humidité* - Feuchtigkeitsausdehnung* Расширение в условиях влажности* | ISO 10545-10 | ≤ 0,1 (mm/m) |
|  | Resistenza al gelo* - Frost resistance* Résistance au gel* - Frostbeständigkeit* - Морозоустойчивость* | ISO 10545-12 | Resistente - Resistant Résistante - Beständig - Стойкий |
|  | Resistenza all'attacco chimico* - Resistance to chemical attack* Résistance à l'attaque chimique* - Beständigkeit gegen Chemikalien* Устойчивость к химическому воздействию* | ISO 10545-13 | Resistente - Resistant Résistante - Beständig - Стойкий |
|  | Resistenza alle macchie* - Resistance to stains* Résistance aux taches* - Fleckenbeständigkeit* Устойчивость к образованию пятен* | ISO 10545-14 | Pulibile - Cleanable Nettoyable - Leicht zu reinigen Чистящийся |
|  | Resistenza allo scivolamento** - Slip resistance** Résistance au glissement** - Rutschhemmende Eigenschaft** Сопротивление скольжению** | DIN 51130 - DIN 51097 ▲ ANSI A326.3 | R9 Matt Wet DCOF ≥ 0,42 |
|  | Spessore nominale - Nominal Thickness Épaisseur nominal - Nominalstärke Номинальная толщина | | 9 mm |

* Valori medi riferiti agli ultimi due anni di produzione e relativi alla finitura naturale del prodotto - Average values referred to the last two years of production and related to the matt finish of the product - Valeurs moyennes des deux dernières années de production et relatifs à la finition naturelle du produit - Durchschnittswerte, die sich auf die letzten zwei Produktionsjahre beziehen und auf die matte Oberfläche - Средние значения относятся к последним двум годам производства и натуральной отделке поверхности

** Valori relativi alla finitura naturale del prodotto ed a test effettuati da laboratori esterni accreditati, disponibili in azienda; ci rendiamo disponibili alla verifica dell'eventuale lotto interessato all'acquisto. - As far as values relating to the matt finish of the product and to tests carried out by certified external laboratories whose results are available upon request at Headoffice, we are willing to check the lot you are interested in purchasing. - Valeurs se référant à la finition naturelle du produit selon des tests effectués par des laboratoires extérieurs accrédités et à la disposition de toute personne intéressée auprès de nos bureaux; nous sommes disponibles pour le contrôle de l'éventuel lot concerné par l'achat. - Werte bezogen auf das natürliche Produktfinish und in anerkannten externen Labors geprüft, im Unternehmen erhältlich; für eventuelle Prüfungen der zu erwerbenden Warenposten stehen wir gern zur Verfügung. - Значения, касающиеся натуральных характеристик изделий и тестов, выполненных внешними авторизованными лабораториями, имеются компании. Мы готовы выполнить проверку партии товара, которую намереваетесь приобрести.

• Per prodotti chimici di uso domestico e additivi per piscina. - For domestic chemicals and swimming pool additives. - Pour produits chimiques à usage domestique et additifs pour piscines. - Für chemische Produkte für den Hausgebrauch und Schwimmbadzusätze. - Для бытовых химикатов и добавок для бассейнов.

▲ Valori wet DCOF specifici disponibili in azienda - Wet DCOF specific values available at the company - Valeurs wet DCOF spécifiques disponibles à l'usine - Prüfwerte Wet DCOF stehen im Werk zur Verfügung - Показатели wet DCOF доступны при запросе

Le tonalità dei campioni sono da considerarsi puramente indicative. - Tones of samples are indicative. - Les tonalités des échantillons sont purement indicatives. Die Farbtöne der Muster sind als rein indicativ zu betrachten. - Тона образцов ориентировочные.

Hike

Your natural architecture



Calore, armonia, eleganza naturale: con Hike il grès porcellanato si lascia conquistare dal fascino irresistibile del legno per donare agli spazi un mood accogliente e positivo. Superfici dalle sfumature delicate, sempre vicine alla tua vita di ogni giorno, che vivono e respirano insieme a te e ti fanno sentire in equilibrio, al centro perfetto del tuo mondo ideale.

Warmth, harmony, natural elegance: Hike is the porcelain stoneware that surrenders to the irresistible charm of wood to give your spaces a cosy and positive mood. Surfaces with delicate shades, which are always near to your everyday life, which live and breath in harmony with you, to make you feel at the centre of your ideal world.

Chaleur, harmonie et élégance naturelle : avec Hike le grès cérame succombe au charme irrésistible du bois pour des atmosphères douillettes et accueillantes. Des surfaces aux nuances délicates, toujours proches de votre vie quotidienne, qui vivent et respirent à votre rythme, dans la sérénité, au cœur de votre monde.

Wärme, Harmonie, natürliche Eleganz: Hike ist ein Feinsteinzeug, das die berückende Faszination des Holzes ausstrahlt und dem Raum eine positive, behagliche Atmosphäre verleiht. Oberflächen mit zarten Nuancen, die Sie an allen Tagen begleiten, die mit Ihnen leben und atmen und ein Gefühl des Gleichgewichts entstehen lassen, ganz im Einklang mit Ihrer idealen Welt.

Тепло, гармония, естественная элегантность: в коллекции Hike керамогранит отдается во власть неотразимого очарования дерева, чтобы наполнить пространства уютом и позитивом. Поверхности с деликатными оттенками, сопровождающие вас в повседневной жизни, живут и дышат вместе с вами и позволяют почувствовать равновесие, строго по центру вашего идеального мира.



Info
Resources
Tools



Floor : LODGE 20x120 MATT RT
Wall : LODGE 20x120 GRIP RT R11 B

Colori - Formati

Colors - Sizes

- 20x120 9 mm MATT RT
- 20x120 CHEVRON 9 mm MATT RET
- 20x120 9 mm GRIP RT R11 B
- 30x120 . 60x60 20 mm AEXTRA20 RT R11 C

LIGHT



NUANCE



LODGE



LUMBER



9 mm



20x120
7⁷/₈"x47⁵/₈"

MATT RT

MATT RET

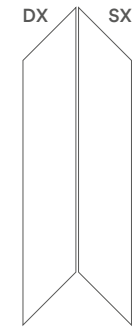

20x120 CHEVRON
7⁷/₈"x47⁵/₈"

9 mm



20x120
7⁷/₈"x47⁵/₈"

GRIP RT R11B

20 mm



30x120
11⁵/₈"x47⁵/₈"



60x60
23⁵/₈"x23⁵/₈"

AEXTRA20 RT R11 C

*La liste à jour des produits et formats des series certifiées QB-UPEC est disponible en usine.

Hike

La gamma

The range

LIGHT

NUANCE

LODGE

LUMBER



MATT RT
MATT RET*

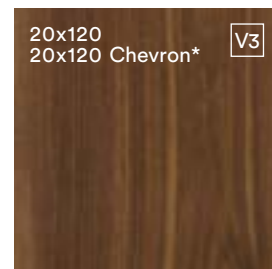
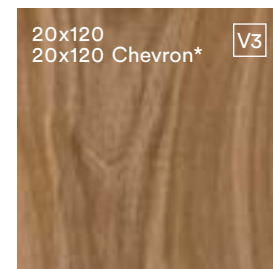
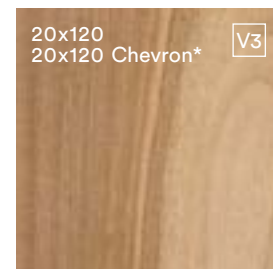

GRIP RT R11 B

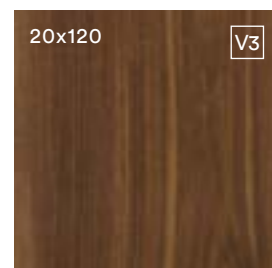
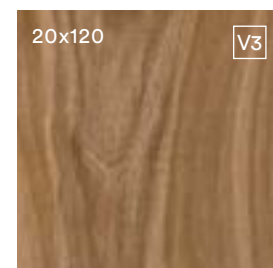
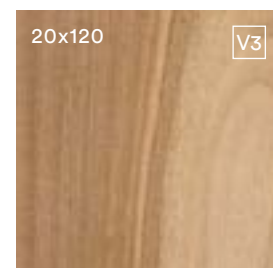

AEXTRA20 RT R11 C

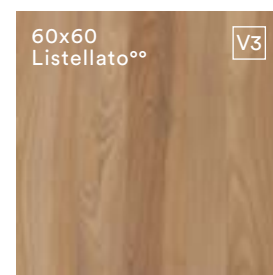
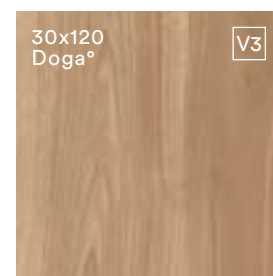

* Doga - Plank size - Lame - Diele - Доска

°° Listellato - Listel size - Multifrise - Leistenoptik - Эффект соединенных планок

Nei formati 80x80 e 60x60 l'estetica dei prodotti richiama doghe accostate tra loro o un look a cassettoni, mentre nel formato 30x120 viene riprodotta soltanto la texture del legno. - In the 80x80 and 60x60 sizes, the styling of the products recalls planks placed side-by-side or a coffered look, while the 30x120 size reproduces the texture of wood alone. - Dans les formats 80x80 et 60x60 l'esthétique des produits rappelle des listels ou un aspect à caissons alors que le format 30x120 reproduit uniquement la texture du bois. - In den Formaten 80x80 und 60x60 Verweist die Optik der Produkte auf Aneinandergelegte Dielen Oder auf Ein Kassettenmotiv, während im Format 30x120 nur die Struktur des Holzes wiedergegeben wird. - В форматах 80x80 и 60x60 эстетика плитки напоминает размещенные рядом доски или кесонный потолок, в то время как в формате 30x120 воспроизводится только текстура дерева.

RT Rettificato, quadrato, monocalibro. - Rectified, squared, one caliber. - Rectifié, mis d'équerre et monocalibre. - Rektifiziert, rechtwinkelig und Ein kaliber. - Ректифицированный, одного калибра.

RET Rettificato. - Rectified. - Rectifié. - Rektifiziert. - Ректифицированный.



WOOD LOOK



| | A E X T R A 2 0 | | A E X T R A 2 0 | | A E X T R A 2 0 | |
|--------|---------------------------------------|-----------------------------------------------|---------------------------------------------------------|-------------------------------------------------------|------------------------------------------------------|--|
| | 20x120 cm 7 7/8" x 47 7/8" 9 mm | 20x120 cm Chevron 7 7/8" x 47 7/8" 9 mm | 30x120 cm ° 11 13/16" x 47 7/8" 20 mm RT R11 C | 60x60 cm °° 23 5/8" x 23 5/8" 20 mm RT R11 C | Battiscopa - Bullnose Plinthe - Sockel Плинтус | |
| | MATT RT | GRIP RT R11 B | MATT RET | | MATT | |
| Light | ● | | ● | | ● | |
| Nuance | ● | ● | ● | ● | ● | |
| Lodge | ● | ● | ● | ● | ● | |
| Lumber | ● | ● | ● | | ● | |

| IMBALLI - PACKAGING - CONDITIONNEMENT - VERPACKUNGS-EINHEITEN - УПАКОВКА | | | | | | | |
|--------------------------------------------------------------------------|---------------------|------------------------------------------|------|--------|---------------------------|-------|----------|
| Formato - Size - Format - Формат | | Scatola - Box - Boîte - Karton - Коробка | | | Pallet - Palette - Палета | | |
| CM | INCHES | PZ | MQ | KG | SC | MQ | KG |
| 20x120 | 7 7/8" x 47 7/8" | 6 | 1,44 | ~31,10 | 32 | 46,08 | ~995,20 |
| 20x120 Chevron | 7 7/8" x 47 7/8" | 4 | 0,80 | ~17,20 | 40 | 32,00 | ~688,00 |
| 60x60 A E X T R A 2 0 | 23 5/8" x 23 5/8" | 2 | 0,72 | ~32,00 | 30 | 21,60 | ~960,00 |
| 30x120 A E X T R A 2 0 | 11 13/16" x 47 7/8" | 2 | 0,72 | ~33,35 | 36 | 25,92 | ~1200,60 |

20x120 Chevron è incastolato a 4 pezzi per scatola, suddivisi tra 2 destri e 2 sinistri. - 20x120 Chevron is packed in boxes containing 4 pieces each, 2 left and 2 right. - Les carreaux 20x120 Chevron sont conditionnés 4 par 4, 2 droits et 2 gauches. - 20x120 Chevron ist in Kartons mit jeweils 4 Fliesen, 2 rechten und 2 linken, verpackt. - 20x120 Chevron упаковывается по 4 штуки на коробку, 2 правые и 2 левые.

RT Rettificato, quadrato, monocalibro. - Rectified, squared, one caliber. - Rectifié, mis d'équerre et monocalibre. - Rektifiziert, rechtwinkelig und Ein kaliber. - Ректифицированный, одного калибра.

RET Rettificato. - Rectified. - Rectifié. - Rektifiziert. - Ректифицированный.

° Doga - Plank size - Lame - Diele - Доска

°° Listellato/Squares - Listel size/Squares - Multifrise/Squares - Leistenoptik/Squares - Эффект соединенных планок/Squares

Si raccomanda l'utilizzo di una fuga di 2/3 mm al fine di semplificare le operazioni di posa e ottimizzare la naturalezza del risultato finale. - We recommend you a 2/3 mm grout joint to simplify the laying and optimize the naturalness of the final result. - Un joint de 2/3 mm est conseillé afin de simplifier les opérations de pose et optimiser l'effet naturel du résultat final. - Es wird empfohlen mit einer Fuge von 2/3 mm zu arbeiten, um am Ende den Verlegevorgang zu vereinfachen und die bestmögliche Natürlichkeit der Arbeit zu erzielen. - Для облегчения операций укладки и повышения натуральности вида конечного результата рекомендуется выполнять шов шириной 2-3 мм.

Al fine di facilitare la manutenzione ordinaria si raccomanda di effettuare un lavaggio acido dopo 48 ore dalla stuccatura con un acido specifico per grès porcellanato. - In order to favour the ordinary maintenance procedures, it is recommended to carry out an acid wash of the surface after 48 hours from grout filling using an acid agent specific for porcelain stoneware tiles. - Afin de faciliter l'entretien ordinaire de votre carrelage, nous vous conseillons de le laver 48 heures après le colmatage des joints, avec un acide spécifique pour grès cérame. - Um die Instandhaltung zu erleichtern, empfiehlt es sich 48 Stunden nach der Stuckatur mit einer sauren Lösung speziell für Feinsteinzeug zu waschen. - Чтобы упростить уход за плиткой, спустя 48 часов после затирки швов рекомендуется выполнить обработку кислотным продуктом, пригодным для керамогранита.

CARATTERISTICHE TECNICHE

TILE PERFORMANCE DATA - NOTES TECHNIQUES - TECHNISCHE AUSKÜNFTE - ТЕХНИЧЕСКАЯ ХАРАКТЕРИСТИКА

Classificazione secondo EN ISO 14411 ISO 13006 annesso G gruppo Bla con Ev ≤0,5% - Classification in accordance with EN ISO 14411 ISO 13006 annex G standards Bla with Ev ≤ 0,5% - Classification selon EN ISO 14411 ISO 13006 annexe G groupe Bla avec Ev ≤0,5% - Klassifizierung gemäß EN ISO 14411 ISO 13006 anlage G Gruppe Bla mit Ev ≤0,5% - Классификация в соответствии с EN ISO 14411 ISO 13006, приложение G, стандарт Bla, где Ev ≤0,5%

| | CARATTERISTICA TECNICA TECHNICAL CHARACTERISTIC CARACTERISTIQUE TECHNIQUE TECHNISCHE DATEN ТЕХНИЧЕСКАЯ ХАРАКТЕРИСТИКА | METODO DI PROVA TESTS METHOD METHODE D'ESSAI TESTMETHODE МЕТОД ИСПЫТАНИЯ | VALORE * MEDIO "CAESAR" AVERAGE "CAESAR" VALUE* VALEUR * MOYEN "CAESAR" "CAESAR" DURCHSCHNITTSWERT* СРЕДНЕЕ ЗНАЧЕНИЕ "CAESAR"* | VALORE * MEDIO "CAESAR" AVERAGE "CAESAR" VALUE A E X T R A 2 0 OPEN YOUR STYLE |
|--|-------------------------------------------------------------------------------------------------------------------------------------------------------------------------------------------------------------------------------------|--------------------------------------------------------------------------------------|--------------------------------------------------------------------------------------------------------------------------------------------|-----------------------------------------------------------------------------------------------------------------------------------------------------------------------------------------------------------------------------------------------------------------------------------------------------------------------------|
| | Dimensione - Size Dimension - Abmessungen - Размер | ISO 10545-2 | Conforme - In accordance Conforme - Erfüllt - Соответствует | Conforme - In accordance Conforme - Erfüllt - Соответствует |
| | Assorbimento d'acqua* - Water absorption* Absorption d'eau* - Wasseraufnahme* - % Поглощения воды* | ISO 10545-3 | ≤ 0,1% | ≤ 0,1% |
| | Resistenza alla flessione* - Bending strength* Résistance à la flexion* - Biegezugfestigkeit* - Упругость* | ISO 10545-4 | Conforme - In accordance Conforme - Erfüllt - Соответствует | Non applicabile a piastrelle con una forza di rottura Not applicable to tiles with a breaking strength N'est pas applicable aux carreaux avec une charge de rupture Nicht anwendbar bei Fliesen mit einer Bruchlast Не применяется в отношении плиток с прочностью на изрыв ≥ 3000 N ≥ 3000 N ≥ 3000 N |
| | Sforzo di rottura (S) - Breaking strength Charge de rupture - Bruchlast - Разрушающее усилие | ISO 10545-4 | Sps ≥ 7,5 mm S ≥ 1300 N | > 10.000 N |
| | Resistenza all'abrasione profonda* - Deep scratch resistance* Résistance à l'abrasion profonde* - Widerstand gegen Tiefenverschleiß* Устойчивость глубокому истиранию* | ISO 10545-6 | Conforme - In accordance Conforme - Erfüllt - Соответствует | Conforme - In accordance Conforme - Erfüllt - Соответствует |
| | Coefficiente di dilatazione termica lineare* - Thermal linear expansion coefficient* Coefficient de dilatation thermique linéaire* - Koeffizient der linearen thermischen Dehnung* - Коэффициент линейного теплового расширения* | ISO 10545-8 | ≈ 7 (10 ⁻⁶ °C ⁻¹) | ≈ 7 (10 ⁻⁶ °C ⁻¹) |
| | Resistenza agli sbalzi termici* - Thermal shock resistance* Résistance aux écarts de température* - Temperaturwechsel Beständigkeit* Устойчивость к тепловому перепаду* | ISO 10545-9 | Resistente - Resistant Résistante - Beständig - Стойкий | Resistente - Resistant Résistante - Beständig - Стойкий |
| | Dilatazione all'umidità* - Expansion in humidity* Dilatation à l'humidité* - Feuchtigkeitsausdehnung* Расширение в условиях влажности* | ISO 10545-10 | ≤ 0,1 (mm/m) | ≤ 0,1 (mm/m) |
| | Resistenza al gelo* - Frost resistance* Résistance au gel* - Frostbeständigkeit* - Морозоустойчивость* | ISO 10545-12 | Resistente - Resistant Résistante - Beständig - Стойкий | Resistente - Resistant Résistante - Beständig - Стойкий |
| | Resistenza all'attacco chimico* - Resistance to chemical attack* Résistance à l'attaque chimique* - Beständigkeit gegen Chemikalien* Устойчивость к химическому воздействию* | ISO 10545-13 | Resistente - Resistant Résistante - Beständig - Стойкий | Resistente - Resistant Résistante - Beständig - Стойкий |
| | Carico statico - Static load Charge statique - Statische Last Статическая нагрузка | EN 12825 | - | 60x60 KN>7,0 30x120 KN>3,0 |
| | Carico statico - Static load Charge statique - Statische Last Статическая нагрузка | EN 12825 | - | Centro lato - Side centre - Au centre latéralement Mitte Seite - По центру грани Diagonale - Diagonal - En diagonale Diagonal - По диагонали KN>5,0 KN>3,0 KN>8,0 KN>6,5 |
| | Classe di carico di rottura*** - Breaking load class*** Classe de charge de rupture*** - Bruchlastklasse*** Класс стойкости к разрушающей нагрузке*** | EN 1339 | - | U11 |
| | Resistenza alle macchie* - Resistance to stains* Résistance aux taches* - Fleckenbeständigkeit* Устойчивость к образованию пятен* | ISO 10545-14 | Pulibile - Cleanable Nettoyable - Leicht zu reinigen Чистящийся | T11 Pulibile - Cleanable Nettoyable - Leicht zu reinigen Чистящийся |
| | Resistenza allo scivolamento** - Slip resistance** Résistance au glissement** - Rutschhemmende Eigenschaft** Сопротивление скольжению** | DIN 51130 - DIN 51097 | R9 Matt Wet DCOF ≥ 0,42 | R11 B Grip Wet DCOF ≥ 0,55 |
| | Spessore nominale - Nominal Thickness Épaisseur nominal - Nominalstärke Номинальная толщина | | 9 mm | Wet DCOF ≥ 0,55 20 mm |

* Valori medi riferiti agli ultimi due anni di produzione e relativi alla finitura naturale del prodotto - Average values referred to the last two years of production and related to the matt finish of the product - Valeurs moyennes des deux dernières années de production et relatifs à la finition naturelle du produit - Durchschnittswerte, die sich auf die letzten zwei Produktionsjahre beziehen und auf die matte Oberfläche - Средние значения относятся к последним двум годам производства и натуральной отделке поверхности

** Valori relativi alla finitura naturale del prodotto ed a test effettuati da laboratori esterni accreditati, disponibili in azienda; ci rendiamo disponibili alla verifica dell'eventuale lotto interessato all'acquisto. - As far as values relating to the matt finish of the product and to tests carried out by certified external laboratories whose results are available upon request at Headoffice, we are willing to check the lot you are interested in purchasing. - Valeurs se référant à la finition naturelle du produit selon des tests effectués par des laboratoires extérieurs accrédités et à la disposition de toute personne intéressée auprès de nos bureaux; nous sommes disponibles pour le contrôle de l'éventuel lot concerné par l'achat. - Werte bezogen auf das natürliche Produktfinish und in anerkannten externen Labors geprüft, im Unternehmen erhältlich; für eventuelle Prüfungen der zu erwerbenden Warenposten stehen wir gern zur Verfügung. Значения, касающиеся натуральных характеристик изделий и тестов, выполненных внешними авторизованными лабораториями, имеются компании. Мы готовы выполнить проверку партии товара, которую намереваетесь приобрести.

*** Dato riferito al formato 60x60 cm. - Detail referred to the 60x60 cm size. - Donnée se rapportant au format 60x60 cm. - Auf die Formate 60x60 cm bezogen. - Значения, касающиеся натуральных характеристик изделий и тестов.

• Per prodotti chimici di uso domestico e additivi per piscina. - For domestic chemicals and swimming pool additives. - Pour produits chimiques à usage domestique et additifs pour piscines. - Für chemische Produkte für den Hausgebrauch und Schwimmbadzusätze. - Для бытовых химикатов и добавок для бассейнов.

▲ Valori wet DCOF specifici disponibili in azienda - Wet DCOF specific values available at the company - Valeurs wet DCOF spécifiques disponibles à l'usine - Prüfwerte Wet DCOF stehen im Werk zur Verfügung - Показатели wet DCOF доступны при запросе

Le tonalità dei campioni sono da considerarsi puramente indicative. - Tones of samples are indicative. - Les tonalités des échantillons sont purement indicatives. Die farbtöne der Muster sind als rein indicativ zu betrachten. - Тона образцов ориентировочные.

Life

Living a natural mood



Life è la bellezza di abitare spazi naturalmente. È il piacere di vivere ambienti caldi e accoglienti. È la libertà di godersi ogni istante della vita. Tutti i giorni.

Life enhances the pleasure of natural spaces. It's the joy of living amongst warm and welcoming atmospheres. Day in, day out.

Life c'est la beauté d'habiter des espaces naturellement. C'est le plaisir de vivre des environnements chaleureux et accueillants. C'est la liberté de profiter de tous les instants de la vie. Et cela, chaque jour.

Life ist Schönheit, die aus einem natürlichen Wohnstil entsteht. Es ist die Freude daran, in warmen, behaglichen Räumen zu leben. Und die Freiheit, jeden Augenblick des Lebens zu genießen. Tag für Tag.

Life – это радость жить в натуральных пространствах. Упоение теплой и уютной обстановкой. Свобода наслаждаться каждым мгновением жизни. Каждый день.



Info
Resources
Tools



WOOD LOOK

Floor: WALNUT 20x120 MATT RT, TEXTURED RT R11 C
Wall: WALNUT STAVE 30x120 MATT

Colori - Formati

Colors - Sizes

- 20x120 9 mm MATT RT
- 20x120 9 mm TEXTURED RT R11 C
- 30x120 20 mm AEXTRA20 RT R11 C

OAK



NORDIC



NOCE



WALNUT



9 mm



20x120
7⁷/₈"x47²/₈"

MATT RT

9 mm



20x120
7⁷/₈"x47²/₈"

TEXTURED RT R11 C

20 mm











30x120
11³/₈"x47²/₈"

AEXTRA20 RT R11 C

*La liste a jour des produits et formats des series certifiees QB-UPEC est disponible en usine.

La gamma

The range

| | OAK | NORDIC | NOCE | WALNUT |
|-------------------|--------------------------------------------------------------------------------------------------|------------------------------------------------------------------------------------------|----------------------------------------------------------------------------------------------------|--------------------------------------------------------------------------------------------|
| MATT RT | 20x120  | 20x120  | 20x120  | 20x120  |
| TEXTURED RT R11 C | 20x120  | | 20x120  | |
| AEXTRA20 RT R11 C | 30x120 Doga°  | | 30x120 Doga°  | |

° Doga - Plank size - Lame - Diele - Доска

RT Rettificato, squadrato, monocalibro. - Rectified, squared, one caliber. - Rectifié, mis d'équerre et monocalibre. - Rektifiziert, rechtwinkelig und Ein kaliber. - Ректифицированный, одного калибра.

Decori

Decors

STAVE 30x120 cm . 11¹³/₁₆"x47²/₈" MATT



OAK



NORDIC



NOCE



WALNUT



| | A E X T R A 2 0 | | |
|--------|-------------------------------|----------------------------------|-------------------------------|
| | 20x120 cm 7 1/8" x 47 7/8" | 30x120 cm ° 11 3/8" x 47 7/8" | 6,2x60 cm 2 1/8" x 23 5/8" |
| | MATT RT | TEXTURED RT R11 C | MATT |
| Nordic | ● | | ● |
| Oak | ● | ● | ● |
| Noce | ● | ● | ● |
| Walnut | ● | | ● |

| IMBALLI - PACKAGING - CONDITIONNEMENT - VERPACKUNGS-EINHEITEN - УПАКОВКА | | | | | | | |
|--------------------------------------------------------------------------|------------------------------------------|---|------|--------|---------------------------|-------|----------|
| Formato - Size - Format - Формат | Scatola - Box - Boîte - Karton - Коробка | | | | Pallet - Palette - Палета | | |
| 20x120 | 7 1/8" x 47 7/8" | 6 | 1,44 | ~31,32 | 32 | 46,08 | ~1002,24 |
| 30x120 A E X T R A 2 0 | 11 3/8" x 47 7/8" | 2 | 0,72 | ~33,35 | 36 | 25,92 | ~1200,60 |

RT Rettificato, squadrato, monocalibro. - Rectified, squared, one caliber. - Rectifié, mis d'equerre et monocalibre. - Rektifiziert, rechtwinkling und Ein kaliber. - Ректифицированный, одна калибра.
 ° Doga - Plank size - Lame - Diele - Доска

Si raccomanda l'utilizzo di una fuga di 2/3 mm al fine di semplificare le operazioni di posa e ottimizzare la naturalezza del risultato finale. - We recommend you a 2/3 mm grout joint to simplify the laying and optimize the naturalness of the final result. - Un joint de 2/3 mm est conseillé afin de simplifier les opérations de pose et optimiser l'effet naturel du résultat final. - Es wird empfohlen mit einer Fuge von 2/3 mm zu arbeiten, um am Ende den Verlegevorgang zu vereinfachen und die bestmögliche Natürlichkeit der Arbeit zu erzielen. - Для облегчения операций укладки и повышения натуральности вида конечного результата рекомендуется выполнять шов шириной 2-3 мм.

Al fine di facilitare la manutenzione ordinaria si raccomanda di effettuare un lavaggio acido dopo 48 ore dalla stuccatura con un acido specifico per grès porcellanato. - In order to favour the ordinary maintenance procedures, it is recommended to carry out an acid wash of the surface after 48 hours from grout filling using an acid agent specific for porcelain stoneware tiles. - Afin de faciliter l'entretien ordinaire de votre carrelage, nous vous conseillons de le laver 48 heures après le colmatage des joints, avec un acide spécifique pour grès cérame. - Um die Instandhaltung zu erleichtern, empfiehlt es sich 48 Stunden nach der Stuckatur mit einer sauren Lösung speziell für Feinsteinzeug zu waschen. - Чтобы упростить уход за плиткой, спустя 48 часов после затирки швов рекомендуется выполнить обработку кислотным продуктом, пригодным для керамогранита.

CARATTERISTICHE TECNICHE

TILE PERFORMANCE DATA - NOTES TECHNIQUES - TECHNISCHE AUSKÜNFTE - ТЕХНИЧЕСКАЯ ХАРАКТЕРИСТИКА

Classificazione secondo EN ISO 14411 ISO 13006 annesso G gruppo Bla con Ev ≤0,5% - Classification in accordance with EN ISO 14411 ISO 13006 annex G standards Bla with Ev ≤ 0,5% - Classification selon EN ISO 14411 ISO 13006 annexe G groupe Bla avec Ev ≤0,5% - Klassifizierung gemäß EN ISO 14411 ISO 13006 anlage G Gruppe Bla mit Ev ≤0,5% - Классификация в соответствии с EN ISO 14411 ISO 13006, приложение G, стандарт Bla, где Ev ≤0,5%

| | CARATTERISTICA TECNICA TECHNICAL CHARACTERISTIC CARACTERISTIQUE TECHNIQUE TECHNISCHE DATEN ТЕХНИЧЕСКАЯ ХАРАКТЕРИСТИКА | METODO DI PROVA TESTS METHOD METHODE D'ESSAI TESTMETHODE МЕТОД ИСПЫТАНИЯ | VALORE * MEDIO "CAESAR" AVERAGE "CAESAR" VALUE* VALEUR * MOYEN "CAESAR" "CAESAR" DURCHSCHNITTSWERT* СРЕДНЕЕ ЗНАЧЕНИЕ "CAESAR"* | VALORE * MEDIO "CAESAR" AVERAGE "CAESAR" VALUE A E X T R A 2 0 OPEN YOUR STYLE |
|--|-------------------------------------------------------------------------------------------------------------------------------------------------------------------------------------------------------------------------------------|--------------------------------------------------------------------------------------|--------------------------------------------------------------------------------------------------------------------------------------------|-----------------------------------------------------------------------------------------------------------------------------------------------------------------------------------------------------------------------------------------------------------------------------------------|
| | Dimensione - Size Dimension - Abmessungen - Размер | ISO 10545-2 | Conforme - In accordance Conforme - Erfüllt - Соответствует | Conforme - In accordance Conforme - Erfüllt - Соответствует |
| | Assorbimento d'acqua* - Water absorption* Absorption d'eau* - Wasseraufnahme* - % Поглощения воды* | ISO 10545-3 | ≤ 0,1% | ≤ 0,1% |
| | Resistenza alla flessione* - Bending strength* Résistance à la flexion* - Biegezugfestigkeit* - Упругость* | ISO 10545-4 | Conforme - In accordance Conforme - Erfüllt - Соответствует | Non applicabile a piastrelle con una forza di rottura Not applicable to tiles with a breaking strength N'est pas applicable aux carreaux avec une charge de rupture Nicht anwendbar bei Fliesen mit einer Bruchlast Не применяется в отношении плиток с прочностью на изрыв |
| | Sforzo di rottura (S) - Breaking strength Charge de rupture - Bruchlast - Разрушающее усилие | ISO 10545-4 | Sps ≥ 7,5 mm S ≥ 1300 N | > 10.000 N |
| | Resistenza all'abrasione profonda* - Deep scratch resistance* Résistance à l'abrasion profonde* - Widerstand gegen Tiefenverschleiß* Устойчивость к глубокому истиранию* | ISO 10545-6 | Conforme - In accordance Conforme - Erfüllt - Соответствует | Conforme - In accordance Conforme - Erfüllt - Соответствует |
| | Coefficiente di dilatazione termica lineare* - Thermal linear expansion coefficient* Coefficient de dilatation thermique linéaire* - Koeffizient der linearen thermischen Dehnung* - Коэффициент линейного теплового расширения* | ISO 10545-8 | = 7 (10 ⁻⁶ °C ⁻¹) | = 7 (10 ⁻⁶ °C ⁻¹) |
| | Resistenza agli sbalzi termici* - Thermal shock resistance* Résistance aux écarts de température* - Temperaturwechsel Beständigkeit* Устойчивость к тепловому перепаду* | ISO 10545-9 | Resistente - Resistant Résistante - Beständig - Стойкий | Resistente - Resistant Résistante - Beständig - Стойкий |
| | Dilatazione all'umidità* - Expansion in humidity* Dilatation à l'humidité* - Feuchtigkeitsausdehnung* Расширение в условиях влажности* | ISO 10545-10 | ≤ 0,1 (mm/m) | ≤ 0,1 (mm/m) |
| | Resistenza al gelo* - Frost resistance* Résistance au gel* - Frostbeständigkeit* - Морозостойчивость* | ISO 10545-12 | Resistente - Resistant Résistante - Beständig - Стойкий | Resistente - Resistant Résistante - Beständig - Стойкий |
| | Resistenza all'attacco chimico* - Resistance to chemical attack* Résistance à l'attaque chimique* - Beständigkeit gegen Chemikalien* Устойчивость к химическому воздействию* | ISO 10545-13 | Resistente - Resistant Résistante - Beständig - Стойкий | Resistente - Resistant Résistante - Beständig - Стойкий |
| | Carico statico - Static load Charge statique - Statische Last Статическая нагрузка | EN 12825 | - | 30x120 KN>3,0 |
| | Resistenza alle macchie* - Resistance to stains* Résistance aux taches* - Fleckenbeständigkeit* Устойчивость к образованию пятен* | ISO 10545-14 | Pulibile - Cleanable Nettoyable - Leicht zu reinigen Чистящийся | Centro - Centre - Au centre - Mitte - По центру Centro lato - Side centre - Au centre latéralement Mitte Seite - По центру грани Diagonale - Diagonal - En diagonale Diagonal - По диагонали |
| | Resistenza allo scivolamento** - Slip resistance** Résistance au glissement** - Rutschhemmende Eigenschaft** Сопротивление скольжению** | DIN 51130 - DIN 51097 | R9 Matt | R11 C Textured |
| | Spessore nominale - Nominal Thickness Epaisseur nominal - Nominalstärke Номинальная толщина | ▲ ANSI A326.3 | Wet DCOF ≥ 0,42 | Wet DCOF ≥ 0,55 |
| | | | 9 mm | 20 mm |

* Valori medi riferiti agli ultimi due anni di produzione e relativi alla finitura naturale del prodotto - Average values referred to the last two years of production and related to the matt finish of the product - Valeurs moyennes des deux dernières années de production et relatifs à la finition naturelle du produit - Durchschnittswerte, die sich auf die letzten zwei Produktionsjahre beziehen und auf die matte Oberfläche - Средние значения относятся к последним двум годам производства и натуральной отделке поверхности

** Valori relativi alla finitura naturale del prodotto ed a test effettuati da laboratori esterni accreditati, disponibili in azienda; ci rendiamo disponibili alla verifica dell'eventuale lotto interessato all'acquisto. - As far as values relating to the matt finish of the product and to tests carried out by certified external laboratories whose results are available upon request at Headoffice, we are willing to check the lot you are interested in purchasing. - Valeurs se référant à la finition naturelle du produit selon des tests effectués par des laboratoires extérieurs accrédités et à la disposition de toute personne intéressée auprès de nos bureaux; nous sommes disponibles pour le contrôle de l'éventuel lot concerné par l'achat. - Werte bezogen auf das natürliche Produktfinish und in anerkannten externen Labors geprüft, im Unternehmen erhältlich; für eventuelle Prüfungen der zu erwerbenden Warenposten stehen wir gern zur Verfügung. - Значения, касающиеся натуральных характеристик изделий и тестов, выполненных внешними авторизованными лабораториями, имеются в компании. Мы готовы выполнить проверку партии товара, которую намереваетесь приобрести.

• Per prodotti chimici di uso domestico e additivi per piscina. - For domestic chemicals and swimming pool additives. - Pour produits chimiques à usage domestique et additifs pour piscines. - Für chemische Produkte für den Hausgebrauch und Schwimmbadzusätze. - Для бытовых химикатов и добавок для бассейнов.

▲ Valori wet DCOF specifici disponibili in azienda - Wet DCOF specific values available at the company - Valeurs wet DCOF spécifiques disponibles à l'usine - Prüfwerte Wet DCOF stehen im Werk zur Verfügung - Показатели wet DCOF доступны при запросе

Le tonalità dei campioni sono da considerarsi puramente indicative. - Tones of samples are indicative. - Les tonalités des échantillons sont purement indicatives. - Die Farbtöne der Muster sind als rein indicativ zu betrachten. - Тона образцов ориентировочные.

Meet

Wood just as you like it



Un look legno dal sapore vissuto ed eclettico che incontra i tuoi gusti, ma anche altri materiali e ispirazioni, per dar vita allo stile che desideri.

An antiqued and eclectic wood look that matches your taste, but also other materials and inspirations, to give rise to the style you desire.

Un aspect bois effet patiné et éclectique qui répond à vos goûts, mais également d'autres matériaux et inspirations, pour donner vie au style que vous souhaitez.

Eine eklektische Shabby Chic-Holzoptik, die ganz zu Ihrem Geschmack passt. Und auch zu anderen Materialien und Inspirationsquellen, um genau den Stil zu schaffen, den Sie wünschen.

Плитка с эклектичным эффектом старинного дерева и другие материалы позволяют воплотить в жизнь ваш неповторимый стиль, полностью соответствующий вашим вкусовым предпочтениям.



Info
Resources
Tools



Floor: CHIC BEIGE 20x120 MATT RT
Wall: ECLECTIC BROWN STAVE 30x120 MATT
Furniture by CLOS: TC.MINT MATT

Meet

WOOD LOOK

Colori - Formati

Colors - Sizes

20x120 9 mm MATT RT
 20x120 CHEVRON 9 mm MATT RET
 20x120 9 mm GRIP RT R11 C
 30x120 . 80x80 . 60x60 20 mm AEXTRA20 RT R11 C

SCANDI WHITE



CHIC BEIGE



ALLURE HAZEL



ECLECTIC BROWN



9 mm



20x120
7⁷/₈"x47⁵/₈"

MATT RT

MATT RET

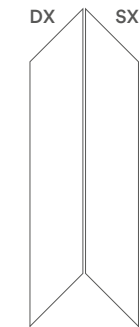

20x120 CHEVRON
7⁷/₈"x47⁵/₈"

9 mm



20x120
7⁷/₈"x47⁵/₈"

GRIP RT R11 C

20 mm



30x120
11⁵/₈"x47⁵/₈"

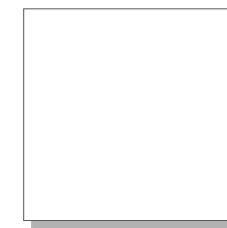

80x80
31¹/₈"x31¹/₈"

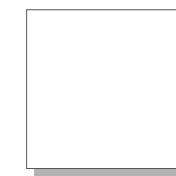

60x60
23⁵/₈"x23⁵/₈"

AEXTRA20 RT R11 C

Meet

La gamma

The range

SCANDI WHITE

CHIC BEIGE

ALLURE HAZEL



ECLECTIC BROWN



MATT RT
MATT RET*

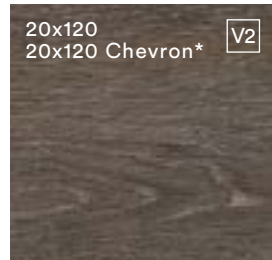
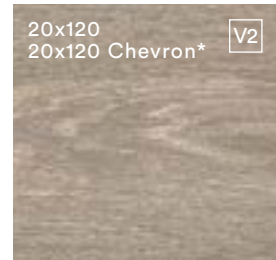
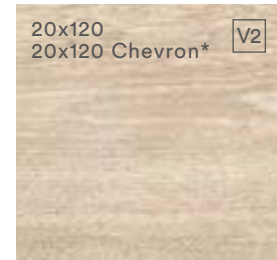
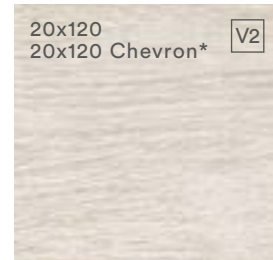

GRIP RT R11 C

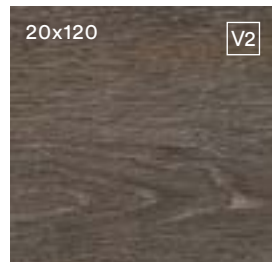
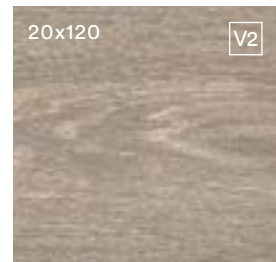
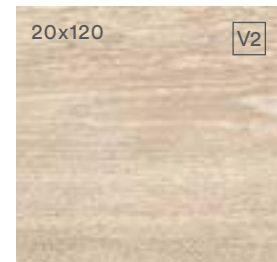
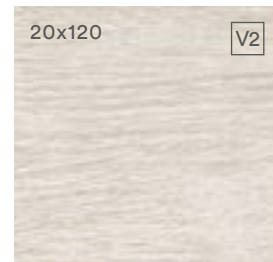

AEXTRA20 RT R11 C

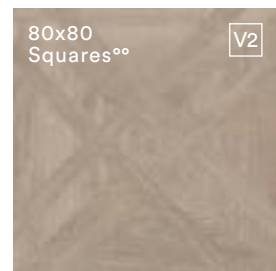
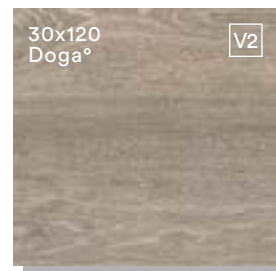
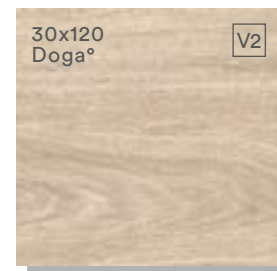

* Doga - Plank size - Lame - Diele - Доска

°° Listellato/Squares - Listel size/Squares - Multifrise/Squares - Leistenoptik/Squares - Эффект соединенных планок/Squares

Nei formati 80x80 e 60x60 l'estetica dei prodotti richiama doghe accostate tra loro o un look a cassettoni, mentre nel formato 30x120 viene riprodotta soltanto la texture del legno. - In the 80x80 and 60x60 sizes, the styling of the products recalls planks placed side-by-side or a coffered look, while the 30x120 size reproduces the texture of wood alone. - Dans les formats 80x80 et 60x60 l'esthétique des produits rappelle des listels ou un aspect à caissons alors que le format 30x120 reproduit uniquement la texture du bois. - In den Formaten 80x80 und 60x60 Verweist die Optik der Produkte auf Aneinandergelagte Dielen Oder auf Ein Kassettenmotiv, während im Format 30x120 nur die Struktur des Holzes wiedergegeben wird. - В форматах 80x80 и 60x60 эстетика плитки напоминает размещенные рядом доски или кесонный потолок, в то время как в формате 30x120 воспроизводится только текстура дерева.

RT Rettificato, quadrato, monocalibro. - Rectified, squared, one caliber. - Rectifié, mis d'équerre et monocalibre. - Rektifiziert, rechtwinkelig und Ein kaliber. - Ректифицированный, одного калибра.
RET Rettificato. - Rectified. - Rectifié. - Rektifiziert. - Ректифицированный.

Decori

Decors

TARSIA 20x20 cm . 7⁷/₈"x7⁷/₈" MATT RT

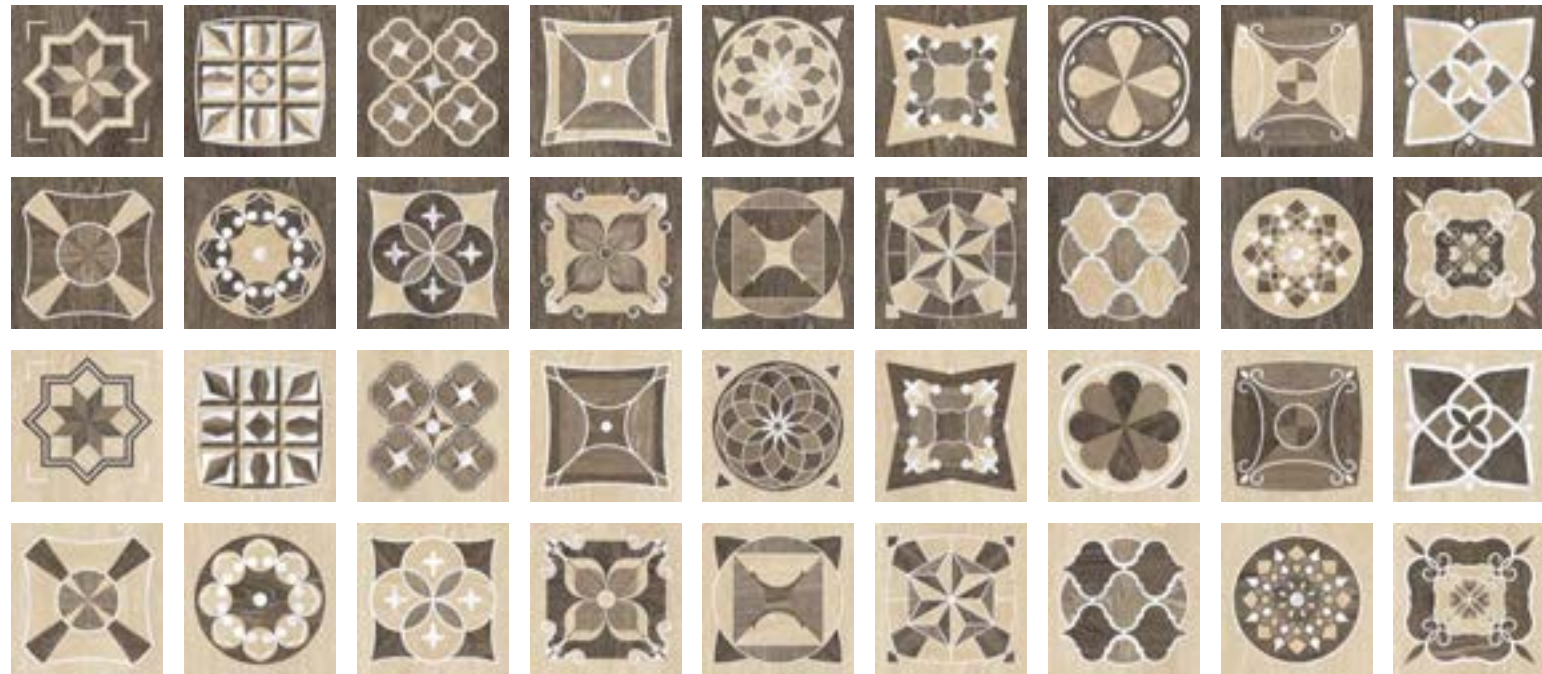

SQUARES 80x80 cm . 31⁴/₈"x31⁴/₈" MATT RT



CHIC BEIGE



ALLURE HAZEL

STAVE 30x120 cm . 11¹³/₁₆"x47²/₈" MATT



SCANDI WHITE



CHIC BEIGE



ALLURE HAZEL



ECLECTIC BROWN



| | A E X T R A 2 0 | | A E X T R A 2 0 | | A E X T R A 2 0 | | |
|----------------|--------------------------------------|----------------------------------------------|-------------------------------------------|-----------------------------------------|-----------------------------------------|------------------------------|------------------------------------------------------|
| | 20x120 cm 7 1/8" x 4 7/8" 9 mm | 20x120 cm Chevron 7 1/8" x 4 7/8" 9 mm | 30x120 cm ° 11 5/16" x 4 7/8" 20 mm | 80x80 cm °° 3 1/8" x 3 1/8" 20 mm | 60x60 cm °° 2 3/8" x 2 3/8" 20 mm | 6,2x60 cm 2 1/8" x 2 3/8" | Battiscopa - Bullnose Plinthe - Sockel Плинтус |
| | MATT RT | GRIP RT R11 C | MATT RET | RT R11 C | RT R11 C | MATT | |
| Scandi White | ● | ● | ● | | | ● | |
| Chic Beige | ● | ● | ● | | | ● | |
| Allure Hazel | ● | ● | ● | ● | | ● | |
| Eclectic Brown | ● | ● | ● | | | ● | |

| IMBALLI - PACKAGING - CONDITIONNEMENT - VERPACKUNGS-EINHEITEN - УПАКОВКА | | | | | | | |
|--------------------------------------------------------------------------|-------------------|------------------------------------------|------|--------|---------------------------|-------|----------|
| Formato - Size - Format - Формат | | Scatola - Box - Boîte - Karton - Коробка | | | Pallet - Palette - Палета | | |
| CM | INCHES | PZ | MQ | KG | SC | MQ | KG |
| 20x120 | 7 1/8" x 4 7/8" | 6 | 1,44 | ~31,10 | 32 | 46,08 | ~995,20 |
| 20x120 Chevron | 7 1/8" x 4 7/8" | 4 | 0,80 | ~17,20 | 40 | 32,00 | ~688,00 |
| 30x120 A E X T R A 2 0 | 11 5/16" x 4 7/8" | 2 | 0,72 | ~33,35 | 36 | 25,92 | ~1200,60 |
| 60x60 A E X T R A 2 0 | 2 3/8" x 2 3/8" | 2 | 0,72 | ~32,00 | 30 | 21,60 | ~960,00 |
| 80x80 A E X T R A 2 0 | 3 1/8" x 3 1/8" | 1 | 0,64 | ~29,70 | 42 | 26,88 | ~1247,40 |
| Squares 80x80 | 3 1/8" x 3 1/8" | 2 | 1,28 | ~27,36 | 48 | 61,44 | ~1313,28 |
| Stave 30x120 | 11 5/16" x 4 7/8" | 1 | 0,36 | ~8,43 | - | - | - |
| Tarsia 20x20 | 7 1/8" x 7 1/8" | 16 | 0,64 | ~12,62 | - | - | - |

20x120 Chevron è incastolato a 4 pezzi per scatola, suddivisi tra 2 destri e 2 sinistri. - 20x120 Chevron is packed in boxes containing 4 pieces each, 2 left and 2 right. - Les carreaux 20x120 Chevron sont conditionnés 4 par 4, 2 droits et 2 gauches. - 20x120 Chevron ist in Kartons mit jeweils 4 Fliesen, 2 rechten und 2 linken, verpackt. - 20x120 Chevron упаковывается по 4 штуки на коробку, 2 правые и 2 левые.

RT Rettificato, quadrato, monocalibro. - Rectified, squared, one caliber. - Rectifié, mis d'équerre et monocalibre. - Rektifiziert, rechtwinkelig und Ein kaliber. - Ректифицированный, одного калибра.

RET Rettificato. - Rectified. - Rectifié. - Rektifiziert. - Ректифицированный.

° Doga - Plank size - Lame - Diele - Доска

°° Listellato/Squares - Listel size/Squares - Multifrise/Squares - Leistenoptik/Squares - Эффект соединенных планок/Squares

Si raccomanda l'utilizzo di una fuga di 2/3 mm al fine di semplificare le operazioni di posa e ottimizzare la naturalezza del risultato finale. - We recommend you a 2/3 mm grout joint to simplify the laying and optimize the naturalness of the final result. - Un joint de 2/3 mm est conseillé afin de simplifier les opérations de pose et optimiser l'effet naturel du résultat final. - Es wird empfohlen mit einer Fuge von 2/3 mm zu arbeiten, um am Ende den Verlegevorgang zu vereinfachen und die bestmögliche Natürlichkeit der Arbeit zu erzielen. - Для облегчения операций укладки и повышения натуральности вида конечного результата рекомендуется выполнять шов шириной 2-3 мм.

Al fine di facilitare la manutenzione ordinaria si raccomanda di effettuare un lavaggio acido dopo 48 ore dalla stuccatura con un acido specifico per grès porcellanato. - In order to favour the ordinary maintenance procedures, it is recommended to carry out an acid wash of the surface after 48 hours from grout filling using an acid agent specific for porcelain stoneware tiles. - Afin de faciliter l'entretien ordinaire de votre carrelage, nous vous conseillons de le laver 48 heures après le colmatage des joints, avec un acide spécifique pour grès cérame. - Um die Instandhaltung zu erleichtern, empfiehlt es sich 48 Stunden nach der Stuckatur mit einer sauren Lösung speziell für Feinsteinzeug zu waschen. - Чтобы упростить уход за плиткой, спустя 48 часов после затирки швов рекомендуется выполнить обработку кислотным продуктом, пригодным для керамогранита.

CARATTERISTICHE TECNICHE

TILE PERFORMANCE DATA - NOTES TECHNIQUES - TECHNISCHE AUSKÜNFTE - ТЕХНИЧЕСКАЯ ХАРАКТЕРИСТИКА

Classificazione secondo EN ISO 14411 ISO 13006 annesso G gruppo Bla con Ev ≤0,5% - Classification in accordance with EN ISO 14411 ISO 13006 annex G standards Bla with Ev ≤ 0,5% - Classification selon EN ISO 14411 ISO 13006 annexe G groupe Bla avec Ev ≤0,5% - Klassifizierung gemäß EN ISO 14411 ISO 13006 anlage G Gruppe Bla mit Ev ≤0,5% - Классификация в соответствии с EN ISO 14411 ISO 13006, приложение G, стандарт Bla, где Ev ≤0,5%

| | CARATTERISTICA TECNICA TECHNICAL CHARACTERISTIC CARACTERISTIQUE TECHNIQUE TECHNISCHE DATEN ТЕХНИЧЕСКАЯ ХАРАКТЕРИСТИКА | METODO DI PROVA TESTS METHOD METHODE D'ESSAI TESTMETHODE МЕТОД ИСПЫТАНИЯ | VALORE * MEDIO "CAESAR" AVERAGE "CAESAR" VALUE * VALEUR * MOYEN "CAESAR" "CAESAR" DURCHSCHNITTSWERT * СРЕДНЕЕ ЗНАЧЕНИЕ "CAESAR" * | VALORE * MEDIO "CAESAR" AVERAGE "CAESAR" VALUE A E X T R A 2 0 OPEN YOUR STYLE |
|--|-------------------------------------------------------------------------------------------------------------------------------------------------------------------------------------------------------------------------------------|--------------------------------------------------------------------------------------|-----------------------------------------------------------------------------------------------------------------------------------------------|-----------------------------------------------------------------------------------------------------------------------------------------------------------------------------------------------------------------------------------------------------------------------------------------------------------------------------|
| | Dimensione - Size Dimension - Abmessungen - Размер | ISO 10545-2 | Conforme - In accordance Conforme - Erfüllt - Соответствует | Conforme - In accordance Conforme - Erfüllt - Соответствует |
| | Assorbimento d'acqua* - Water absorption* Absorption d'eau* - Wasseraufnahme* - % Поглощения воды* | ISO 10545-3 | ≤ 0,1% | ≤ 0,1% |
| | Resistenza alla flessione* - Bending strength* Résistance à la flexion* - Biegezugfestigkeit* - Упругость* | ISO 10545-4 | Conforme - In accordance Conforme - Erfüllt - Соответствует | Non applicabile a piastrelle con una forza di rottura Not applicable to tiles with a breaking strength N'est pas applicable aux carreaux avec une charge de rupture Nicht anwendbar bei Fliesen mit einer Bruchlast Не применяется в отношении плиток с прочностью на изрыв ≥ 3000 N ≥ 3000 N ≥ 3000 N |
| | Sforzo di rottura (S) - Breaking strength Charge de rupture - Bruchlast - Разрушающее усилие | ISO 10545-4 | Sps ≥ 7,5 mm S ≥ 1300 N | > 10.000 N |
| | Resistenza all'abrasione profonda* - Deep scratch resistance* Résistance à l'abrasion profonde* - Widerstand gegen Tiefenverschleiß* Устойчивость глубокому истиранию* | ISO 10545-6 | Conforme - In accordance Conforme - Erfüllt - Соответствует | Conforme - In accordance Conforme - Erfüllt - Соответствует |
| | Coefficiente di dilatazione termica lineare* - Thermal linear expansion coefficient* Coefficient de dilatation thermique linéaire* - Koeffizient der linearen thermischen Dehnung* - Коэффициент линейного теплового расширения* | ISO 10545-8 | = 7 (10 ⁻⁶ °C ⁻¹) | = 7 (10 ⁻⁶ °C ⁻¹) |
| | Resistenza agli sbalzi termici* - Thermal shock resistance* Résistance aux écarts de température* - Temperaturwechsel Beständigkeit* Устойчивость к тепловому перепаду* | ISO 10545-9 | Resistente - Resistant Résistante - Beständig - Стойкий | Resistente - Resistant Résistante - Beständig - Стойкий |
| | Dilatazione all'umidità* - Expansion in humidity* Dilatation à l'humidité* - Feuchtigkeitsausdehnung* Расширение в условиях влажности* | ISO 10545-10 | ≤ 0,1 (mm/m) | ≤ 0,1 (mm/m) |
| | Resistenza al gelo* - Frost resistance* Résistance au gel* - Frostbeständigkeit* - Морозостойчивость* | ISO 10545-12 | Resistente - Resistant Résistante - Beständig - Стойкий | Resistente - Resistant Résistante - Beständig - Стойкий |
| | Resistenza all'attacco chimico • - Resistance to chemical attack • Résistance à l'attaque chimique • - Beständigkeit gegen Chemikalien • Устойчивость к химическому воздействию • | ISO 10545-13 | Resistente - Resistant Résistante - Beständig - Стойкий | Resistente - Resistant Résistante - Beständig - Стойкий |
| | Carico statico - Static load Charge statique - Statische Last Статическая нагрузка | EN 12825 | - | Centro - Centre - Au centre Mitte - По центру Centro lato - Side centre - Au centre latéralement - Mitte Seite - По центру grani Diagonale - Diagonal - En diagonale Diagonal - По диагонали |
| | Classe di carico di rottura*** - Breaking load class*** Classe de charge de rupture*** - Bruchlastklasse*** Класс стойкости к разрушающей нагрузке*** | EN 1339 | - | U11 T11 |
| | Resistenza alle macchie* - Resistance to stains* Résistance aux taches* - Fleckenbeständigkeit* Устойчивость к образованию пятен* | ISO 10545-14 | Pulibile - Cleanable Nettoyable - Leicht zu reinigen Чистящийся | Pulibile - Cleanable Nettoyable - Leicht zu reinigen Чистящийся |
| | Resistenza allo scivolamento** - Slip resistance** Résistance au glissement** - Rutschhemmende Eigenschaft** Сопrotivление скольжению** | DIN 51130 - DIN 51097 | R9 Matt | R11 C Grip |
| | Spessore nominale - Nominal Thickness Épaisseur nominal - Nominalstärke Номинальная толщина | ▲ ANSI A326.3 | Wet DCOF ≥ 0,42 | Wet DCOF ≥ 0,55 |
| | | | 9 mm | 20 mm |

* Valori medi riferiti agli ultimi due anni di produzione e relativi alla finitura naturale del prodotto - Average values referred to the last two years of production and related to the matt finish of the product - Valeurs moyennes des deux dernières années de production et relatifs à la finition naturelle du produit - Durchschnittswerte, die sich auf die letzten zwei Produktionsjahre beziehen und auf die matte Obaerfläche - Средние значения относятся к последним двум годам производства и натуральной отделке поверхности

** Valori relativi alla finitura naturale del prodotto ed a test effettuati da laboratori esterni accreditati, disponibili in azienda; ci rendiamo disponibili alla verifica dell'eventuale lotto interessato all'acquisto. - As far as values relating to the matt finish of the product and to tests carried out by certified external laboratories whose results are available upon request at Headoffice, we are willing to check the lot you are interested in purchasing. - Valeurs se référant à la finition naturelle du produit selon des tests effectués par des laboratoires extérieurs accrédités et à la disposition de toute personne intéressée auprès de nos bureaux; nous sommes disponibles pour le contrôle de l'éventuel lot concerné par l'achat. - Werte bezogen auf das natürliche Produktfinish und in anerkannten externen Labors geprüft, im Unternehmen erhältlich; für eventuelle Prüfungen der zu erwerbenden Warenposten stehen wir gern zur Verfügung. - Значения, касающиеся натуральных характеристик изделий и тестов, выполненных внешними авторизованными лабораториями, имеются компании. Мы готовы выполнить проверку партии товара, которую намереваетесь приобрести.

*** Dato riferito al formato 60x60 cm. - Detail referred to the 60x60 cm size. - Donnée se rapportant au format 60x60 cm. - Auf die Formate 60x60 cm bezogen. - Значения, касающиеся натуральных характеристик изделий и тестов.

• Per prodotti chimici di uso domestico e additivi per piscina. - For domestic chemicals and swimming pool additives. - Pour produits chimiques à usage domestique et additifs pour piscines. - Für chemische Produkte für den Hausgebrauch und Schwimmbadzusätze. - Для бытовых химикатов и добавок для бассейнов.

▲ Valori wet DCOF specifici disponibili in azienda - Wet DCOF specific values available at the company - Valeurs wet DCOF spécifiques disponibles à l'usine - Prüfwerte Wet DCOF stehen im Werk zur Verfügung - Показатели wet DCOF доступны при запросе

Le tonalità dei campioni sono da considerarsi puramente indicative. - Tones of samples are indicative. - Les tonalités des échantillons sont purement indicatives. - Die farböne der Muster sind als rein indicativ zu betrachten. - Тона образцов ориентировочные.

Vibe

Floor & wall dress



Materia viva e vissuta, riverbero della nostra personalità. Pronta ad attenderci, ogni giorno, dove finisce tutto il resto e ricomincia la nostra casa.

Vibe is a material that's a lively reflection of our character. Where everything else ends, our home starts, ready to embrace us each day.

Matière vivante et chargée d'histoire, elle est le reflet de notre personnalité, elle nous accompagne au quotidien au fil du temps et lorsque l'œuvre est terminée, elle redonne vie à l'habitat.

Lebendige und erlebte materie, die unsere Persönlichkeit reflektiert. Und tag für tag dort auf uns wartet, wo der rest der welt endet und unser zuhause beginnt.

Живая материя, отражающая нашу суть и ждущая нас день за днем там, где кончается все остальное и начинается наш дом.



Info
Resources
Tools



WOOD LOOK

Floor: CINDER 20x120 MATT RT

Colori - Formati

Colors - Sizes

20x120 9 mm MATT RT
30x120 . 60x60 20 mm AEXTRA20 RT R11 C

ROVERE



CINDER



9 mm



20x120
7⁷/₈"x47²/₈"

MATT RT

20 mm



30x120
11¹³/₁₆"x47²/₈"



60x60
23⁵/₈"x23⁵/₈"

AEXTRA20 RT R11 C

La gamma

The range

ROVERE

CINDER



MATT RT



20x120

V3

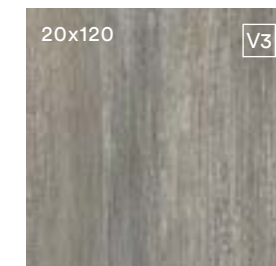

20x120

V3

AEXTRA20 RT R11 C

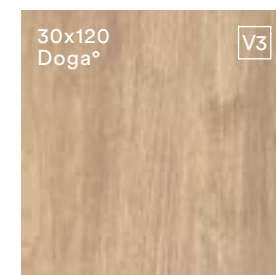

30x120
Doga°

V3

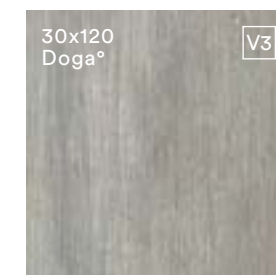

30x120
Doga°

V3

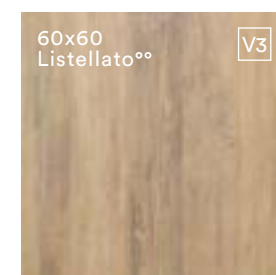

60x60
Listellato°°

V3



60x60
Listellato°°

V3

° Doga - Plank size - Lame - Diele - Доска

°° Listellato - Listel size - Multifrise - Leistenoptik - Эффект соединенных планок

Nei formati 80x80 e 60x60 l'estetica dei prodotti richiama doghe accostate tra loro o un look a cassettoni, mentre nel formato 30x120 viene riprodotta soltanto la texture del legno. - In the 80x80 and 60x60 sizes, the styling of the products recalls planks placed side-by-side or a coffered look, while the 30x120 size reproduces the texture of wood alone. - Dans les formats 80x80 et 60x60 l'esthétique des produits rappelle des listels ou un aspect à caissons alors que le format 30x120 reproduit uniquement la texture du bois. - In den Formaten 80x80 und 60x60 Verweist die Optik der Produkte auf Aneinandergelegte Dielen Oder auf Ein Kassettenmotiv, während im Format 30x120 nur die Struktur des Holzes wiedergegeben wird. - В форматах 80x80 и 60x60 эстетика плитки напоминает размещенные рядом доски или кассонный потолок, в то время как в формате 30x120 воспроизводится только текстура дерева.

RT Rettificato, squadrato, monocalibro. - Rectified, squared, one caliber. Rectifié, mis d'équerre et monocalibre. - Rektifiziert, rechtwinkelig und Ein kaliber. Ректифицированный, одного калибра.

*La liste a jour des produits et formats des series certifiées QB-UPEC est disponible en usine.



| | A E X T R A 2 0 | | A E X T R A 2 0 | | |
|--------|-----------------------------------------------------------------------------------------------------------|----------------------------------------------------------------------------------------------------------------|----------------------------------------------------------------------------------------------------------------|-----------------------------------------------------------------------------------------------|--|
| | <p>20x120 cm 7¹/₈"x47¹/₈" 9 mm MATT RT</p> | <p>30x120 cm ° 11¹/₈"x47¹/₈" 20 mm RT R11 C</p> | <p>60x60 cm °° 23⁵/₈"x23⁵/₈" 20 mm RT R11 C</p> | <p>6,2x60 cm 2¹/₈"x23⁵/₈" MATT</p> | |
| Rovere | ● | ● | ● | ● | |
| Cinder | ● | ● | ● | ● | |

IMBALLI - PACKAGING - CONDITIONNEMENT - VERPACKUNGS-EINHEITEN - УПАКОВКА

| Formato - Size - Format - Формат | Scatola - Box - Boîte - Karton - Коробка | | Pallet - Palette - Палета | | | | |
|----------------------------------|-------------------------------------------------------------------|---|---------------------------|--------|----|-------|----------|
| 20x120 | 7 ¹ / ₈ "x47 ¹ / ₈ " | 6 | 1,44 | ~31,10 | 32 | 46,08 | ~995,20 |
| 60x60 A E X T R A 2 0 | 23 ⁵ / ₈ "x23 ⁵ / ₈ " | 2 | 0,72 | ~31,66 | 30 | 21,60 | ~949,80 |
| 30x120 A E X T R A 2 0 | 11 ¹ / ₈ "x47 ¹ / ₈ " | 2 | 0,72 | ~33,35 | 36 | 25,92 | ~1200,60 |

RT Rettificato, squadrato, monocalibro. - Rectified, squared, one caliber. - Rectifié, mis d'équerre et monocalibre. - Rektifiziert, rechteckig und Ein kaliber. - Ректифицированный, одного калибра.

- ° Doga - Plank size - Lame - Diele - Доска
- °° Listellato - Listel size - Multifrise - Leistenoptik - Эффект соединенных планок

Si raccomanda l'utilizzo di una fuga di 2/3 mm al fine di semplificare le operazioni di posa e ottimizzare la naturalezza del risultato finale. - We recommend you a 2/3 mm grout joint to simplify the laying and optimize the naturalness of the final result. - Un joint de 2/3 mm est conseillé afin de simplifier les opérations de pose et optimiser l'effet naturel du résultat final. - Es wird empfohlen mit einer Fuge von 2/3 mm zu arbeiten, um am Ende den Verlegevorgang zu vereinfachen und die bestmögliche Natürlichkeit der Arbeit zu erzielen. - Для облегчения операций укладки и повышения натуральности вида конечного результата рекомендуется выполнять шов шириной 2-3 мм.

Al fine di facilitare la manutenzione ordinaria si raccomanda di effettuare un lavaggio acido dopo 48 ore dalla stuccatura con un acido specifico per grès porcellanato. - In order to favour the ordinary maintenance procedures, it is recommended to carry out an acid wash of the surface after 48 hours from grout filling using an acid agent specific for porcelain stoneware tiles. - Afin de faciliter l'entretien ordinaire de votre carrelage, nous vous conseillons de le laver 48 heures après le colmatage des joints, avec un acide spécifique pour grès cérame. - Um die Instandhaltung zu erleichtern, empfiehlt es sich 48 Stunden nach der Stuckatur mit einer sauren Lösung speziell für Feinsteinzeug zu waschen. - Чтобы упростить уход за плиткой, спустя 48 часов после затирки швов рекомендуется выполнить обработку кислотным продуктом, пригодным для керамогранита.

CARATTERISTICHE TECNICHE

TILE PERFORMANCE DATA - NOTES TECHNIQUES - TECHNISCHE AUSKÜNFTE - ТЕХНИЧЕСКАЯ ХАРАКТЕРИСТИКА

Classificazione secondo EN ISO 14411 ISO 13006 annesso G gruppo Bla con Ev ≤0,5% - Classification in accordance with EN ISO 14411 ISO 13006 annex G standards Bla with Ev ≤ 0,5% - Classification selon EN ISO 14411 ISO 13006 annexe G groupe Bla avec Ev ≤0,5% - Klassifizierung gemäß EN ISO 14411 ISO 13006 anlage G Gruppe Bla mit Ev ≤0,5% - Классификация в соответствии с EN ISO 14411 ISO 13006, приложение G, стандарт Bla, где Ev ≤0,5%

| | CARATTERISTICA TECNICA TECHNICAL CHARACTERISTIC CARACTERISTIQUE TECHNIQUE TECHNISCHE DATEN ТЕХНИЧЕСКАЯ ХАРАКТЕРИСТИКА | METODO DI PROVA TESTS METHOD METHODE D'ESSAI TESTMETHODE МЕТОД ИСПЫТАНИЯ | VALORE * MEDIO "CAESAR" AVERAGE "CAESAR" VALUE* VALEUR * MOYEN "CAESAR" "CAESAR" DURCHSCHNITTSWERT* СРЕДНЕЕ ЗНАЧЕНИЕ "CAESAR"* | VALORE * MEDIO "CAESAR" AVERAGE "CAESAR" VALUE A E X T R A 2 0 OPEN YOUR STYLE |
|--|--------------------------------------------------------------------------------------------------------------------------------------------------------------------------------------------------------------------------------------------|--------------------------------------------------------------------------------------|--------------------------------------------------------------------------------------------------------------------------------------------|---------------------------------------------------------------------------------------------------------------------------------------------------------------------------------------------------------------------------------------------------------------------------------------------------------------------------------------------|
| | Dimensione - Size Dimension - Abmessungen - Размер | ISO 10545-2 | Conforme - In accordance Conforme - Erfüllt - Соответствует | Conforme - In accordance Conforme - Erfüllt - Соответствует |
| | Assorbimento d'acqua* - Water absorption* Absorption d'eau* - Wasseraufnahme* - % Поглощения воды* | ISO 10545-3 | ≤ 0,1% | ≤ 0,1% |
| | Resistenza alla flessione* - Bending strength* Résistance à la flexion* - Biegezugfestigkeit* - Упругость* | ISO 10545-4 | Conforme - In accordance Conforme - Erfüllt - Соответствует | Non applicabile a piastrelle con una forza di rottura ≥ 3000 N Not applicable to tiles with a breaking strength ≥ 3000 N N'est pas applicable aux carreaux avec une charge de rupture ≥ 3000 N Nicht anwendbar bei Fliesen mit einer Bruchlast ≥ 3000 N Не применяется в отношении плиток с прочностью на изрыв ≥ 3000 N |
| | Sforzo di rottura (S) - Breaking strength Charge de rupture - Bruchlast - Разрушающее усилие | ISO 10545-4 | Sps ≥ 7,5 mm S ≥ 1300 N | > 10.000 N |
| | Resistenza all'abrasione profonda* - Deep scratch resistance* Résistance à l'abrasion profonde* - Widerstand gegen Tiefenverschleiß* Устойчивость к глубокому истиранию* | ISO 10545-6 | Conforme - In accordance Conforme - Erfüllt - Соответствует | Conforme - In accordance Conforme - Erfüllt - Соответствует |
| | Coefficiente di dilatazione termica lineare* - Thermal linear expansion coefficient* Coefficient de dilatation thermique linéaire* - Koeffizient der linearen thermischen Dehnung* - Коэффициент линейного теплового расширения* | ISO 10545-8 | = 7 (10 ⁻⁶ °C ⁻¹) | = 7 (10 ⁻⁶ °C ⁻¹) |
| | Resistenza agli sbalzi termici* - Thermal shock resistance* Résistance aux écarts de température* - Temperaturwechsel Beständigkeit* Устойчивость к тепловому перепаду* | ISO 10545-9 | Resistente - Resistant Résistante - Beständig - Стойкий | Resistente - Resistant Résistante - Beständig - Стойкий |
| | Dilatazione all'umidità* - Expansion in humidity* Dilatation à l'humidité* - Feuchtigkeitsausdehnung* Расширение в условиях влажности* | ISO 10545-10 | ≤ 0,1 (mm/m) | ≤ 0,1 (mm/m) |
| | Resistenza al gelo* - Frost resistance* Résistance au gel* - Frostbeständigkeit* - Морозостойчивость* | ISO 10545-12 | Resistente - Resistant Résistante - Beständig - Стойкий | Resistente - Resistant Résistante - Beständig - Стойкий |
| | Resistenza all'attacco chimico • - Resistance to chemical attack • Résistance à l'attaque chimique • - Beständigkeit gegen Chemikalien • Устойчивость к химическому воздействию • | ISO 10545-13 | Resistente - Resistant Résistante - Beständig - Стойкий | Resistente - Resistant Résistante - Beständig - Стойкий |
| | Carico statico - Static load Charge statique - Statische Last Статическая нагрузка | EN 12825 | - | 60x60 KN>7,0 30x120 KN>3,0 |
| | Classe di carico di rottura*** - Breaking load class*** Classe de charge de rupture*** - Bruchlastklasse*** Класс стойкости к разрушающей нагрузке*** | EN 1339 | - | Centro - Centre - Au centre - Mitte - По центру KN>5,0 Centro lato - Side centre - Au centre latéralement Mitte Seite - По центру грани KN>5,0 Diagonale - Diagonal - En diagonale Diagonal - По диагонали KN>8,0 KN>6,5 |
| | Resistenza alle macchie* - Resistance to stains* Résistance aux taches* - Fleckenbeständigkeit* Устойчивость к образованию пятен* | ISO 10545-14 | Pulibile - Cleanable Nettoyable - Leicht zu reinigen Чистящийся | U11 T11 Pulibile - Cleanable Nettoyable - Leicht zu reinigen Чистящийся |
| | Resistenza allo scivolamento** - Slip resistance** Résistance au glissement** - Rutschhemmende Eigenschaft** Сопротивление скольжению** | DIN 51130 - DIN 51097 ▲ ANSI A326.3 | R9 Matt Wet DCOF ≥ 0,42 | R11 C Wet DCOF ≥ 0,55 |
| | Spessore nominale - Nominal Thickness Épaisseur nominal - Nominalstärke Номинальная толщина | | 9 mm | 20 mm |

* Valori medi riferiti agli ultimi due anni di produzione e relativi alla finitura naturale del prodotto - Average values referred to the last two years of production and related to the matt finish of the product - Valeurs moyennes des deux dernières années de production et relatifs à la finition naturelle du produit - Durchschnittswerte, die sich auf die letzten zwei Produktionsjahre beziehen und auf die matte Oberfläche - Средние значения относятся к последним двум годам производства и натуральной отделке поверхности

** Valori relativi alla finitura naturale del prodotto ed a test effettuati da laboratori esterni accreditati, disponibili in azienda; ci rendiamo disponibili alla verifica dell'eventuale lotto interessato all'acquisto. - As far as values relating to the matt finish of the product and to tests carried out by certified external laboratories whose results are available upon request at Headoffice, we are willing to check the lot you are interested in purchasing. - Valeurs se référant à la finition naturelle du produit selon des tests effectués par des laboratoires extérieurs accrédités et à la disposition de toute personne intéressée auprès de nos bureaux; nous sommes disponibles pour le contrôle de l'éventuel lot concerné par l'achat. - Werte bezogen auf das natürliche Produktfinish und in anerkannten externen Labors geprüft, im Unternehmen erhältlich; für eventuelle Prüfungen der zu erwerbenden Warenposten stehen wir gern zur Verfügung. - Значения, касающиеся натуральных характеристик изделий и тестов, выполненных внешними авторизованными лабораториями, имеются в компании. Мы готовы выполнить проверку партии товара, которую намереваетесь приобрести.

*** Dato riferito al formato 60x60 cm. - Detail referred to the 60x60 cm size. - Donnée se rapportant au format 60x60 cm. - Auf die Formate 60x60 cm bezogen. - Значения, касающиеся натуральных характеристик изделий и тестов.

• Per prodotti chimici di uso domestico e additivi per piscina. - For domestic chemicals and swimming pool additives. - Pour produits chimiques à usage domestique et additifs pour piscines. - Für chemische Produkte für den Hausgebrauch und Schwimmbadzusätze. - Для бытовых химикатов и добавок для бассейнов.

▲ Valori wet DCOF specifici disponibili in azienda - Wet DCOF specific values available at the company - Valeurs wet DCOF spécifiques disponibles à l'usine - Prüfwerte Wet DCOF stehen im Werk zur Verfügung - Показатели wet DCOF доступны при запросе

Le tonalità dei campioni sono da considerarsi puramente indicative. - Tones of samples are indicative. - Les tonalités des échantillons sont purement indicatives. Die farbtöne der Muster sind als rein indicativ zu betrachten. - Тона образцов ориентировочные.

Stone Look

Dalle pietre più ricercate e apprezzate in natura, una gamma di collezioni in grès porcellanato ideali per infondere carattere e personalità alle tue idee di design.

From the most sophisticated and popular natural stones, a range of porcelain tile collections that is ideal to inject character and personality into your design ideas.

Issue des pierres naturelles les plus recherchées et appréciées, une collection en grès cérame idéales pour transmettre un esprit et une personnalité liés à vos idées de design.

Die edelsten und beliebtesten Natursteine inspirieren zu einer Reihe Feinsteinzeugkollektionen, die Ihre Designideen mit Charakter und Persönlichkeit unterstreichen.

Самые эlegantные и ценные природные камни дают жизнь целому спектру коллекций из керамогранита, которые помогут воплотить в дизайнах интерьеров весь ваш творческий потенциал и яркую индивидуальность.



Stone Look

The collections

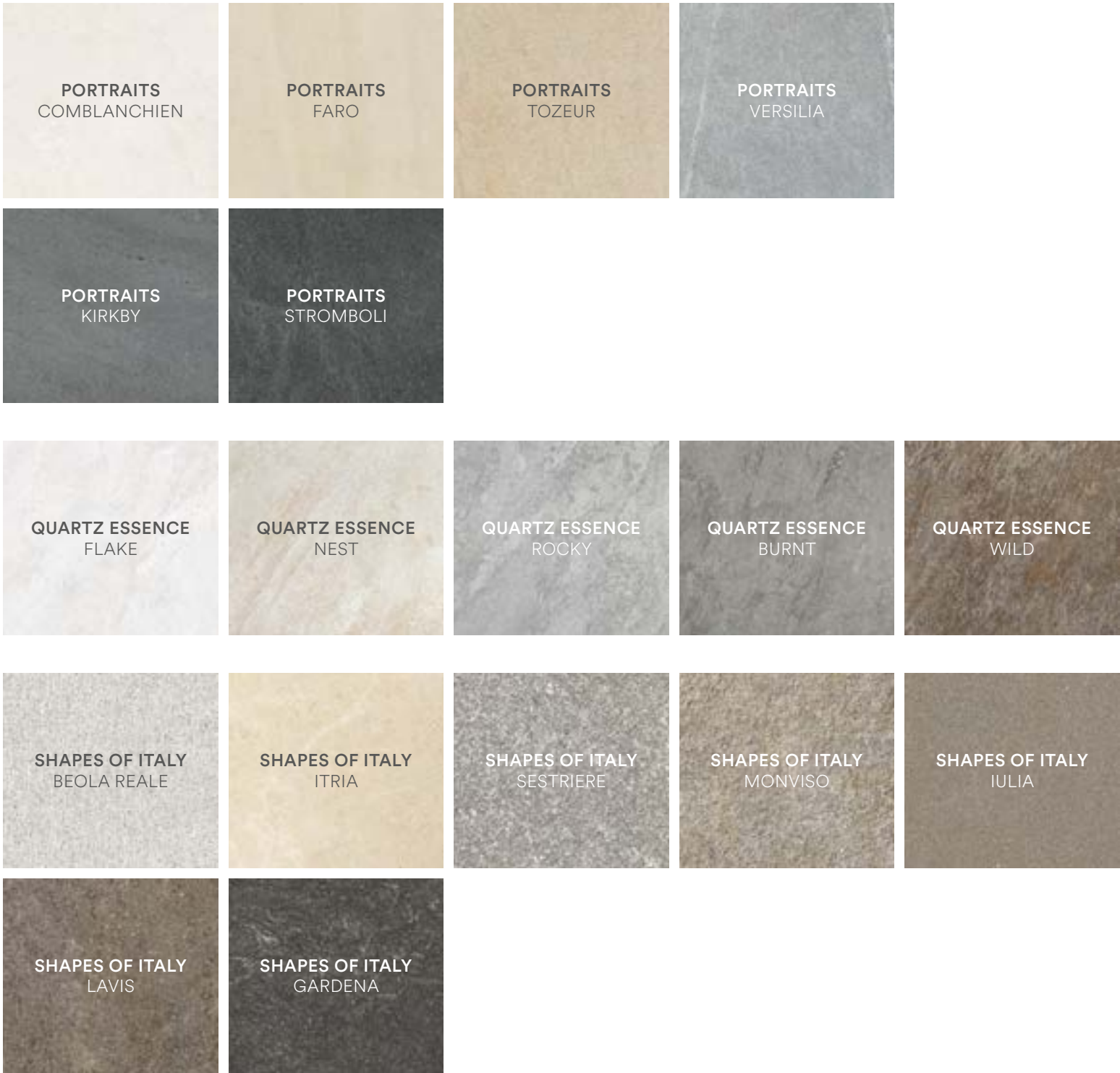
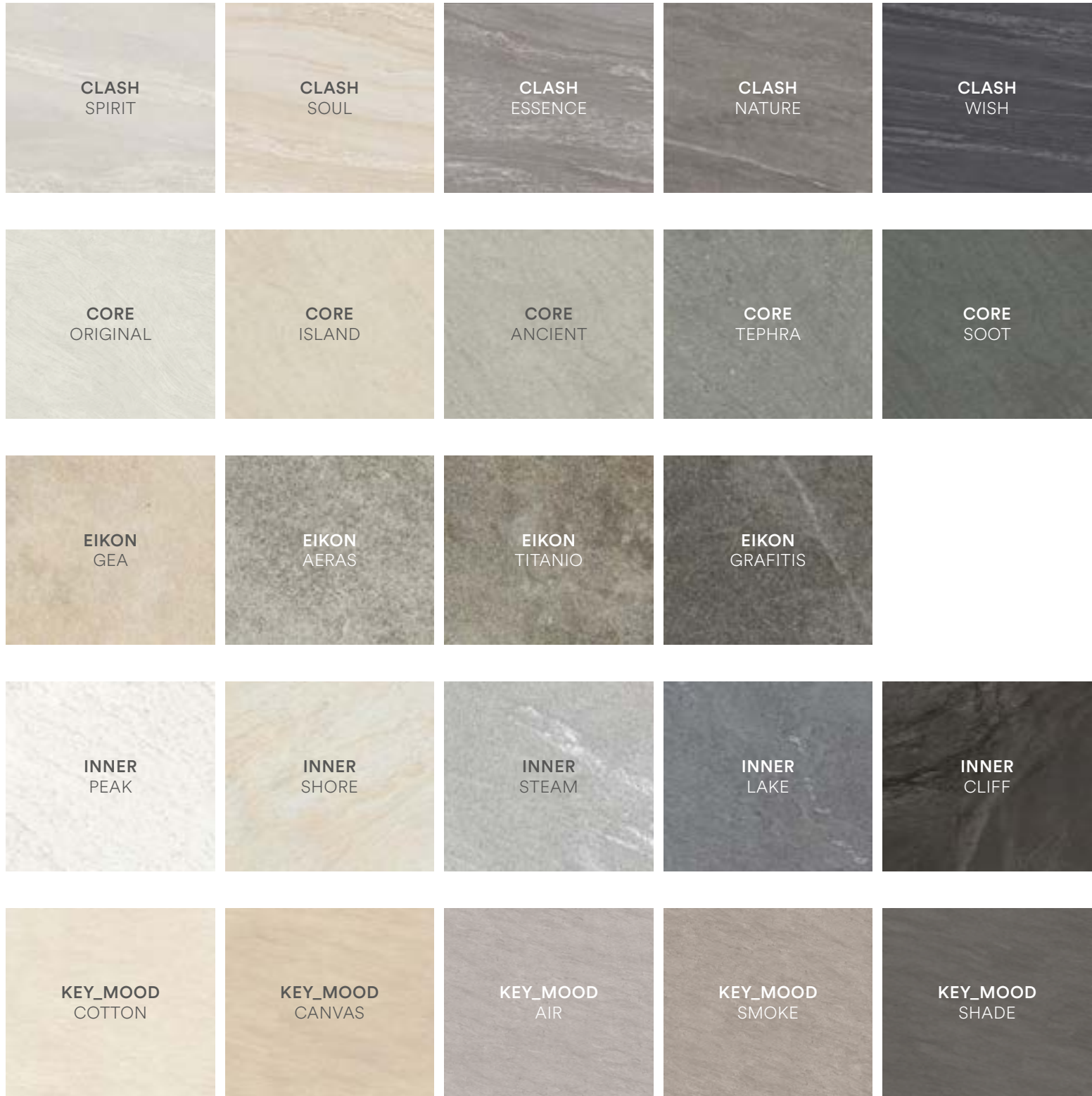

Clash

Strong by nature



Da quarziti antichissime, forgiate dall'azione di forze primordiali della natura, deriva l'ispirazione per una nuova materia ceramica. Clash è il prodotto ideale per coniugare la bellezza istintiva della pietra con le prestazioni impareggiabili del grès porcellanato Caesar.

Age-old quartzite, forged by primeval natural forces, is the inspiration for a new ceramic material. Clash is the ideal product for combining the impulsive beauty of stone with the unparalleled performance of Caesar porcelain stoneware.

Des quartzites remontant à la nuit des temps, forgés par l'action des forces primordiales de la Nature, inspirent une nouvelle matière céramique. Clash est le produit idéal pour conjuguer la beauté instinctive de la pierre avec les prestations incomparables du grès cérame Caesar.

An vorzeitlichen, durch die Urkräfte der Natur geformten Quarziten ist ein neues Keramikmaterial inspiriert. Clash ist das ideale Produkt, wenn die instinktive Schönheit des Natursteins mit den unvergleichlichen Leistungen des Feinsteinzeugs von Caesar vereint werden soll.

Благодаря древнейшим кварцитам, созданным формировавшими нашу планету силами природы, появилось вдохновение для создания нового керамического материала. Clash - великолепно объединяет в себе врожденную красоту камня с несравненными характеристиками керамогранита Caesar.



Info
Resources
Tools



Floor: NATURE 22,5x45,3 TEXTURED NR R11 C

Clash



STONE LOOK

Colori - Formati

Colors - Sizes

60x60 . 30x60 9 mm MATT RT R10 B
30x60 9 mm GRIP RT R11 C
22,5x45,3 9 mm TEXTURED NR R11 C
60x90 . 60x60 20 mm AEXTRA20 RT R11 C

SPIRIT



SOUL



ESSENCE



NATURE



WISH

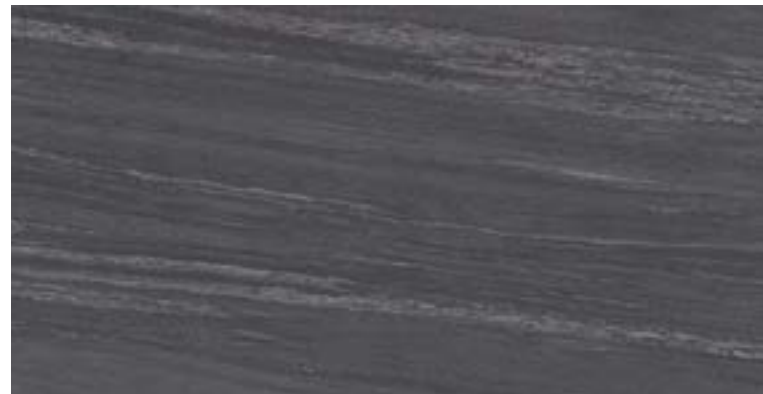

9 mm



60x60
23⁵/₈"x23⁵/₈"



30x60
11¹³/₁₆"x23⁵/₈"

MATT RT R10 B

9 mm



30x60
11¹³/₁₆"x23⁵/₈"

GRIP RT R11 C

9 mm



22,5x45,3
8¹³/₁₆"x17¹³/₁₆"

TEXTURED NR R11 C

20 mm



60x90
23⁵/₈"x35⁷/₁₆"



60x60
23⁵/₈"x23⁵/₈"

AEXTRA20 RT R11 C















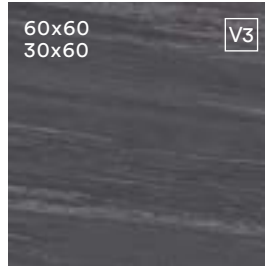

*La liste à jour des produits et formats des séries certifiées QB-UPEC est disponible en usine.

Clash

STONE LOOK

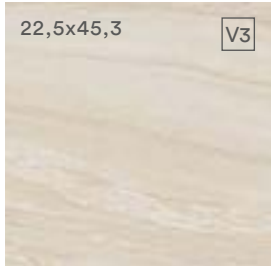
La gamma

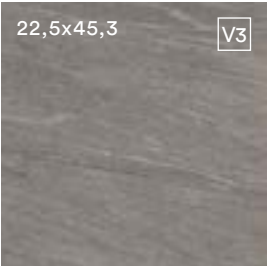
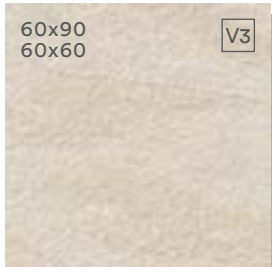
The range

| | SPIRIT | SOUL | ESSENCE  | NATURE  | WISH |
|-------------------|------------------------------------------------------------------------------------|-------------------------------------------------------------------------------------|---------------------------------------------------------------------------------------------|--------------------------------------------------------------------------------------------|--------------------------------------------------------------------------------------|
| MATT RT R10 B |  |  |  |  |  |
| GRIP RT R11 C |  |  |  |  |  |
| TEXTURED NR R11 C | |  |  |  | |
| AEXTRA20 RT R11 C | |  |  |  | |

RT Rettificato, quadrato, monocalibro. - Rectified, squared, one caliber. - Rectifié, mis d'équerre et monocalibre. - Rektifiziert, rechtwinkelig und Ein kaliber. - Ректифицированный, одного калибра.
 NR Non rettificato. - Not rectified. - Non rectifié. - Nicht rektifiziert. - Не ретицированный.

Decori

Decors

COMPOSIZIONE M 30x30 cm . 11¹³/₁₆"x11¹³/₁₆" MATT

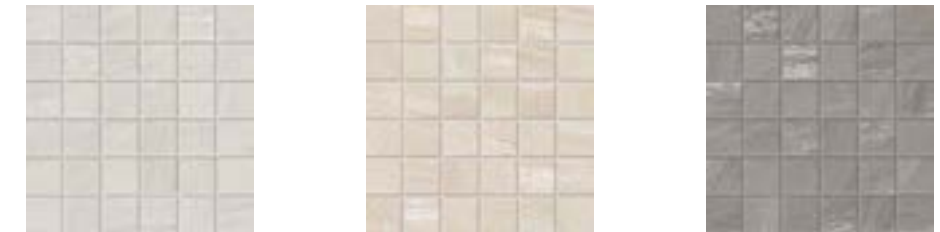

SPIRIT

SOUL

ESSENCE



NATURE

WISH

ARS 30x30 cm . 11¹³/₁₆"x11¹³/₁₆" MATT



SPIRIT

SOUL

ESSENCE



NATURE

WISH

CARATTERISTICHE TECNICHE

TILE PERFORMANCE DATA - NOTES TECHNIQUES - TECHNISCHE AUSKÜNFTE - ТЕХНИЧЕСКАЯ ХАРАКТЕРИСТИКА

Classificazione secondo EN ISO 14411 ISO 13006 annesso G gruppo Bla con Ev ≤0,5% - Classification in accordance with EN ISO 14411 ISO 13006 annex G standards Bla with Ev ≤ 0,5% - Classification selon EN ISO 14411 ISO 13006 annexe G groupe Bla avec Ev ≤0,5% - Klassifizierung gemäß EN ISO 14411 ISO 13006 anlage G Gruppe Bla mit Ev ≤0,5% - Классификация в соответствии с EN ISO 14411 ISO 13006, приложение G, стандарт Bla, где Ev ≤0,5%

| | A E X T R A 2 0 | | A E X T R A 2 0 | | A E X T R A 2 0 | |
|---------|---------------------------------------------------------------------------------------|-----------------------------------------------------------------------------------------|----------------------------------------------------------------------------------------------|-----------------------------------------------------------------------------------------|----------------------------------------------------------------------------------------|----------|
| | 60x60 cm 23 ⁵ / ₈ "x23 ⁵ / ₈ " 9 mm | 30x60 cm 11 ¹³ / ₁₆ "x23 ⁵ / ₈ " 9 mm | 22,5x45,3 cm 8 ¹³ / ₁₆ "x17 ¹³ / ₁₆ " 9 mm | 60x90 cm 23 ⁵ / ₈ "x35 ⁷ / ₁₆ " 20 mm | 60x60 cm 23 ⁵ / ₈ "x23 ⁵ / ₈ " 20 mm | |
| | MATT RT R10 B | MATT RT R10 B | GRIP RT R11 C | TEXTURED NR R11 C | RT R11 C | RT R11 C |
| Spirit | ● | ● | ● | ● | ● | ● |
| Soul | ● | ● | ● | ● | ● | ● |
| Essence | ● | ● | ● | ● | ● | ● |
| Nature | ● | ● | ● | ● | ● | ● |
| Wish | ● | ● | ● | ● | ● | ● |

| | Battiscopa - Bullnose Plinthe - Sockel Плинтус | Scalino - Step tread Nez de marche - Stufe Cotto-Art Фронтальная ступень | Angolare - Step tread corner Pièce angulaire - Stufencke Угловая ступень | Elemento L - Rounded covenosing Nez de marche - "L" Schenkel Элемент L |
|---------|---------------------------------------------------------------------------------|--------------------------------------------------------------------------------|--------------------------------------------------------------------------------|----------------------------------------------------------------------------------------------------------------------|
| | 7,2x60 cm 2 ¹³ / ₁₆ "x23 ⁵ / ₈ " | 33x60 cm 13"x23 ⁵ / ₈ " | 33x33 cm 13"x13" | 16,5x30x3 cm 6 ⁵ / ₈ "x11 ¹³ / ₁₆ "x1 ¹³ / ₁₆ " |
| | MATT | MATT | MATT | TEXTURED |
| Spirit | ● | ● | ● | ● |
| Soul | ● | ● | ● | ● |
| Essence | ● | ● | ● | ● |
| Nature | ● | ● | ● | ● |
| Wish | ● | ● | ● | ● |

| IMBALLI - PACKAGING - CONDITIONNEMENT - VERPACKUNGS-EINHEITEN - УПАКОВКА | | | | | | | |
|--------------------------------------------------------------------------|----------------------------------------------------------------------|------------------------------------------|--------|--------|---------------------------|---------|----------|
| Formato - Size - Format - Формат | | Scatola - Box - Boîte - Karton - Коробка | | | Pallet - Palette - Палета | | |
| CM | INCHES | PZ | MQ | KG | SC | MQ | KG |
| 60x60 | 23 ⁵ / ₈ "x23 ⁵ / ₈ " | 4 | 1,44 | ~28,40 | 30 | 43,20 | ~852,00 |
| 30x60 | 11 ¹³ / ₁₆ "x23 ⁵ / ₈ " | 7 | 1,26 | ~25,00 | 40 | 50,40 | ~1000,00 |
| 22,5x45,3 | 8 ¹³ / ₁₆ "x17 ¹³ / ₁₆ " | 12 | 1,2231 | ~23,70 | 34 | 41,5854 | ~805,80 |
| 60x90 A E X T R A 2 0 | 23 ⁵ / ₈ "x35 ⁷ / ₁₆ " | 2 | 1,08 | ~48,50 | 24 | 25,92 | ~1164,00 |
| 60x60 A E X T R A 2 0 | 23 ⁵ / ₈ "x23 ⁵ / ₈ " | 2 | 0,72 | ~32,00 | 30 | 21,60 | ~960,00 |

RT Rettificato, squadrato, monocalibro. - Rectified, squared, one caliber. - Rectifié, mis d'equerre et monocalibre. - Rektifiziert, rechteckig und Ein kaliber. - Ректифицированный, одного калибра.

NR Non rettificato. - Not rectified. - Non rectifié. - Nicht rektifiziert. - Не ретицированный.

** Disponibile solo su richiesta. - Manufactured only upon special request. - Seulement sur demande. - Nur auf Anfrage. - Производится только по заказу.

Si raccomanda l'utilizzo di una fuga di 2/3 mm al fine di semplificare le operazioni di posa e ottimizzare la naturalezza del risultato finale. - We recommend you a 2/3 mm grout joint to simplify the laying and optimize the naturalness of the final result. - Un joint de 2/3 mm est conseillé afin de simplifier les opérations de pose et optimiser l'effet naturel du résultat final. - Es wird empfohlen mit einer Fuge von 2/3 mm zu arbeiten, um am Ende den Verlegvorgang zu vereinfachen und die bestmögliche Natürlichkeit der Arbeit zu erzielen. - Для облегчения операций укладки и повышения натуральности вида конечного результата рекомендуется выполнять шов шириной 2-3 мм.

Al fine di facilitare la manutenzione ordinaria si raccomanda di effettuare un lavaggio acido dopo 48 ore dalla stuccatura con un acido specifico per grès porcellanato. - In order to favour the ordinary maintenance procedures, it is recommended to carry out an acid wash of the surface after 48 hours from grout filling using an acid agent specific for porcelain stoneware tiles. - Afin de faciliter l'entretien ordinaire de votre carrelage, nous vous conseillons de le laver 48 heures après le colmatage des joints, avec un acide spécifique pour grès cérame. - Um die Instandhaltung zu erleichtern, empfiehlt es sich 48 Stunden nach der Stuckatur mit einer sauren Lösung speziell für Feinsteinzeug zu waschen. - Чтобы упростить уход за плиткой, спустя 48 часов после затирки швов рекомендуется выполнить обработку кислотным продуктом, пригодным для керамогранита.

| | CARATTERISTICA TECNICA TECHNICAL CHARACTERISTIC CARACTERISTIQUE TECHNIQUE TECHNISCHE DATEN ТЕХНИЧЕСКАЯ ХАРАКТЕРИСТИКА | METODO DI PROVA TESTS METHOD METHODE D'ESSAI TESTMETHODE МЕТОД ИСПЫТАНИЯ | VALORE * MEDIO "CAESAR" AVERAGE "CAESAR" VALUE* VALEUR * MOYEN "CAESAR" "CAESAR" DURCHSCHNITTSWERT* СРЕДНЕЕ ЗНАЧЕНИЕ "CAESAR"* | VALORE * MEDIO "CAESAR" AVERAGE "CAESAR" VALUE A E X T R A 2 0 OPEN YOUR STYLE |
|--|------------------------------------------------------------------------------------------------------------------------------------------------------------------------------------------------------------------------------------|--------------------------------------------------------------------------------------|--------------------------------------------------------------------------------------------------------------------------------------------|-----------------------------------------------------------------------------------------------------------------------------------------------------------------------------------------------------------------------------------------------------------------------------------------|
| | Dimensione - Size Dimension - Abmessungen - Размер | ISO 10545-2 | Conforme - In accordance Conforme - Erfüllt - Соответствует | Conforme - In accordance Conforme - Erfüllt - Соответствует |
| | Assorbimento d'acqua* - Water absorption* Absorption d'eau* - Wasseraufnahme* - % Поглощения воды* | ISO 10545-3 | ≤ 0,1% | ≤ 0,1% |
| | Resistenza alla flessione* - Bending strength* Résistance à la flexion* - Biegezugfestigkeit* - Упругость* | ISO 10545-4 | Conforme - In accordance Conforme - Erfüllt - Соответствует | Non applicabile a piastrelle con una forza di rottura Not applicable to tiles with a breaking strength N'est pas applicable aux carreaux avec une charge de rupture Nicht anwendbar bei Fliesen mit einer Bruchlast Не применяется в отношении плиток с прочностью на изрыв |
| | Sforzo di rottura (S) - Breaking strength Charge de rupture - Bruchlast - разрушающее усилие | ISO 10545-4 | Sps ≥ 7,5 mm S ≥ 1300 N | ≥ 3000 N ≥ 3000 N ≥ 3000 N |
| | Resistenza all'abrasione profonda* - Deep scratch resistance* Résistance à l'abrasion profonde* - Widerstand gegen Tiefenverschleiß* Устойчивость к глубокому истиранию* | ISO 10545-6 | Conforme - In accordance Conforme - Erfüllt - Соответствует | ≥ 3000 N ≥ 3000 N ≥ 3000 N |
| | Coefficiente di dilatazione termica lineare* - Thermal linear expansion coefficient* Coefficient de dilatation thermique linéaire - Koeffizient der linearen thermischen Dehnung* - Коэффициент линейного теплового расширения* | ISO 10545-8 | = 7 (10 ⁻⁶ °C ⁻¹) | = 7 (10 ⁻⁶ °C ⁻¹) |
| | Resistenza agli sbalzi termici* - Thermal shock resistance* Résistance aux écarts de température* - Temperaturwechsel Beständigkeit* Устойчивость к тепловому перепаду* | ISO 10545-9 | Resistente - Resistant Résistante - Beständig - Стойкий | Resistente - Resistant Résistante - Beständig - Стойкий |
| | Dilatazione all'umidità* - Expansion in humidity* Dilatation à l'humidité* - Feuchtigkeitsausdehnung* Расширение в условиях влажности* | ISO 10545-10 | ≤ 0,1 (mm/m) | ≤ 0,1 (mm/m) |
| | Resistenza al gelo* - Frost resistance* Résistance au gel* - Frostbeständigkeit* - Морозоустойчивость* | ISO 10545-12 | Resistente - Resistant Résistante - Beständig - Стойкий | Resistente - Resistant Résistante - Beständig - Стойкий |
| | Resistenza all'attacco chimico* - Resistance to chemical attack* Résistance à l'attaque chimique* - Beständigkeit gegen Chemikalien* Устойчивость к химическому воздействию* | ISO 10545-13 | Resistente - Resistant Résistante - Beständig - Стойкий | Resistente - Resistant Résistante - Beständig - Стойкий |
| | Carico statico - Static load Charge statique - Statische Last Статическая нагрузка | EN 12825 | - | 60x60 KN>7,0 60x90 KN>8,0 |
| | Classe di carico di rottura*** - Breaking load class*** Classe de charge de rupture*** - Bruchlastklasse*** Класс стойкости к разрушающей нагрузке*** | EN 1339 | - | Centro - Centre - Au centre - Mitte - По центру Centro lato - Side centre - Au centre latérallement Mitte Seite - По центру грани Diagonale - Diagonal - En diagonale Diagonal - По диагонали |
| | Resistenza alle macchie* - Resistance to stains* Résistance aux taches* - Fleckenbeständigkeit* Устойчивость к образованию пятен* | ISO 10545-14 | Pulibile - Cleanable Nettoyable - Leicht zu reinigen Чистящийся | KN>5,0 KN>6,0 KN>8,0 KN>8,0 |
| | Resistenza allo scivolamento** - Slip resistance** Résistance au glissement** - Rutschhemmende Eigenschaft** Сопротивление скольжению** | DIN 51130 - DIN 51097 | R10 B Matt R11 C Grip R11 C Textured | U11 T11 |
| | Spessore nominale - Nominal Thickness Épaisseur nominal - Nominalstärke Номинальная толщина | ▲ ANSI A326.3 | Wet DCOF ≥ 0,42 Wet DCOF ≥ 0,55 Wet DCOF ≥ 0,55 | Pulibile - Cleanable Nettoyable - Leicht zu reinigen Чистящийся |
| | | | 9 mm | R11 C |
| | | | | Wet DCOF ≥ 0,55 |
| | | | | 20 mm |

* Valori medi riferiti agli ultimi due anni di produzione e relativi alla finitura naturale del prodotto - Average values referred to the last two years of production and related to the matt finish of the product - Valeurs moyennes des deux dernières années de production et relatifs à la finition naturelle du produit - Durchschnittswerte, die sich auf die letzten zwei Produktionsjahre beziehen und auf die matte Oberfläche - Средние значения относятся к последним двум годам производства и натуральной отделке поверхности

** Valori relativi alla finitura naturale del prodotto ed a test effettuati da laboratori esterni accreditati, disponibili in azienda; ci rendiamo disponibili alla verifica dell'eventuale lotto interessato all'acquisto. - As far as values relating to the matt finish of the product and to tests carried out by certified external laboratories whose results are available upon request at Headoffice, we are willing to check the lot you are interested in purchasing. - Valeurs se référant à la finition naturelle du produit selon des tests effectués par des laboratoires extérieurs accrédités et à la disposition de toute personne intéressée auprès de nos bureaux; nous sommes disponibles pour le contrôle de l'éventuel lot concerné par l'achat. - Werte bezogen auf das natürliche Produktfinish und in anerkannten externen Labors geprüft, im Unternehmen erhältlich; für eventuelle Prüfungen der zu erwerbenden Warenposten stehen wir gern zur Verfügung. - Значения, касающиеся натуральных характеристик изделий и тестов, выполненных внешними авторизованными лабораториями, имеются в компании. Мы готовы выполнить проверку партии товара, которую намереваетесь приобрести.

*** Dato riferito al formato 60x60 cm. - Detail referred to the 60x60 cm size. - Donnée se rapportant au format 60x60 cm. - Auf die Formate 60x60 cm bezogen. - Значения, касающиеся натуральных характеристик изделий и тестов.

• Per prodotti chimici di uso domestico e additivi per piscina. - For domestic chemicals and swimming pool additives. - Pour produits chimiques à usage domestique et additifs pour piscines. - Für chemische Produkte für den Hausgebrauch und Schwimmbadzusätze. - Для бытовых химикатов и добавок для бассейнов.

▲ Valori wet DCOF specifici disponibili in azienda - Wet DCOF specific values available at the company - Valeurs wet DCOF spécifiques disponibles à l'usine - Prüfwerte Wet DCOF stehen im Werk zur Verfügung - Показатели wet DCOF доступны при запросе

Le tonalità dei campioni sono da considerarsi puramente indicative. - Tones of samples are indicative. - Les tonalités des échantillons sont purement indicatives. Die farbtöne der Muster sind als rein indicativ zu betrachten. - Тона образцов ориентировочные.

Core

The charm of nature has never been so deep



Un concentrato di forza e purezza che arriva direttamente dal centro della Terra per farsi pietra e avvolgere ciò che ami. Una collezione in grès porcellanato materica, raffinata, elegante nella sua fedele riproduzione della natura, per impreziosire ogni superficie.

A powerhouse of strength and purity that comes directly from the center of the Earth, Core encompasses the beauty of stone that is loved by all. A true replication of a natural material, this porcelain stoneware collection is refined, elegant and ideal for adding a precious feel to any surface.

Un concentré de force et de pureté jaillissant directement des profondeurs de la Terre pour se faire pierre et habiller vos espaces. Une collection en grès cérame matiérique, raffinée et élégante dans sa reproduction fidèle de la nature, qui vient sublimer toutes les surfaces.

Kraft und Reinheit konzentrieren sich direkt aus dem Mittelpunkt der Erde und umgeben alles, was Ihnen lieb und teuer ist. Eine Kollektion aus stofflichem Feinsteinzeug, raffiniert, elegant in ihrer getreuen Reproduktion der Natur, die jede Oberfläche kostbar macht.

Концентрат мощи и чистоты, поступающий прямо из ядра Земли, превращается в камень для отделки любимых вами пространств. Эта изысканная и элегантная коллекция из фактурного керамогранита предназначена для точного воспроизведения натуральных материалов и для подчеркивания красоты любых поверхностей.



Info
Resources
Tools



Colori - Formati

Colors - Sizes

60x120 . 60x60 . 30x60 9 mm MATT RT R10 B

60x60 9 mm TEXTURED RT R11 C

60x120 . 60x60 20 mm AEXTRA20 RT R11 C

ORIGINAL

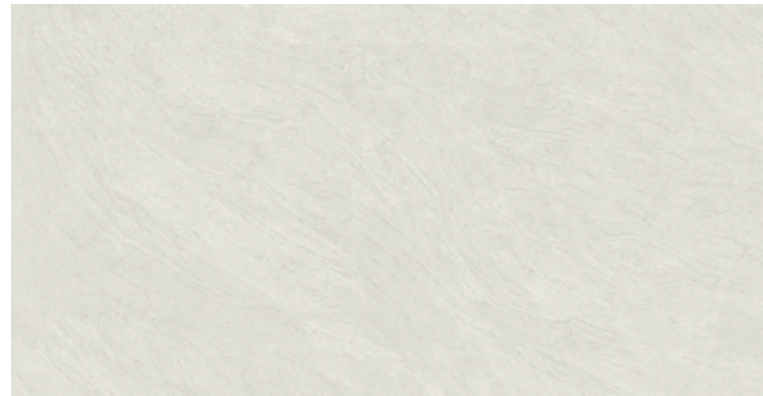

ISLAND



ANCIENT



TEPHRA



SOOT



9 mm



60x120
23⁵/₈"x47⁵/₈"



60x60
23⁵/₈"x23⁵/₈"



30x60
11⁵/₁₆"x23⁵/₈"

MATT RT R10 B

9 mm



60x60
23⁵/₈"x23⁵/₈"

TEXTURED RT R11 C

20 mm



60x120
23⁵/₈"x47⁵/₈"











60x60
23⁵/₈"x23⁵/₈"

AEXTRA20 RT R11 C

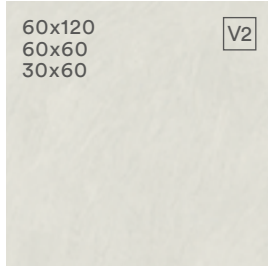
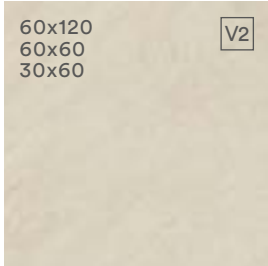
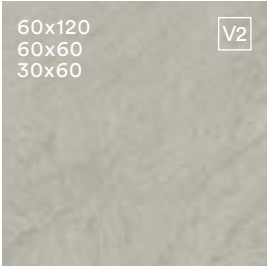
*La liste à jour des produits et formats des séries certifiées QB-UPEC est disponible en usine.

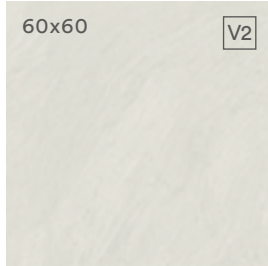
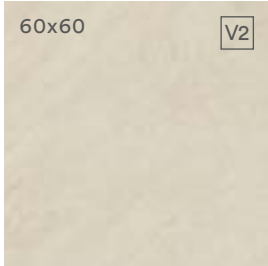
La gamma

The range

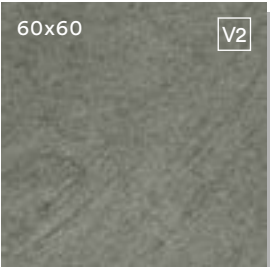
| | ORIGINAL | ISLAND | ANCIENT  | TEPHRA | SOOT  |
|-------------------|---------------------------------------------------------------------------------------------------------------------|---------------------------------------------------------------------------------------------------------------------|----------------------------------------------------------------------------------------------------------------------|-----------------------------------------------------------------------------------------------------------------------|------------------------------------------------------------------------------------------------------------|
| MATT RT R10 B |  <p>60x120 60x60 30x60</p> |  <p>60x120 60x60 30x60</p> |  <p>60x120 60x60 30x60</p> |  <p>60x120 60x60 30x60</p> |  <p>60x60 30x60</p> |
| TEXTURED RT R11 C |  <p>60x60</p> |  <p>60x60</p> |  <p>60x60</p> |  <p>60x60</p> |  <p>60x60</p> |
| AEXTRA20 RT R11 C | | |  <p>60x120 60x60</p> |  <p>60x60</p> | |



Core

Decori

Decors

ARS 30x30 cm . 11¹³/₁₆"x11¹³/₁₆" MATT



ORIGINAL



ISLAND



ANCIENT



TEPHRA



SOOT

COMPOSIZIONE N 30x30 cm . 11¹³/₁₆"x11¹³/₁₆" MATT



ORIGINAL



ISLAND



ANCIENT



TEPHRA



SOOT

STONE LOOK



Wall: ARS TEPHRA 30x30 MATT R10 B

CARATTERISTICHE TECNICHE

TILE PERFORMANCE DATA - NOTES TECHNIQUES - TECHNISCHE AUSKÜNFTE - ТЕХНИЧЕСКАЯ ХАРАКТЕРИСТИКА

Classificazione secondo EN ISO 14411 ISO 13006 annesso G gruppo Bla con Ev ≤0,5% - Classification in accordance with EN ISO 14411 ISO 13006 annex G standards Bla with Ev ≤ 0,5% - Classification selon EN ISO 14411 ISO 13006 annexe G groupe Bla avec Ev ≤0,5% - Klassifizierung gemäß EN ISO 14411 ISO 13006 anlage G Gruppe Bla mit Ev ≤0,5% - Классификация в соответствии с EN ISO 14411 ISO 13006, приложение G, стандарт Bla, где Ev ≤0,5%

| | 60x120 cm 23 ⁵ / ₈ "x47 ² / ₈ " 9 mm | | 60x60 cm 23 ⁵ / ₈ "x23 ⁵ / ₈ " 9 mm | | 30x60 cm 11 ³ / ₈ "x23 ⁵ / ₈ " 9 mm | 60x120 cm 23 ⁵ / ₈ "x47 ² / ₈ " 20 mm | | 60x60 cm 23 ⁵ / ₈ "x23 ⁵ / ₈ " 20 mm |
|----------|----------------------------------------------------------------------------------------|---------------|---------------------------------------------------------------------------------------|---------------|---------------------------------------------------------------------------------------|-----------------------------------------------------------------------------------------|-----------------|----------------------------------------------------------------------------------------|
| | MATT RT R10 B | MATT RT R10 B | TEXTURED RT R11 C | MATT RT R10 B | | RT R11 C | A E X T R A 2 0 | RT R11 C |
| Original | ● | ● | ● | ● | ● | | | |
| Island | ● | ● | ● | ● | ● | | | ● |
| Ancient | ● | ● | ● | ● | ● | ● | | ● |
| Tephra | ● | ● | ● | ● | ● | | | ● |
| Soot | ● | ● | ● | ● | ● | | | ● |

| | 7,2x60 cm 2 ⁷ / ₈ "x23 ⁵ / ₈ " | | 33x120 cm 13"x47 ² / ₈ " | | 33x60 cm 13"x23 ⁵ / ₈ " | 33x33 cm 13"x13" |
|----------|-------------------------------------------------------------------------------|------|---------------------------------------------------|------|--------------------------------------------------|---------------------|
| | MATT | MATT | MATT | MATT | MATT | MATT |
| Original | ● | ● | ● | ● | ● | ● |
| Island | ● | ● | ● | ● | ● | ● |
| Ancient | ● | ● | ● | ● | ● | ● |
| Tephra | ● | ● | ● | ● | ● | ● |
| Soot | ● | ● | ● | ● | ● | ● |

| IMBALLI - PACKAGING - CONDITIONNEMENT - VERPACKUNGS-EINHEITEN - УПАКОВКА | | | | | | | |
|--------------------------------------------------------------------------|-------------------------------------------------------------------|------------------------------------------|------|--------|---------------------------|-------|----------|
| Formato - Size - Format - Формат | | Scatola - Box - Boîte - Karton - Коробка | | | Pallet - Palette - Палета | | |
| CM | INCHES | PZ | MQ | KG | SC | MQ | KG |
| 60x120 | 23 ⁵ / ₈ "x47 ² / ₈ " | 2 | 1,44 | ~30,40 | 35 | 50,40 | ~1064,00 |
| 60x60 | 23 ⁵ / ₈ "x23 ⁵ / ₈ " | 4 | 1,44 | ~28,40 | 30 | 43,20 | ~852,00 |
| 30x60 | 11 ³ / ₈ "x23 ⁵ / ₈ " | 7 | 1,26 | ~25,00 | 40 | 50,40 | ~1000,00 |
| 60x120 A E X T R A 2 0 | 23 ⁵ / ₈ "x47 ² / ₈ " | 1 | 0,72 | ~33,35 | 35 | 25,20 | ~1167,25 |
| 60x60 A E X T R A 2 0 | 23 ⁵ / ₈ "x23 ⁵ / ₈ " | 2 | 0,72 | ~32,00 | 30 | 21,60 | ~960,00 |

RT Rettificato, squadrato, monocalibro. - Rectified, squared, one caliber. - Rectifié, mis d'equerre et monocalibre. - Rektifiziert, rechtwinkeling und Ein kaliber. - Ректифицированный, одна калибра.

** Disponibile solo su richiesta. - Manufactured only upon special request. - Seulement sur demande. - Nur auf Anfrage. - Производится только по заказу.

Si raccomanda l'utilizzo di una fuga di 2/3 mm al fine di semplificare le operazioni di posa e ottimizzare la naturalezza del risultato finale. - We recommend you a 2/3 mm grout joint to simplify the laying and optimize the naturalness of the final result. - Un joint de 2/3 mm est conseillé afin de simplifier les opérations de pose et optimiser l'effet naturel du résultat final. - Es wird empfohlen mit einer Fuge von 2/3 mm zu arbeiten, um am Ende den Verlegevorgang zu vereinfachen und die bestmögliche Natürlichkeit der Arbeit zu erzielen. - Для облегчения операций укладки и повышения натуральности вида конечного результата рекомендуется выполнять шов шириной 2-3 мм.

Al fine di facilitare la manutenzione ordinaria si raccomanda di effettuare un lavaggio acido dopo 48 ore dalla stuccatura con un acido specifico per grès porcellanato. - In order to favour the ordinary maintenance procedures, it is recommended to carry out an acid wash of the surface after 48 hours from grout filling using an acid agent specific for porcelain stoneware tiles. - Afin de faciliter l'entretien ordinaire de votre carrelage, nous vous conseillons de le laver 48 heures après le colmatage des joints, avec un acide spécifique pour grès cérame. - Um die Instandhaltung zu erleichtern, empfiehlt es sich 48 Stunden nach der Stuckatur mit einer sauren Lösung speziell für Feinsteinzeug zu waschen. - Чтобы упростить уход за плиткой, спустя 48 часов после затирки швов рекомендуется выполнить обработку кислотным продуктом, пригодным для керамогранита.

| | CARATTERISTICA TECNICA TECHNICAL CHARACTERISTIC CARACTERISTIQUE TECHNIQUE TECHNISCHE DATEN ТЕХНИЧЕСКАЯ ХАРАКТЕРИСТИКА | METODO DI PROVA TESTS METHOD METHODE D'ESSAI TESTMETHODE МЕТОД ИСПЫТАНИЯ | VALORE * MEDIO "CAESAR" AVERAGE "CAESAR" VALUE * VALEUR * MOYEN "CAESAR" "CAESAR" DURCHSCHNITTSWERT * СРЕДНЕЕ ЗНАЧЕНИЕ "CAESAR" * | VALORE * MEDIO "CAESAR" AVERAGE "CAESAR" VALUE A E X T R A 2 0 OPEN YOUR STYLE |
|--|-------------------------------------------------------------------------------------------------------------------------------------------------------------------------------------------------------------------------------------|--------------------------------------------------------------------------------------|-----------------------------------------------------------------------------------------------------------------------------------------------|-----------------------------------------------------------------------------------------------------------------------------------------------------------------------------------------------------------------------------------------------------------------------------------------|
| | Dimensione - Size Dimension - Abmessungen - Размер | ISO 10545-2 | Conforme - In accordance Conforme - Erfüllt - Соответствует | Conforme - In accordance Conforme - Erfüllt - Соответствует |
| | Assorbimento d'acqua* - Water absorption* Absorption d'eau* - Wasseraufnahme* - % Поглощения воды* | ISO 10545-3 | ≤ 0,1% | ≤ 0,1% |
| | Resistenza alla flessione* - Bending strength* Résistance à la flexion* - Biegezugfestigkeit* - Упругость* | ISO 10545-4 | Conforme - In accordance Conforme - Erfüllt - Соответствует | Non applicabile a piastrelle con una forza di rottura Not applicable to tiles with a breaking strength N'est pas applicable aux carreaux avec une charge de rupture Nicht anwendbar bei Fliesen mit einer Bruchlast Не применяется в отношении плиток с прочностью на изрыв |
| | Sforzo di rottura (S) - Breaking strength Charge de rupture - Bruchlast - Разрушающее усилие | ISO 10545-4 | Sps ≥ 7,5 mm S ≥ 1300 N | > 10.000 N |
| | Resistenza all'abrasione profonda* - Deep scratch resistance* Résistance à l'abrasion profonde* - Widerstand gegen Tiefenverschleiß* Устойчивость к глубокому истиранию* | ISO 10545-6 | Conforme - In accordance Conforme - Erfüllt - Соответствует | Conforme - In accordance Conforme - Erfüllt - Соответствует |
| | Coefficiente di dilatazione termica lineare* - Thermal linear expansion coefficient* Coefficient de dilatation thermique linéaire* - Koeffizient der linearen thermischen Dehnung* - Коэффициент линейного теплового расширения* | ISO 10545-8 | = 7 (10 ⁻⁶ °C ⁻¹) | = 7 (10 ⁻⁶ °C ⁻¹) |
| | Resistenza agli sbalzi termici* - Thermal shock resistance* Résistance aux écarts de température* - Temperaturwechsel Beständigkeit* Устойчивость к тепловому перепаду* | ISO 10545-9 | Resistente - Resistant Résistante - Beständig - Стойкий | Resistente - Resistant Résistante - Beständig - Стойкий |
| | Dilatazione all'umidità* - Expansion in humidity* Dilatation à l'humidité* - Feuchtigkeitsausdehnung* Расширение в условиях влажности* | ISO 10545-10 | ≤ 0,1 (mm/m) | ≤ 0,1 (mm/m) |
| | Resistenza al gelo* - Frost resistance* Résistance au gel* - Frostbeständigkeit* - Морозостойчивость* | ISO 10545-12 | Resistente - Resistant Résistante - Beständig - Стойкий | Resistente - Resistant Résistante - Beständig - Стойкий |
| | Resistenza all'attacco chimico* - Resistance to chemical attack* Résistance à l'attaque chimique* - Beständigkeit gegen Chemikalien* Устойчивость к химическому воздействию* | ISO 10545-13 | Resistente - Resistant Résistante - Beständig - Стойкий | Resistente - Resistant Résistante - Beständig - Стойкий |
| | Carico statico - Static load Charge statique - Statische Last Статическая нагрузка | EN 12825 | - | 60x60 KN>5,0 60x120 KN>5,0 |
| | Classe di carico di rottura*** - Breaking load class*** Classe de charge de rupture*** - Bruchlastklasse*** Класс стойкости к разрушающей нагрузке*** | EN 1339 | - | Centro - Centre - Au centre - Mitte - По центру Centro lato - Side centre - Au centre latéralement Mitte Seite - По центру грани Diagonale - Diagonal - En diagonale Diagonal - По диагонали |
| | Resistenza alle macchie* - Resistance to stains* Résistance aux taches* - Fleckenbeständigkeit* Устойчивость к образованию пятен* | ISO 10545-14 | Pulibile - Cleanable Nettoyable - Leicht zu reinigen Чистящийся | U11 T11 Pulibile - Cleanable Nettoyable - Leicht zu reinigen Чистящийся |
| | Resistenza allo scivolamento** - Slip resistance** Résistance au glissement** - Rutschhemmende Eigenschaft** Сопротивление скольжению** | DIN 51130 - DIN 51097 ▲ ANSI A326.3 | R10 B Matt R11 C Textured Wet DCOF ≥ 0,42 Wet DCOF ≥ 0,55 | R11 C Wet DCOF ≥ 0,55 |
| | Spessore nominale - Nominal Thickness Épaisseur nominal - Nominalstärke Номинальная толщина | | 9 mm | 20 mm |

* Valori medi riferiti agli ultimi due anni di produzione e relativi alla finitura naturale del prodotto - Average values referred to the last two years of production and related to the matt finish of the product - Valeurs moyennes des deux dernières années de production et relatifs à la finition naturelle du produit - Durchschnittswerte, die sich auf die letzten zwei Produktionsjahre beziehen und auf die matte Oberfläche - Средние значения относятся к последним двум годам производства и натуральной отделке поверхности

** Valori relativi alla finitura naturale del prodotto ed a test effettuati da laboratori esterni accreditati, disponibili in azienda; ci rendiamo disponibili alla verifica dell'eventuale lotto interessato all'acquisto. - As far as values relating to the matt finish of the product and to tests carried out by certified external laboratories whose results are available upon request at Headoffice, we are willing to check the lot you are interested in purchasing. - Valeurs se référant à la finition naturelle du produit selon des tests effectués par des laboratoires extérieurs accrédités et à la disposition de toute personne intéressée auprès de nos bureaux; nous sommes disponibles pour le contrôle de l'éventuel lot concerné par l'achat. - Werte bezogen auf das natürliche Produktfinish und in anerkannten externen Labors geprüft, im Unternehmen erhältlich; für eventuelle Prüfungen der zu erwerbenden Warenposten stehen wir gern zur Verfügung. - Значения, касающиеся натуральных характеристик изделий и тестов, выполненных внешними авторизованными лабораториями, имеются в компании. Мы готовы выполнить проверку партии товара, которую намереваетесь приобрести.

*** Dato riferito al formato 60x60 cm. - Detail referred to the 60x60 cm size. - Donnée se rapportant au format 60x60 cm. - Auf die Formate 60x60 cm bezogen. - Значения, касающиеся натуральных характеристик изделий и тестов.

• Per prodotti chimici di uso domestico e additivi per piscina. - For domestic chemicals and swimming pool additives. - Pour produits chimiques à usage domestique et additifs pour piscines. - Für chemische Produkte für den Hausgebrauch und Schwimmbadzusätze. - Для бытовых химикатов и дробавок для бассейнов.

▲ Valori wet DCOF specifici disponibili in azienda - Wet DCOF specific values available at the company - Valeurs wet DCOF spécifiques disponibles à l'usine - Prüfwerte Wet DCOF stehen im Werk zur Verfügung - Показатели wet DCOF доступны при запросе

Le tonalità dei campioni sono da considerarsi puramente indicative. - Tones of samples are indicative. - Les tonalités des échantillons sont purement indicatives. Die farbtöne der Muster sind als rein indicativ zu betrachten. - Тона образцов ориентировочные.

Eikon

Natural inspiration



Caesar rielabora la bellezza intramontabile della pietra, arricchendola di qualità tecniche in termini di resistenza e durata nel tempo. L'ideale per progetti che richiedono elevate performance.

Caesar elaborates the timeless beauty of stone, enriching it with technical features in terms of resistance over time. Ideal for plans requiring high performance products.

Caesar refaçonne la beauté éternelle de la pierre, en l'enrichissant de qualités techniques en termes de résistance et durée dans le temps. L'idéal pour projets qui exigent des performances élevées.

Caesar interpretiert die unvergängliche Schönheit des Natursteins und bereichert sie um die technischen Vorzüge der Beständigkeit und Langlebigkeit. Der ideale Baustoff für Projekte, die hohe Leistungen erfordern.



Info
Resources
Tools

Colori - Formati

Colors - Sizes

30x60 8 mm MATT NR R11 C

45x90 . 60x60 20 mm AEXTRA20 RT R11 C

GEA



AERAS



TITANIO



GRAFITIS



8 mm



30x60
11¹⁵/₁₆"x23⁵/₈"

MATT NR R11 C

20 mm



45x90
17¹¹/₁₆"x35⁷/₁₆"









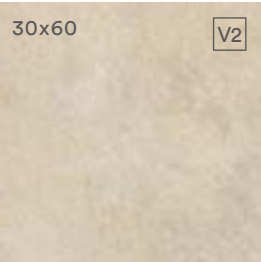

60x60
23⁵/₈"x23⁵/₈"

AEXTRA20 RT R11 C

La gamma

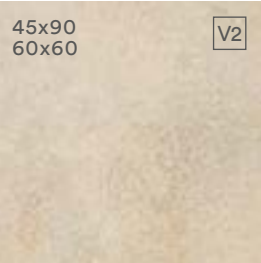
The range

| | GEA | AERAS  | TITANIO  | GRAFITIS  |
|-------------------|---------------------------------------------------------------------------------------|---------------------------------------------------------------------------------------------|-----------------------------------------------------------------------------------------------|------------------------------------------------------------------------------------------------|
| MATT NR R11 C |  |  |  |  |
| AEXTRA20 RT R11 C |  |  |  | |

RT Rettificato, squadrato, monocalibro. - Rectified, squared, one caliber. - Rectifié, mis d'équerre et monocalibre. - Rektifiziert, rechtwinkelig und Ein kaliber. - Ректифицированный, одного калибра.
 NR Non rettificato. - Not rectified. - Non rectifié. - Nicht rektifiziert. - Не ретицированный.

CARATTERISTICHE TECNICHE

TILE PERFORMANCE DATA - NOTES TECHNIQUES - TECHNISCHE AUSKÜNFTE - ТЕХНИЧЕСКАЯ ХАРАКТЕРИСТИКА

Classificazione secondo EN ISO 14411 ISO 13006 annesso G gruppo Bla con Ev ≤0,5 % - Classification in accordance with EN ISO 14411 ISO 13006 annex G standards Bla with Ev ≤ 0,5% - Classification selon EN ISO 14411 ISO 13006 annexe G groupe Bla avec Ev ≤0,5% - Klassifizierung gemäß EN ISO 14411 ISO 13006 anlage G Gruppe Bla mit Ev ≤0,5% - Классификация в соответствии с EN ISO 14411 ISO 13006, приложение G, стандарт Bla, где Ev ≤0,5%

| | A E X T R A 2 0 | | A E X T R A 2 0 | |
|----------|----------------------------------------------------------------------------------------------------------|-------------------------------------------------------------------------------------------------------|----------------------------------------------------------------------------------------------------|--|
| | 30x60 cm 11 ¹³ / ₁₆ "x23 ⁵ / ₈ " 8 mm MATT NR R11 C | 45x90 cm 17 ¹¹ / ₁₆ "x35 ⁷ / ₁₆ " 20 mm RT R11 C | 60x60 cm 23 ⁵ / ₈ "x23 ⁵ / ₈ " 20 mm RT R11 C | |
| Gea | ● | ● | ● | |
| Aeras | ● | ● | ● | |
| Titanio | ● | ● | ● | |
| Grafitis | ● | | | |

| | Elemento L - Rounded covensing Nez de marche - "L" Schenkel Элемент L | |
|----------|-----------------------------------------------------------------------------------------------------------------------------|--|
| | 16,5x30x3 cm 6 ⁷ / ₈ "x11 ¹³ / ₁₆ "x1 ¹ / ₁₆ " MATT | |
| Gea | ● | |
| Aeras | ● | |
| Titanio | ● | |
| Grafitis | ● | |

IMBALLI - PACKAGING - CONDITIONNEMENT - VERPACKUNGS-EINHEITEN - УПАКОВКА

| Formato - Size - Format - Формат | | Scatola - Box - Boîte - Karton - Коробка | | | Pallet - Palette - Палета | | |
|----------------------------------|----------------------------------------------------------------------|------------------------------------------|------|--------|---------------------------|-------|----------|
| CM | INCHES | PZ | MQ | KG | SC | MQ | KG |
| 30x60 | 11 ¹³ / ₁₆ "x23 ⁵ / ₈ " | 8 | 1,44 | ~25,60 | 40 | 57,60 | ~1024,00 |
| 45x90 A E X T R A 2 0 | 17 ¹¹ / ₁₆ "x35 ⁷ / ₁₆ " | 2 | 0,81 | ~36,00 | 27 | 21,87 | ~972,00 |
| 60x60 A E X T R A 2 0 | 23 ⁵ / ₈ "x23 ⁵ / ₈ " | 2 | 0,72 | ~32,00 | 30 | 21,60 | ~960,00 |

RT Rettificato, quadrato, monocalibro. - Rectified, squared, one caliber. - Rectifié, mis d'équerre et monocalibre. - Rektifiziert, rechteckig und Ein kaliber. - Ректифицированный, одного калибра.
NR Non rettificato. - Not rectified. - Non rectifié. - Nicht rektifiziert. - Не ретицированный.

Gli scalini, scalini angolari ed elementi a L non sono calibrati con i fondi di produzione. Hanno mediamente un calibro compreso fra 09 e +2. Sono compatibili ma non identici ai fondi in quanto prodotti con metodi e tecniche diverse. È possibile richiedere la rettifica, per maggiori informazioni rivolgersi ai nostri uffici commerciali. Si raccomanda di seguire attentamente le istruzioni di posa e le avvertenze riportate in ogni scatola. - Steps, corner steps and L elements are not calibrated according to the backdrops. They feature an average work-size ranging from 09 to +2. They are compatible with the backdrops but they are not identical, as they are produced using different manufacturing methods and techniques. They can be rectified upon request, for further information please contact our commercial division. We recommend you carefully follow the installation instructions and advice provided in each box. - Les «Scalino» - «Scalino Angolare» - «Elemento à "L"» ont un calibre qui est compris entre le calibre 09 et le calibre +2. Ils ne sont donc pas du même calibre que les fonds de la même série d'appartenance. Ceci est du au fait de la diversité des techniques de production, du fait de la possibilité de calibres différents des fonds, de la différence de possibilité de pose (pose avec du 45x45, du 30x60 sur la longueur 60, pose en diagonale du fond etc.). Les «Scalino» - «Scalino Angolare» - «Elemento à "L"» sont compatibles avec la tonalité des fonds mais non identiques et/ou similaires. Ceci est du au fait de la leur production en un seul bloc avec des techniques de presse différentes de celles de la production des fonds. Pour la pose des «Scalino», des «scalino angolare» ceux-ci doivent être posés en respectant les règles de pose qui se trouvent dans chaque boîte. - Die Treppenteile, die Treppeneckstücke und die L-Elemente sind mit den Untergründen nicht kalibriert. Im Durchschnitt verfügen sie über ein Kaliber von 09 bis +2. Sie sind kombinierbar aber in Bezug auf die Untergründe aufgrund unterschiedlicher Methoden und Techniken nicht identisch. Auf Anfrage können sie auch geschliffen werden; für weitere Informationen wenden Sie sich bitte an unsere Verkaufsbüros. Wir empfehlen auch aufmerksam unseren Verlegetechniken und die Hinweise in jeder Schachtel zu befolgen.

La stonizzazione cromatica della superficie evidenzia la naturalezza del prodotto; per ottenere un effetto naturale si raccomanda di posare il prodotto con almeno 3 mm di fuga, attingendo contemporaneamente da almeno 4/5 scatole di materiale. - The variable colours of the surface enhance the natural appearance of the product. To obtain the natural effect, we recommend a grouting joint of at least 3 mm. Tiles should be picked from at least 4-5 boxes and mixed. - La variabilité chromatique de la surface met en relief le caractère naturel du produit; pour obtenir un effet naturel, nous vous conseillons de poser le produit avec au moins 3 mm de joint, en puisant simultanément dans 4/5 boîtes de matériel. - Die farblichen Gegensätze der Oberflächen unterstreicht die Natürlichkeit des Produktes. Zur Erzielung eines natürlichen Effekts wird empfohlen, die Fliesen mit wenigstens 3 mm Fuge zu verlegen und abwechselnd Teile aus 4-5 Packungen zu verwenden. - Различные оттенки на поверхности усиливают естественный вид продукта. Чтобы достичь естественного эффекта, мы рекомендуем укладывать плитку со швом не менее 3 мм. Плитка должна быть отобрана не менее чем из 4-5 коробок и перемешана.

Al fine di facilitare la manutenzione ordinaria si raccomanda di effettuare un lavaggio acido dopo 48 ore dalla stuccatura con un acido specifico per grès porcellanato. - In order to favour the ordinary maintenance procedures, it is recommended to carry out an acid wash of the surface after 48 hours from grout filling using an acid agent specific for porcelain stoneware tiles. Afin de faciliter l'entretien ordinaire de votre carrelage, nous vous conseillons de le laver 48 heures après le colmatage des joints, avec un acide spécifique pour grès cérame. - Um die Instandhaltung zu erleichtern, empfiehlt es sich 48 Stunden nach der Stuckatur mit einer sauren Lösung speziell für Feinsteinzeug zu waschen. - Чтобы упростить уход за плиткой, спустя 48 часов после затирки швов рекомендуется выполнить обработку кислотным продуктом, пригодным для керамогранита.

| | CARATTERISTICA TECNICA TECHNICAL CHARACTERISTIC CARACTERISTIQUE TECHNIQUE TECHNISCHE DATEN ТЕХНИЧЕСКАЯ ХАРАКТЕРИСТИКА | METODO DI PROVA TESTS METHOD METHODE D'ESSAI TESTMETHODE МЕТОД ИСПЫТАНИЯ | VALORE * MEDIO "CAESAR" AVERAGE "CAESAR" VALUE * VALEUR * MOYEN "CAESAR" "CAESAR" DURCHSCHNITTSWERT * СРЕДНЕЕ ЗНАЧЕНИЕ "CAESAR" * | VALORE * MEDIO "CAESAR" AVERAGE "CAESAR" VALUE A E X T R A 2 0 OPEN YOUR STYLE |
|--|-------------------------------------------------------------------------------------------------------------------------------------------------------------------------------------------------------------------------------------------|--------------------------------------------------------------------------------------|-----------------------------------------------------------------------------------------------------------------------------------------------|---------------------------------------------------------------------------------------------------------------------------------------------------------------------------------------------------------------------------------------------------------------------------------------------------------------------------------------------|
| | Dimensione - Size Dimension - Abmessungen - Размер | ISO 10545-2 | Conforme - In accordance Conforme - Erfüllt - Соответствует | Conforme - In accordance Conforme - Erfüllt - Соответствует |
| | Assorbimento d'acqua* - Water absorption* Absorption d'eau* - Wasseraufnahme* - % Поглощения воды* | ISO 10545-3 | ≤ 0,1% | ≤ 0,1% |
| | Resistenza alla flessione* - Bending strength* Résistance à la flexion* - Biegezugfestigkeit* - Упругость* | ISO 10545-4 | Conforme - In accordance Conforme - Erfüllt - Соответствует | Non applicabile a piastrelle con una forza di rottura ≥ 3000 N Not applicable to tiles with a breaking strength ≥ 3000 N N'est pas applicable aux carreaux avec une charge de rupture ≥ 3000 N Nicht anwendbar bei Fliesen mit einer Bruchlast ≥ 3000 N Не применяется в отношении плиток с прочностью на азрыв ≥ 3000 N |
| | Sforzo di rottura (S) - Breaking strength Charge de rupture - Bruchlast - разрушающее усилие | ISO 10545-4 | Sps ≥ 7,5 mm S ≥ 1300 N | > 10.000 N |
| | Resistenza all'abrasione profonda* - Deep scratch resistance* Résistance à l'abrasion profonde* - Widerstand gegen Tiefenverschleiß* Устойчивость к глубокому истиранию* | ISO 10545-6 | Conforme - In accordance Conforme - Erfüllt - Соответствует | Conforme - In accordance Conforme - Erfüllt - Соответствует |
| | Coefficiente di dilatazione termica lineare* - Thermal linear expansion coefficient* Coefficient de dilatation thermique linéaire - Koeffizient der linearen thermischen Dehnung* - Коэффициент линейного теплового расширения* | ISO 10545-8 | = 7 (10 ⁻⁶ °C ⁻¹) | = 7 (10 ⁻⁶ °C ⁻¹) |
| | Resistenza agli sbalzi termici* - Thermal shock resistance* Résistance aux écarts de température* - Temperaturwechsel Beständigkeit* Устойчивость к тепловому перепаду* | ISO 10545-9 | Resistente - Resistant Résistante - Beständig - Стойкий | Resistente - Resistant Résistante - Beständig - Стойкий |
| | Dilatazione all'umidità* - Expansion in humidity* Dilatation à l'humidité* - Feuchtigkeitsausdehnung* Расширение в условиях влажности* | ISO 10545-10 | ≤ 0,1 (mm/m) | ≤ 0,1 (mm/m) |
| | Resistenza al gelo* - Frost resistance* Résistance au gel* - Frostbeständigkeit* - Морозоустойчивость* | ISO 10545-12 | Resistente - Resistant Résistante - Beständig - Стойкий | Resistente - Resistant Résistante - Beständig - Стойкий |
| | Resistenza all'attacco chimico • - Resistance to chemical attack • Résistance à l'attaque chimique • - Beständigkeit gegen Chemikalien • Устойчивость к химическому воздействию • | ISO 10545-13 | Resistente - Resistant Résistante - Beständig - Стойкий | Resistente - Resistant Résistante - Beständig - Стойкий |
| | Carico statico - Static load Charge statique - Statische Last Статическая нагрузка | EN 12825 | - | 60x60 KN>7,0 45x90 KN>5,0 |
| | Classe di carico di rottura*** - Breaking load class*** Classe de charge de rupture*** - Bruchlastklasse*** Класс стойкости к разрушающей нагрузке*** | EN 1339 | - | Centro - Centre - Au centre - Mitte - По центру KN>7,0 Centro lato - Side centre - Au centre latéralement KN>5,0 Mitte Seite - По центру грани KN>4,0 Diagonale - Diagonal - En diagonale KN>8,0 Diagonal - По диагонали KN>7,0 |
| | Resistenza alle macchie* - Resistance to stains* Résistance aux taches* - Fleckenbeständigkeit * Устойчивость к образованию пятен* | ISO 10545-14 | Pulibile - Cleanable Nettoyable - Leicht zu reinigen Чистящийся | U11 T11 Pulibile - Cleanable Nettoyable - Leicht zu reinigen Чистящийся |
| | Resistenza allo scivolamento** - Slip resistance** Résistance au glissement** - Rutschhemmende Eigenschaft** Сопротивление скольжению** | DIN 51130 DIN 51097 | R11 C Matt | R11 C |
| | Spessore nominale - Nominal Thickness Épaisseur nominal - Nominalstärke Номинальная толщина | ▲ ANSI A326.3 | Wet DCOF ≥ 0,55 | Wet DCOF ≥ 0,55 |
| | | | 8 mm | 20 mm |

* Valori medi riferiti agli ultimi due anni di produzione e relativi alla finitura naturale del prodotto - Average values referred to the last two years of production and related to the matt finish of the product - Valeurs moyennes des deux dernières années de production et relatifs à la finition naturelle du produit - Durchschnittswerte, die sich auf die letzten zwei Produktionsjahre beziehen und auf die matte Oberfläche - Средние значения относятся к последним двум годам производства и натуральной отделке поверхности

** Valori relativi alla finitura naturale del prodotto ed a test effettuati da laboratori esterni accreditati, disponibili in azienda; ci rendiamo disponibili alla verifica dell'eventuale lotto interessato all'acquisto. - As far as values relating to the matt finish of the product and to tests carried out by certified external laboratories whose results are available upon request at Headoffice, we are willing to check the lot you are interested in purchasing. - Valeurs se référant à la finition naturelle du produit selon des tests effectués par des laboratoires extérieurs accrédités et à la disposition de toute personne intéressée auprès de nos bureaux; nous sommes disponibles pour le contrôle de l'éventuel lot concerné par l'achat. - Werte bezogen auf das natürliche Produktfinish und in anerkannten externen Labors geprüft, im Unternehmen erhältlich; für eventuelle Prüfungen der zu erwerbenden Warenposten stehen wir gern zur Verfügung. - Значения, касающиеся натуральных характеристик изделий и тестов, выполненных внешними авторизованными лабораториями, имеются компании. Мы готовы выполнить проверку партии товара, которую намереваетесь приобрести.

*** Dato riferito al formato 60x60 cm. - Detail referred to the 60x60 cm size. - Donnée se rapportant au format 60x60 cm. - Auf die Formate 60x60 cm bezogen. - Значения, касающиеся натуральных характеристик изделий и тестов.

• Per prodotti chimici di uso domestico e additivi per piscina. - For domestic chemicals and swimming pool additives. - Pour produits chimiques à usage domestique et additifs pour piscines. - Für chemische Produkte für den Hausgebrauch und Schwimmbadzusätze. - Для бытовых химикатов и добавок для бассейнов.

▲ Valori wet DCOF specifici disponibili in azienda - Wet DCOF specific values available at the company - Valeurs wet DCOF spécifiques disponibles à l'usine - Prüfwerte Wet DCOF stehen im Werk zur Verfügung - Показатели wet DCOF доступны при запросе

Le tonalità dei campioni sono da considerarsi puramente indicative. - Tones of samples are indicative. - Les tonalités des échantillons sont purement indicatives. Die farböne der Muster sind als rein indicativ zu betrachten. - Тона образцов ориентировочные.

Inner

At the heart of your nature



Dal cuore della pietra, un linguaggio autentico racconta dell'eleganza senza tempo della Natura. Ispirandosi alla quarzite, il grès porcellanato INNER reinterpreta questo linguaggio in chiave contemporanea e, attraversando le emozioni, arriva al cuore della nostra natura più intima.

From the very heart of stone, a method of communication narrates the timeless elegance of nature. Inspired by quartzite, INNER reinterprets this language in a contemporary way, and through the emotions, reaches the heart of our innermost self.

Au cœur de la pierre, un langage authentique narre l'élégance éternelle de la Nature. En s'inspirant au quartzite, le Grès cérame INNER réinterprète ce langage dans un style contemporain qui, en pénétrant les émotions, arrive au cœur de notre nature la plus intime.

Auch Steine haben ein Herz. Und eine authentische Sprache, die von der zeitlosen Eleganz der Natur erzählt. Das am Quarzit inspirierte Feinsteinzeug INNER interpretiert diese Sprache in zeitgenössischem Stil neu. Und weckt Emotionen, die direkt das Herz unserer innersten Natur erreichen.

Вещественная красота камня глубоко отражает вневременную элегантность природы. Именно эту красоту воссоздает в своей кварцитово-фактурной керамогранит INNER, будоража самые глубокие чувства.



Info
Resources
Tools



Floor: CLIFF 60x60 MATT RT

Inner



STONE LOOK

Colori - Formati

Colors - Sizes

60x120 . 30x120 . 60x60 . 30x60 9 mm MATT RT

30x60 9 mm GRIP RT R11 B

PEAK



SHORE



STEAM



LAKE



CLIFF

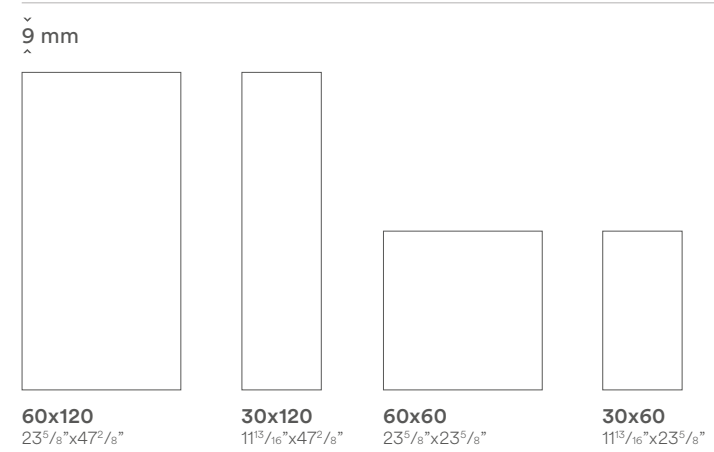

MATT RT



GRIP RT R11 B









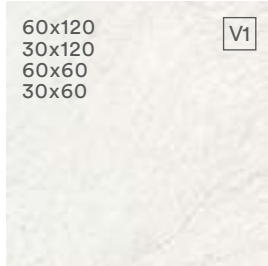
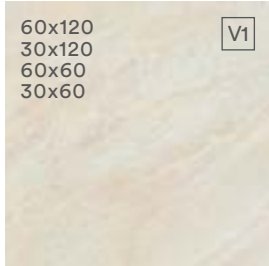

*La liste à jour des produits et formats des séries certifiées QB-UPEC est disponible en usine.

Inner

STONE LOOK

La gamma

The range

| | PEAK | SHORE | STEAM  | LAKE  | CLIFF  |
|---------------|------------------------------------------------------------------------------------------------------------------------------------------|------------------------------------------------------------------------------------------------------------------------------------------|-------------------------------------------------------------------------------------------------------------------------------------------|----------------------------------------------------------------------------------------------------------------------|--------------------------------------------------------------------------------------------------------------------------------------------|
| MATT RT |  <p>60x120 30x120 60x60 30x60</p> <p>V1</p> |  <p>60x120 30x120 60x60 30x60</p> <p>V1</p> |  <p>60x120 30x120 60x60 30x60</p> <p>V1</p> |  <p>60x60 30x60</p> <p>V1</p> |  <p>60x120 30x120 60x60 30x60</p> <p>V1</p> |
| GRIP RT R11 B |  <p>30x60</p> <p>V1</p> |  <p>30x60</p> <p>V1</p> |  <p>30x60</p> <p>V1</p> |  <p>30x60</p> <p>V1</p> |  <p>30x60</p> <p>V1</p> |

Decori

Decors

COMPOSIZIONE M 30x30 cm . 11¹³/₁₆"x11¹³/₁₆" MATT



PEAK

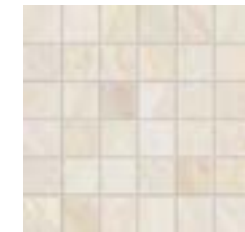

SHORE

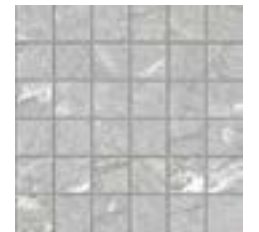

STEAM



LAKE



CLIFF

CARATTERISTICHE TECNICHE

TILE PERFORMANCE DATA - NOTES TECHNIQUES - TECHNISCHE AUSKÜNFTE - ТЕХНИЧЕСКАЯ ХАРАКТЕРИСТИКА

Classificazione secondo EN ISO 14411 ISO 13006 annesso G gruppo Bla con Ev ≤0,5% - Classification in accordance with EN ISO 14411 ISO 13006 annex G standards Bla with Ev ≤ 0,5% - Classification selon EN ISO 14411 ISO 13006 annexe G groupe Bla avec Ev ≤0,5% - Klassifizierung gemäß EN ISO 14411 ISO 13006 anlage G Gruppe Bla mit Ev ≤0,5% - Классификация в соответствии с EN ISO 14411 ISO 13006, приложение G, стандарт Bla, где Ev ≤0,5%

| | 60x120 cm 23 ⁵ / ₈ "x47 ² / ₈ " 9 mm MATT RT | 30x120 cm 11 ³ / ₈ "x47 ² / ₈ " 9 mm MATT RT | 60x60 cm 23 ⁵ / ₈ "x23 ⁵ / ₈ " 9 mm MATT RT | 30x60 cm 11 ³ / ₈ "x23 ⁵ / ₈ " 9 mm MATT RT | GRIP RT R11 B |
|-------|---------------------------------------------------------------------------------------------------|---------------------------------------------------------------------------------------------------|--------------------------------------------------------------------------------------------------|--------------------------------------------------------------------------------------------------|---------------|
| Peak | ● | ● | ● | ● | ● |
| Lake | ● | ● | ● | ● | ● |
| Steam | ● | ● | ● | ● | ● |
| Shore | ● | ● | ● | ● | ● |
| Cliff | ● | ● | ● | ● | ● |

| | Battiscopa - Bullnose Piñthe - Sockel Плинтус 7,2x60 cm 2 ³ / ₈ "x23 ⁵ / ₈ " MATT | Scalino - Step tread Nez de marche - Stufe Cotto-Art Фронтальная ступень 33x60 cm 13"x23 ⁵ / ₈ " MATT | Angolare - Step tread corner Pièce angulaire - Stufencke Угловая ступень 33x33 cm 13"x13" MATT |
|-------|----------------------------------------------------------------------------------------------------------------------------------------------|--------------------------------------------------------------------------------------------------------------------------------------------|---------------------------------------------------------------------------------------------------------------|
| Peak | ● | ● | ● |
| Lake | ● | ● | ● |
| Steam | ● | ● | ● |
| Shore | ● | ● | ● |
| Cliff | ● | ● | ● |

| IMBALLI - PACKAGING - CONDITIONNEMENT - VERPACKUNGS-EINHEITEN - УПАКОВКА | | | | | | | |
|--------------------------------------------------------------------------|-------------------------------------------------------------------|------------------------------------------|------|--------|---------------------------|-------|----------|
| Formato - Size - Format - Формат | | Scatola - Box - Boîte - Karton - Коробка | | | Pallet - Palette - Палета | | |
| CM | INCHES | PZ | MQ | KG | SC | MQ | KG |
| 60x120 | 23 ⁵ / ₈ "x47 ² / ₈ " | 2 | 1,44 | ~31,33 | 35 | 50,40 | ~1096,55 |
| 30x120 | 11 ³ / ₈ "x47 ² / ₈ " | 4 | 1,44 | ~31,32 | 16 | 23,04 | ~501,12 |
| 60x60 | 23 ⁵ / ₈ "x23 ⁵ / ₈ " | 4 | 1,44 | ~28,40 | 30 | 43,20 | ~852,00 |
| 30x60 | 11 ³ / ₈ "x23 ⁵ / ₈ " | 7 | 1,26 | ~25,00 | 40 | 50,40 | ~1000,00 |

RT Rettificato, squadrato, monocalibro. - Rectified, squared, one caliber. - Rectifié, mis d'equerre et monocalibre. - Rektifiziert, rechteckig und Ein kaliber. - Ректифицированный, одна калибра.
 ** Disponibile solo su richiesta. - Manufactured only upon special request. - Seulement sur demande. - Nur auf Anfrage. - Производится только по заказу.

Si raccomanda l'utilizzo di una fuga di 2/3 mm al fine di semplificare le operazioni di posa e ottimizzare la naturalezza del risultato finale. - We recommend you a 2/3 mm grout joint to simplify the laying and optimize the naturalness of the final result. - Un joint de 2/3 mm est conseillé afin de simplifier les opérations de pose et optimiser l'effet naturel du résultat final. - Es wird empfohlen mit einer Fuge von 2/3 mm zu arbeiten, um am Ende den Verlegvorgang zu vereinfachen und die bestmögliche Natürlichkeit der Arbeit zu erzielen. - Для облегчения операций укладки и повышения натуральности вида конечного результата рекомендуется выполнять шов шириной 2-3 мм.

Al fine di facilitare la manutenzione ordinaria si raccomanda di effettuare un lavaggio acido dopo 48 ore dalla stuccatura con un acido specifico per grès porcellanato. - In order to favour the ordinary maintenance procedures, it is recommended to carry out an acid wash of the surface after 48 hours from grout filling using an acid agent specific for porcelain stoneware tiles. - Afin de faciliter l'entretien ordinaire de votre carrelage, nous vous conseillons de le laver 48 heures après le colmatage des joints, avec un acide spécifique pour grès cérame. - Um die Instandhaltung zu erleichtern, empfiehlt es sich 48 Stunden nach der Stuckatur mit einer sauren Lösung speziell für Feinsteinzeug zu waschen. - Чтобы упростить уход за плиткой, спустя 48 часов после затирки швов рекомендуется выполнить обработку кислотным продуктом, пригодным для керамогранита.

| | CARATTERISTICA TECNICA TECHNICAL CHARACTERISTIC CARACTERISTIQUE TECHNIQUE TECHNISCHE DATEN ТЕХНИЧЕСКАЯ ХАРАКТЕРИСТИКА | METODO DI PROVA TESTS METHOD METHODE D'ESSAI TESTMETHODE МЕТОД ИСПЫТАНИЯ | VALORE * MEDIO "CAESAR" AVERAGE "CAESAR" VALUE* VALEUR * MOYEN "CAESAR" "CAESAR" DURCHSCHNITTSWERT* СРЕДНЕЕ ЗНАЧЕНИЕ "CAESAR"* |
|--|------------------------------------------------------------------------------------------------------------------------------------------------------------------------------------------------------------------------------------|--------------------------------------------------------------------------------------|--------------------------------------------------------------------------------------------------------------------------------------------|
| | Dimensione - Size Dimension - Abmessungen - Размер | ISO 10545-2 | Conforme - In accordance Conforme - Erfüllt - Соответствует |
| | Assorbimento d'acqua* - Water absorption* Absorption d'eau* - Wasseraufnahme* - % Поглощения воды* | ISO 10545-3 | ≤ 0,1% |
| | Resistenza alla flessione* - Bending strength* Résistance à la flexion* - Biegezugfestigkeit* - Упругость* | ISO 10545-4 | Conforme - In accordance Conforme - Erfüllt - Соответствует |
| | Sforzo di rottura (S) - Breaking strength Charge de rupture - Bruchlast - разрушающее усилие | ISO 10545-4 | Sps ≥ 7,5 mm S ≥ 1300 N |
| | Resistenza all'abrasione profonda* - Deep scratch resistance* Résistance à l'abrasion profonde* - Widerstand gegen Tiefenverschleiß* Устойчивость к глубокому истиранию* | ISO 10545-6 | Conforme - In accordance Conforme - Erfüllt - Соответствует |
| | Coefficiente di dilatazione termica lineare* - Thermal linear expansion coefficient* Coefficient de dilatation thermique linéaire - Koeffizient der linearen thermischen Dehnung* - Коэффициент линейного теплового расширения* | ISO 10545-8 | ≈ 7 (10 ⁻⁶ °C ⁻¹) |
| | Resistenza agli sbalzi termici* - Thermal shock resistance* Résistance aux écarts de température* - Temperaturwechsel Beständigkeit* Устойчивость к тепловому перепаду* | ISO 10545-9 | Resistente - Resistant Résistante - Beständig - Стойкий |
| | Dilatazione all'umidità* - Expansion in humidity* Dilatation à l'humidité* - Feuchtigkeitsausdehnung* Расширение в условиях влажности* | ISO 10545-10 | ≤ 0,1 (mm/m) |
| | Resistenza al gelo* - Frost resistance* Résistance au gel* - Frostbeständigkeit* - Морозостойчивость* | ISO 10545-12 | Resistente - Resistant Résistante - Beständig - Стойкий |
| | Resistenza all'attacco chimico* - Resistance to chemical attack* Résistance à l'attaque chimique* - Beständigkeit gegen Chemikalien* Устойчивость к химическому воздействию* | ISO 10545-13 | Resistente - Resistant Résistante - Beständig - Стойкий |
| | Carico statico - Static load Charge statique - Statische Last Статическая нагрузка | EN 12825 | - |
| | Classe di carico di rottura*** - Breaking load class*** Classe de charge de rupture*** - Bruchlastklasse*** Класс стойкости к разрушающей нагрузке*** | EN 1339 | - |
| | Resistenza alle macchie* - Resistance to stains* Résistance aux taches* - Fleckenbeständigkeit* Устойчивость к образованию пятен* | ISO 10545-14 | Pulibile - Cleanable Nettoyable - Leicht zu reinigen Чистящийся |
| | Resistenza allo scivolamento** - Slip resistance** Résistance au glissement** - Rutschhemmende Eigenschaft** Сопротивление скольжению** | DIN 51130 - DIN 51097 | R10 A Matt |
| | | ▲ ANSI A326.3 | Wet DCOF ≥ 0,42 |
| | Spessore nominale - Nominal Thickness Épaisseur nominale - Nominalstärke Номинальная толщина | | 9 mm |

* Valori medi riferiti agli ultimi due anni di produzione e relativi alla finitura naturale del prodotto - Average values referred to the last two years of production and related to the matt finish of the product - Valeurs moyennes des deux dernières années de production et relatifs à la finition naturelle du produit - Durchschnittswerte, die sich auf die letzten zwei Produktionsjahre beziehen und auf die matte Oberfläche - Средние значения относятся к последним двум годам производства и натуральной отделке поверхности

** Valori relativi alla finitura naturale del prodotto ed a test effettuati da laboratori esterni accreditati, disponibili in azienda; ci rendiamo disponibili alla verifica dell'eventuale lotto interessato all'acquisto. - As far as values relating to the matt finish of the product and to tests carried out by certified external laboratories whose results are available upon request at Headoffice, we are willing to check the lot you are interested in purchasing. - Valeurs se référant à la finition naturelle du produit selon des tests effectués par des laboratoires extérieurs accrédités et à la disposition de toute personne intéressée auprès de nos bureaux; nous sommes disponibles pour le contrôle de l'éventuel lot concerné par l'achat. - Werte bezogen auf das natürliche Produktfinish und in anerkannten externen Labors geprüft, im Unternehmen erhältlich; für eventuelle Prüfungen der zu erwerbenden Warenposten stehen wir gern zur Verfügung. - Значения, касающиеся натуральных характеристик изделий и тестов, выполненных внешними авторизованными лабораториями, имеются в компании. Мы готовы выполнить проверку партии товара, которую намереваетесь приобрести.

*** Dato riferito al formato 60x60 cm. - Detail referred to the 60x60 cm size. - Donnée se rapportant au format 60x60 cm. - Auf die Formate 60x60 cm bezogen. - Значения, касающиеся натуральных характеристик изделий и тестов.

• Per prodotti chimici di uso domestico e additivi per piscina. - For domestic chemicals and swimming pool additives. - Pour produits chimiques à usage domestique et additifs pour piscines. - Für chemische Produkte für den Hausgebrauch und Schwimmbadzusätze. - Для бытовых химикатов и дробов для бассейнов.

▲ Valori wet DCOF specifici disponibili in azienda - Wet DCOF specific values available at the company - Valeurs wet DCOF spécifiques disponibles à l'usine - Prüfwerte Wet DCOF stehen im Werk zur Verfügung - Показатели wet DCOF доступны при запросе

Le tonalità dei campioni sono da considerarsi puramente indicative. - Tones of samples are indicative. - Les tonalités des échantillons sont purement indicatives. - Die farbtöne der Muster sind als rein indicativ zu betrachten. - Тона образцов ориентировочные.

Key_Mood

Shaping your project



Key_mood ha un aspetto sobrio, ricco di dettagli, ideale per progetti di architettura, di design, ma anche del vivere quotidiano. Il programma è completo, organico e ambizioso, con una palette colori classica sviluppata su un'ampia gamma di formati e finiture, per l'interno e per l'esterno. La collezione è caratterizzata da un pattern delicato, leggero, armonico, che dialoga con il sottotono di fondo dando vita a un look moderno, pregiato, in grado di rendere unici gli spazi che riveste.

Key_mood has an understated appearance that is packed with details, ideal for architecture and design projects, as well as for everyday living environments. The collection is comprehensive, organic and ambitious, with a classic colour palette spanning a broad range of sizes and finishes, for both indoor and outdoor use. The collection is distinguished by a delicate, light and harmonious pattern, which liaises with the background, giving rise to a modern, prized look, capable of making its surroundings truly unique.

Key-mood a un aspect sobre, riche en détails, idéal pour les projets d'architecture, de design, mais aussi de la vie quotidienne. Le projet est complet, organique et ambitieux, avec une palette de couleurs classique qui se développe sur une vaste gamme de formats et finitions, pour l'intérieur et pour l'extérieur. La collection se caractérise par un motif délicat, léger, harmonieux, qui dialogue avec la nuance de fond, en créant un look moderne, précieux, en mesure de rendre les espaces uniques.

Key_mood präsentiert sich elegant, reich an Details, ideal für Architektur- und Designprojekte, aber auch für das Ambiente, in dem wir uns täglich aufhalten. Das Programm ist vollständig, organisch und ambitioniert, mit einer klassischen Farbpalette und einer breiten Auswahl an Formaten und Oberflächen, für innen und außen. Die Kollektion zeichnet sich durch ein feines, leichtes und harmonisches Muster aus, das mit dem Grundton dialogiert und einen modernen, edlen Look erzeugt, der jeden Raum einzigartig macht.

Сдержанная и богатая деталями коллекция Key_mood идеально подходит не только для архитектурных и дизайнерских проектов, но и для повседневного интерьера. Линейка полностью укомплектована, органична и амбициозна. Она характеризуется классической палитрой цветов и широким ассортиментом форматов и поверхностей и подходит как для помещений, так и для улицы. Коллекцию характеризует легкий, деликатный и гармоничный узор, который переключается с фоном и дает жизнь роскошному современному дизайну, делая любой интерьер уникальным.



Info
Resources
Tools



STONE LOOK

Floor: SMOKE 120x120 MATT RT R10 B
Wall: HEXA-STRIPES COLORMIX 38x47 MATT, COTTON 60x120 SOFT RT

Colori - Formati

Colors - Sizes

120x120 . 60x120 . 60x60 . 30x60 9 mm MATT RT R10 B
 120x120 . 60x120 . 80x80 9 mm SOFT RT
 60x120 9 mm CRAFT MATT RT
 60x120 9 mm STRIPES MATT RT
 60x120 9 mm GRIP RT R11 C
 60x120 . 80x80 . 60x60 20 mm AEXTRA20 RT R11 C

COTTON

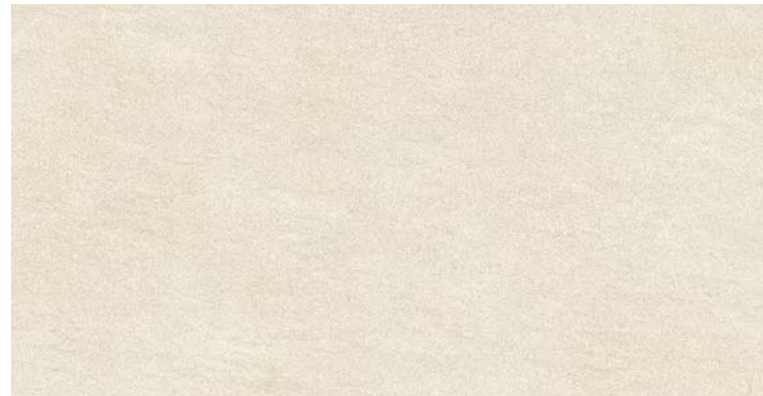

CANVAS



SMOKE



AIR



SHADE

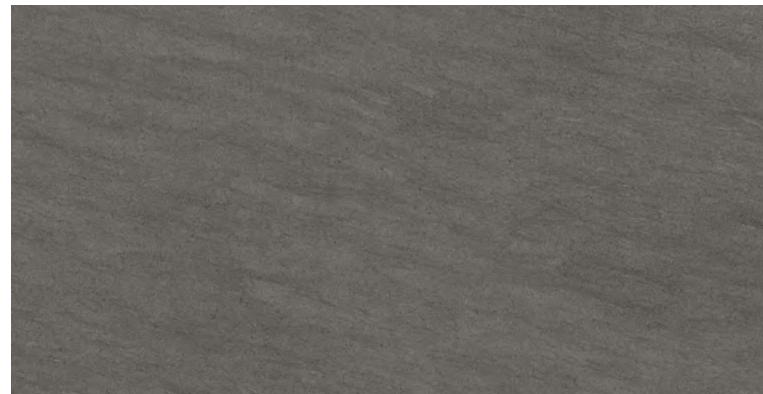

*La liste à jour des produits et formats des series certifiées QB-UPEC est disponible en usine.

9 mm

MATT RT R10 B

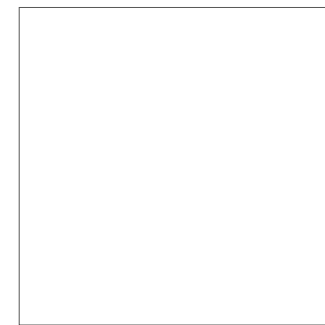

120x120
47²/₈"x47²/₈"



60x120
23⁵/₈"x47²/₈"



60x60
23⁵/₈"x23⁵/₈"



30x60
11¹⁵/₁₆"x23⁵/₈"

9 mm

SOFT RT

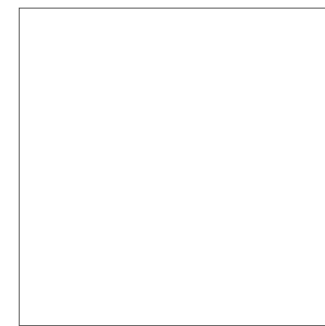

120x120
47²/₈"x47²/₈"



60x120
23⁵/₈"x47²/₈"

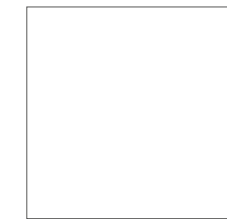

80x80
31¹/₈"x31¹/₈"

9 mm

CRAFT MATT RT



60x120
23⁵/₈"x47²/₈"

9 mm

STRIPES MATT RT



60x120
23⁵/₈"x47²/₈"

9 mm

GRIP RT R11 C



60x120
23⁵/₈"x47²/₈"

20 mm

AEXTRA20 RT R11 C



60x120
23⁵/₈"x47²/₈"

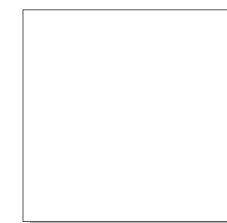

80x80
31¹/₈"x31¹/₈"

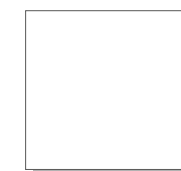































60x60
23⁵/₈"x23⁵/₈"

Key_Mood

STONE LOOK

La gamma

The range

| | COTTON | CANVAS | SMOKE  | AIR  | SHADE  |
|-------------------|-----------------------------------------------------------------------------------------------------------------------|-----------------------------------------------------------------------------------------------------------------------|-------------------------------------------------------------------------------------------------------------------------|-------------------------------------------------------------------------------------------------------------------------|-------------------------------------------------------------------------------------------------------------------------|
| MATT RT R10 B | 120x120 60x120 60x60 30x60  | 120x120 60x120 60x60 30x60  | 120x120 60x120 60x60 30x60  | 120x120 60x120 60x60 30x60  | 120x120 60x120 60x60 30x60  |
| SOFT RT | 120x120 60x120 80x80  | 120x120 60x120 80x80  | 120x120 60x120 80x80  | 120x120 60x120 80x80  | 120x120 60x120 80x80  |
| CRAFT MATT RT | 60x120  | | | | 60x120  |
| STRIPES MATT RT | 60x120  | 60x120  | 60x120  | 60x120  | 60x120  |
| GRIP RT R11 C | 60x120  | 60x120  | 60x120  | 60x120  | 60x120  |
| AEXTRA20 RT R11 C | 60x120 80x80  | 60x120 80x80 60x60  | 60x120 80x80 60x60  | 80x80  | 80x80  |



Key_Mood

STONE LOOK

Decori

Decors

COMPOSIZIONE M 30x30 cm . 11¹³/₁₆"x11¹³/₁₆" MATT

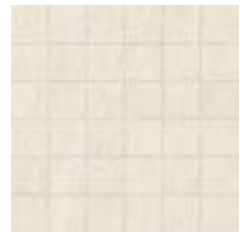

COTTON



CANVAS



SMOKE

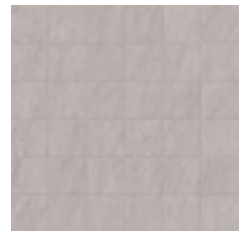

AIR



SHADE

HEXAGONS 30x30 cm . 11¹³/₁₆"x11¹³/₁₆" MATT



COTTON



CANVAS



SMOKE



AIR



SHADE

HEXA-STRIPES 38x47 cm . 14¹⁵/₁₆"x18¹/₂" MATT



COTTON



CANVAS



SMOKE



AIR



SHADE



COLORMIX



CARATTERISTICHE TECNICHE

TILE PERFORMANCE DATA - NOTES TECHNIQUES - TECHNISCHE AUSKÜNFTE - ТЕХНИЧЕСКАЯ ХАРАКТЕРИСТИКА

Classificazione secondo EN ISO 14411 ISO 13006 annesso G gruppo Bla con Ev ≤0,5% - Classification in accordance with EN ISO 14411 ISO 13006 annex G standards Bla with Ev ≤ 0,5% - Classification selon EN ISO 14411 ISO 13006 annexe G groupe Bla avec Ev ≤0,5% - Klassifizierung gemäß EN ISO 14411 ISO 13006 anlage G Gruppe Bla mit Ev ≤0,5% - Классификация в соответствии с EN ISO 14411 ISO 13006, приложение G, стандарт Bla, где Ev ≤0,5%

| | | |
|--|------------------------------------------------------------------------------------------------------------------------------------------------------------|--|
| |  120x120 cm $47\frac{7}{8} \times 47\frac{7}{8} \text{\"/> $ | |
|--|------------------------------------------------------------------------------------------------------------------------------------------------------------|--|















| | |
|--|-----------------------------------------------------------------------------------------------------------------------------------------------------------|
| |  60x120 cm $23\frac{5}{8} \times 47\frac{7}{8} \text{\"/> $ |
|--|-----------------------------------------------------------------------------------------------------------------------------------------------------------|

| IMBALLI - PACKAGING - CONDITIONNEMENT - VERPACKUNGS-EINHEITEN - УПАКОВКА | | | | | | | | |
|--------------------------------------------------------------------------|---------------------------------------|----|------------------------------------------|--------|----|---------------------------|-----------|--|
| Formato - Size - Format - Формат | | | Scatola - Box - Boîte - Karton - Коробка | | | Pallet - Palette - Палета | | |
| CM | INCHES | PZ | MQ | KG | SC | MQ | KG | |
| 120x120 | 47 $\frac{7}{8}$ x 47 $\frac{7}{8}$ " | 2 | 2,8561 | -62,00 | 20 | 57,122 | -1.240,00 | |
| 60x120 | 23 $\frac{5}{8}$ x 47 $\frac{7}{8}$ " | 2 | 1,44 | -30,40 | 35 | 50,40 | -1.064,00 | |
| 80x80 | 31 $\frac{1}{8}$ x 31 $\frac{1}{8}$ " | 2 | 1,28 | -27,36 | 48 | 61,44 | -1.313,28 | |
| 60x60 | 23 $\frac{5}{8}$ x 23 $\frac{5}{8}$ " | 4 | 1,44 | -28,40 | 30 | 43,20 | -852,00 | |
| 30x60 | 11 $\frac{3}{8}$ x 23 $\frac{5}{8}$ " | 7 | 1,26 | -25,00 | 40 | 50,40 | -1.000,00 | |
| 60x120 AEXTRA20 | 23 $\frac{5}{8}$ x 47 $\frac{7}{8}$ " | 1 | 0,72 | -33,35 | 35 | 25,20 | -1.167,25 | |
| 80x80 AEXTRA20 | 31 $\frac{1}{8}$ x 31 $\frac{1}{8}$ " | 1 | 0,64 | -29,70 | 42 | 26,88 | -1.247,40 | |
| 60x60 AEXTRA20 | 23 $\frac{5}{8}$ x 47 $\frac{7}{8}$ " | 2 | 0,72 | -32,00 | 30 | 21,60 | -960,00 | |

RT Rettificato, squadrato, monocalibro. - Rectified, squared, one caliber. - Rectifié, mis d'equerre et monocalibre. - Rektifiziert, rechteckig und Ein kaliber. - Ректифицированный, одного калибра.
 ** Disponibile solo su richiesta. - Manufactured only upon special request. - Seulement sur demande. - Nur auf Anfrage. - Производится только по заказу.

Si raccomanda l'utilizzo di una fuga di 2/3 mm al fine di semplificare le operazioni di posa e ottimizzare la naturalezza del risultato finale. - We recommend you a 2/3 mm grout joint to simplify the laying and optimize the naturalness of the final result. - Un joint de 2/3 mm est conseillé afin de simplifier les opérations de pose et optimiser l'effet naturel du résultat final. - Es wird empfohlen mit einer Fuge von 2/3 mm zu arbeiten, um am Ende den Verlegevorgang zu vereinfachen und die bestmögliche Natürlichkeit der Arbeit zu erzielen. - Для упрощения операций укладки и повышения натуральности вида конечного результата рекомендуется выполнять шов шириной 2-3 мм.

Al fine di facilitare la manutenzione ordinaria si raccomanda di effettuare un lavaggio acido dopo 48 ore dalla stuccatura con un acido specifico per grès porcellanato. - In order to favour the ordinary maintenance procedures, it is recommended to carry out an acid wash of the surface after 48 hours from grout filling using an acid agent specific for porcelain stoneware tiles. - Afin de faciliter l'entretien ordinaire de votre carrelage, nous vous conseillons de le laver 48 heures après le colmatage des joints, avec un acide spécifique pour grès cérame. - Um die Instandhaltung zu erleichtern, empfiehlt es sich 48 Stunden nach der Stuckatur mit einer sauren Lösung speziell für Feinsteinzeug zu waschen. - Чтобы упростить уход за плиткой, спустя 48 часов после затирки швов рекомендуется выполнить обработку кислотным продуктом, пригодным для керамигранита.

| CARATTERISTICA TECNICA TECHNICAL CHARACTERISTIC CARACTERISTIQUE TECHNIQUE TECHNISCHE DATEN ТЕХНИЧЕСКАЯ ХАРАКТЕРИСТИКА | METODO DI PROVA TESTS METHOD METHODE D'ESSAI TESTMETHODE МЕТОД ИСПЫТАНИЯ | VALORE * MEDIO "CAESAR" AVERAGE "CAESAR" VALUE* VALEUR * MOYEN "CAESAR" "CAESAR" DURCHSCHNITTSWERT* СРЕДНЕЕ ЗНАЧЕНИЕ "CAESAR"* | VALORE * MEDIO "CAESAR" AVERAGE "CAESAR" VALUE AEXTRA20 OPEN YOUR STYLE | | | | | | | | | | | | | | | | |
|------------------------------------------------------------------------------------------------------------------------------------------------------------------------------------------------------------------------------------------------------------------------------------------------------------------------|--------------------------------------------------------------------------------------|--------------------------------------------------------------------------------------------------------------------------------------------|------------------------------------------------------------------------------------------------------------------------------------------------------------------------------------------------------------------------------------------------------------------------------------------------------------------------------------------------------------------------------------------------------------------------------------------------------------------------------------------------------------------------------------------------|--|-------|-------|--------|--------------------------------------------------|--------|--------|--------|--------------------------------------------------------------------------------------|--------|--------|--------|----------------------------------------------------------------|--------|--------|--------|
|  Dimensione - Size Dimension - Abmessungen - Размер | ISO 10545-2 | Conforme - In accordance Conforme - Erfüllt - Соответствует | Conforme - In accordance Conforme - Erfüllt - Соответствует | | | | | | | | | | | | | | | | |
|  Assorbimento d'acqua* - Water absorption* Absorption d'eau* - Wasseraufnahme* - % Поглощения воды* | ISO 10545-3 | ≤ 0,1% | ≤ 0,1% | | | | | | | | | | | | | | | | |
|  Resistenza alla flessione* - Bending strength* Résistance à la flexion* - Biegezugfestigkeit* - Упругость* | ISO 10545-4 | Conforme - In accordance Conforme - Erfüllt - Соответствует | Non applicabile a piastrelle con una forza di rottura ≥ 3000 N Not applicable to tiles with a breaking strenght ≥ 3000 N N'est pas applicable aux carreaux avec une charge de rupture ≥ 3000 N Nicht anwendbar bei Fliesen mit einer Bruchlast ≥ 3000 N Не применяется в отношении плиток с прочности на азрыв ≥ 3000 N | | | | | | | | | | | | | | | | |
|  Sforzo di rottura (S) - Breaking strength Charge de rupture - Bruchlast - разрушающее усилие | ISO 10545-4 | Sps ≥ 7,5 mm S ≥ 1300 N | > 10.000 N | | | | | | | | | | | | | | | | |
|  Resistenza all'abrasione profonda* - Deep scratch resistance* Résistance à l'abrasion profonde* - Widerstand gegen Tiefenverschleiß* Устойчивость глубокому истиранию* | ISO 10545-6 | Conforme - In accordance Conforme - Erfüllt - Соответствует | Conforme - In accordance Conforme - Erfüllt - Соответствует | | | | | | | | | | | | | | | | |
|  Coefficiente di dilatazione termica lineare* - Thermal linear expansion coefficient* Coefficient de dilatation thermique linéaire - Koeffizient der linearen thermischen Dehnung* - Коэффициент линейного теплового расширения* | ISO 10545-8 | ≈ 7 (10 ⁻⁶ °C ⁻¹) | ≈ 7 (10 ⁻⁶ °C ⁻¹) | | | | | | | | | | | | | | | | |
|  Resistenza agli sbalzi termici* - Thermal shock resistance* Résistance aux écarts de température* - Temperaturwechsel Beständigkeit* Устойчивость к тепловому перепаду* | ISO 10545-9 | Resistente - Resistant Résistante - Beständig - Стойкий | Resistente - Resistant Résistante - Beständig - Стойкий | | | | | | | | | | | | | | | | |
|  Dilatazione all'umidità* - Expansion in humidity* Dilatation à l'umidité* - Feuchtigkeitsausdehnung* Расширение в условиях влажности* | ISO 10545-10 | ≤ 0,1 (mm/m) | ≤ 0,1 (mm/m) | | | | | | | | | | | | | | | | |
|  Resistenza al gelo* - Frost resistance* Résistance au gel* - Frostbeständigkeit* - Морозоустойчивость* | ISO 10545-12 | Resistente - Resistant Résistante - Beständig - Стойкий | Resistente - Resistant Résistante - Beständig - Стойкий | | | | | | | | | | | | | | | | |
|  Resistenza all'attacco chimico* - Resistance to chemical attack* Résistance à l'attaque chimique* - Beständigkeit gegen Chemikalien* Устойчивость к химическому воздействию* | ISO 10545-13 | Resistente - Resistant Résistante - Beständig - Стойкий | Resistente - Resistant Résistante - Beständig - Стойкий | | | | | | | | | | | | | | | | |
|  Carico statico - Static load Charge statique - Statische Last Статическая нагрузка | EN 12825 | - | <table border="1"> <tr> <td></td> <td>60x60</td> <td>80x80</td> <td>60x120</td> </tr> <tr> <td>Centro - Centre Au centre - Mitte - По центру</td> <td>KN>7,0</td> <td>KN>7,0</td> <td>KN>5,0</td> </tr> <tr> <td>Centro lato - Side centre Au centre latéralement - Mitte Seite По центру грани</td> <td>KN>5,0</td> <td>KN>5,0</td> <td>KN>4,0</td> </tr> <tr> <td>Diagonale - Diagonal - En diagonale Diagonal - По диагонали</td> <td>KN>8,0</td> <td>KN>8,0</td> <td>KN>7,0</td> </tr> </table> | | 60x60 | 80x80 | 60x120 | Centro - Centre Au centre - Mitte - По центру | KN>7,0 | KN>7,0 | KN>5,0 | Centro lato - Side centre Au centre latéralement - Mitte Seite По центру грани | KN>5,0 | KN>5,0 | KN>4,0 | Diagonale - Diagonal - En diagonale Diagonal - По диагонали | KN>8,0 | KN>8,0 | KN>7,0 |
| | 60x60 | 80x80 | 60x120 | | | | | | | | | | | | | | | | |
| Centro - Centre Au centre - Mitte - По центру | KN>7,0 | KN>7,0 | KN>5,0 | | | | | | | | | | | | | | | | |
| Centro lato - Side centre Au centre latéralement - Mitte Seite По центру грани | KN>5,0 | KN>5,0 | KN>4,0 | | | | | | | | | | | | | | | | |
| Diagonale - Diagonal - En diagonale Diagonal - По диагонали | KN>8,0 | KN>8,0 | KN>7,0 | | | | | | | | | | | | | | | | |
|  Classe di carico di rottura*** - Breaking load class*** Classe de charge de rupture*** - Bruchlastklasse*** Класс стойкости к разрушающей нагрузке*** | EN 1339 | - | U11 T11 | | | | | | | | | | | | | | | | |
|  Resistenza alle macchie* - Resistance to stains* Résistance aux taches* - Fleckenbeständigkeit* Устойчивость к образованию пятен* | ISO 10545-14 | Pulibile - Cleanable Nettoyable - Leicht zu reinigen Чистящийся | Pulibile - Cleanable Nettoyable - Leicht zu reinigen Чистящийся | | | | | | | | | | | | | | | | |
|  Resistenza allo scivolamento** - Slip resistance** Résistance au glissement** - Rutschhemmende Eigenschaft** Сопротивление скольжению** | DIN 51130 - DIN 51097 ▲ ANSI A326.3 | R10 B Matt - Soft R11 C Grip | Wet DCOF ≥ 0,42 Wet DCOF ≥ 0,42 Wet DCOF ≥ 0,55 | | | | | | | | | | | | | | | | |
|  Spessore nominale - Nominal Thickness Epaisseur nominal - Nominalstärke Номинальная толщина | | 9 mm | 20 mm | | | | | | | | | | | | | | | | |

* Valori medi riferiti agli ultimi due anni di produzione e relativi alla finitura naturale del prodotto - Average values referred to the last two years of production and related to the matt finish of the product - Valeurs moyennes des deux dernières années de production et relatifs à la finition naturelle du produit - Durchschnittswerte, die sich auf die letzten zwei Produktionsjahre beziehen und auf die matte Oberfläche - Средние значения относятся к последним двум годам производства и натуральной отделке поверхности

** Valori relativi alla finitura naturale del prodotto ed a test effettuati da laboratori esterni accreditati, disponibili in azienda; ci rendiamo disponibili alla verifica dell'eventuale lotto interessato all'acquisto. - As far as values relating to the matt finish of the product and to tests carried out by certified external laboratories whose results are available upon request at Headoffice, we are willing to check the lot you are interested in purchasing. - Valeurs se référant à la finition naturelle du produit selon des tests effectués par des laboratoires extérieurs accrédités et à la disposition de toute personne intéressée auprès de nos bureaux; nous sommes disponibles pour le contrôle de l'éventuel lot concerné par l'achat. - Werte bezogen auf das natürliche Produktfinish und in anerkannten externen Labors geprüft, im Unternehmen erhältlich; für eventuelle Prüfungen der zu erwerbenden Warenposten stehen wir gern zur Verfügung. - Означения, касающиеся натуральных характеристик изделий и тестов, выполненных внешними авторизованными лабораториями, имеются в компании. Мы готовы выполнить проверку партии товара, которую наммереваетесь приобрести.

*** Dato riferito al formato 60x60 cm. - Detail referred to the 60x60 cm size. - Donnée se rapportant au format 60x60 cm. - Auf die Formate 60x60 cm bezogen. - Означения, касающиеся натуральных характеристик изделий и тестов.

• Per prodotti chimici di uso domestico e additivi per piscina. - For domestic chemicals and swimming pool additives. - Pour produits chimiques à usage domestique et additifs pour piscines. - Für chemische Produkte für den Hausgebrauch und Schwimmbadzusätze. - Для бытовых химикатов и добавок для бассейнов.

▲ Valori wet DCOF specifici disponibili in azienda - Wet DCOF specific values available at the company - Valeurs wet DCOF spécifiques disponibles à l'usine - Prüfwerte Wet DCOF stehen im Werk zur Verfügung - Показатели wet DCOF доступны при запросе

Le tonalità dei campioni sono da considerarsi puramente indicative. - Tones of samples are indicative. - Les tonalités des échantillons sont purement indicatives.
Die farbtöne der Muster sind als rein indicativ zu betrachten. - Тона образцов ориентировочные.

Portraits

Collection of beauties



Portraits è una collezione in grès porcellanato che nasce al termine di un viaggio alla scoperta di 6 pietre tanto diverse nei modi di essere e presentarsi, quanto affini per la bellezza istintiva e la straordinaria forza d'animo.

Portraits is a collection in porcelain stoneware developed at the end of a journey of discovery into 6 stones that are uniquely different in their way of being and their look, but that all share a common, instinctive beauty and extraordinary strength of spirit.

Portraits est une collection en grès cérame qui a vu le jour à la fin d'un voyage à la découverte de 6 pierres à l'aspect très différent mais qui ont en commun une beauté naturelle et une forte personnalité.

Die Feinsteinzeug Kollektion Portraits entsteht aus einer Reise rund um 6 Natursteine, die so unterschiedlich in ihrer Art und Erscheinung sind, wie ihre unmittelbare Schönheit und Ausdruckskraft sie verbindet.

Рождение керамогранитной коллекции Portraits подобно путешествию, помогшему познать 6 изумительных камней, разных по характеру и виду, но схожих по инстинктивной красоте и силе духа.



Info
Resources
Tools



STONE LOOK

Portraits



STONE LOOK

Colori - Formati

Colors - Sizes

160x320 . 120x278 6 mm MATT RT
 120x120 . 60x120 . 30x120 . 60x60 . 30x60 9 mm MATT RT
 60x60 . 30x60 9 mm HONED RT
 60x60 9 mm TEXTURED RT R11 C
 60x120 . 60x90 . 60x60 20 mm AEXTRA20 RT R11 C

COMBLANCHIEN



FARO



TOZEUR



VERSILIA



KIRKBY



STROMBOLI



6 mm

MATT RT

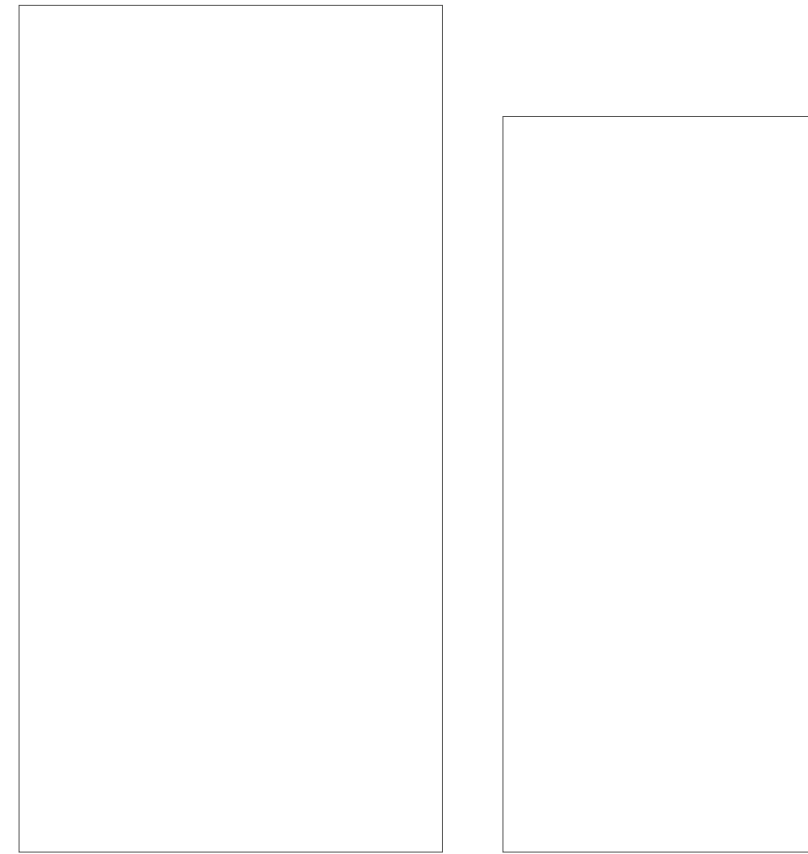

160x320
63"x126"

120x278
47²/₈"x109⁷/₁₆"

9 mm

MATT RT

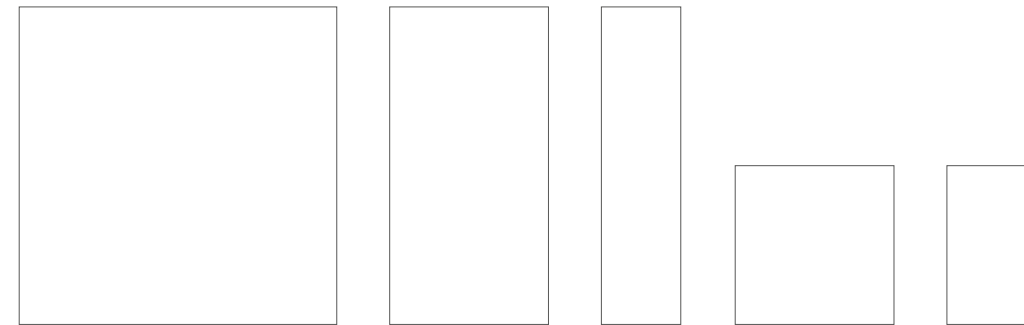

120x120
47²/₈"x47²/₈"

60x120
23⁵/₈"x47²/₈"

30x120
11⁵/₁₆"x47²/₈"

60x60
23⁵/₈"x23⁵/₈"

30x60
11⁵/₁₆"x23⁵/₈"

9 mm

HONED RT



60x60
23⁵/₈"x23⁵/₈"

30x60
11⁵/₁₆"x23⁵/₈"

20 mm

AEXTRA20 RT R11 C

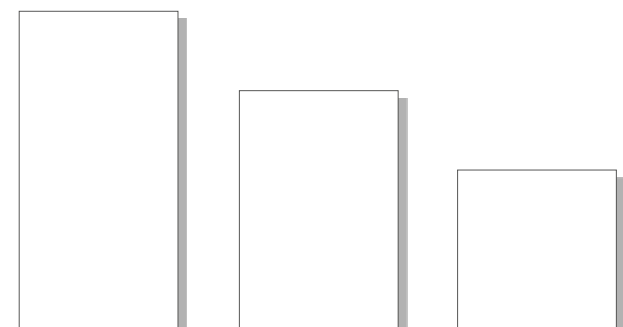

60x120
23⁵/₈"x47²/₈"

60x90
23⁵/₈"x35⁷/₁₆"

60x60
23⁵/₈"x23⁵/₈"

9 mm

TEXTURED RT R11 C



60x60
23⁵/₈"x23⁵/₈"

Portraits

STONE LOOK

La gamma

The range

COMBLANCHIEN

FARO

TOZEUR

VERSILIA



KIRKBY



STROMBOLI



MATT RT

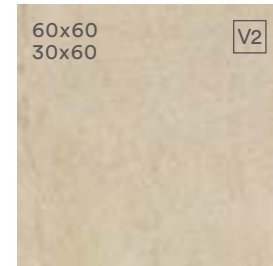
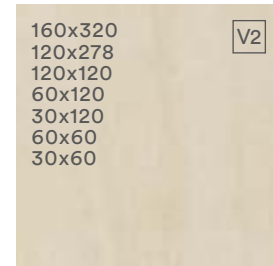
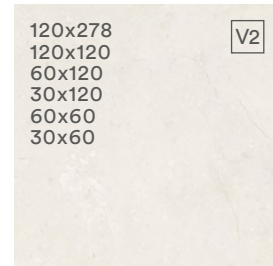

HONED RT



TEXTURED RT R11 C



AEXTRA20 RT R11 C

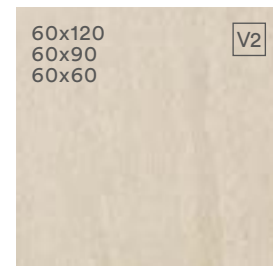

RT Rettificato, squadrato, monocalibro. - Rectified, squared, one caliber. - Rectifié, mis d'équerre et monocalibre. - Rektifiziert, rechtwinkelig und Ein kaliber. - Ректифицированный, одного калибра.

Portraits

STONE LOOK

Decori

Decors

COMPOSIZIONE M 30x30 cm . 11¹³/₁₆"x11¹³/₁₆" MATT

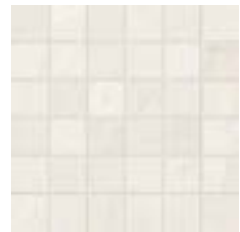

COMBLANCHIEN



FARO

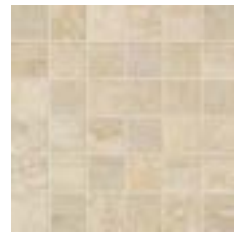

TOZEUR



VERSILIA



KIRKBY

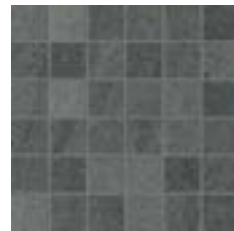

STROMBOLI

WALL MIX 30x60 cm . 11¹³/₁₆"x23⁵/₈" MATT+TEXTURED



COMBLANCHIEN



FARO

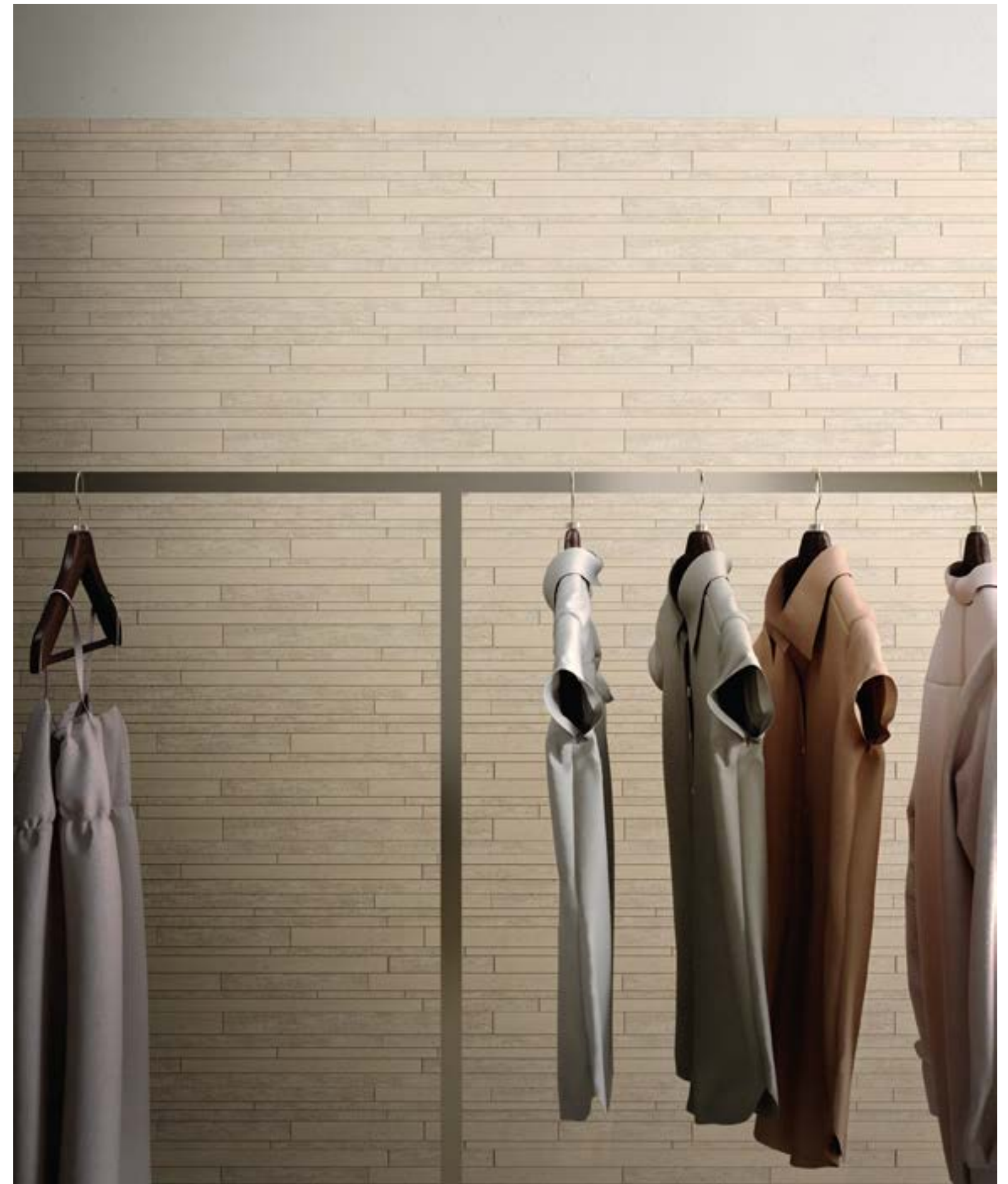

CARATTERISTICHE TECNICHE

TILE PERFORMANCE DATA - NOTES TECHNIQUES - TECHNISCHE AUSKÜNFTTE - ТЕХНИЧЕСКАЯ ХАРАКТЕРИСТИКА

Classificazione secondo EN ISO 14411 ISO 13006 annesso G gruppo B1a con Ev ≤0,5% - Classification in accordance with EN ISO 14411 ISO 13006 annex G standards B1a with Ev ≤ 0,5% - Classification selon EN ISO 14411 ISO 13006 annexe G groupe B1a avec Ev ≤0,5% - Klassifizierung gemäß EN ISO 14411 ISO 13006 anlage G Gruppe B1a mit Ev ≤0,5% - Классификация в соответствии с EN ISO 14411 ISO 13006, приложение G, стандарт B1a, где Ev ≤0,5%

| | 160x320 cm 63"x126" 6 mm MATT RT | 120x278 cm 47 1/8"x109 1/16" 6 mm MATT RT | 120x120 cm 47 1/8"x47 1/8" 9 mm MATT RT | 60x120 cm 23 5/8"x47 1/8" 9 mm MATT RT | 30x120 cm 11 9/16"x47 1/8" 9 mm MATT RT | 60x60 cm 23 5/8"x23 5/8" 9 mm TEXTURED RT R11 C | HONED RT | 30x60 cm 11 9/16"x23 5/8" 9 mm MATT RT | HONED RT |
|--------------|--------------------------------------------------|-----------------------------------------------------------|---------------------------------------------------------|--------------------------------------------------------|---------------------------------------------------------|-----------------------------------------------------------------|-----------------|--------------------------------------------------------|-----------------|
| Comblanchien | • | • | • | • | • | • | • | • | • |
| Faro | • | • | • | • | • | • | • | • | • |
| Tozeur | • | • | • | • | • | • | • | • | • |
| Versilia | • | • | • | • | • | • | • | • | • |
| Kirkby | • | • | • | • | • | • | • | • | • |
| Stromboli | • | • | • | • | • | • | • | • | • |

| | 60x120 cm 23 5/8"x47 1/8" 20 mm RT R11 C | 60x90 cm 23 5/8"x35 1/16" 20 mm RT R11 C | 60x60 cm 23 5/8"x23 5/8" 20 mm RT R11 C | 7,2x60 cm 2 13/16"x23 5/8" MATT | 33x120 cm 13"x47 1/8" MATT | 33x60 cm 13"x23 5/8" MATT | 33x33 cm 13"x13" MATT |
|--------------|----------------------------------------------------------|----------------------------------------------------------|---------------------------------------------------------|----------------------------------------------|-----------------------------------------|----------------------------------------|------------------------------------|
| Comblanchien | • | • | • | • | • | • | • |
| Faro | • | • | • | • | • | • | • |
| Versilia | • | • | • | • | • | • | • |
| Kirkby | • | • | • | • | • | • | • |















| | 7,2x60 cm 2 13/16"x23 5/8" MATT | 33x120 cm 13"x47 1/8" MATT | 33x60 cm 13"x23 5/8" MATT | 33x33 cm 13"x13" MATT |
|--------------|----------------------------------------------|-----------------------------------------|----------------------------------------|------------------------------------|
| Comblanchien | • | • | • | • |
| Faro | • | • | • | • |
| Tozeur | • | • | • | • |
| Versilia | • | • | • | • |
| Kirkby | • | • | • | • |
| Stromboli | • | • | • | • |

| IMBALLI - PACKAGING - CONDITIONNEMENT - VERPACKUNGS-EINHEITEN - УПАКОВКА | | | | | | | | |
|--------------------------------------------------------------------------|-------------------|------------------------------------------|--------|--------|---------------------------|-------|----------|--|
| Formato - Size - Format - Формат | | Scatola - Box - Boîte - Karton - Коробка | | | Pallet - Palette - Палета | | | |
| CM | INCHES | PZ | MQ | KG | SC | MQ | KG | |
| 160x320 | 63"x126" | 1 | 5,12 | ~78,00 | 14 | 71,68 | ~1092,00 | |
| 120x278 | 47 1/8"x109 1/16" | 1 | 3,3221 | ~49,56 | 18 | 59,79 | ~892,08 | |
| 120x120 | 47 1/8"x47 1/8" | 2 | 2,856 | ~62,00 | 20 | 57,12 | ~1240,00 | |
| 60x120 | 23 5/8"x47 1/8" | 2 | 1,44 | ~30,40 | 35 | 50,40 | ~1064,00 | |
| 30x120 | 11 9/16"x47 1/8" | 4 | 1,44 | ~30,40 | 16 | 23,04 | ~486,40 | |
| 60x60 | 23 5/8"x23 5/8" | 4 | 1,44 | ~28,40 | 30 | 43,20 | ~852,00 | |
| 60x60 HONED | 23 5/8"x23 5/8" | 3 | 1,08 | ~22,80 | 40 | 43,20 | ~912,00 | |
| 30x60 MATT | 11 9/16"x23 5/8" | 7 | 1,26 | ~25,00 | 40 | 50,40 | ~1000,00 | |
| 30x60 HONED | 11 9/16"x23 5/8" | 6 | 1,08 | ~22,98 | 40 | 43,20 | ~919,20 | |
| 60x120 AEXTRA 20 | 23 5/8"x47 1/8" | 1 | 0,72 | ~33,35 | 35 | 25,20 | ~1167,25 | |
| 60x90 AEXTRA 20 | 23 5/8"x35 1/16" | 2 | 1,08 | ~48,50 | 24 | 25,92 | ~1164,00 | |
| 60x60 AEXTRA 20 | 23 5/8"x23 5/8" | 2 | 0,72 | ~32,00 | 30 | 21,60 | ~960,00 | |

RT Rettificato, squadrato, monocallibro. - Rectified, squared, one calibre. - Rectifié, mis d'equerre et monocallibre. - Rektifiziert, rechteckig und Ein kaliber. - Ректифицированный, одного калибра.
 ** Disponibile solo su richiesta. - Manufactured only upon special request. - Seulement sur demande. - Nur auf Anfrage. - Производится только по заказу.

Si raccomanda l'utilizzo di una fuga di 2/3 mm al fine di semplificare le operazioni di posa e ottimizzare la naturalezza del risultato finale. - We recommend you a 2/3 mm grout joint to simplify the laying and optimize the naturalness of the final result. - Un joint de 2/3 mm est conseillé afin de simplifier les opérations de pose et optimiser l'effet naturel du résultat final. - Es wird empfohlen mit einer Fuge von 2/3 mm zu arbeiten, um am Ende den Verlegungsvorgang zu vereinfachen und die bestmögliche Natürlichkeit der Arbeit zu erzielen. - Для упрощения операций укладки и повышения натуральности вида конечного результата рекомендуется выполнять швы шириной 2-3 мм.

Al fine di facilitare la manutenzione ordinaria si raccomanda di effettuare un lavaggio acido dopo 48 ore dalla stuccatura con un acido specifico per grès porcellanato. - In order to favour the ordinary maintenance procedures, it is recommended to carry out an acid wash of the surface after 48 hours from grout filling using an acid agent specific for porcelain stoneware tiles. - Afin de faciliter l'entretien ordinaire de votre carrelage, nous vous conseillons de le laver 48 heures après le colmatage des joints, avec un acide spécifique pour grès cérame. - Um die Instandhaltung zu erleichtern, empfiehlt es sich 48 Stunden nach der Stuckatur mit einer sauren Lösung speziell für Feinsteinzeug zu waschen. - Чтобы упростить уход за плиткой, спустя 48 часов после затирки швов рекомендуется выполнить обработку кислотным продуктом, пригодным для керамогранита.

| | CARATTERISTICA TECNICA TECHNICAL CHARACTERISTIC CARACTERISTIQUE TECHNIQUE TECHNISCHE DATEN ТЕХНИЧЕСКАЯ ХАРАКТЕРИСТИКА | METODO DI PROVA TESTS METHOD METHODE D'ESSAI TESTMETHODE МЕТОД ИСПЫТАНИЯ | VALORE * MEDIO "CAESAR" AVERAGE "CAESAR" VALUE * VALEUR * MOYEN "CAESAR" "CAESAR" DURCHSCHNITTSWERT * СРЕДНЕЕ ЗНАЧЕНИЕ "CAESAR" * | VALORE * MEDIO "CAESAR" AVERAGE "CAESAR" VALUE A E X T R A 2 0 OPEN YOUR STYLE | | | | | | | | | | | | | | | | |
|---------------------------------------------------------------------------------------|------------------------------------------------------------------------------------------------------------------------------------------------------------------------------------------------------------------------------------|--------------------------------------------------------------------------------------|-----------------------------------------------------------------------------------------------------------------------------------------------|--------------------------------------------------------------------------------------------------------------------------------------------------------------------------------------------------------------------------------------------------------------------------------------------------------------------------------------------------------------------------------------------------------------------------------------------------------------------------------------------------------------------|--|-------|-------|--------|-------------------------------------------------|--------|--------|--------|------------------------------------------------------------------------------------|--------|--------|--------|---------------------------------------------------------------|--------|--------|--------|
|  | Dimensione - Size Dimension - Abmessungen - Размер | ISO 10545-2 | Conforme - In accordance Conforme - Erfüllt - Соответствует | Conforme - In accordance Conforme - Erfüllt - Соответствует | | | | | | | | | | | | | | | | |
|  | Assorbimento d'acqua* - Water absorption* Absorption d'eau* - Wasseraufnahme* - % Поглощения воды* | ISO 10545-3 | ≤ 0,1% | ≤ 0,1% | | | | | | | | | | | | | | | | |
|  | Resistenza alla flessione* - Bending strength* Résistance à la flexion* - Biegezugfestigkeit* - Упругость* | ISO 10545-4 | Conforme - In accordance Conforme - Erfüllt - Соответствует | Non applicabile a piastrelle con una forza di rottura ≥ 3000 N Not applicable to tiles with a breaking strength ≥ 3000 N Nicht applicable aux carreaux avec une charge de rupture ≥ 3000 N Nicht anwendbar bei Fliesen mit einer Bruchlast ≥ 3000 N Не применяется в отношении плиток с прочностью на изрыв ≥ 3000 N | | | | | | | | | | | | | | | | |
|  | Sforzo di rottura (S) - Breaking strength Charge de rupture - Bruchlast - разрушающее усилие | ISO 10545-4 | Sps ≥ 7,5 mm S ≥ 1300 N | > 10.000 N | | | | | | | | | | | | | | | | |
|  | Resistenza all'abrasione profonda* - Deep scratch resistance* Résistance à l'abrasion profonde* - Widerstand gegen Tiefenverschleiß* Устойчивость к глубокому истиранию* | ISO 10545-6 | Conforme - In accordance Conforme - Erfüllt - Соответствует | Conforme - In accordance Conforme - Erfüllt - Соответствует | | | | | | | | | | | | | | | | |
|  | Coefficiente di dilatazione termica lineare* - Thermal linear expansion coefficient* Coefficient de dilatation thermique linéaire - Koeffizient der linearen thermischen Dehnung* - Коэффициент линейного теплового расширения* | ISO 10545-8 | ≈ 7 (10 ⁻⁶ °C ⁻¹) | ≈ 7 (10 ⁻⁶ °C ⁻¹) | | | | | | | | | | | | | | | | |
|  | Resistenza agli sbalzi termici* - Thermal shock resistance* Résistance aux écarts de température* - Temperaturwechsel Beständigkeit* Устойчивость к тепловому перепаду* | ISO 10545-9 | Resistente - Resistant Résistante - Beständig - Стойкий | Resistente - Resistant Résistante - Beständig - Стойкий | | | | | | | | | | | | | | | | |
|  | Dilatazione all'umidità* - Expansion in humidity* Dilatation à l'humidité* - Feuchtigkeitsausdehnung* Расширение в условиях влажности* | ISO 10545-10 | ≤ 0,1 (mm/m) | ≤ 0,1 (mm/m) | | | | | | | | | | | | | | | | |
|  | Resistenza al gelo* - Frost resistance* Résistance au gel* - Frostbeständigkeit* - Морозостойкость* | ISO 10545-12 | Resistente - Resistant Résistante - Beständig - Стойкий | Resistente - Resistant Résistante - Beständig - Стойкий | | | | | | | | | | | | | | | | |
|  | Resistenza all'attacco chimico - Resistance to chemical attack - Résistance à l'attaque chimique - Beständigkeit gegen Chemikalien - Устойчивость к химическому воздействию - | ISO 10545-13 | Resistente - Resistant Résistante - Beständig - Стойкий | Resistente - Resistant Résistante - Beständig - Стойкий | | | | | | | | | | | | | | | | |
|  | Carico statico - Static load Charge statique - Statische Last Статическая нагрузка | EN 12825 | - | <table border="1"> <tr><td></td><td>60x60</td><td>60x90</td><td>60x120</td></tr> <tr><td>Centro - Centre - Au centre - Mitte - По центру</td><td>KN>7,0</td><td>KN>8,0</td><td>KN>5,0</td></tr> <tr><td>Centro lato - Side centre - Au centre latéralement - Mitte Seite - По центру грани</td><td>KN>5,0</td><td>KN>6,0</td><td>KN>4,0</td></tr> <tr><td>Diagonale - Diagonal - En diagonale - Diagonal - По диагонали</td><td>KN>8,0</td><td>KN>8,0</td><td>KN>7,0</td></tr> </table> | | 60x60 | 60x90 | 60x120 | Centro - Centre - Au centre - Mitte - По центру | KN>7,0 | KN>8,0 | KN>5,0 | Centro lato - Side centre - Au centre latéralement - Mitte Seite - По центру грани | KN>5,0 | KN>6,0 | KN>4,0 | Diagonale - Diagonal - En diagonale - Diagonal - По диагонали | KN>8,0 | KN>8,0 | KN>7,0 |
| | 60x60 | 60x90 | 60x120 | | | | | | | | | | | | | | | | | |
| Centro - Centre - Au centre - Mitte - По центру | KN>7,0 | KN>8,0 | KN>5,0 | | | | | | | | | | | | | | | | | |
| Centro lato - Side centre - Au centre latéralement - Mitte Seite - По центру грани | KN>5,0 | KN>6,0 | KN>4,0 | | | | | | | | | | | | | | | | | |
| Diagonale - Diagonal - En diagonale - Diagonal - По диагонали | KN>8,0 | KN>8,0 | KN>7,0 | | | | | | | | | | | | | | | | | |
|  | Classe di carico di rottura*** - Breaking load class*** Classe de charge de rupture*** - Bruchlastklasse*** Класс стойкости к разрушающей нагрузке*** | EN 1339 | - | U11 T11 | | | | | | | | | | | | | | | | |
|  | Resistenza alle macchie* - Resistance to stains* Résistance aux taches* - Fleckenbeständigkeit* Устойчивость к образованию пятен* | ISO 10545-14 | Pulibile - Cleanable Nettoyable - Leicht zu reinigen Чистящийся | Pulibile - Cleanable Nettoyable - Leicht zu reinigen Чистящийся | | | | | | | | | | | | | | | | |
|  | Resistenza allo scivolamento** - Slip resistance** Résistance au glissement** - Rutschhemmende Eigenschaft** Сопротивление скольжению** | DIN 51130 - DIN 51097 | R9 Matt Rt1 C Textured - Honed | R11 C Wet DCOF ≥ 0,55 | | | | | | | | | | | | | | | | |
|  | Spessore nominale - Nominal Thickness Epaisseur nominale - Nominalstärke Номинальная толщина | | 6 mm 160x320 - 120x278 9 mm 120x120 - 60x120 - 30x120 60x60 - 30x60 | 20 mm | | | | | | | | | | | | | | | | |

* Valori medi riferiti agli ultimi due anni di produzione e relativi alla finitura naturale del prodotto - Average values referred to the last two years of production and related to the matt finish of the product - Valeurs moyennes des deux dernières années de production et relatifs à la finition naturelle du produit - Durchschnittswerte, die sich auf die letzten zwei Produktionsjahre beziehen und auf die matte Oberfläche - Средние значения относятся к последним двум годам производства и натуральной отделке поверхности

** Valori relativi alla finitura naturale del prodotto ed a test effettuati da laboratori esterni accreditati, disponibili in azienda; ci rendiamo disponibili alla verifica dell'eventuale lotto interessato all'acquisto. - As far as values relating to the matt finish of the product and to tests carried out by certified external laboratories whose results are available upon request at Headoffice, we are willing to check the lot you are interested in purchasing. - Valeurs se référant à la finition naturelle du produit selon des tests effectués par des laboratoires extérieurs accrédités et à la disposition de toute personne intéressée après de nos bureaux; nous sommes disponibles pour le contrôle de l'éventuel lot concerné par l'achat. - Werte bezogen auf das natürliche Produktfinish und in anerkannten externen Labors geprüft, im Unternehmen erhältlich; für eventuelle Prüfungen der zu erwerbenden Warenposten stehen wir gern zur Verfügung. - Значения, касающиеся натуральных характеристик изделий и тестов, выполненных внешними авторизованными лабораториями, имеются в компании. Мы готовы выполнить проверку партии товара, которую намереваетесь приобрести.

*** Dato riferito al formato 60x60 cm. - Detail referred to the 60x60 cm size. - Donnée se rapportant au format 60x60 cm. - Auf die Formate 60x60 cm bezogen. - Значения, касающиеся натуральных характеристик изделий и тестов.

Per prodotti chimici di uso domestico e additivi per piscina. - For domestic chemicals and swimming pool additives. - Pour produits chimiques à usage domestique et additifs pour piscines. - Für chemische Produkte für den Hausgebrauch und Schwimmbadzusätze. - Для бытовых химикатов и добавок для бассейнов.

▲ Valori wet DCOF specifici disponibili in azienda - Wet DCOF specific values available at the company - Valeurs wet DCOF spécifiques disponibles à l'usine - Prüfwerte Wet DCOF stehen im Werk zur Verfügung - Показатели wet DCOF доступны при запросе

Le tonalità dei campioni sono da considerarsi puramente indicative. - Tones of samples are indicative. - Les tonalités des échantillons sont purement indicatives. - Die farbtoöne der Muster sind als rein indicativ zu betrachten. - Тона образцов ориентировочные.

Quartz Essence

Nature, inside and out



La bellezza delle migliori quarziti alpine trova nuova linfa in un'interpretazione in chiave contemporanea in grès: Quartz Essence scopre le molteplici sfaccettature della pietra naturale incontaminata. Una collezione che fa della versatilità il suo punto di forza, trovando sempre la migliore risposta progettuale dal suo ampio ventaglio di soluzioni per spazi indoor e outdoor.

The beauty of the finest alpine quartzites is given a new lease on life in a stoneware interpretation with a contemporary twist: Quartz Essence uncovers the myriad facets of uncontaminated natural stone. A collection underpinned by versatility, which always finds the best design concept to suit individual requirements thanks to its extensive array of solutions for both indoor and outdoor settings.

La beauté des meilleurs quartzites alpins trouve une nouvelle saveur dans une interprétation contemporaine en grès: Quartz Essence dévoile les nombreuses facettes de la pierre naturelle immaculée. Une collection qui fait de la polyvalence son point fort, en trouvant toujours la meilleure réponse conceptuelle grâce à son large éventail de solutions pour espaces intérieurs et extérieur.

Die ganze Schönheit der hochwertigsten Quarzite aus den Alpen in einer zeitgemäßen Feinsteinzeug- Interpretation: Quartz Essence besticht mit den vielfältigen Facetten des ursprünglichen Natursteins. Eine Kollektion, die mit ihrer Vielseitigkeit überzeugt und mit ihrem breiten Sortiment die perfekte Lösung für jeden Innen- und Außenbereich bietet.

Красота лучших альпийских кварцитов обретает новую жизнь в керамограните, интерпретированном в современном ключе: Quartz Essence представляет многогранность натурального камня без примесей. Коллекция, которая делает универсальность своей сильной стороной и всегда предлагает лучший вариант для дизайнерского проекта из широкого спектра решений для внутренних и наружных пространств.



Info
Resources
Tools



Floor: (IN) NEST 60x120 MATT RT R10 B, (OUT) NEST 60x120 GRIP RT R11 C
Wall: NEST 60x120 MATT RT R10 B, WILD 30x60 MATT RT R10 B, WILD COMPOSIZIONE M 30x30 MATT

Quartz Essence

STONE LOOK

Colori - Formati

Colors - Sizes

60x120 . 60x60 . 40x60 . 30x60 . 20x60 . 10x60 . 30x30 9 mm MATT RT R10 B

60x120 . 60x60 9 mm GRIP RT R11 C

30x60 8 mm OUT NR R11 C

60x120 . 60x90 . 80x80 . 60x60 20 mm AEXTRA20 RT R11 C

FLAKE



NEST



ROCKY



BURNT



WILD



9 mm MATT RT R10 B

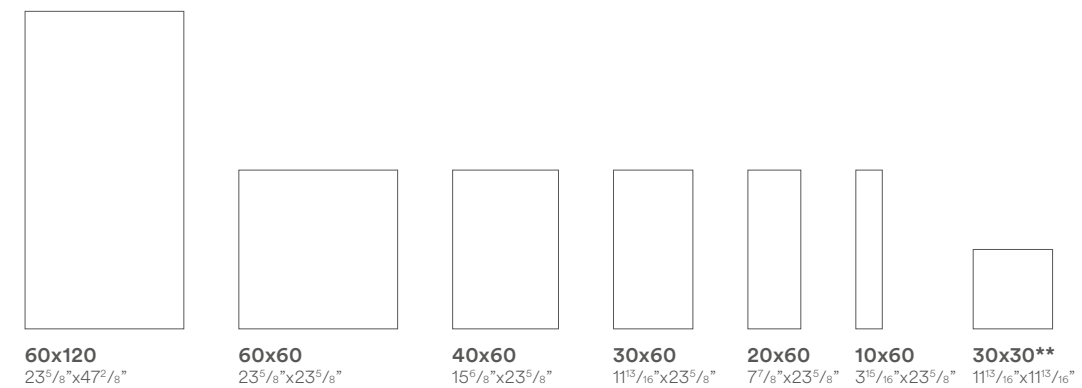

9 mm GRIP RT R11 C

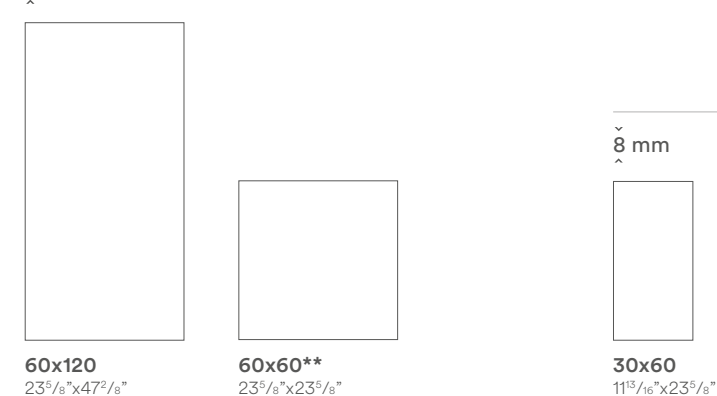

20 mm AEXTRA20 RT R11 C

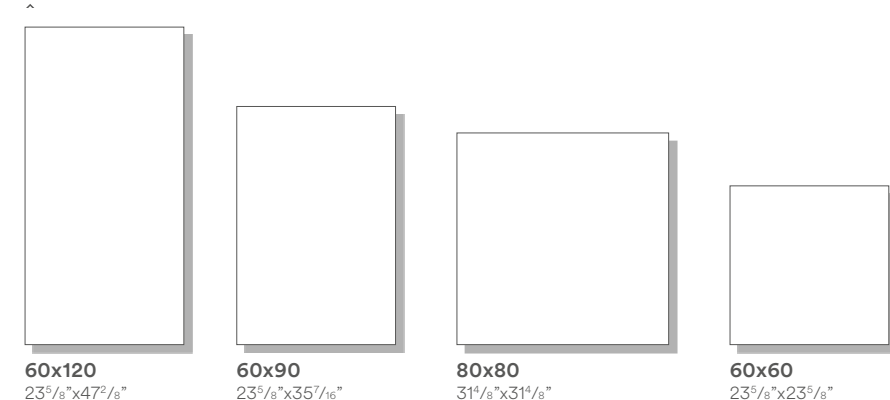







** Disponibile solo su richiesta. - Manufactured only upon special request. - Seulement sur demande. - Nur auf Anfrage. - Производится только по заказу.

Quartz Essence

STONE LOOK

La gamma

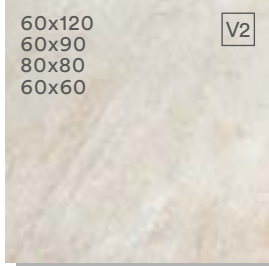
The range

| | FLAKE | NEST | ROCKY  | BURNT  | WILD  |
|-------------------|---------------------------------------------------------------------------------------------------------------------------------------------------------------|---------------------------------------------------------------------------------------------------------------------------------------------------------------|----------------------------------------------------------------------------------------------------------------------------------------------------------------|-----------------------------------------------------------------------------------------------------------------------------------------------------------------|------------------------------------------------------------------------------------------------------------------------------------------------------|
| MATT RT R10 B |  <p>60x120 60x60 40x60 30x60 20x60 10x60 30x30 A</p> |  <p>60x120 60x60 40x60 30x60 20x60 10x60 30x30 A</p> |  <p>60x120 60x60 40x60 30x60 20x60 10x60 30x30 A</p> |  <p>60x120 60x60 40x60 30x60 20x60 10x60 30x30 A</p> |  <p>60x60 40x60 30x60 20x60 10x60 30x30 A</p> |
| GRIP RT R11 C |  <p>60x120 60x60 A</p> |  <p>60x120 60x60 A</p> |  <p>60x120 60x60 A</p> |  <p>60x120 60x60 A</p> | |
| OUT NR R11 C |  <p>30x60</p> |  <p>30x60</p> |  <p>30x60</p> |  <p>30x60</p> | |
| AEXTRA20 RT R11 C |  <p>60x120 60x90 80x80 60x60</p> |  <p>60x120 60x90 80x80 60x60</p> |  <p>60x120 60x90 80x80 60x60</p> |  <p>60x120 60x90 80x80 60x60</p> |  <p>60x120 60x90 80x80 60x60</p> |

Decori

Decors

COMPOSIZIONE M 30x30 cm . 11¹⁵/₁₆"x11¹⁵/₁₆" MATT



FLAKE



NEST



ROCKY



BURNT

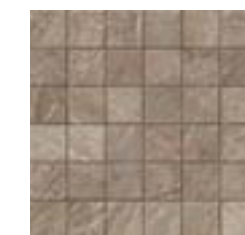

WILD

COMPOSIZIONE P 29,5x39 cm . 11⁵/₈"x15³/₈" MATT



FLAKE



NEST



ROCKY



BURNT



WILD

A: Disponibile solo su richiesta. - Manufactured only upon special request. - Seulement sur demande. - Nur auf Anfrage. - Производится только по заказу.

RT Rettificato, squadrato, monocalibro. - Rectified, squared, one caliber. - Rectifié, mis d'équerre et monocalibre. - Rektifiziert, rechteckig und Ein kaliber. - Ректифицированный, одного калибра.

NR Non rettificato. - Not rectified. - Non rectifié. - Nicht rektifiziert. - Не ретицированный.

Quartz Essence



Aextra modular design

Sulla gamma Quartz Essence Aextra20 Caesar propone quattro moduli multiformato, sfruttando le misure in gamma e introducendo due formati -30x60 e 30x30- dedicati a questo impiego.

On Quartz Essence Aextra20 range, Caesar offers four multiple size modules, exploiting the dimensions in the range and introducing two cutting sizes - 30x60 and 30x30 - dedicated to this particular usage.

Dans la gamme Quartz Essence Aextra20, Caesar propose quatre modules multi-formats, en exploitant les mesures et en ajoutant deux formats de coupe, 30x60 et 30x30, consacrés à cet usage.

Im Quartz Essence Aextra20-Sortiment bietet Caesar vier verschiedene, mehrformatige Module, die sich aus den bereits vorhandenen Formaten sowie zwei neuen, eigens für diese Verlegung eingeführten Schnittformaten 30x60 und 30x30 zusammensetzen.

В гамме Quartz Essence Aextra20 от Caesar представлены четыре мультиформатных модуля, использующих уже существующие форматы гаммы и включающих два новых формата 30x60 и 30x30, созданных специально в этих целях.

KIT MODULO / KIT MODULE: 1

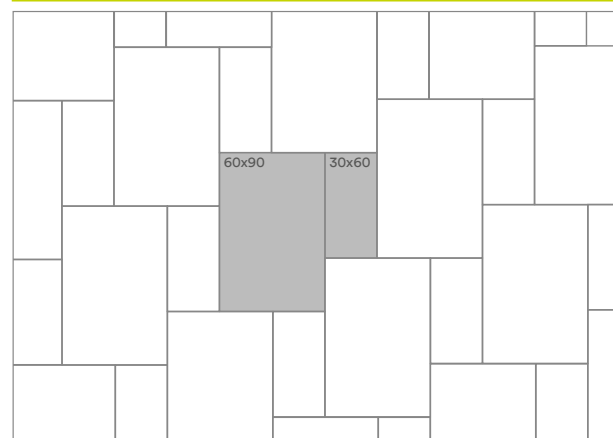

| Formato / Size | Scatole per kit / Boxes for each kit | Pezzi/ Pcs. | Mq/ Sqm. | Kg |
|-----------------------|--------------------------------------|-------------|----------|--------------|
| 60x90 cm | 1 | 2 | 1,08 | ~48,5 |
| 30x60 cm | 1 | 2 | 0,36 | ~16 |
| TOTALE / TOTAL | | 1,44 | | ~66,5 |

KIT MODULO / KIT MODULE: 2

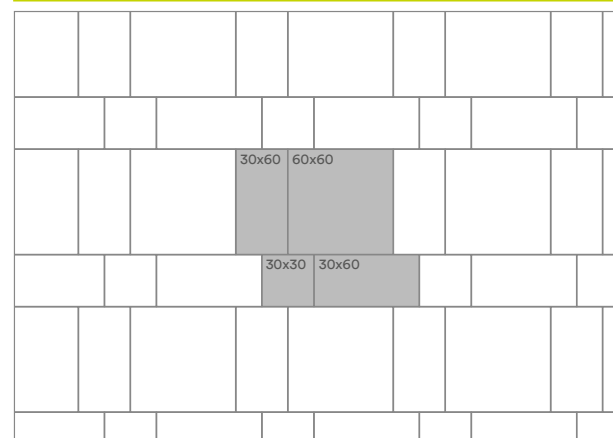

| Formato / Size | Scatole per kit / Boxes for each kit | Pezzi/ Pcs. | Mq/ Sqm. | Kg |
|-----------------------|--------------------------------------|-------------|----------|-------------|
| 60x90 cm | 2 | 4 | 1,44 | ~64 |
| 30x60 cm | 4 | 8 | 1,44 | ~64 |
| 30x30 cm | 1 | 4 | 0,36 | ~16 |
| TOTALE / TOTAL | | 3,24 | | ~144 |

KIT MODULO / KIT MODULE: 3

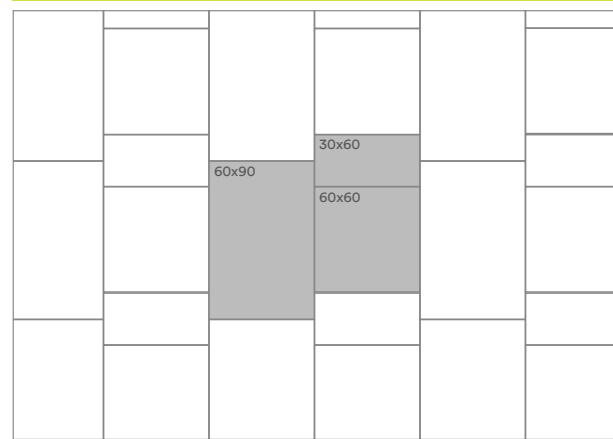

| Formato / Size | Scatole per kit / Boxes for each kit | Pezzi/ Pcs. | Mq/ Sqm. | Kg |
|-----------------------|--------------------------------------|-------------|----------|-------------|
| 60x90 cm | 2 | 4 | 2,16 | ~97 |
| 60x60 cm | 2 | 4 | 1,44 | ~64 |
| 30x60 cm | 1 | 4 | 0,72 | ~16 |
| TOTALE / TOTAL | | 4,32 | | ~177 |

KIT MODULO / KIT MODULE: 4

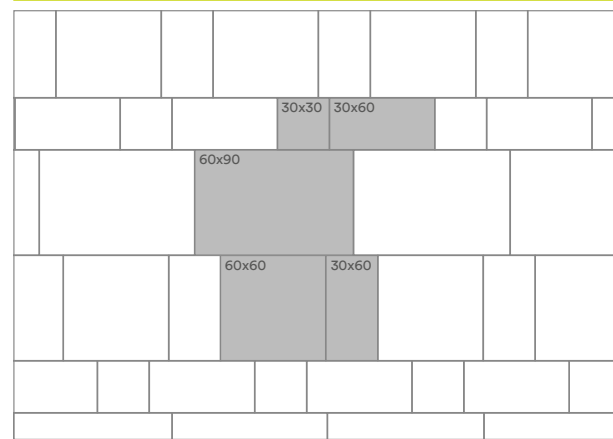

| Formato / Size | Scatole per kit / Boxes for each kit | Pezzi/ Pcs. | Mq/ Sqm. | Kg |
|-----------------------|--------------------------------------|-------------|----------|-------------|
| 60x90 cm | 2 | 4 | 2,16 | ~97 |
| 60x60 cm | 2 | 4 | 1,44 | ~64 |
| 30x60 cm | 4 | 8 | 1,44 | ~64 |
| 30x30 cm | 1 | 4 | 0,36 | ~16 |
| TOTALE / TOTAL | | 5,40 | | ~241 |



STONE LOOK

Floor: **ROCKY KIT MODULE 4 AEXTRA20 RT R11 C**
Furniture by CLOS: **ALCHEMY NAVY**

Fuga consigliata. - Recommenden joint. - Joint conseillé. - Empfohlene Fuge. - Рекомендуемый шов. : 4 mm

AEXTRA 20

60x90
23⁵/₈"x35⁷/₁₆"



60x60
23⁵/₈"x23⁵/₈"



30x60 **
11³/₁₆"x23⁵/₈"



30x30 **
11³/₁₆"x11³/₁₆"



**** Formati disponibili esclusivamente nell'ambito delle pose modulari. These sizes are only available within multi-size layouts.**

Le pose multiformato "Aextra Modular Design" si possono effettuare solamente con la modalità di posa incollata. Sono escluse le tipologie di posa sopraelevata e a secco. / "Aextra Modular Design" multi-size layouts can be only installed on floors with adhesives. The raised and dry installation methods are excluded. / Les poses multiformats "Aextra Modular Design" ne peuvent être réalisées qu'avec une pose collée. Les autres types de pose, surélevée et à sec, sont exclus. / Die Modulverlegung "Aextra Modular Design" ist ausschließlich in gebundener Bauweise möglich. Ausgeschlossen sind Verlegung auf Stelzlager und Trockenverlegung.

La variabilità di toni all'interno dello stesso modulo è da ritenersi una caratteristica intrinseca di questa tipologia di offerta, per enfatizzare la naturalezza del prodotto. Per ulteriori dettagli e le modalità di ordinazione, si prega di consultare il listino prezzi Quartz Essence.

The variability of tones within the same module should be deemed an intrinsic feature of this type of offering, to emphasise the naturalness of the product. For further details and for info about orders, please see Quartz Essence price list.

La variabilité des tons au sein d'un même module est une caractéristique intrinsèque de ce type de proposition, afin de souligner le caractère naturel du produit. Pour plus de détails et comment commander, veuillez consulter la liste de prix Quartz Essence.

Die Variabilität der Farbtöne innerhalb der Module selbst ist beabsichtigt und unterstreicht die Natürlichkeit des Produkts. Weitere Informationen und Bestellinformationen finden Sie in der Preisliste für Quarzessenzen.

Разнообразие оттенков в рамках одного модуля является неотъемлемой характеристикой этого предложения, подчеркивающего естественный вид изделия. Для получения дополнительной информации и того, как сделать заказ, обратитесь к прайс-листу Quartz Essence.

Shapes of Italy

A new italian renaissance



L'Italia è un Paese unico al mondo, di una bellezza assoluta, trasmessa attraverso materiali di grande fascino. "Shapes of Italy" si ispira a sette pietre naturali che hanno fatto la storia dell'arte e dell'architettura italiana e, grazie al design innovativo delle sue lastre ceramiche, conferisce un'eleganza contemporanea agli spazi dell'abitare.

Italy is a unique country in the world, one of absolute beauty, conveyed through its very attractive materials. "Shapes of Italy" is inspired by seven natural stones that have characterised the history of Italian art and architecture. Thanks to the innovative design of its ceramic slabs, the collection brings a contemporary elegance to living spaces.

L'Italie est un pays unique au monde, d'une beauté absolue, transmise à travers des matériaux d'un grand charme. « Shapes of Italy » s'inspire de sept pierres naturelles qui ont fait l'histoire de l'art et de l'architecture italienne et, grâce au design innovant de ses dalles céramiques, elle apporte une élégance contemporaine aux espaces d'habitation.

Italien ist ein in der ganzen Welt einzigartiges Land von einer absoluten Schönheit, die durch faszinierende Materialien vermittelt wird. "Shapes of Italy" ist an sieben Natursteinen inspiriert, die die Geschichte der Kunst und der italienischen Architektur geschrieben haben. Mit dem innovativen Design in ihrer keramischen Variante schenken Sie jedem Wohnraum zeitgenössische Eleganz.

Италия – уникальная страна в мире, славящаяся абсолютной красотой, которая находит отражение в материалах большой эстетики. Вдохновением коллекции «Shapes of Italy» стали семь натуральных камней, которые вошли в историю итальянского искусства и архитектуры и благодаря инновационному дизайну керамических плит, придают жилым пространствам современную элегантность.



Info
Resources
Tools

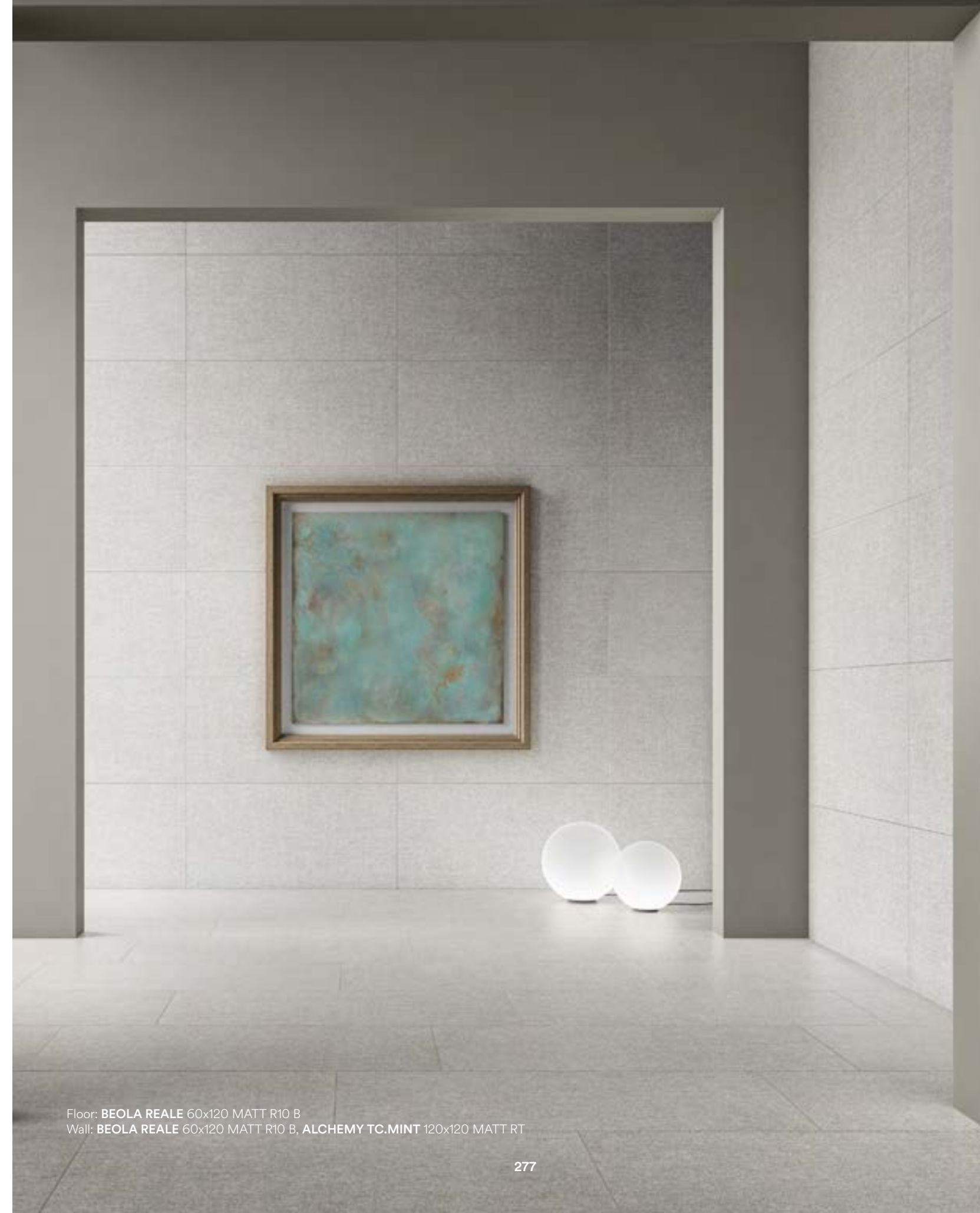

Floor: BEOLA REALE 60x120 MATT R10 B
Wall: BEOLA REALE 60x120 MATT R10 B, ALCHEMY TC.MINT 120x120 MATT RT

Shapes of Italy



STONE LOOK

Colori - Formati

Colors - Sizes

120x278 6 mm MATT RT
 120x120 . 60x120 . 80x80 . 60x60 . 40x60 . 30x60 . 20x60 . 10x60 9 mm MATT RT R10 B
 60x120 9 mm GRIP RT R11 C
 30x60 8 mm TEXTURED NR R11 C
 22,5x45,3 . 22,5x22,5 9 mm TEXTURED NR R11 C
 120x120 . 60x120 . 80x80 . 60x60 20 mm AEXTRA20 RT R11 C

BEOLA REALE



ITRIA



MONVISO



SESTRIERE



IULIA



LAVIS



GARDENA

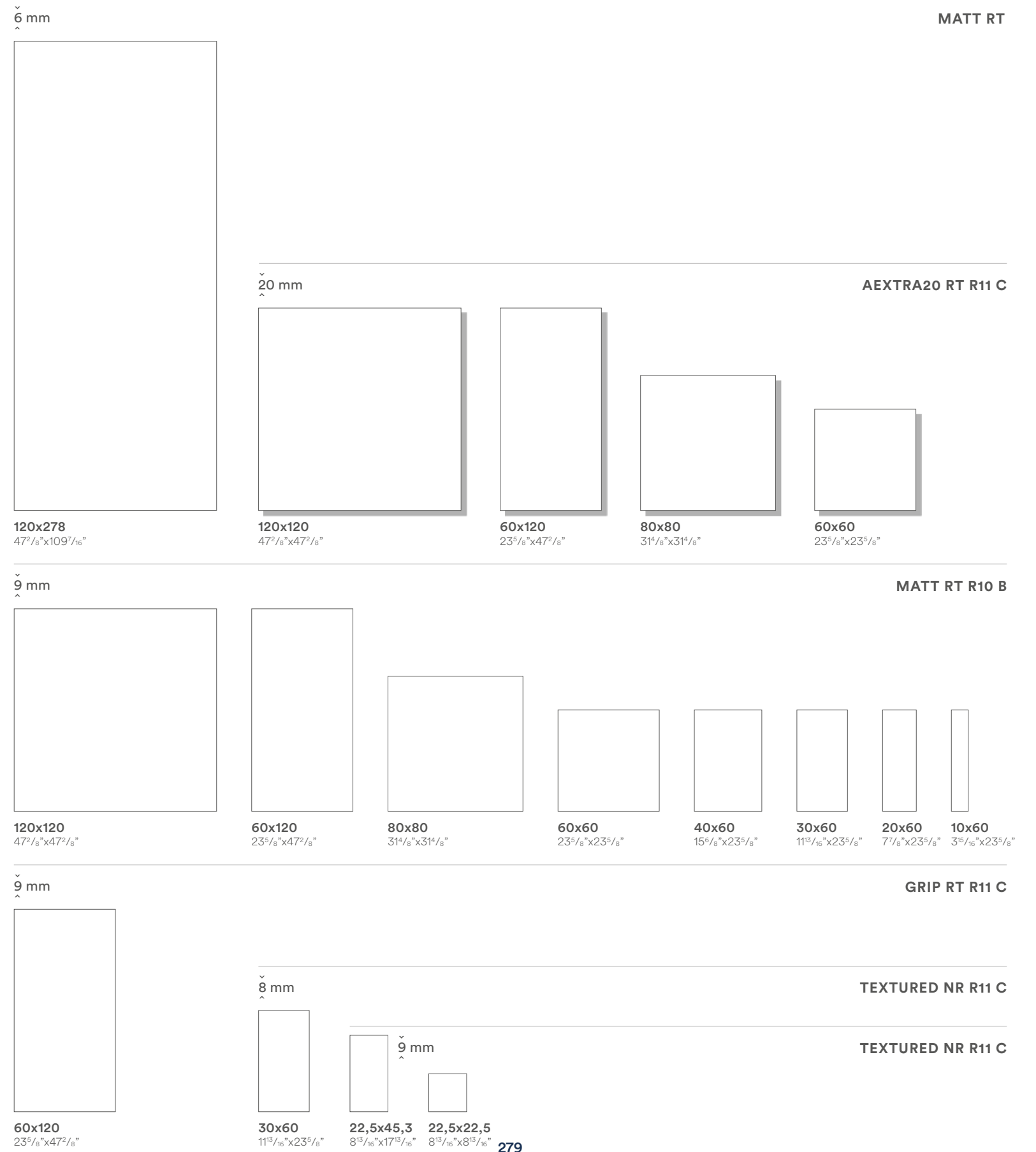
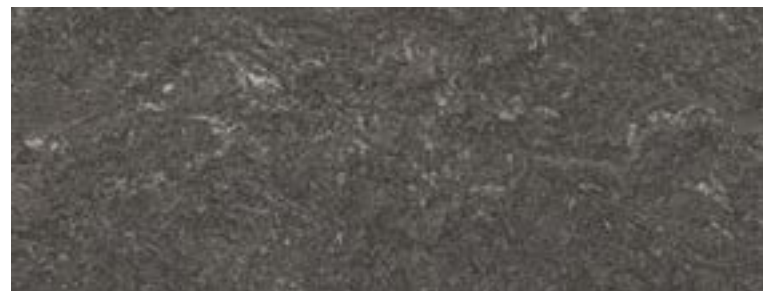

*La liste à jour des produits et formats des series certifiées QB-UPEC est disponible en usine.

Shapes of Italy

STONE LOOK

La gamma

The range

BEOLA REALE

ITRIA

MONVISO



SESTRIERE



IULIA



LAVIS



GARDENA



MATT RT



Iulia e Lavis in finitura naturale R10 B e strutturata R11 C hanno un aspetto e un tono differente, in quanto le lavorazioni a cui si ispirano sono diverse. Levigatura per la prima e fiammatura per la seconda.

Iulia and Lavis with a R10 B natural finish or R11 C textured finish differ in look and tone, as they are inspired by different techniques, polishing in the case of the first and bush-hammering for the second.

MATT RT R10 B

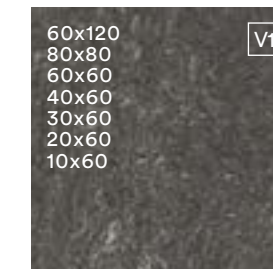
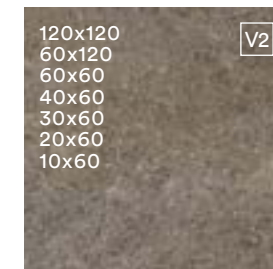
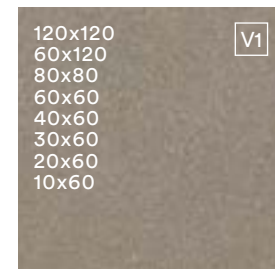
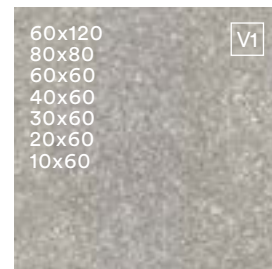
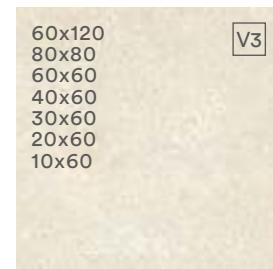
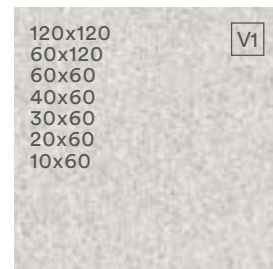

Iulia et Lavis en finition naturelle R10 B et structurée R11 C ont un aspect et une teinte différents dans la mesure où les procédés dont ils s'inspirent sont différents. Polissage pour la première et flammage pour la seconde.

Iulia und Lavis sind in Optik und Farbton in der natürlichen Oberfläche R10 B und in der strukturierten R11 C Oberfläche verschieden, da die Inspiration dafür die zwei unterschiedlichen Original Natursteinoberflächen sind, d.h. einmal die geschliffene und einmal die geflammte Version

GRIP RT R11 C

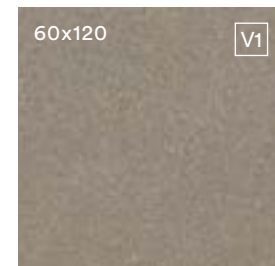

Iulia и Lavis, в натуральной отделке R10 B и в структурированной отделке R11 C отличаются внешним видом и тоном, поскольку были вдохновлены разными видами обработки материала. В первом случае речь идет о полировке, во втором – об обжиге для придания блеска.

TEXTURED NR R11 C

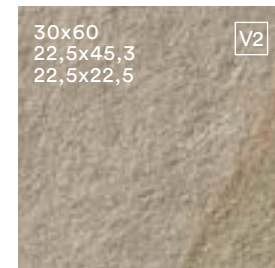
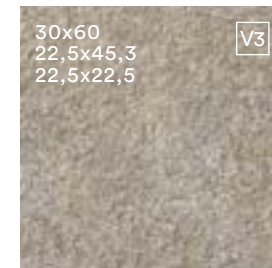
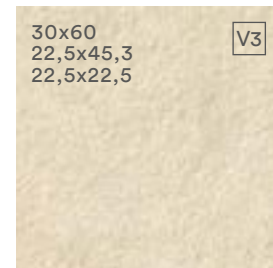

AEXTRA20 RT R11 C

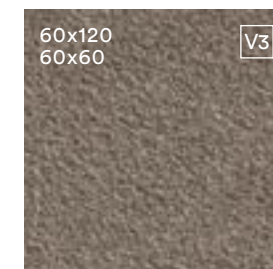
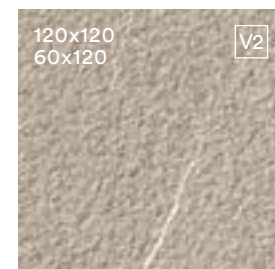
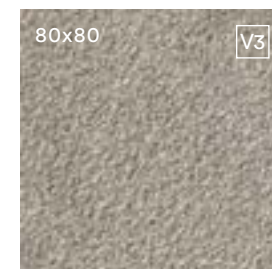
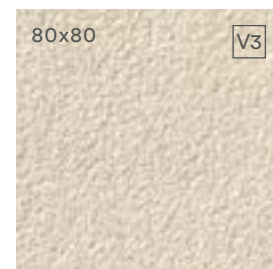

RT Rettificato, quadrato, monocalibro. - Rectified, squared, one caliber. - Rectifié, mis d'équerre et monocalibre. - Rektifiziert, rechteckig und Ein kaliber. - Ректифицированный, одного калибра.
NR Non rettificato. - Not rectified. - Non rectifié. - Nicht rektifiziert. - Не ретицированный.

Shapes of Italy

STONE LOOK

Decori

Decors

RILIEVO 15x60 cm . 5⁷/₈"x23⁵/₈" MATT



BEOLA REALE



ITRIA



SESTRIERE



IULIA



LAVIS



GARDENA

TRAMA 30x30 cm . 11¹³/₁₆"x11¹³/₁₆" MATT

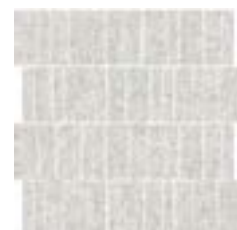

BEOLA REALE



ITRIA



SESTRIERE



IULIA

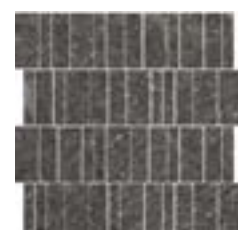

GARDENA

STELO OTTONE 0,5x60 cm . 3³/₁₆"x23⁵/₈" *

* Solo per rivestimento. - Only for wall application. - Exclusivement pour revêtement mural. - Nur als Wandverkleidung geeignet. - Только для облицовки.

VENTAGLIO 53,2x102,8 cm . 20¹⁵/₁₆"x40⁴/₈" TEXTURED



MONVISO



LAVIS



Caesar Contract Solutions

Caesar Contract Solutions è un insieme di collezioni che integrano l'ampia offerta di piastrelle in grès porcellanato di Ceramiche Caesar.

Caesar Contract Solutions is a set of collections that complement the wide range of porcelain tiles from Ceramiche Caesar.

L'ensemble des collections Caesar Contract Solutions permet d'intégrer la vaste gamme de carreaux en grès cérame de Ceramiche Caesar.

Caesar Contract Solutions ist ein Programm, das aus unterschiedlichen Kollektionen besteht und ergänzt das Feinsteinzeug Angebot von Ceramiche Caesar.

Caesar Contract Solutions - это набор коллекций, которые дополняют обширное предложение керамогранитной плитки компании Ceramiche Caesar.



Caesar Contract Solutions

The collections



Pillar

CCS



Con la serie Pillar il grès porcellanato di ultima generazione diventa protagonista indiscusso delle superfici contemporanee: ispirandosi alle pietre sedimentarie, ne supera i limiti in termini di resistenza e assorbimento. Pillar interpreta ed esalta le calde tonalità dei tipici limestones francesi, da sempre apprezzati per la loro versatilità ed equilibrio estetico, garantendo al contempo igiene e durata nel tempo a pavimenti e rivestimenti interni, in ambiti sia residenziali sia commerciali.

With the Pillar series, the latest generation of porcelain stoneware becomes the undisputed protagonist of contemporary surfaces: inspired by sedimentary stones, it overcomes their limits in terms of resistance and absorption. Pillar interprets and enhances the warm tones of the typical French limestones, always appreciated for their versatility and aesthetic balance, while ensuring hygiene and durability to both residential and commercial indoor floors and walls.

Avec la série Pillar, le grès cérame de dernière génération devient le protagoniste incontestable des surfaces contemporaines : s'inspirant des pierres sédimentaires, il en dépasse toutefois les limites de résistance et d'absorption. Pillar interprète et rehausse les tons chauds des calcaires français, appréciés depuis toujours pour leur polyvalence et leur équilibre esthétique, tout en garantissant hygiène et durée dans le temps aux revêtements de sol et muraux intérieurs, aussi bien dans des espaces résidentiels que commerciaux.

Mit der Serie Pillar setzt das Feinsteinzeug der neuesten Generation ganz neue Maßstäbe für zeitgemäße Oberflächen: Es ist an Sedimentgesteinen inspiriert, überwindet jedoch deren Grenzen in Sachen Beständigkeit und Wasseraufnahme. Pillar interpretiert und akzentuiert die warmen Farben der charakteristischen französischen Kalksteine, die seit jeher wegen ihrer Vielseitigkeit und harmonischen Optik beliebt sind. Zugleich garantiert es Hygiene und Langlebigkeit interner Boden- und Wandbeläge, im Wohnungs- wie im Gewerbebau.

В серии Pillar керамогранит последнего поколения становится главным героем современных поверхностей: вдохновленный осадочными камнями, Pillar превосходит их в том, что касается прочности и впитываемости. Серия Pillar воплощает в себе и усиливает теплые тона, типичные для французских известняков, которые всегда ценились за их универсальность и эстетическую сбалансированность, обеспечивая при этом гигиеничность и долговечность напольных и настенных покрытий как в жилых, так и в коммерческих помещениях.



Floor: **TAUPE** 60x120 MATT RT R10 B
Wall: **WHITE** 60x120 MATT RT R10 B, **TAUPE COMP M** 30x30 MATT



Info
Resources
Tools

Colori - Formati

Colors - Sizes

60x120 9 mm MATT RT R10 B
60x60 . 30x60 8 mm MATT RT R10 B

WHITE



TAUPE



SAND



GREIGE



9 mm



60x120
23⁵/₈"x47²/₈"

MATT RT R10 B

8 mm



60x60
23⁵/₈"x23⁵/₈"



30x60
11³/₁₆"x23⁵/₈"

MATT RT R10 B

*La liste a jour des produits et formats des series certifiees QB-UPEC est disponible en usine.

Pillar

La gamma

The range

WHITE

TAUPE



SAND

GREIGE



MATT RT R10 B

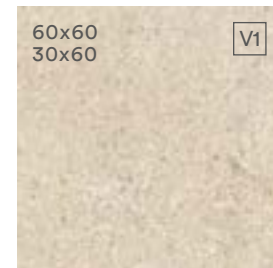
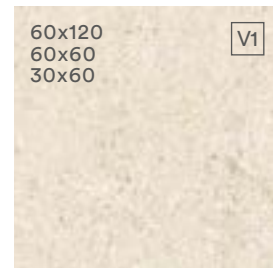

Decori

Decors

COMPOSIZIONE M 30x30 cm . 11¹³/₁₆"x11¹³/₁₆" MATT

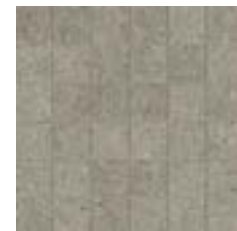
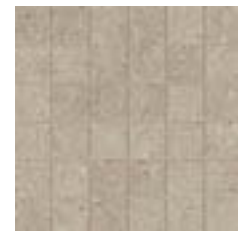
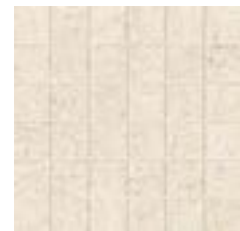

WHITE

TAUPE

SAND





GREIGE

RT Rettificato, squadrato, monocalibro. - Rectified, squared, one caliber. - Rectifié, mis d'équerre et monocalibre. - Rektifiziert, rechtwinkelig und Ein kaliber. - Ректифицированный, одного калибра.



Wall: TAUPE 60x60 MATT RT R10 B



| |  60x120 cm 23 ⁵ / ₁₆ "x47 ⁷ / ₁₆ " 9 mm MATT RT R10 B |  60x60 cm 23 ⁵ / ₁₆ "x23 ⁵ / ₁₆ " 8 mm MATT RT R10 B |  30x60 cm 11 ¹³ / ₁₆ "x23 ⁵ / ₁₆ " 8 mm MATT RT R10 B |  7,2x60 cm 2 ⁷ / ₁₆ "x23 ⁵ / ₁₆ " Battiscopa - Bullnose Plinthe - Sockel Плинтус MATT |
|--------|---------------------------------------------------------------------------------------------------------------------------------------------------------------------------------------------------------|--------------------------------------------------------------------------------------------------------------------------------------------------------------------------------------------------------|---------------------------------------------------------------------------------------------------------------------------------------------------------------------------------------------------------|-------------------------------------------------------------------------------------------------------------------------------------------------------------------------------------------------------------------------------------------------|
| White | ● | ● | ● | ● |
| Taupe | ● | ● | ● | ● |
| Sand | ● | ● | ● | ● |
| Greige | ● | ● | ● | ● |

| IMBALLI - PACKAGING - CONDITIONNEMENT - VERPACKUNGS-EINHEITEN - УПАКОВКА | | | | | | | |
|--------------------------------------------------------------------------|----------------------------------------------------------------------|------------------------------------------|------|--------|---------------------------|-------|----------|
| Formato - Size - Format - Формат | | Scatola - Box - Boîte - Karton - Коробка | | | Pallet - Palette - Палета | | |
| CM | INCHES | PZ | MQ | KG | SC | MQ | KG |
| 60x120 | 23 ⁵ / ₁₆ "x47 ⁷ / ₁₆ " | 2 | 1,44 | ~30,40 | 35 | 50,40 | ~1064,00 |
| 60x60 | 23 ⁵ / ₁₆ "x23 ⁵ / ₁₆ " | 4 | 1,44 | ~24,70 | 30 | 43,20 | ~741,00 |
| 30x60 | 11 ¹³ / ₁₆ "x23 ⁵ / ₁₆ " | 8 | 1,44 | ~24,70 | 40 | 57,60 | ~988,00 |

RT Rettificato, squadrato, monocalibro. - Rectified, squared, one caliber. - Rectifié, mis d'equerre et monocalibre. - Rektifiziert, rechtwinkelig und Ein kaliber. - Ректифицированный, одного калибра.













Si raccomanda l'utilizzo di una fuga di 2/3 mm al fine di semplificare le operazioni di posa e ottimizzare la naturalezza del risultato finale. - We recommend you a 2/3 mm grout joint to simplify the laying and optimize the naturalness of the final result. - Un joint de 2/3 mm est conseillé afin de simplifier les opérations de pose et optimiser l'effet naturel du résultat final. - Es wird empfohlen mit einer Fuge von 2/3 mm zu arbeiten, um am Ende den Verlegvorgang zu vereinfachen und die bestmögliche Natürlichkeit der Arbeit zu erzielen. - Для облегчения операций укладки и повышения натуральности вида конечного результата рекомендуется выполнять шов шириной 2-3 мм.

Al fine di facilitare la manutenzione ordinaria si raccomanda di effettuare un lavaggio acido dopo 48 ore dalla stuccatura con un acido specifico per grès porcellanato. - In order to favour the ordinary maintenance procedures, it is recommended to carry out an acid wash of the surface after 48 hours from grout filling using an acid agent specific for porcelain stoneware tiles. - Afin de faciliter l'entretien ordinaire de votre carrelage, nous vous conseillons de le laver 48 heures après le colmatage des joints, avec un acide spécifique pour grès cérame. - Um die Instandhaltung zu erleichtern, empfiehlt es sich 48 Stunden nach der Stuckatur mit einer sauren Lösung speziell für Feinsteinzeug zu waschen. - Чтобы упростить уход за плиткой, спустя 48 часов после затирки швов рекомендуется выполнить обработку кислотным продуктом, пригодным для керамогранита.

CARATTERISTICHE TECNICHE

TILE PERFORMANCE DATA - NOTES TECHNIQUES - TECHNISCHE AUSKÜNFTE - ТЕХНИЧЕСКАЯ ХАРАКТЕРИСТИКА

Classificazione secondo EN ISO 14411 ISO 13006 annesso G gruppo Bla con Ev ≤0,5% - Classification in accordance with EN ISO 14411 ISO 13006 annex G standards Bla with Ev ≤ 0,5% - Classification selon EN ISO 14411 ISO 13006 annexe G groupe Bla avec Ev ≤0,5% - Klassifizierung gemäß EN ISO 14411 ISO 13006 anlage G Gruppe Bla mit Ev ≤0,5% - Классификация в соответствии с EN ISO 14411 ISO 13006, приложение G, стандарт Bla, где Ev ≤0,5%

| | CARATTERISTICA TECNICA TECHNICAL CHARACTERISTIC CARACTERISTIQUE TECHNIQUE TECHNISCHE DATEN ТЕХНИЧЕСКАЯ ХАРАКТЕРИСТИКА | METODO DI PROVA TESTS METHOD METHODE D'ESSAI TESTMETHODE МЕТОД ИСПЫТАНИЯ | VALORE * MEDIO "CAESAR" AVERAGE * "CAESAR" VALUE * VALEUR * MOYEN "CAESAR" "CAESAR" DURCHSCHNITTSWERT * СРЕДНЕЕ ЗНАЧЕНИЕ "CAESAR" * |
|---------------------------------------------------------------------------------------|------------------------------------------------------------------------------------------------------------------------------------------------------------------------------------------------------------------------------------|--------------------------------------------------------------------------------------|-------------------------------------------------------------------------------------------------------------------------------------------------|
|  | Dimensione - Size Dimension - Abmessungen - Размер | ISO 10545-2 | Conforme - In accordance Conforme - Erfüllt - Соответствует |
|  | Assorbimento d'acqua* - Water absorption* Absorption d'eau* - Wasseraufnahme* - % Поглощения воды* | ISO 10545-3 | ≤ 0,1% |
|  | Resistenza alla flessione* - Bending strength* Résistance à la flexion* - Biegezugfestigkeit* - Упругость* | ISO 10545-4 | Conforme - In accordance Conforme - Erfüllt - Соответствует |
|  | Resistenza all'abrasione profonda* - Deep scratch resistance* Résistance à l'abrasion profonde* - Widerstand gegen Tiefenverschleiß* Устойчивость к глубокому истиранию* | ISO 10545-6 | Conforme - In accordance Conforme - Erfüllt - Соответствует |
|  | Coefficiente di dilatazione termica lineare* - Thermal linear expansion coefficient* Coefficient de dilatation thermique linéaire - Koeffizient der linearen thermischen Dehnung* - Коэффициент линейного теплового расширения* | ISO 10545-8 | = 7 (10 ⁻⁶ °C ⁻¹) |
|  | Resistenza agli sbalzi termici* - Thermal shock resistance* Résistance aux écarts de température* - Temperaturwechsel Beständigkeit* Устойчивость к тепловому перепаду* | ISO 10545-9 | Resistente - Resistant Résistante - Beständig - Стойкий |
|  | Dilatazione all'umidità* - Expansion in humidity* Dilatation à l'humidité* - Feuchtigkeitsausdehnung* Расширение в условиях влажности* | ISO 10545-10 | ≤ 0,1 (mm/m) |
|  | Resistenza al gelo* - Frost resistance* Résistance au gel* - Frostbeständigkeit* - Морозоустойчивость* | ISO 10545-12 | Resistente - Resistant Résistante - Beständig - Стойкий |
|  | Resistenza all'attacco chimico* - Resistance to chemical attack* Résistance à l'attaque chimique* - Beständigkeit gegen Chemikalien* Устойчивость к химическому воздействию* | ISO 10545-13 | Resistente - Resistant Résistante - Beständig - Стойкий |
|  | Resistenza alle macchie* - Resistance to stains* Résistance aux taches* - Fleckenbeständigkeit* Устойчивость к образованию пятен* | ISO 10545-14 | Pulibile - Cleanable Nettoyable - Leicht zu reinigen Чистящийся |
|  | Resistenza allo scivolamento** - Slip resistance** Résistance au glissement** - Rutschhemmende Eigenschaft** Сопротивление скольжению** | DIN 51130 - DIN 51097 ▲ ANSI A326.3 | R10 B Matt Wet DCOF ≥ 0,42 |
|  | Spessore nominale - Nominal Thickness Épaisseur nominale - Nominalstärke Номинальная толщина | | 9 mm 60x120 8 mm 60x60 - 30x60 |

* Valori medi riferiti agli ultimi due anni di produzione e relativi alla finitura naturale del prodotto - Average values referred to the last two years of production and related to the matt finish of the product - Valeurs moyennes des deux dernières années de production et relatifs à la finition naturelle du produit - Durchschnittswerte, die sich auf die letzten zwei Produktionsjahre beziehen und auf die matte Oberfläche - Средние значения относятся к последним двум годам производства и натуральной отделке поверхности

** Valori relativi alla finitura naturale del prodotto ed a test effettuati da laboratori esterni accreditati, disponibili in azienda; ci rendiamo disponibili alla verifica dell'eventuale lotto interessato all'acquisto. - As far as values relating to the matt finish of the product and to tests carried out by certified external laboratories whose results are available upon request at Headoffice, we are willing to check the lot you are interested in purchasing. - Valeurs se référant à la finition naturelle du produit selon des tests effectués par des laboratoires extérieurs accrédités et à la disposition de toute personne intéressée auprès de nos bureaux; nous sommes disponibles pour le contrôle de l'éventuel lot concerné par l'achat. - Werte bezogen auf das natürliche Produktfinish und in anerkannten externen Labors geprüft, im Unternehmen erhältlich; für eventuelle Prüfungen der zu erwerbenden Warenposten stehen wir gern zur Verfügung. - Значения, касающиеся натуральных характеристик изделий и тестов, выполненных внешними авторизованными лабораториями, имеются в компании. Мы готовы выполнить проверку партии товара, которую намереваетесь приобрести.

• Per prodotti chimici di uso domestico e additivi per piscina. - For domestic chemicals and swimming pool additives. - Pour produits chimiques à usage domestique et additifs pour piscines. - Für chemische Produkte für den Hausgebrauch und Schwimmbadzusätze. - Для бытовых химикатов и добавок для бассейнов.

▲ Valori wet DCOF specifici disponibili in azienda - Wet DCOF specific values available at the company - Valeurs wet DCOF spécifiques disponibles à l'usine - Prüfwerte Wet DCOF stehen im Werk zur Verfügung - Показатели wet DCOF доступны при запросе

Le tonalità dei campioni sono da considerarsi puramente indicative. - Tones of samples are indicative. - Les tonalités des échantillons sont purement indicatives. Die farbtöne der Muster sind als rein indicativ zu betrachten. - Тона образцов ориентировочные.

Slab

CCS



Interpretazione ceramica dell'ardesia, Slab si caratterizza per la superficie leggermente strutturata ma dalla mano morbida, con colori che variano dalle classiche tinte scure, cui si contrappongono tonalità chiare, interpretando un grande classico dell'architettura con perfetto equilibrio tra naturalezza e modernità.

The ceramic reinterpretation of natural slate, Slab is characterised by a slightly textured surface with a soft touch, in colours that range from the traditional dark shades to bright hues, the expression of classic architecture in a perfect balance of naturalness and contemporary appeal.

Interprétation céramique de l'ardoise, Slab se caractérise par sa surface légèrement structurée mais douce au toucher; une gamme des couleurs qui comprend des teintes foncées et des teintes claires afin de reproduire fidèlement l'équilibre architectural de naturalité et modernité.

Die keramische Interpretation des Schiefers Slab ist durch eine leicht strukturierte und zugleich weiche Oberfläche geprägt. In Farben, die von klassischen dunklen Nuancen bis zu kontrastierenden, helleren Farbtönen variieren. Die Interpretation eines großen Klassikers der Architektur, in perfektem Gleichgewicht zwischen Natürlichkeit und Modernität.

Керамическая интерпретация сланца, серия Slab характеризуется слегка текстурированной, но мягкой на ощупь поверхностью, цвета варьируются от классических темных оттенков до контрастных светлых, интерпретируя великую классику архитектуры в идеальном балансе между естественностью и современностью.



Info
Resources
Tools

Slab



Colori - Formati

Colors - Sizes

60x60 8 mm MATT RT R10 B

30x60 8 mm MATT NR R10 B

45x90 . 60x60 20 mm AEXTRA20 RT R11 C

KHAKI



COKE



BLACK

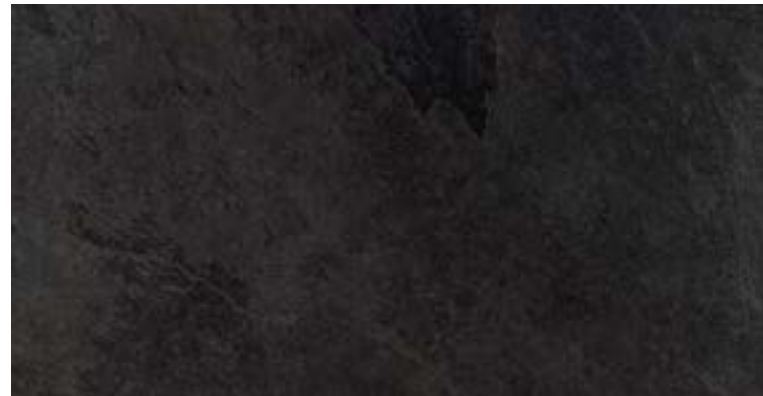

SILVER



SNOW



8 mm



60x60
23⁵/₈"x23⁵/₈"

MATT RT R10 B

8 mm



30x60
11⁵/₈"x23⁵/₈"

MATT NR R10 B

20 mm



45x90
17¹/₈"x35⁷/₈"



60x60
23⁵/₈"x23⁵/₈"

AEXTRA20 RT R11 C

*La liste à jour des produits et formats des séries certifiées QB-UPEC est disponible en usine.

Slab

La gamma

The range

KHAKI

COKE



BLACK



SILVER



SNOW

MATT RT R10 B

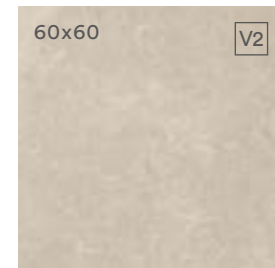
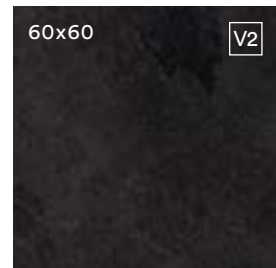
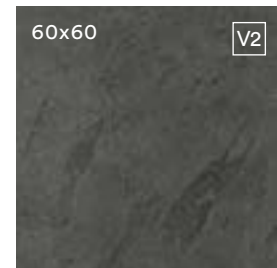

MATT NR R10 B

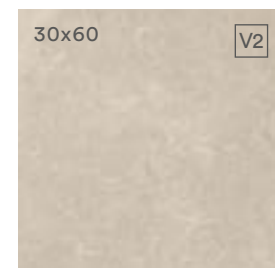
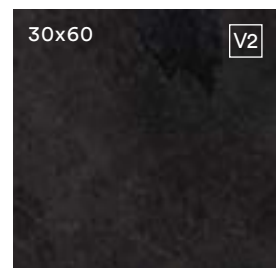
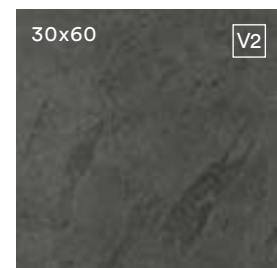

AEXTRA20 RT R11 C

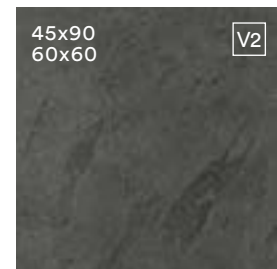

RT Rettificato, squadrato, monocalibro. - Rectified, squared, one caliber. - Rectifié, mis d'équerre et monocalibre. - Rektifiziert, rechtwinkelig und Ein kaliber. - Ректифицированный, одного калибра.
NR Non rettificato. - Not rectified. - Non rectifié. - Nicht rektifiziert. - Не ретицированный.





| | 60x60 cm 23 ⁵ / ₈ "x23 ⁵ / ₈ " 8 mm MATT RT R10 B | 30x60 cm 11 ⁵ / ₈ "x23 ⁵ / ₈ " 8 mm MATT NR R10 B | 45x90 cm 17 ¹ / ₈ "x35 ⁷ / ₈ " 20 mm RT R11 C | 60x60 cm 23 ⁵ / ₈ "x23 ⁵ / ₈ " 20 mm RT R11 C | 7,2x60 cm 2 ⁷ / ₈ "x23 ⁵ / ₈ " MATT |
|--------|--------------------------------------------------------------------------------------------------------|--------------------------------------------------------------------------------------------------------|----------------------------------------------------------------------------------------------------|----------------------------------------------------------------------------------------------------|---------------------------------------------------------------------------------------|
| Khaki | ● | ● | ● | ● | ● |
| Coke | ● | ● | ● | ● | ● |
| Black | ● | ● | ● | ● | ● |
| Silver | ● | ● | ● | ● | ● |
| Snow | ● | ● | ● | ● | ● |

IMBALLI - PACKAGING - CONDITIONNEMENT - VERPACKUNGS-EINHEITEN - УПАКОВКА

| Formato - Size - Format - Формат | | Scatola - Box - Boîte - Karton - Коробка | | | Pallet - Palette - Палета | | |
|----------------------------------|-------------------------------------------------------------------|------------------------------------------|------|--------|---------------------------|-------|----------|
| CM | INCHES | PZ | MQ | KG | SC | MQ | KG |
| 60x60 | 23 ⁵ / ₈ "x23 ⁵ / ₈ " | 4 | 1,44 | ~24,70 | 30 | 43,20 | ~741,00 |
| 30x60 NR | 11 ⁵ / ₈ "x23 ⁵ / ₈ " | 8 | 1,44 | ~25,60 | 40 | 57,60 | ~1024,00 |
| 45x90 A EXTRA 20 | 17 ¹ / ₈ "x35 ⁷ / ₈ " | 2 | 0,81 | ~36,00 | 27 | 21,87 | ~972,00 |
| 60x60 A EXTRA 20 | 23 ⁵ / ₈ "x23 ⁵ / ₈ " | 2 | 0,72 | ~31,66 | 30 | 21,60 | ~949,80 |

RT Rettificato, squadrate, monocolori. - Rectified, squared, one caliber. - Rectifié, mis de querrre et monocalibre. - Rektifiziert, rechteckig und Ein kaliber. - Ректифицированный, одного калибра.
NR Non rettificato. - Not rectified. - Non rectifié. - Nicht rektifiziert. - Не ретицированный.

Si raccomanda l'utilizzo di una fuga di 2/3 mm al fine di semplificare le operazioni di posa e ottimizzare la naturalezza del risultato finale. - We recommend you a 2/3 mm grout joint to simplify the laying and optimize the naturalness of the final result. - Un joint de 2/3 mm est conseillé afin de simplifier les opérations de pose et optimiser l'effet naturel du résultat final. - Es wird empfohlen mit einer Fuge von 2/3 mm zu arbeiten, um am Ende den Verlegvorgang zu vereinfachen und die bestmögliche Natürlichkeit der Arbeit zu erzielen. - Для облегчения операций укладки и повышения натуральности вида конечного результата рекомендуется выполнять шов шириной 2-3 мм.

Al fine di facilitare la manutenzione ordinaria si raccomanda di effettuare un lavaggio acido dopo 48 ore dalla stuccatura con un acido specifico per grès porcellanato. - In order to favour the ordinary maintenance procedures, it is recommended to carry out an acid wash of the surface after 48 hours from grout filling using an acid agent specific for porcelain stoneware tiles. - Afin de faciliter l'entretien ordinaire de votre carrelage, nous vous conseillons de le laver 48 heures après le colmatage des joints, avec un acide spécifique pour grès cérame. - Um die Instandhaltung zu erleichtern, empfiehlt es sich 48 Stunden nach der Stuckatur mit einer sauren Lösung speziell für Feinsteinzeug zu waschen. - Чтобы упростить уход за плиткой, спустя 48 часов после затирки швов рекомендуется выполнить обработку кислотным продуктом, пригодным для керамогранита.

CARATTERISTICHE TECNICHE

TILE PERFORMANCE DATA - NOTES TECHNIQUES - TECHNISCHE AUSKÜNFTE - ТЕХНИЧЕСКАЯ ХАРАКТЕРИСТИКА

Classificazione secondo EN ISO 14411 ISO 13006 annesso G gruppo Bla con Ev ≤0,5% - Classification in accordance with EN ISO 14411 ISO 13006 annex G standards Bla with Ev ≤ 0,5% - Classification selon EN ISO 14411 ISO 13006 annexe G groupe Bla avec Ev ≤0,5% - Klassifizierung gemäß EN ISO 14411 ISO 13006 anlage G Gruppe Bla mit Ev ≤0,5% - Классификация в соответствии с EN ISO 14411 ISO 13006, приложение G, стандарт Bla, где Ev ≤0,5%

| | CARATTERISTICA TECNICA TECHNICAL CHARACTERISTIC CARACTERISTIQUE TECHNIQUE TECHNISCHE DATEN ТЕХНИЧЕСКАЯ ХАРАКТЕРИСТИКА | METODO DI PROVA TESTS METHOD METHODE D'ESSAI TESTMETHODE МЕТОД ИСПЫТАНИЯ | VALORE * MEDIO "CAESAR" AVERAGE "CAESAR" VALUE * VALEUR * MOYEN "CAESAR" "CAESAR" DURCHSCHNITTSWERT * СРЕДНЕЕ ЗНАЧЕНИЕ "CAESAR" * | VALORE * MEDIO "CAESAR" AVERAGE "CAESAR" VALUE A E X T R A 2 0 OPEN YOUR STYLE |
|--|-------------------------------------------------------------------------------------------------------------------------------------------------------------------------------------------------------------------------------------------|--------------------------------------------------------------------------------------|-----------------------------------------------------------------------------------------------------------------------------------------------|--------------------------------------------------------------------------------------------------------------------------------------------------------------------------------------------------------------------------------------------------------------------------|
| | Dimensione - Size Dimension - Abmessungen - Размер | ISO 10545-2 | Conforme - In accordance Conforme - Erfüllt - Соответствует | Conforme - In accordance Conforme - Erfüllt - Соответствует |
| | Assorbimento d'acqua* - Water absorption* Absorption d'eau* - Wasseraufnahme* - % Поглощения воды* | ISO 10545-3 | ≤ 0,1% | ≤ 0,1% |
| | Resistenza alla flessione* - Bending strength* Résistance à la flexion* - Biegezugfestigkeit* - Упругость* | ISO 10545-4 | Conforme - In accordance Conforme - Erfüllt - Соответствует | Non applicabile a piastrelle con una forza di rottura ≥ 3000 N Not applicable to tiles with a breaking strength ≥ 3000 N Nicht pas applicable aux carreaux avec une charge de rupture ≥ 3000 N Не применяется при плитках с прочностью на азрыв ≥ 3000 N |
| | Resistenza all'abrasione profonda* - Deep scratch resistance* Résistance à l'abrasion profonde* - Widerstand gegen Tiefenverschleiß* Устойчивость к глубокому истиранию* | ISO 10545-6 | Conforme - In accordance Conforme - Erfüllt - Соответствует | Conforme - In accordance Conforme - Erfüllt - Соответствует |
| | Coefficiente di dilatazione termica lineare* - Thermal linear expansion coefficient* Coefficient de dilatation thermique linéaire - Koeffizient der linearen thermischen Dehnung* - Коэффициент линейного теплового расширения* | ISO 10545-8 | = 7 (10 ⁻⁶ °C ⁻¹) | = 7 (10 ⁻⁶ °C ⁻¹) |
| | Resistenza agli sbalzi termici* - Termal shock resistance* Résistance aux écarts de température* - Temperaturwechsel Beständigkeit* Устойчивость к тепловому перепаду* | ISO 10545-9 | Resistente - Resistant Résistante - Beständig - Стойкий | Resistente - Resistant Résistante - Beständig - Стойкий |
| | Dilatazione all'umidità* - Expansion in humidity* Dilatation à l'umidité* - Feuchtigkeitsausdehnung* Расширение в условиях влажности* | ISO 10545-10 | ≤ 0,1 (mm/m) | ≤ 0,1 (mm/m) |
| | Resistenza al gelo* - Frost resistance* Résistance au gel* - Frostbeständigkeit* - Морозостойчивость* | ISO 10545-12 | Resistente - Resistant Résistante - Beständig - Стойкий | Resistente - Resistant Résistante - Beständig - Стойкий |
| | Resistenza all'attacco chimico* - Resistance to chemical attack* Résistance à l'attaque chimique* - Beständigkeit gegen Chemikalien* Устойчивость к химическому воздействию* | ISO 10545-13 | Resistente - Resistant Résistante - Beständig - Стойкий | Resistente - Resistant Résistante - Beständig - Стойкий |
| | Carico statico - Static load Charge statique - Statische Last Статическая нагрузка | EN 12825 | - | 60x60 45x90 KN>7,0 KN>5,0 |
| | Classe di carico di rottura*** - Breaking load class*** Classe de charge de rupture*** - Bruchlastklasse*** Класс стойкости к разрушающей нагрузке*** | EN 1339 | - | Centro - Centre - Au centre - Mitte - По центру Centro lato - Side centre - Au centre latéralement Mitte Seite - По центру грани KN>5,0 KN>4,0 |
| | Resistenza alle macchie* - Resistance to stains* Résistance aux taches* - Fleckenbeständigkeit * Устойчивость к образованию пятен* | ISO 10545-14 | Pulibile - Cleanable Nettoyable - Leicht zu reinigen Чистящийся | Diagonale - Diagonal - En diagonale Diagonal - По диагонали KN>8,0 KN>7,0 |
| | Resistenza allo scivolamento** - Slip resistance** Résistance au glissement** - Rutschhemmende Eigenschaft** Сопротивление скольжению** | DIN 51130 DIN 51097 ▲ ANSI A326.3 | R10 B Matt Wet DCOF ≥ 0,42 | U11 T11 Pulibile - Cleanable Nettoyable - Leicht zu reinigen Чистящийся R11 C Wet DCOF ≥ 0,55 |
| | Spessore nominale - Nominal Thickness Épaisseur nominal - Nominalstärke Номинальная толщина | | 8 mm 60x60 - 30x60 NR | 20 mm |

* Valori medi riferiti agli ultimi due anni di produzione e relativi alla finitura naturale del prodotto - Average values referred to the last two years of production and related to the matt finish of the product - Valeurs moyennes des deux dernières années de production et relatifs à la finition naturelle du produit - Durchschnittswerte, die sich auf die letzten zwei Produktionsjahre beziehen und auf die matte Oberfläche - Средние значения относятся к последним двум годам производства и натуральной отделке поверхности

** Valori relativi alla finitura naturale del prodotto ed a test effettuati da laboratori esterni accreditati, disponibili in azienda; ci rendiamo disponibili alla verifica dell'eventuale lotto interessato all'acquisto. - As far as values relating to the matt finish of the product and to tests carried out by certified external laboratories whose results are available upon request at Headoffice, we are willing to check the lot you are interested in purchasing. - Valeurs se référant à la finition naturelle du produit selon des tests effectués par des laboratoires extérieurs accrédités et à la disposition de toute personne intéressée auprès de nos bureaux; nous sommes disponibles pour le contrôle de l'éventuel lot concerné par l'achat. - Werte bezogen auf das natürliche Produktfinish und in anerkannten externen Labors geprüft, im Unternehmen erhältlich; für eventuelle Prüfungen der zu erwerbenden Warenposten stehen wir gern zur Verfügung. -значения, касающиеся натуральных характеристик изделий и тестов, выполненных внешними авторизованными лабораториями, имеются компании. Мы готовы выполнить проверку партии товара, которую намереваетесь приобрести.

*** Dato riferito al formato 60x60 cm. - Detail referred to the 60x60 cm size. - Donnée se rapportant au format 60x60 cm. - Auf die Formate 60x60 cm bezogen. - значения, касающиеся натуральных характеристик изделий и тестов.

• Per prodotti chimici di uso domestico e additivi per piscina. - For domestic chemicals and swimming pool additives. - Pour produits chimiques à usage domestique et additifs pour piscines. - Für chemische Produkte für den Hausgebrauch und Schwimmbadzusätze. - Для бытовых химикатов и добавок для бассейнов.

▲ Valori wet DCOF specifici disponibili in azienda - Wet DCOF specific values available at the company - Valeurs wet DCOF spécifiques disponibles à l'usine - Prüfwerte Wet DCOF stehen im Werk zur Verfügung - Показатели wet DCOF доступны при запросе

Le tonalità dei campioni sono da considerarsi puramente indicative. - Tones of samples are indicative. - Les tonalités des échantillons sont purement indicatives. Die Farbtöne der Muster sind als rein indicativ zu betrachten. - Тона образцов ориентировочные.

Step In & Out



Step In & Out è grès porcellanato dove il mondo delle pietre di recupero e quello dei cementi vissuti convergono in un perfetto equilibrio dal sapore contemporaneo. L'incontro fra la matericità della pietra e la natura industrial del cemento emergono sulla superficie sotto forma di ricercati cromatismi, conferendo al prodotto un sapore caldo e moderno.

Step In & Out is porcelain tile in which the world of reclaimed stone and of worn concrete combine in perfect harmony to offer a contemporary flavour. The encounter between the materity of the stone and the industrial nature of concrete is visible on the surface in the form of refined colour schemes, which give the product a warm, modern flavour.

Step In & Out est le grès cérame où le monde des pierres de récupération et celui des ciments vieillissants convergent dans un équilibre parfait au goût contemporain. La rencontre entre la matière de la pierre et la nature industrielle du ciment se dessine sur la surface, sous forme de chromatismes recherchés, en donnant au produit un aspect chaleureux et moderne.

Step In & Out ist ein Feinsteinzeug, in dem sich die Welt des verwerteten Naturstein und jene des gealterten Zements in einem perfekten Gleichgewicht von zeitgenössischem Appeal begegnen. Die Begegnung der Stofflichkeit des Steins und die industrielle Natur des Zements zeigen sich an der Oberfläche in Form ausgesuchter Farbeffekte und verleihen dem Produkt eine warme und moderne Ausstrahlung.

Step In & Out - это керамогранит, в котором в идеальном балансе и с современным вкусом встречаются мир переработанного камня и мир состаренного цемента. Встреча между фактурностью камня и индустриальным характером цемента воплощается на поверхности в виде утонченных сочетаний цветов, придающих продукту теплый и современный вид.



Step In



Step Out



Info
Resources
Tools



Floor: (IN) **STEP IN DUST** 30x60 MATT RT R10 B, (OUT) **STEP OUT GREY** 30x60 MATT NR R11 C
Wall: (IN) **STEP IN DUST** 30x60 MATT RT R10 B, **COMPOSIZIONE M** 30x30 MATT
Furniture by CLOS: **ANIMA FUTURA AMAZING SILVER LUCIDATO**

Step In & Out



Colori - Formati

Colors - Sizes

60x60 . 30x60 8 mm MATT RT R10 B

30x60 8 mm MATT NR R11 C

STEP IN DUST



STEP OUT DUST



STEP IN GREY



STEP OUT GREY



STEP IN TAUPE



STEP OUT TAUPE



STEP IN DARK



STEP OUT DARK



8 mm



60x60
23⁵/₈"x23⁵/₈"



30x60
11⁵/₈"x23⁵/₈"

MATT RT R10 B

8 mm



30x60
11⁵/₈"x23⁵/₈"

MATT NR R11 C

*La liste a jour des produits et formats des series certifiees QB-UPEC est disponible en usine.

Step In & Out

La gamma The range

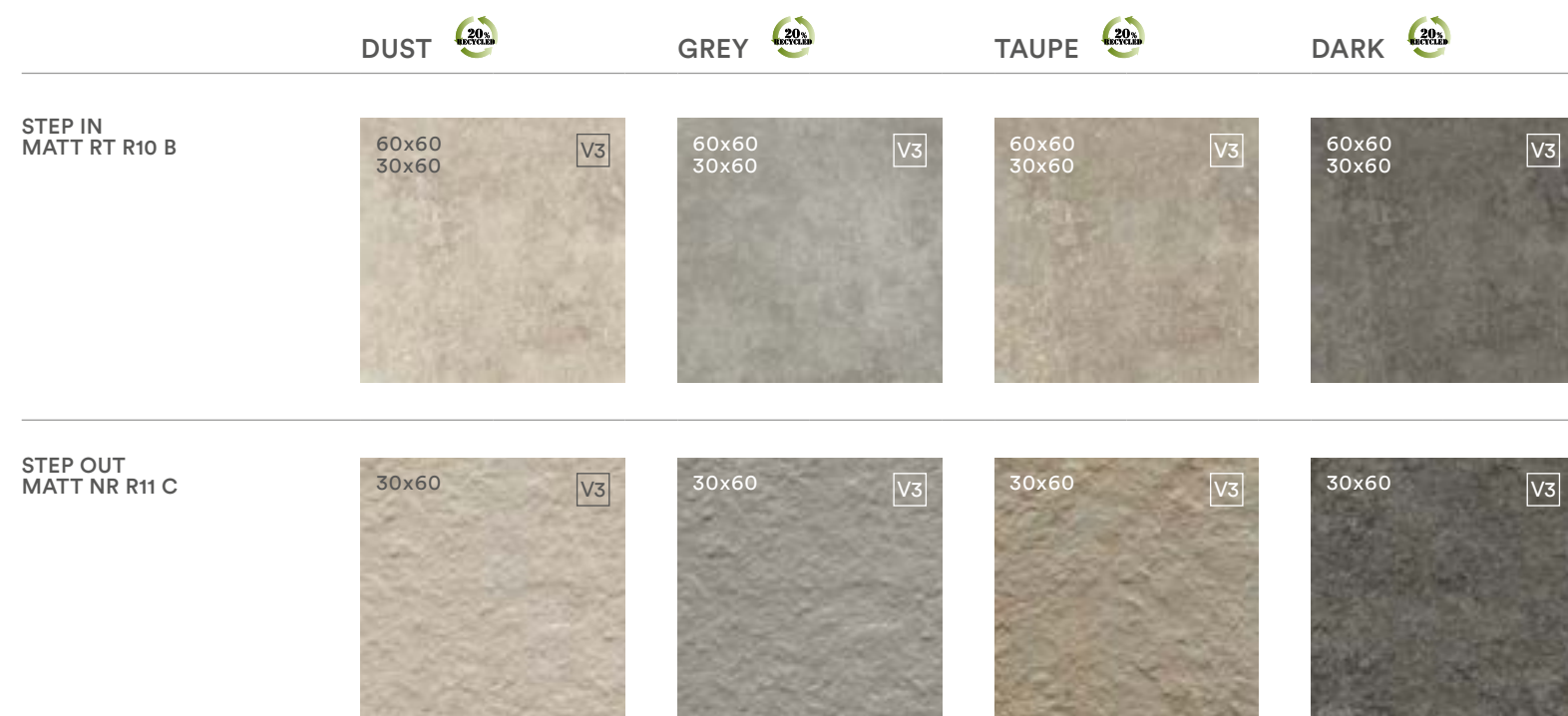

Decori Decors



COMPOSIZIONE M 30x30 cm . 11¹³/₁₆"x11¹³/₁₆" MATT





RT Rettificato, squadrato, monocalibro. - Rectified, squared, one caliber. - Rectifié, mis d'équerre et monocalibre. - Rektifiziert, rechtwinkelig und Ein kaliber. - Ректифицированный, одного калибра.
NR Non rettificato. - Not rectified. - Non rectifié. - Nicht rektifiziert. - Не ретицированный.

Step In & Out



| |  60x60 cm 23 ⁵ / ₁₆ "x23 ⁵ / ₁₆ " 8 mm MATT RT R10 B (STEP IN) |  30x60 cm 11 ¹³ / ₁₆ "x23 ⁵ / ₁₆ " 8 mm MATT RT R10 B (STEP IN) |  30x60 cm 11 ¹³ / ₁₆ "x23 ⁵ / ₁₆ " 8 mm MATT NR R11 C (STEP OUT) |
|-------|----------------------------------------------------------------------------------------------------------------------------------------------------------------------------------------------------------------|-----------------------------------------------------------------------------------------------------------------------------------------------------------------------------------------------------------------|-------------------------------------------------------------------------------------------------------------------------------------------------------------------------------------------------------------------|
| Dust | ● | ● | ● |
| Grey | ● | ● | ● |
| Taupe | ● | ● | ● |
| Dark | ● | ● | ● |

| |  Battiscopa - Bullnose Plinthe - Sockel Плинтус 7,2x60 cm 2 ⁷ / ₁₆ "x23 ⁵ / ₁₆ " MATT (STEP IN) |  Battiscopa - Bullnose Plinthe - Sockel Плинтус 7,2x30 cm 2 ⁷ / ₁₆ "x11 ¹³ / ₁₆ " MATT (STEP OUT) |  Elemento L - Rounded covensing Nez de marche - "L" Schenkel Элемент L 15x30 cm 5 ⁷ / ₁₆ "x11 ¹³ / ₁₆ " MATT (STEP OUT) |
|-------|---------------------------------------------------------------------------------------------------------------------------------------------------------------------------------------------------------------------------------------------------------|-----------------------------------------------------------------------------------------------------------------------------------------------------------------------------------------------------------------------------------------------------------|---------------------------------------------------------------------------------------------------------------------------------------------------------------------------------------------------------------------------------------------------------------------------------|
| Dust | ● | ● | ● |
| Grey | ● | ● | ● |
| Taupe | ● | ● | ● |
| Dark | ● | ● | ● |

| IMBALLI - PACKAGING - CONDITIONNEMENT - VERPACKUNGS-EINHEITEN - УПАКОВКА | | | | | | | |
|--------------------------------------------------------------------------|----------------------------------------------------------------------|------------------------------------------|------|--------|---------------------------|-------|----------|
| Formato - Size - Format - Формат | | Scatola - Box - Boîte - Karton - Коробка | | | Pallet - Palette - Палета | | |
| CM | INCHES | PZ | MQ | KG | SC | MQ | KG |
| 60x60 STEP in | 23 ⁵ / ₁₆ "x23 ⁵ / ₁₆ " | 4 | 1,44 | ~24,70 | 30 | 43,20 | ~741,00 |
| 30x60 STEP in | 11 ¹³ / ₁₆ "x23 ⁵ / ₁₆ " | 8 | 1,44 | ~24,70 | 40 | 57,60 | ~988,00 |
| 30x60 STEP out | 11 ¹³ / ₁₆ "x23 ⁵ / ₁₆ " | 8 | 1,44 | ~25,60 | 40 | 57,60 | ~1024,00 |

RT Rettificato, squadrato, monocalibro. - Rectified, squared, one caliber. - Rectifié, mis d'équerre et monocalibre. - Rektifiziert, rechtwinkelig und Ein kaliber. - Ректифицированный, одного калибра.
NR Non rettificato. - Not rectified. - Non rectifié. - Nicht rektifiziert. - Не ретифицированный.
 ** Disponibile solo su richiesta. - Manufactured only upon special request. - Seulement sur demande. - Nur auf Anfrage. - Производится только по заказу.













Si raccomanda l'utilizzo di una fuga di 2/3 mm al fine di semplificare le operazioni di posa e ottimizzare la naturalezza del risultato finale. - We recommend you a 2/3 mm grout joint to simplify the laying and optimize the naturalness of the final result. - Un joint de 2/3 mm est conseillé afin de simplifier les opérations de pose et optimiser l'effet naturel du résultat final. - Es wird empfohlen mit einer Fuge von 2/3 mm zu arbeiten, um am Ende den Verlegvorgang zu vereinfachen und die bestmögliche Natürlichkeit der Arbeit zu erzielen. - Для облегчения операций укладки и повышения натуральности вида конечного результата рекомендуется выполнять шов шириной 2-3 мм.

Al fine di facilitare la manutenzione ordinaria si raccomanda di effettuare un lavaggio acido dopo 48 ore dalla stuccatura con un acido specifico per grès porcellanato. - In order to favour the ordinary maintenance procedures, it is recommended to carry out an acid wash of the surface after 48 hours from grout filling using an acid agent specific for porcelain stoneware tiles. - Afin de faciliter l'entretien ordinaire de votre carrelage, nous vous conseillons de le laver 48 heures après le colmatage des joints, avec un acide spécifique pour grès cérame. - Um die Instandhaltung zu erleichtern, empfiehlt es sich 48 Stunden nach der Stuckatur mit einer sauren Lösung speziell für Feinsteinzeug zu waschen. - Чтобы упростить уход за плиткой, спустя 48 часов после затирки швов рекомендуется выполнить обработку кислотным продуктом, пригодным для керамогранита.

CARATTERISTICHE TECNICHE

TILE PERFORMANCE DATA - NOTES TECHNIQUES - TECHNISCHE AUSKÜNFTE - ТЕХНИЧЕСКАЯ ХАРАКТЕРИСТИКА

Classificazione secondo EN ISO 14411 ISO 13006 annesso G gruppo Bla con Ev ≤0,5% - Classification in accordance with EN ISO 14411 ISO 13006 annex G standards Bla with Ev ≤ 0,5% - Classification selon EN ISO 14411 ISO 13006 annexe G groupe Bla avec Ev ≤0,5% - Klassifizierung gemäß EN ISO 14411 ISO 13006 anlage G Gruppe Bla mit Ev ≤0,5% - Классификация в соответствии с EN ISO 14411 ISO 13006, приложение G, стандарт Bla, где Ev ≤0,5%

| | CARATTERISTICA TECNICA TECHNICAL CHARACTERISTIC CARACTERISTIQUE TECHNIQUE TECHNISCHE DATEN ТЕХНИЧЕСКАЯ ХАРАКТЕРИСТИКА | METODO DI PROVA TESTS METHOD METHODE D'ESSAI TESTMETHODE МЕТОД ИСПЫТАНИЯ | VALORE * MEDIO "CAESAR" AVERAGE "CAESAR" VALUE * VALEUR * MOYEN "CAESAR" "CAESAR" DURCHSCHNITTSWERT * СРЕДНЕЕ ЗНАЧЕНИЕ "CAESAR" * |
|---------------------------------------------------------------------------------------|------------------------------------------------------------------------------------------------------------------------------------------------------------------------------------------------------------------------------------|--------------------------------------------------------------------------------------|-----------------------------------------------------------------------------------------------------------------------------------------------|
|  | Dimensione - Size Dimension - Abmessungen - Размер | ISO 10545-2 | Conforme - In accordance Conforme - Erfüllt - Соответствует |
|  | Assorbimento d'acqua* - Water absorption* Absorption d'eau* - Wasseraufnahme* - % Поглощения воды* | ISO 10545-3 | ≤ 0,1% |
|  | Resistenza alla flessione* - Bending strength* Résistance à la flexion* - Biegezugfestigkeit* - Упругость* | ISO 10545-4 | Conforme - In accordance Conforme - Erfüllt - Соответствует |
|  | Resistenza all'abrasione profonda* - Deep scratch resistance* Résistance à l'abrasion profonde* - Widerstand gegen Tiefenverschleiß* Устойчивость к глубокому истиранию* | ISO 10545-6 | Conforme - In accordance Conforme - Erfüllt - Соответствует |
|  | Coefficiente di dilatazione termica lineare* - Thermal linear expansion coefficient* Coefficient de dilatation thermique linéaire - Koeffizient der linearen thermischen Dehnung* - Коэффициент линейного теплового расширения* | ISO 10545-8 | = 7 (10 ⁻⁶ °C ⁻¹) |
|  | Resistenza agli sbalzi termici* - Thermal shock resistance* Résistance aux écarts de température* - Temperaturwechsel Beständigkeit* Устойчивость к тепловому перепаду* | ISO 10545-9 | Resistente - Resistant Résistante - Beständig - Стойкий |
|  | Dilatazione all'umidità* - Expansion in humidity* Dilatation à l'humidité* - Feuchtigkeitsausdehnung* Расширение в условиях влажности* | ISO 10545-10 | ≤ 0,1 (mm/m) |
|  | Resistenza al gelo* - Frost resistance* Résistance au gel* - Frostbeständigkeit* - Морозостойкость* | ISO 10545-12 | Resistente - Resistant Résistante - Beständig - Стойкий |
|  | Resistenza all'attacco chimico* - Resistance to chemical attack* Résistance à l'attaque chimique* - Beständigkeit gegen Chemikalien* Устойчивость к химическому воздействию* | ISO 10545-13 | Resistente - Resistant Résistante - Beständig - Стойкий |
|  | Resistenza alle macchie* - Resistance to stains* Résistance aux taches* - Fleckenbeständigkeit* Устойчивость к образованию пятен* | ISO 10545-14 | Pulibile - Cleanable Nettoyable - Leicht zu reinigen Чистящийся |
|  | Resistenza allo scivolamento** - Slip resistance** Résistance au glissement** - Rutschhemmende Eigenschaft** Сопротивление скольжению** | DIN 51130 - DIN 51097 ▲ ANSI A32.3 | R10 B Matt Wet DCOF ≥ 0,42 Wet DCOF ≥ 0,55 |
|  | Spessore nominale - Nominal Thickness Épaisseur nominal - Nominalstärke Номинальная толщина | | 8 mm (STEP IN 60x60, 30x60) 8 mm (STEP OUT 30x60) |

* Valori medi riferiti agli ultimi due anni di produzione e relativi alla finitura naturale del prodotto - Average values referred to the last two years of production and related to the matt finish of the product - Valeurs moyennes des deux dernières années de production et relatifs à la finition naturelle du produit - Durchschnittswerte, die sich auf die letzten zwei Produktionsjahre beziehen und auf die matte Oberfläche - Средние значения относятся к последним двум годам производства и натуральной отделке поверхности

** Valori relativi alla finitura naturale del prodotto ed a test effettuati da laboratori esterni accreditati, disponibili in azienda; ci rendiamo disponibili alla verifica dell'eventuale lotto interessato all'acquisto. - As far as values relating to the matt finish of the product and to tests carried out by certified external laboratories whose results are available upon request at Headoffice, we are willing to check the lot you are interested in purchasing. - Valeurs se référant à la finition naturelle du produit selon des tests effectués par des laboratoires extérieurs accrédités et à la disposition de toute personne intéressée après de nos bureaux; nous sommes disponibles pour le contrôle de l'éventuel lot concerné par l'achat. - Werte bezogen auf das natürliche Produktfinish und in anerkannten externen Labors geprüft, im Unternehmen erhältlich; für eventuelle Prüfungen der zu erwerbenden Warenposten stehen wir gern zur Verfügung. - Значения, касающиеся натуральных характеристик изделий и тестов, выполненных внешними авторизованными лабораториями, имеются в компании. Мы готовы выполнить проверку партии товара, которую намереваетесь приобрести.

• Per prodotti chimici di uso domestico e additivi per piscina. - For domestic chemicals and swimming pool additives. - Pour produits chimiques à usage domestique et additifs pour piscines. - Für chemische Produkte für den Hausgebrauch und Schwimmbadzusätze. - Для бытовых химикатов и добавок для бассейнов.

▲ Valori wet DCOF specifici disponibili in azienda - Wet DCOF specific values available at the company - Valeurs wet DCOF spécifiques disponibles à l'usine - Prüfwerte Wet DCOF stehen im Werk zur Verfügung - Показатели wet DCOF доступны при запросе

Le tonalità dei campioni sono da considerarsi puramente indicative. - Tones of samples are indicative. - Les tonalités des échantillons sont purement indicatives. Die farbtöne der Muster sind als rein indicativ zu betrachten. - Тона образцов ориентировочные.

Wide



Con Wide, la moderna materia ceramica rivela il fascino autentico del cemento metropolitano. Leggeri passaggi cromatici in superficie evocano le imperfezioni e i segni lasciati dal tempo, per dare agli spazi un sapore vagamente industriale in piena sintonia con i canoni stilistici contemporanei.

With Wide collection, the modern ceramic material reveals the authentic charm of metropolitan cement style. The chromatic shading on the surface evokes the imperfections and marks of time, to give spaces a slightly industrial look in harmony with cutting-edge style trends.

Avec Wide, la matière céramique moderne révèle le charme authentique du ciment métropolitain. De légères variations chromatiques sur la surface évoquent les imperfections et les signes laissés par le temps, pour donner aux espaces un allure vaguement industrielle en parfaite harmonie avec les tendances stylistiques contemporaines.

Mit Wide zeigt die moderne Keramik die ganze Faszination des großstädtischen Zements. Leichte Farbnuancierungen auf der Oberfläche evozieren das Vergehen und die Zeichen der Zeit. Damit erhält der Raum jenen gewissen industriellen Charme, der die heutigen Stiltrends prägt.

Линейка Wide – это современный керамический материал, обладающий очарованием цемента. Легкие цветовые переходы на поверхности напоминают о несовершенствах и следах, оставленных временем, чтобы придать помещениям легкий индустриальный колорит в полной гармонии с современными стилистическими канонами.



Info
Resources
Tools



Colori - Formati

Colors - Sizes

60x60 9 mm MATT RT R10 A
30x60 8,5 mm MATT NR R10 A
60x60 9 mm GRIP RT R11 B

VAPOUR



FOG



STEEL



STREET



9 mm



60x60
23⁵/₈"x23⁵/₈"

MATT RT R10 A

8,5 mm



30x60
11³/₈"x23⁵/₈"

MATT NR R10 A

9 mm



60x60
23⁵/₈"x23⁵/₈"









GRIP RT R11 B

*La liste a jour des produits et formats des series certifiees QB-UPEC est disponible en usine.

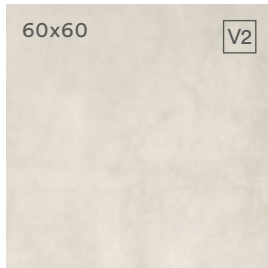
Wide

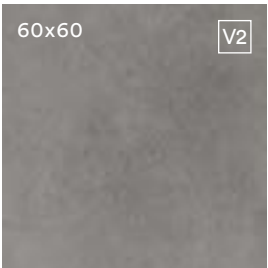
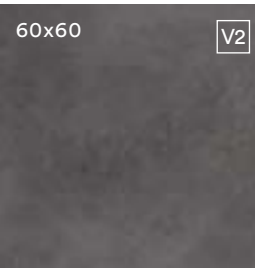
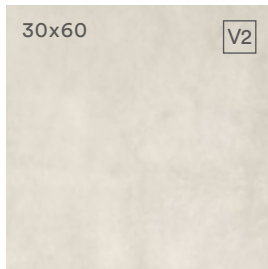
La gamma

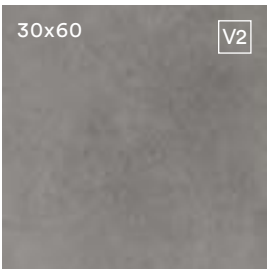
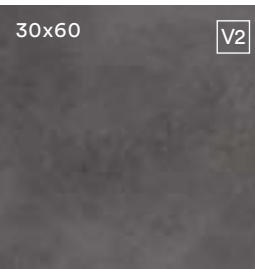
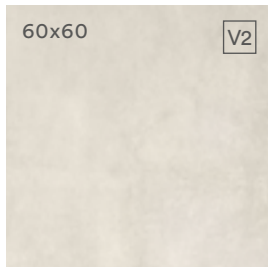
The range

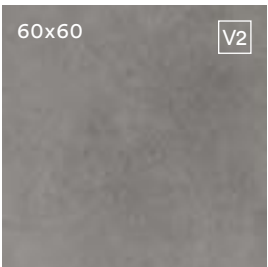
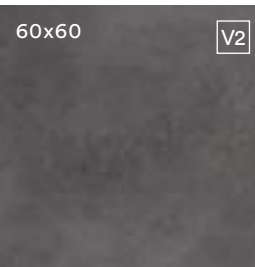
| | VAPOUR | FOG  | STEEL  | STREET  |
|---------------|-------------------------------------------------------------------------------------|---------------------------------------------------------------------------------------|-------------------------------------------------------------------------------------------|--------------------------------------------------------------------------------------------|
| MATT RT R10 A |  |  |  |  |
| MATT NR R10 A |  |  |  |  |
| GRIP RT R11 B |  |  |  |  |

RT Rettificato, quadrato, monocalibro. - Rectified, squared, one caliber. - Rectifié, mis d'équerre et monocalibre. - Rektifiziert, rechtwinkelig und Ein kaliber. - Ректифицированный, одного калибра.
NR Non rettificato. - Not rectified. - Non rectifié. - Nicht rektifiziert. - Не ретифицированный.



Floor: STEEL 60x60 MATT RT R10 A
Wall: STEEL 60x60 MATT RT R10 A



| | | | | | |
|--------|-------------------------------------------------------------------------------------------------------------------|---------------------------------------------------------------------------------------------------------------------|-------------------------------------------------------------------------------------------------------------------|--------------------------------------------------------------------------------------------------|----------------------------------------------------------|
| | 60x60 cm 23 ⁵ / ₈ "x23 ⁵ / ₈ " 9 mm MATT RT R10 A | 30x60 cm 11 ³ / ₈ "x23 ⁵ / ₈ " 8,5 mm MATT NR R10 A | 60x60 cm 23 ⁵ / ₈ "x23 ⁵ / ₈ " 9 mm GRIP RT R11 B | 7,2x60 cm 2 ⁵ / ₈ "x23 ⁵ / ₈ " MATT | Battiscopa - Bullnose Plinthe - Sockel Плинтус |
| Vapour | ● | ● | ● | ● | |
| Fog | ● | ● | ● | ● | |
| Steel | ● | ● | ● | ● | |
| Street | ● | ● | ● | ● | |

IMBALLI - PACKAGING - CONDITIONNEMENT - VERPACKUNGS-EINHEITEN - УПАКОВКА

| Formato - Size - Format - Формат | | Scatola - Box - Boîte - Karton - Коробка | | | Pallet - Palette - Палета | | |
|----------------------------------|-------------------------------------------------------------------|------------------------------------------|------|--------|---------------------------|-------|---------|
| CM | INCHES | PZ | MQ | KG | SC | MQ | KG |
| 60x60 | 23 ⁵ / ₈ "x23 ⁵ / ₈ " | 4 | 1,44 | ~26,79 | 30 | 43,20 | ~803,70 |
| 30x60 | 11 ³ / ₈ "x23 ⁵ / ₈ " | 7 | 1,26 | ~22,75 | 40 | 50,40 | ~910,00 |

RT Rettificato, squadrato, monocalibro. - Rectified, squared, one caliber. - Rectifié, mis d'équerre et monocalibre. - Rektifiziert, rechtwinkelig und Ein kaliber. - Ректифицированный, одного калибра.

NR Non rettificato. - Not rectified. - Non rectifié. - Nicht rektifiziert. - Не ретицированный.

Si raccomanda l'utilizzo di una fuga di 2/3 mm al fine di semplificare le operazioni di posa e ottimizzare la naturalezza del risultato finale. - We recommend you a 2/3 mm grout joint to simplify the laying and optimize the naturalness of the final result. - Un joint de 2/3 mm est conseillé afin de simplifier les opérations de pose et optimiser l'effet naturel du résultat final. - Es wird empfohlen mit einer Fuge von 2/3 mm zu arbeiten, um am Ende den Verlegevorgang zu vereinfachen und die bestmögliche Natürlichkeit der Arbeit zu erzielen. - Для облегчения операций укладки и повышения натуральности вида конечного результата рекомендуется выполнять шов шириной 2-3 мм.

Al fine di facilitare la manutenzione ordinaria si raccomanda di effettuare un lavaggio acido dopo 48 ore dalla stuccatura con un acido specifico per grès porcellanato. - In order to favour the ordinary maintenance procedures, it is recommended to carry out an acid wash of the surface after 48 hours from grout filling using an acid agent specific for porcelain stoneware tiles. - Afin de faciliter l'entretien ordinaire de votre carrelage, nous vous conseillons de le laver 48 heures après le colmatage des joints, avec un acide spécifique pour grès cérame. - Um die Instandhaltung zu erleichtern, empfiehlt es sich 48 Stunden nach der Stuckatur mit einer sauren Lösung speziell für Feinsteinzeug zu waschen. - Чтобы упростить уход за плиткой, спустя 48 часов после затирки швов рекомендуется выполнить обработку кислотным продуктом, пригодным для керамогранита.

CARATTERISTICHE TECNICHE

TILE PERFORMANCE DATA - NOTES TECHNIQUES - TECHNISCHE AUSKÜNFTE - ТЕХНИЧЕСКАЯ ХАРАКТЕРИСТИКА

Classificazione secondo EN ISO 14411 ISO 13006 annesso G gruppo Bla con Ev ≤0,5% - Classification in accordance with EN ISO 14411 ISO 13006 annex G standards Bla with Ev ≤ 0,5% - Classification selon EN ISO 14411 ISO 13006 annexe G groupe Bla avec Ev ≤0,5% - Klassifizierung gemäß EN ISO 14411 ISO 13006 anlage G Gruppe Bla mit Ev ≤0,5% - Классификация в соответствии с EN ISO 14411 ISO 13006, приложение G, стандарт Bla, где Ev ≤0,5%

| | CARATTERISTICA TECNICA TECHNICAL CHARACTERISTIC CARACTERISTIQUE TECHNIQUE TECHNISCHE DATEN ТЕХНИЧЕСКАЯ ХАРАКТЕРИСТИКА | METODO DI PROVA TESTS METHOD METHODE D'ESSAI TESTMETHODE МЕТОД ИСПЫТАНИЯ | VALORE * MEDIO "CAESAR" AVERAGE "CAESAR" VALUE* VALEUR * MOYEN "CAESAR" "CAESAR" DURCHSCHNITTSWERT* СРЕДНЕЕ ЗНАЧЕНИЕ "CAESAR"* | |
|--|------------------------------------------------------------------------------------------------------------------------------------------------------------------------------------------------------------------------------------|--------------------------------------------------------------------------------------|--------------------------------------------------------------------------------------------------------------------------------------------|--------------------------------------|
| | Dimensione - Size Dimension - Abmessungen - Размер | ISO 10545-2 | Conforme - In accordance Conforme - Erfüllt - Соответствует | |
| | Assorbimento d'acqua* - Water absorption* Absorption d'eau* - Wasseraufnahme* - % Поглощения воды* | ISO 10545-3 | ≤ 0,1% | |
| | Resistenza alla flessione* - Bending strength* Résistance à la flexion* - Biegezugfestigkeit* - Упругость* | ISO 10545-4 | Conforme - In accordance Conforme - Erfüllt - Соответствует | |
| | Resistenza all'abrasione profonda* - Deep scratch resistance* Résistance à l'abrasion profonde* - Widerstand gegen Tiefenverschleiß* Устойчивость к глубокому истиранию* | ISO 10545-6 | Conforme - In accordance Conforme - Erfüllt - Соответствует | |
| | Coefficiente di dilatazione termica lineare* - Thermal linear expansion coefficient* Coefficient de dilatation thermique linéaire - Koeffizient der linearen thermischen Dehnung* - Коэффициент линейного теплового расширения* | ISO 10545-8 | = 7 (10 ⁻⁶ °C ⁻¹) | |
| | Resistenza agli sbalzi termici* - Thermal shock resistance* Résistance aux écarts de température* - Temperaturwechsel Beständigkeit* Устойчивость к тепловому перепаду* | ISO 10545-9 | Resistente - Resistant Résistante - Beständig - Стойкий | |
| | Dilatazione all'umidità* - Expansion in humidity* Dilatation à l'humidité* - Feuchtigkeitsausdehnung* Расширение в условиях влажности* | ISO 10545-10 | ≤ 0,1 (mm/m) | |
| | Resistenza al gelo* - Frost resistance* Résistance au gel* - Frostbeständigkeit* - Морозостойчивость* | ISO 10545-12 | Resistente - Resistant Résistante - Beständig - Стойкий | |
| | Resistenza all'attacco chimico* - Resistance to chemical attack* Résistance à l'attaque chimique* - Beständigkeit gegen Chemikalien* Устойчивость к химическому воздействию* | ISO 10545-13 | Resistente - Resistant Résistante - Beständig - Стойкий | |
| | Resistenza alle macchie* - Resistance to stains* Résistance aux taches* - Fleckenbeständigkeit* Устойчивость к образованию пятен* | ISO 10545-14 | Pulibile - Cleanable Nettoyable - Leicht zu reinigen Чистящийся | |
| | Resistenza allo scivolamento** - Slip resistance** Résistance au glissement** - Rutschhemmende Eigenschaft** Сопротивление скольжению** | DIN 51130 - DIN 51097 ▲ ANSI A326.3 | R10 A Matt Wet DCOF ≥ 0,42 | R11 B Grip Wet DCOF ≥ 0,55 |
| | Spessore nominale - Nominal Thickness Épaisseur nominal - Nominalstärke Номинальная толщина | | 9 mm 60x60 8,5 mm 30x60 | 9 mm |

* Valori medi riferiti agli ultimi due anni di produzione e relativi alla finitura naturale del prodotto - Average values referred to the last two years of production and related to the matt finish of the product - Valeurs moyennes des deux dernières années de production et relatifs à la finition naturelle du produit - Durchschnittswerte, die sich auf die letzten zwei Produktionsjahre beziehen und auf die matte Oberfläche - Средние значения относятся к последним двум годам производства и натуральной отделке поверхности

** Valori relativi alla finitura naturale del prodotto ed a test effettuati da laboratori esterni accreditati, disponibili in azienda; ci rendiamo disponibili alla verifica dell'eventuale lotto interessato all'acquisto. - As far as values relating to the matt finish of the product and to tests carried out by certified external laboratories whose results are available upon request at Headoffice, we are willing to check the lot you are interested in purchasing. - Valeurs se référant à la finition naturelle du produit selon des tests effectués par des laboratoires extérieurs accrédités et à la disposition de toute personne intéressée auprès de nos bureaux; nous sommes disponibles pour le contrôle de l'éventuel lot concerné par l'achat. - Werte bezogen auf das natürliche Produktfinish und in anerkannten externen Labors geprüft, im Unternehmen erhältlich; für eventuelle Prüfungen der zu erwerbenden Warenposten stehen wir gern zur Verfügung. - Значения, касающиеся натуральных характеристик изделий и тестов, выполненных внешними авторизованными лабораториями, имеются в компании. Мы готовы выполнить проверку партии товара, которую намереваетесь приобрести.

• Per prodotti chimici di uso domestico e additivi per piscina. - For domestic chemicals and swimming pool additives. - Pour produits chimiques à usage domestique et additifs pour piscines. - Für chemische Produkte für den Hausgebrauch und Schwimmbadzusätze. - Для бытовых химикатов и добавок для бассейнов.

▲ Valori wet DCOF specifici disponibili in azienda - Wet DCOF specific values available at the company - Valeurs wet DCOF spécifiques disponibles à l'usine - Prüfwerte Wet DCOF stehen im Werk zur Verfügung - Показатели wet DCOF доступны при запросе

Le tonalità dei campioni sono da considerarsi puramente indicative. - Tones of samples are indicative. - Les tonalités des échantillons sont purement indicatives. Die farbtöne der Muster sind als rein indicativ zu betrachten. - Тона образцов ориентировочные.

Deco Solutions

New decorations for unique projects



Un'ampia offerta di decori in formato 60x120 e 120x278, abbinabili con tutte le collezioni Caesar. Trame, colori e disegni componibili permettono di caratterizzare con stile i tuoi progetti di architettura e di interior design.

A wide offer of decorations in size 60x120 and 120x278, that can be combined with all Caesar collections. Textures, colours and modular designs are available to characterise your architectural and interior design projects with style.

Une large offre de décorations en format 60x120 et 120x278, qui peuvent être combinées avec toutes les collections Caesar. Les textures, les couleurs et les motifs modulaires permettent de caractériser avec style vos projets d'architecture et de décoration d'intérieur.

Ein breites Angebot an Dekoren in den Formaten 60x120 und 120x278, die mit allen Kollektionen von Caesar kombiniert werden können. Diese Texturen, Farben und modulare Designs ermöglichen es, architektonische und innenarchitektonische Projekte mit Stil zu gestalten.

Широкий выбор декоров форматом 60x120 и 120x278, которые сочетаются со всеми коллекциями Caesar. Текстуры, цвета и компоуемые узоры позволяют стильно оформить ваши архитектурные и интерьерные проекты.



Info
Resources
Tools



Floor: COCOON EASE CHEVRON ARCH 20x120 MATT
Wall: PAMPA 120x278 MATT RT

Formati

Sizes

- 120x278 6 mm MATT RT
- 120x278 6 mm LUCIDATO RT
- 60x120 9 mm MATT RT



6 mm



120x278
47²/₈"x109⁷/₁₆"

MATT RT
LUCIDATO RT

9 mm



60x120
23⁵/₈"x47²/₈"

MATT RT

Deco Solutions

La gamma DECO_ 60x120

The DECO_ 60x120 range

60x120 cm . 23⁵/₈"x47²/₈" MATT RT



FLOWER

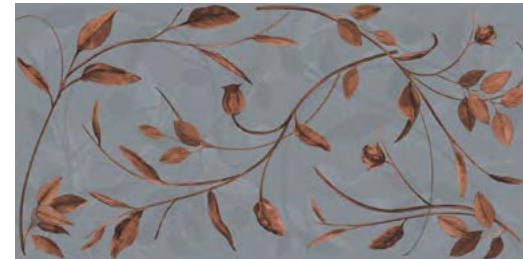

LEAF



PEONIA



ROSE

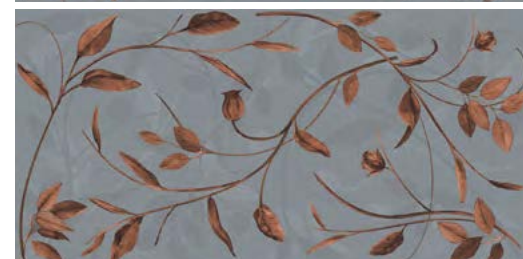
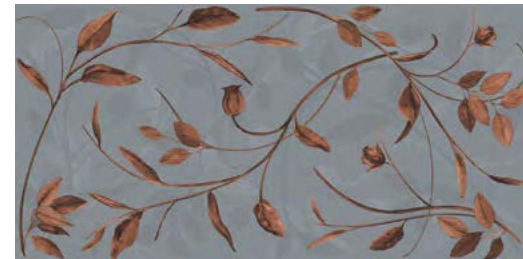

I decori 60x120 si sviluppano a grafica unica in continuità, raccordandosi su ogni lato. Possono essere posati con orientamento sia verticale che orizzontale.

The 60x120 decorations are developed in a single, continuous graphic pattern, connecting on each side. They can be installed in either vertical or horizontal direction.

Les décors 60x120 se développent sous forme de graphiques uniques en continuité, en se raccordant de chaque côté. Ils peuvent être posés à la fois verticalement et horizontalement.

Die Dekore im Format 60x120 werden in einer Grafik in Kontinuität entwickelt, die auf jeder Seite weitergeführt wird. Sie können sowohl in vertikaler als auch in horizontaler Ausrichtung verlegt werden.

Декоры 60x120 разработаны как единое графическое целое с непрерывными переходами узора в любую сторону. Их можно укладывать как по вертикали, так и по горизонтали.

RT Rettificato, squadrato, monocalibro. - Rectified, squared, one caliber. - Rectifié, mis d'équerre et monocalibre. - Rektifiziert, rechtwinkelig und Ein kaliber. - Ректифицированный, одного калибра.

La gamma DECO_ 120x278

The DECO_ 120x278 range

IMPRESSION 120x278 cm . 47²/₈"x109⁷/₁₆" MATT RT

Range faces



Realizzato su **Prima** - Ecrú.
Made on **Prima** - Ecrú.
Fabriqué sur **Prima** - Ecrú.
Realisiert bei **Prima** - Ecrú.
Реализовано на основе **Prima** - Ecrú.

RAMMED 120x278 cm . 47²/₈"x109⁷/₁₆" MATT RT

Range faces



RT Rettificato, quadrato, monocalibro. - Rectified, squared, one caliber. - Rectifié, mis d'équerre et monocalibre. - Rektifiziert, rechtwinkelig und Ein kaliber. - Ректифицированный, одного калибра.

*** JUNGLE** 120x278 cm . 47²/₈"x109⁷/₁₆" MATT RT

Range faces



A B

*** SPRING** 120x278 cm . 47²/₈"x109⁷/₁₆" MATT RT

Range faces

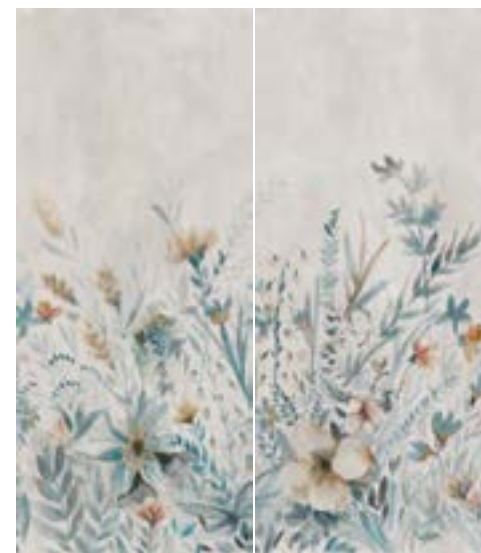

A B

*** PAMPA** 120x278 cm . 47²/₈"x109⁷/₁₆" MATT RT

Range faces



A B C

*** WATERCOLOR** 120x278 cm . 47²/₈"x109⁷/₁₆" MATT RT

Range faces



A B C

Le lastre potrebbero presentare minimi disallineamenti tra le grafiche in continuità: ciò è da intendersi come caratteristica intrinseca del prodotto.

There may be minor misalignments of continuous graphics: this is to be considered as an intrinsic feature of the product.

Die Platten könnten untereinander minimale Abweichungen in der Ausrichtung des graphischen Designs aufweisen: dies ist als ein charakteristisches Merkmal des Produktes zu betrachten.

Les dalles peuvent présenter de faibles écarts de graphiques en continuité: ceci est une caractéristique intrinsèque du produit.

У плит может наблюдаться минимальная нестыковка сплошного рисунка, которая должна считаться особенностью изделия.

* I decori con più grafiche sono inscatolati in maniera casuale; in caso di scelta di una o più facce specifiche rivolgersi agli uffici commerciali.

Decorations with several graphic patterns are boxed randomly; if you choose one or more specific sides of the product, please contact our sales department.

Dekore mit mehreren grafischen Varianten. Diese werden nach dem Zufallsprinzip verpackt. Sollten eine oder mehrere spezifische Varianten gewünscht werden, dann wende man sich bitte an unsere Vertriebsabteilung.

Les décors avec plusieurs motifs sont emballés de manière aléatoire; en cas de choix d'une ou plusieurs faces spécifiques, s'adresser aux bureaux commerciaux.

Декоры с множеством лиц упакованы в коробки в произвольном порядке. В случае выбора определенных лиц, пожалуйста, обращайтесь в офис продаж.

La gamma Gold_120x278

The Gold_120x278 range

GOLD MAGNOLIA 120x278 cm . 47²/₈"x109⁷/₁₆" LUCIDATO RT



Realizzato su **Anima Futura** - Unique Black lucidato.
Made on **Anima Futura** - Unique Black polished.
Fabriqué sur **Anima Futura** - Unique Black poli.
Realisiert bei **Anima Futura** – Unique Black glänzend.
Реализовано на основе **Anima Futura** – Unique Black с полированной отделкой.

GOLD WILLOW 120x278 cm . 47²/₈"x109⁷/₁₆" MATT RT

Range faces



A

B

Realizzato su **Prima** - Concrete.
Made on **Prima** - Concrete.
Fabriqué sur **Prima** - Concrete.
Realisiert bei **Prima** – Concrete.
Реализовано на основе **Prima** – Concrete.

La gamma Join_120x278

The Join_120x278 range

DECO 120x278 cm . 47²/₈"x109⁷/₁₆" MATT RT

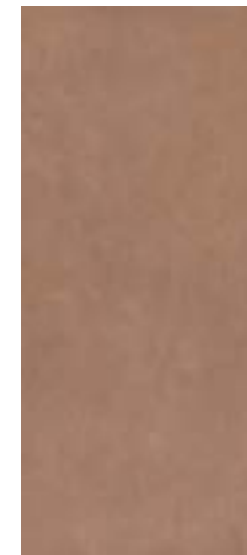

SPICE



VERVE

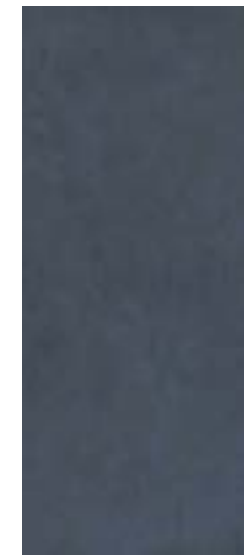

INK

REED 120x278 cm . 47²/₈"x109⁷/₁₆" MATT RT



I decori 120x278 Gold sono realizzati tramite applicazione da terzo fuoco di inchiostri a base oro. - The 120x278 Gold decorations are produced by third-firing application of gold-based inks. - Les décors 120x278 Gold sont réalisés par application au troisième feu d'encre à base d'or. - Die Dekore 120x278 Gold werden durch Auftragen von Golddruckfarben im Drittbrand hergestellt. - Декоры 120x278 Gold производятся методом третьего обжига с применением красок на золотой базе.

I decori di **Gold Magnolia**, **Gold Willow**, **Join** e **Misura Deco** in formato 120x278 sono realizzati tramite particolari applicazioni sulla superficie, successive alla cottura.

Per la pulizia ordinaria, Caesar sconsiglia l'utilizzo di prodotti abrasivi, che potrebbero danneggiare la superficie; per evitare opacizzazioni o graffiature, si consiglia di eseguire la pulizia con un panno morbido e detergenti a PH neutro.

In fase di posa del materiale, Caesar sconsiglia l'utilizzo di sistemi meccanici livellanti, che potrebbero causare danni alla superficie quando vengono rimossi. Prima di stuccare, si consiglia di proteggere la superficie nelle parti vicino al bordo con nastro adesivo per mascheratura; si raccomanda di utilizzare stucchi a base cementizia e non epossidica. Subito dopo la stuccatura, rimuovere gli eventuali residui con acqua e un panno morbido, senza l'utilizzo di spugne abrasive.

The 120x278 cm decors of the **Gold Magnolia**, **Gold Willow**, **Join** and **Misura Deco** collections were created using special surface applications after baking.

For ordinary cleaning, Caesar advises to avoid abrasive products that could damage the surface. Cleaning with a soft cloth and neutral PH products is recommended to avoid dulling or scratching. When laying the material, Caesar recommends not to use mechanical levelling systems, which could cause damage to the surface when removed. Before grouting, it is advised to protect the surface in the parts near the edge with masking tape. Cement-based, not epoxy-based, grouts must be used. Immediately after grouting, remove any residues with water and a soft cloth, without using abrasive sponges.

Les décors de **Gold Magnolia**, **Gold Willow**, **Join** et **Misura Deco** 120x278 ont été réalisés grâce à des applications spéciales sur la surface, successives à la cuisson.

Pour l'entretien ordinaire, Caesar déconseille d'utiliser des produits abrasifs, qui pourraient endommager la surface. Afin d'éviter opacification et rayures, il est conseillé d'effectuer le nettoyage à l'aide d'un chiffon souple et de produits au pH neutre. Lors de la pose du matériau, Caesar déconseille d'utiliser des systèmes mécaniques de nivellement, qui pourraient causer des dommages sur la surface lorsqu'on les retire. Avant le jointoiement, il est conseillé de protéger la surface aux endroits proches du bord à l'aide de ruban adhésif de masquage, et il est recommandé d'utiliser un mortier à base de ciment et non époxy. Tout de suite après le jointoiement, retirer les éventuels restes avec de l'eau et un chiffon souple, sans utiliser d'éponge abrasive.

Die Dekore im Format 120x278 cm aus der Serie **Gold Magnolia**, **Gold Willow**, **Join** und **Misura Deco** entstehen mit besonderen Applikationen nach dem Brennvorgang.

Für die normale Reinigung rät Caesar von Scheuermitteln ab, da diese die Oberfläche beschädigen könnten. Um matte Stellen und Kratzer zu vermeiden, sollten zur Reinigung nur weiche Tücher und Produkte mit neutralem pH-Wert verwendet werden. Bei der Verlegung des Materials rät Caesar von mechanischen Nivelliermitteln ab, da die Oberfläche bei ihrer Entfernung Schaden nehmen könnte. Vor dem Verfugen sollte die Oberfläche an den Kanten abgeklebt werden; wir empfehlen zementhaltige Fugenmörtel und keine Epoxidharz-Fugenmassen. Eventuelle Rückstände sind sofort nach dem Verfugen mit einem trockenen Tuch und Wasser zu entfernen. Keine Scheuerschwämme verwenden.

Декоры коллекции **Gold Magnolia**, **Gold Willow**, **Join** и **Misura Deco** в формате 120x278 реализованы, после обжига, методом специального поверхностного нанесения.

Компания Caesar рекомендует не использовать абразивные чистящие средства во избежание повреждения поверхности. Для предотвращения помутнения или появления царапин рекомендуется проводить очистку чистой ветошью и нейтральными моющими средствами. При укладке плитки компания Caesar не рекомендует использовать механические выравнивающие приспособления, способные повредить поверхность. Перед затиркой швов рекомендуется защитить края плитки малярным скотчем. Рекомендуется использовать затирочные составы на цементной, а не эпоксидной основе. После затирки швов необходимо удалить остатки материала мягкой ветошью и водой, не применяя абразивные губки.

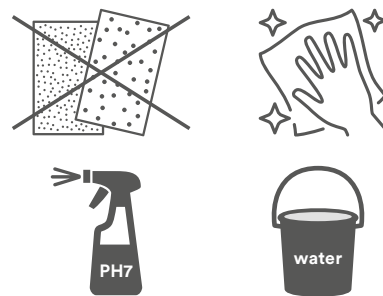

DUSK 120x278 cm . 47²/₈"x109⁷/₁₆" MATT RT

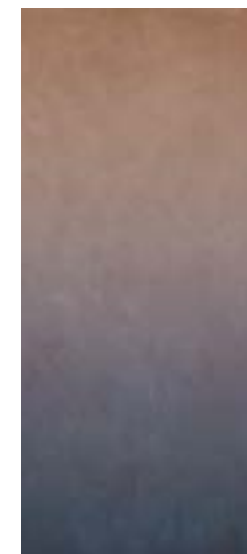

SPICE



VERVE

HOOP 120x278 cm . 47²/₈"x109⁷/₁₆" MATT RT



A



B

Solo per rivestimento. - Only for wall application. - Exclusivement pour revêtement mural. - Nur als Wandverkleidung geeignet. - Только для облицовки.

RT Rettificato, quadrato, monocalibro. - Rectified, squared, one caliber. - Rectifié, mis d'equerre et monocalibre. - Rektifiziert, rechtwinkling und Ein kaliber. - Ректифицированный, одного калибра.

Misura Deco - Express yourself

Misura Deco offre un servizio completamente customizzato, trasportando qualsiasi idea decorativa sulle lastre. È un aspetto di vitale importanza per il mondo del progetto, una chiave vincente per destinazioni come grandi progetti contract, catene di hotellerie o retail.

Misura Deco offers a fully customised service, translating any decorative idea onto slabs. This is very important to the design world, a winning concept for large-scale contract projects, such as hotel or retail chains.

Misura Deco offre un service complètement personnalisé, transposant ainsi toutes les idées de décoration sur les dalles. Il s'agit d'un aspect d'une importance fondamentale pour le secteur de la conception, un atout pour des utilisations dans les grands projets immobiliers, les chaînes hôtelières ou les magasins.

Misura Deco bietet einen perfekten Personalisierungsservice, denn auf den Platten lässt sich jede Dekorationsidee umsetzen. Eine bahnbrechende Entwicklung für die Objektplanung und ein Mehrwert in Anwendungsbereichen in Contract-Großprojekten, Hotel- oder Einzelhandelsketten.

Помимо этого, Misura Deco предлагает полностью персонализированную услугу, которая заключается в воплощении на поверхности плит любой идеи по декорированию. Последний аспект имеет чрезвычайную важность для сферы дизайна и знаменует собой ключ к успеху для таких направлений, как крупноформатные проекты, продукт для сетей гостиничного бизнеса и розничных продаж.

| | |
|----------------------------------------------------------------------------------------------------------------------------------------------------------------------------------------------------------------------------------------------------------------------------------------------------------------------------------------------------------------------------------|-------------------------------------------------------------------------------------------------------------------------------------------------------------------------------------------------------------------------------------------------------------|
| <p>1</p>  <p>Hai un'idea per decorare il tuo progetto? Do you have a decorative idea for your next project? Vous avez une idée pour décorer votre projet ? Haben Sie eine bestimmte Idee für die Dekoration Ihres Projekts? У Вас есть идея, как декорировать свой проект?</p> | <p>2</p>  <p>Disegna Design it Dessinez-la Machen Sie eine Zeichnung Нарисуйте ее</p> |
| <p>3</p>  <p>Scegli la lastra di partenza Choose the starting slab Choisissez la dalle de départ Wählen Sie die Platte, die Sie dekorieren möchten Выберите базовую плитку</p> | <p>4</p>  <p>Al resto pensiamo noi We'll take care of the rest Nous nous chargeons de tout le reste Den Rest erledigen wir Остальное - наша забота</p> |

We shape your ideas

Con Misura Deco, ogni idea decorativa può diventare un suggestivo rivestimento. È sufficiente fornire a Caesar un file grafico in formato .psd con dimensione di 120x278 cm e risoluzione di 360 dpi, e scegliere il prodotto di partenza tra le lastre in gamma.

With Misura Deco, every decorative idea can be transformed into an appealing wall tile. Simply provide Caesar with a graphics file in .psd format, with 120x278 cm size and 360 DPI resolution, and select your favourite slab from the range.

Avec Misura Deco, chaque idée de décoration peut devenir un revêtement suggestif. Il suffit de fournir à Caesar un fichier graphique au format .psd d'une dimension de 120x278 cm et d'une résolution de 360 dpi ; en suite il faudra choisir le produit de départ parmi les dalles de la gamme.

Mit Misura Deco wird jede Dekoridee zu einem eindrucksvollen Wandbelag. Sie brauchen Caesar lediglich eine Grafikdatei in PSD-Format, Größe 120x278 cm und Auflösung 360 dpi zu schicken und zu entscheiden, welche Platte aus dem Produktangebot dekoriert werden soll.

Благодаря Misura Deco любая идея по декорированию может воплотиться в эффектной облицовке. Достаточно предоставить компании Caesar графический файл в формате .psd размером 120x278 см и разрешением 360 dpi и выбрать базовую плитку из линейки продукции.



Grafica coprente.
Full-coverage graphics.
Graphique couvrant.
Voll deckende Grafik.
Графика по всей поверхности плиты.



Grafica a sfondo trasparente.
Graphics on clear background.
Graphique avec fond transparent.
Grafik mit transparentem Hintergrund.
Графика на прозрачном фоне.

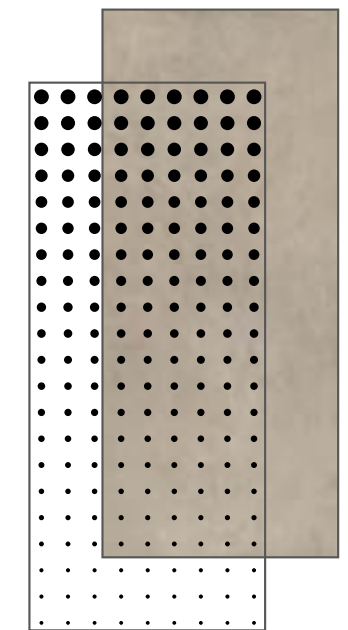

Motivo decorativo a sfondo trasparente.
Decorative pattern on clear background.
Motif décoratif avec fond transparent.
Dekormotiv mit transparentem Hintergrund.
Декоративный элемент на прозрачном фоне.

Applicazioni su lastre Caesar.

La personalizzazione può avvenire con idee decorative che interessano l'intera superficie delle lastre, oppure che la coprono in modo parziale. Questa tecnica offre la possibilità di applicare motivi grafici che arricchiscono l'estetica di qualsiasi prodotto della gamma di lastre 120x278 di Caesar; questo può riguardare anche loghi, icone o scritte, per creare un prodotto completamente customizzato e originale.

Caesar slab applications.

Customisation can come in the form of decorative ideas that can affect the entire surface of the slabs, or only parts of it. This technique makes possible to apply graphic patterns that embellish the styling of any product in the Caesar range of 120x278 slabs; this may also concern logos, icons or wording, to create a completely customized and unique product.

Applications sur dalles Caesar.

La personnalisation peut se faire avec des idées de décoration qui concernent toute la surface des dalles ou qui la couvrent seulement partiellement. Cette technique offre la possibilité d'appliquer des motifs graphiques qui enrichissent l'esthétique de n'importe quel produit de la gamme de dalles 120x278 de Caesar ; cela peut également concerner des logos, qu'il s'agisse d'images ou d'écritures, afin de créer un produit entièrement personnalisé et original.

Bedrucken der Caesar-Platten.

Die Personalisierung kann mit Dekoren erfolgen, die die Plattenoberfläche voll oder teilweise bedecken. Mit dieser Technik lassen sich grafische Motive aufbringen, die die Optik jeder Platte im Format 120x278 von Caesar bereichern. Das gilt auch für Logos, Symbole oder Beschriftungen. Damit entstehen perfekt personalisierte, originale Produkte.

Нанесение декора на плиты компании Caesar.

Персонализация может быть выполнена с помощью нанесения желаемого декора на всю поверхность плиты или на отдельные ее части. Эта техника дает возможность нанесения графических рисунков, которые украсят любой продукт из линейки крупноформатных плит размером 120x278 см компании Caesar; это могут быть также логотипы, знаки или надписи, что позволит создать полностью персонализированный и оригинальный продукт.



CARATTERISTICHE TECNICHE

TILE PERFORMANCE DATA - NOTES TECHNIQUES - TECHNISCHE AUSKÜNFTE - ТЕХНИЧЕСКАЯ ХАРАКТЕРИСТИКА

Classificazione secondo EN ISO 14411 ISO 13006 annesso G gruppo Bla con Ev ≤0,5% - Classification in accordance with EN ISO 14411 ISO 13006 annex G standards Bla with Ev ≤ 0,5% - Classification selon EN ISO 14411 ISO 13006 annexe G groupe Bla avec Ev ≤0,5% - Klassifizierung gemäß EN ISO 14411 ISO 13006 anlage G Gruppe Bla mit Ev ≤0,5% - Классификация в соответствии с EN ISO 14411 ISO 13006, приложение G, стандарт Bla, где Ev ≤0,5%

| | CARATTERISTICA TECNICA - TECHNICAL CHARACTERISTIC CARACTERISTIQUE TECHNIQUE - TECHNISCHE DATEN ТЕХНИЧЕСКАЯ ХАРАКТЕРИСТИКА | NORMA NORME NORME NORM HOFMA | VALORE * MEDIO "CAESAR" AVERAGE "CAESAR" VALUE * VALEUR * MOYEN "CAESAR" "CAESAR" DURCHSCHNITTSWERT * СРЕДНЕЕ ЗНАЧЕНИЕ "CAESAR" * | | | |
|--|-------------------------------------------------------------------------------------------------------------------------------------------------------------------------------------------------------------------------------------|------------------------------------------|-----------------------------------------------------------------------------------------------------------------------------------------------|------------------------------------------------------------------------------------------------------------------------------------------------------------------------------|------------------------------------------------------------------------------------------------------------------------------------------------------------------------------|-------------|
| | | | DECO 60x120 | DECO 120x278 | DECO 120x278 | |
| | | | Matt | Matt | Matt GL | Lucidato GL |
| | Dimensione - Size Dimension - Abmessungen - Размер | ISO 10545-2 | Conforme - In accordance Conforme - Erfüllt - Соответствует | Conforme - In accordance Conforme - Erfüllt - Соответствует | Conforme - In accordance Conforme - Erfüllt - Соответствует | |
| | Assorbimento d'acqua* - Water absorption* Absorption d'eau* - Wasseraufnahme* - % Поглощения воды* | ISO 10545-3 | ≤ 0,1% | ≤ 0,1% | ≤ 0,1% | |
| | Resistenza alla flessione* - Bending strength* Résistance à la flexion* - Biegezugfestigkeit* - Упругость* | ISO 10545-4 | Conforme - In accordance Conforme - Erfüllt - Соответствует | Conforme - In accordance Conforme - Erfüllt - Соответствует | Conforme - In accordance Conforme - Erfüllt - Соответствует | |
| | Resistenza all'urto - Impact resistance Résistance au choc - Schlagfestigkeit - Ударопрочность | ISO 10545-5 | ≥ 0,80 | ≥ 0,80 | ≥ 0,80 | |
| | Resistenza all'abrasione profonda* - Deep scratch resistance* Résistance à l'abrasion profonde* - Widerstand gegen Tiefverschleiß* Устойчивость к глубокому истиранию* | ISO 10545-6 | - | Conforme - In accordance Conforme - Erfüllt - Соответствует | Conforme - In accordance Conforme - Erfüllt - Соответствует | |
| | Coefficiente di dilatazione termica lineare* - Thermal linear expansion coefficient* Coefficient de dilatation thermique linéaire* - Koeffizient der linearen thermischen Dehnung* - Коэффициент линейного теплового расширения* | ISO 10545-8 | ≈ 7 (10 ⁻⁶ °C ⁻¹) | ≈ 7 (10 ⁻⁶ °C ⁻¹) | ≈ 7 (10 ⁻⁶ °C ⁻¹) | |
| | Resistenza al cavillo - Cracking resistance Résistance aux craquelures - Haarriß-Beständigkeit Устойчивость эмали к краquelору | ISO 10545-11 | - | Conforme - In accordance Conforme - Erfüllt - Соответствует | Conforme - In accordance Conforme - Erfüllt - Соответствует | |
| | Resistenza all'attacco chimico • - Resistance to chemical attack • Résistance à l'attaque chimique • - Beständigkeit gegen Chemikalien • Устойчивость к химическому воздействию • | ISO 10545-13 | Resistente - Resistant Résistante - Beständig - Стойкий | Resistente - Resistant Résistante - Beständig - Стойкий | Resistente - Resistant Résistante - Beständig - Стойкий | |
| | Resistenza alle macchie* - Resistance to stains* Résistance aux taches* - Fleckenbeständigkeit * Устойчивость к образованию пятен* | ISO 10545-14 | Pulibile - Cleanable Nettoyable - Leicht zu reinigen - Чистящийся | Pulibile - Cleanable Nettoyable - Leicht zu reinigen - Чистящийся | Pulibile - Cleanable Nettoyable - Leicht zu reinigen - Чистящийся | |
| | Resistenza all'abrasione superficiale - Surface abrasion resistance Résistance à l'abrasion superficielle - Widerstand gegen Oberflächenschleiß Сопротивление на изгиб и усилию на излом | EN ISO 10545-7 | - | Test disponibili in azienda Tests available at our company Tests disponibles en usine Prüfzeugnisse beim Werk erhältlich Протоколы испытаний хранятся в компании | Test disponibili in azienda Tests available at our company Tests disponibles en usine Prüfzeugnisse beim Werk erhältlich Протоколы испытаний хранятся в компании | |
| | Spessore nominale - Nominal Thickness Épaisseur nominal - Nominalstärke Номинальная толщина | | 9 mm 60x120 | 6 mm 120x278 | GOLD WILLOW 6 mm 120x278 JOIN DECO 6 mm 120x278 | |

* Valori medi riferiti agli ultimi due anni di produzione e relativi alla finitura naturale del prodotto - Average values referred to the last two years of production and related to the matt finish of the product - Valeurs moyennes des deux dernières années de production et relatifs à la finition naturelle du produit - Durchschnittswerte, die sich auf die letzten zwei Produktionsjahre beziehen und auf die matte Oberfläche - Средние значения относятся к последним двум годам производства и натуральной отделке поверхности

** Valori relativi alla finitura naturale del prodotto ed a test effettuati da laboratori esterni accreditati, disponibili in azienda; ci rendiamo disponibili alla verifica dell'eventuale lotto interessato all'acquisto. - As far as values relating to the matt finish of the product and to tests carried out by certified external laboratories whose results are available upon request at Headoffice, we are willing to check the lot you are interested in purchasing. - Valeurs se référant à la finition naturelle du produit selon des tests effectués par des laboratoires extérieurs accrédités et à la disposition de toute personne intéressée auprès de nos bureaux; nous sommes disponibles pour le contrôle de l'éventuel lot concerné par l'achat. - Werte bezogen auf das natürliche Produktfinish und in anerkannten externen Labors geprüft, im Unternehmen erhältlich; für eventuelle Prüfungen der zu erwerbenden Warenposten stehen wir gern zur Verfügung. - Значения, касающиеся натуральных характеристик изделий и тестов, выполненных внешними авторизованными лабораториями, имеются в компании. Мы готовы выполнить проверку партии товара, которую намереваетесь приобрести.

• Per prodotti chimici di uso domestico e additivi per piscina. - For domestic chemicals and swimming pool additives. - Pour produits chimiques à usage domestique et additifs pour piscines. - Für chemische Produkte für den Hausgebrauch und Schwimmbadzusätze. - Для бытовых химикатов и добавок для бассейнов.

Le tonalità dei campioni sono da considerarsi puramente indicative. - Tones of samples are indicative. - Les tonalités des échantillons sont purement indicatives. Die Farbtöne der Muster sind als rein indicativ zu betrachten. - Тона образцов ориентировочные.

Aextra20

Open your style

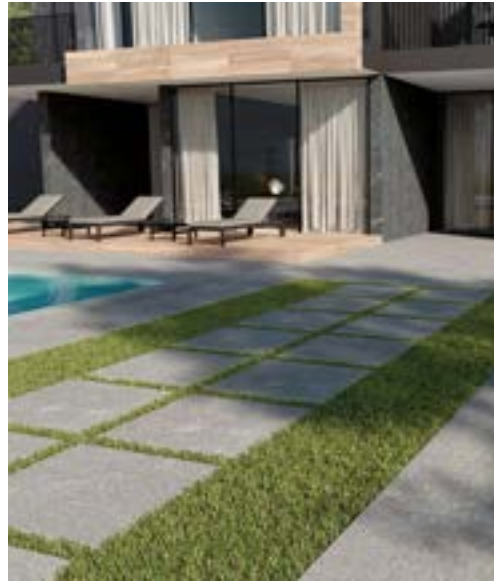

La linea in grès porcellanato spessorato Aextra20 è pensata per ampliare enormemente gli orizzonti dell'outdoor design.

The Aextra20 porcelain stoneware tile collection in extra thickness is designed to significantly broaden the horizons of outdoor design.

La gamme en grès cérame à épaisseur majorée Aextra20 a été conçue pour agrandir outre mesure les horizons de l'aménagement extérieur.

Die extrastarke Feinsteinzeuglinie Aextra20 wurde entwickelt, um die Grenzen des Outdoor Designs.

Линейка керамогранита увеличенной толщины Aextra20 задумана, чтобы расширить горизонты ландшафтного дизайна.



Info
Resources
Tools



Floor: PRIMA CONCRETE 80x80 AEXTRA20 RT R11 C
Wall: PRIMA AVIO 60x120 SOFT RT
Furniture: PRIMA AVIO COMP S 29x29 SOFT

Formati - Soluzioni

Sizes - Solutions

Posa su erba . Installation onto grass . Pose sur gazon .
Verlegung auf Rasen . Укладка на траву



Posa su ghiaia/sabbia . Installation onto gravel/sand . Posa sur
gravier/sable . Verlegung auf Kies/Sand . Укладка на гравий/песок



Posa sopraelevata . Raised installation . Pose surélevée .
Verlegung als Doppelboden . Укладка на опоры



Posa incollata . Installation with adhesives . Pose au mortier-colle .
Verlegung mit Kleber . Клеевая укладка



20 mm



120x120
47⁵/₈"x47⁵/₈"



60x120
23⁵/₈"x47⁵/₈"

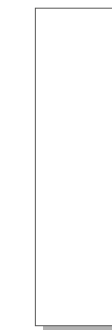

30x120
11⁵/₈"x47⁵/₈"



60x90
23⁵/₈"x35⁷/₁₆"

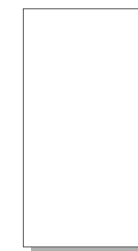

45x90
17¹¹/₁₆"x35⁷/₁₆"

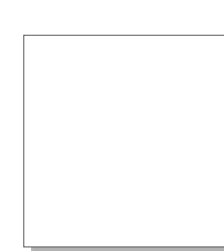

80x80
31¹/₈"x31¹/₈"

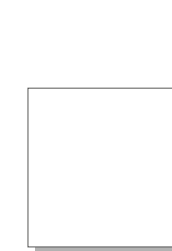

60x60
23⁵/₈"x23⁵/₈"

La gamma Metal Look

The Metal Look range

ALCHEMY TC.MINT 

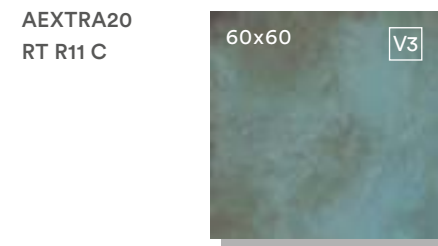

La gamma Stone Look

The Stone Look range

CORE ANCIENT  TEPHRA



E.MOTIONS SANDY WHITE URBAN GREY TRENDY BLACK

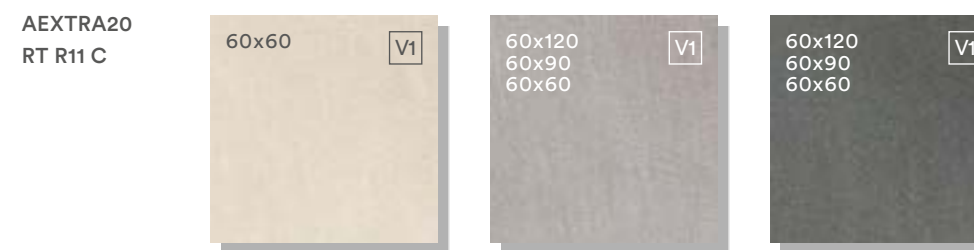

GRAUSTEIN



KEY_MOOD COTTON CANVAS SMOKE  AIR  SHADE 



TALE CLASSICO  CONTRO SILVER  CONTRO CCS SLAB KHAKI COKE



PORTRAITS COMBLANCHIEN FARO VERSILIA  KIRKBY 

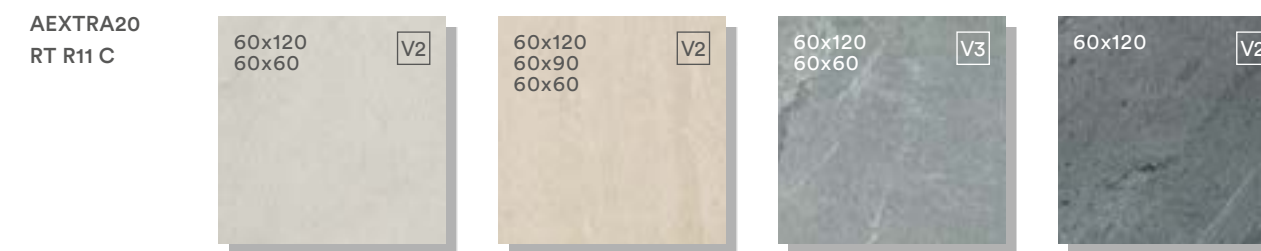

SHAPES OF ITALY BEOLA REALE ITRIA MONVISO  SESTRIERE  IULIA 



LAVIS  GARDENA 

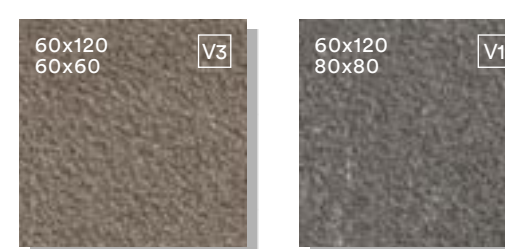











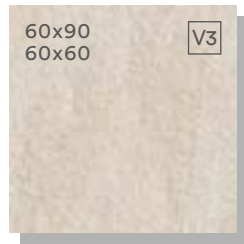



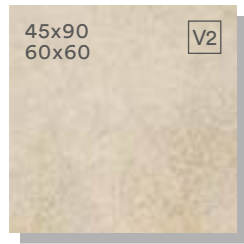

I prodotti Aextra20, in virtù di particolari processi produttivi, possono mostrare variazioni di tono anche significative rispetto al corrispondente prodotto in spessore tradizionale. - Aextra20 products, due to their special manufacturing processes, can feature considerable shade variations compared to similar products in standard thickness. - Les produits Aextra20, en vertu de processus de production particuliers, peuvent présenter des variations de couleur, même significatives, par rapport au produit correspondant dans l'épaisseur traditionnelle. - Die Aextra20 Produkte können aufgrund ihres speziellen Herstellungsverfahrens gegenüber dem entsprechenden Produkt in traditioneller Stärke Unterschiede, auch erhebliche, im Farbton aufweisen. - Изделия Aextra20 в силу технологических особенностей изготовления могут значительно отличаться по тону от соответствующих изделий традиционной толщины.

RT Rettificato, squadrato, monocalibro. - Rectified, squared, one caliber. - Rectifié, mis d'equerre et monocalibre. - Rektifiziert, rechtwinkelig und Ein kaliber. - Ректифицированный, одного калибра.

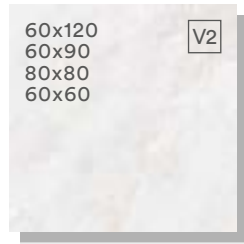
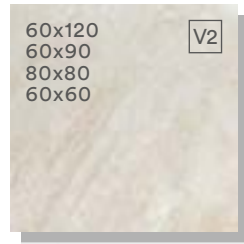
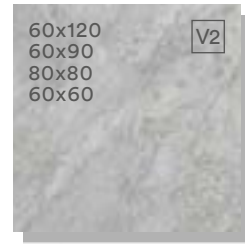
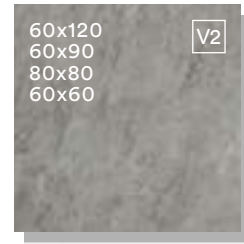
La gamma Quartz Look

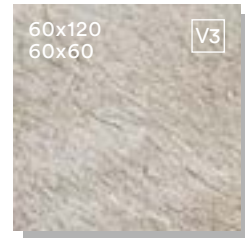

The Quartz Look range

| | | | | | |
|----------------------|-------------------------------------------------------------------------------------|-------------------------------------------------------------------------------------------|-------------------------------------------------------------------------------------------|---------------------------------------------------------------------------------------------|--------------------------------------------------------------------------------------------|
| CLASH | SOUL | ESSENCE  | NATURE  | | |
| AEXTRA20 RT R11 C |  |  |  | | |
| EIKON | GEA | AERAS  | TITANIO  | | |
| AEXTRA20 RT R11 C |  |  |  | | |
| QUARTZ ESSENCE | FLAKE | NEST | ROCKY  | BURNT  | WILD  |
| AEXTRA20 RT R11 C |  |  |  |  |  |
| ROXSTONES | WHITE QUARTZ | GOLDEN STONE | SILVER GRAY | | |
| AEXTRA20 RT R11 C |  |  |  | | |

RT Rettificato, squadrato, monocalibro. - Rectified, squared, one caliber. - Rectifié, mis d'équerre et monocalibre. - Rektifiziert, rechteckig und Ein kaliber. - Ректифицированный, одного калибра.

La gamma Concrete Look

The Concrete Look range

| | | | | | |
|----------------------|-------------------------------------------------------------------------------------------------|-----------------------------------------------------------------------------------------------|----------------------------------------------------------------------------------------------|----------------------------------------------------------------------------------------------|------------------------------------------------------------------------------------------|
| I.MAT | AREA  | SQUARE  | CUBE  | BUILT | YARD  |
| AEXTRA20 RT R11 C |  |  |  | AEXTRA20 RT R11 B |  |
| JOIN | WING  | LEVITY  | PLUME  | SIDEWALK  | |
| AEXTRA20 RT R11 C |  |  |  |  | |
| MATERICA | ANTRACITE  | POLVERE  | CORDA | | |
| AEXTRA20 RT R11 C |  |  |  | | |
| ONE | ROPE | CEMENT | GROUND  | | |
| AEXTRA20 RT R11 C |  |  |  | | |

I prodotti Aextra20, in virtù di particolari processi produttivi, possono mostrare variazioni di tono anche significative rispetto al corrispondente prodotto in spessore tradizionale. - Aextra20 products, due to their special manufacturing processes, can feature considerable shade variations compared to similar products in standard thickness. - Les produits Aextra20, en vertu de processus de production particuliers, peuvent présenter des variations de couleur, même significatives, par rapport au produit correspondant dans l'épaisseur traditionnelle. - Die Aextra20 Produkte können aufgrund ihres speziellen Herstellungsverfahrens gegenüber dem entsprechenden Produkt in traditioneller Stärke Unterschiede, auch erhebliche, im Farbton aufweisen. - Изделия Aextra20 в силу технологических особенностей изготовления могут значительно отличаться по тону от соответствующих изделий традиционной толщины.

La gamma Concrete Look

The Concrete Look range

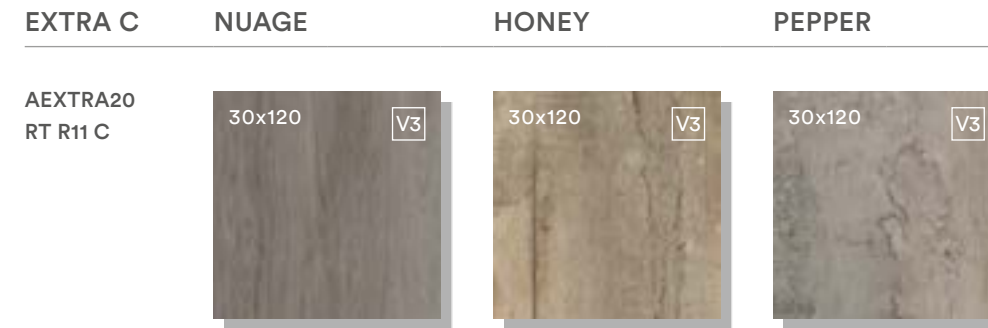
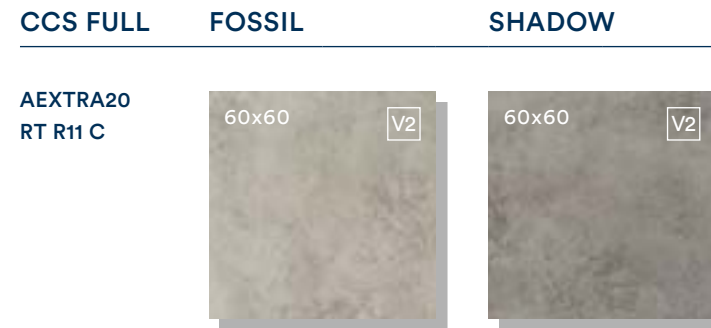

La gamma Wood Look

The Wood Look range

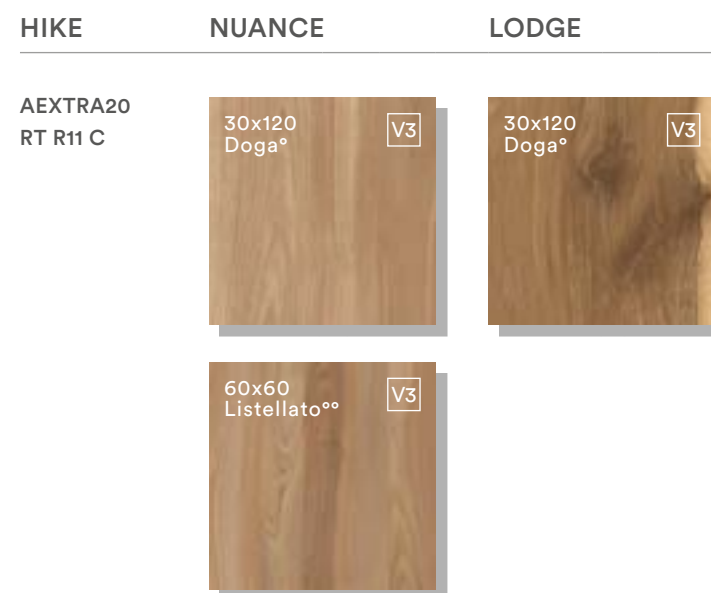
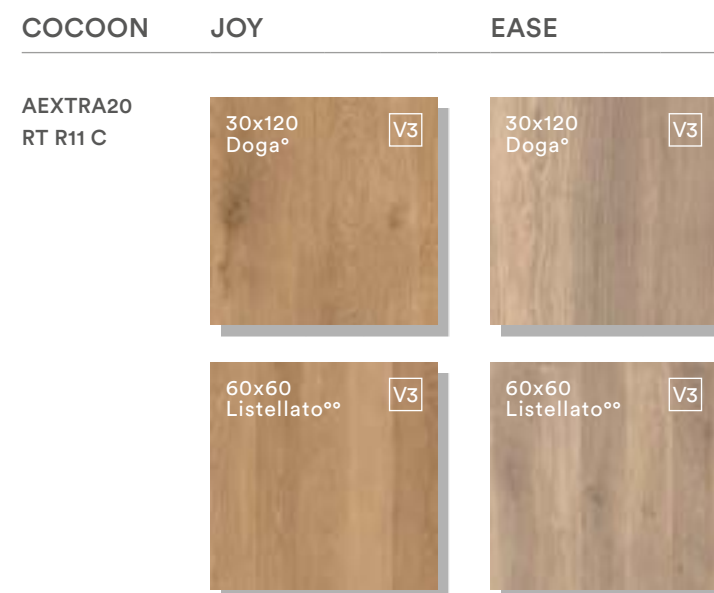
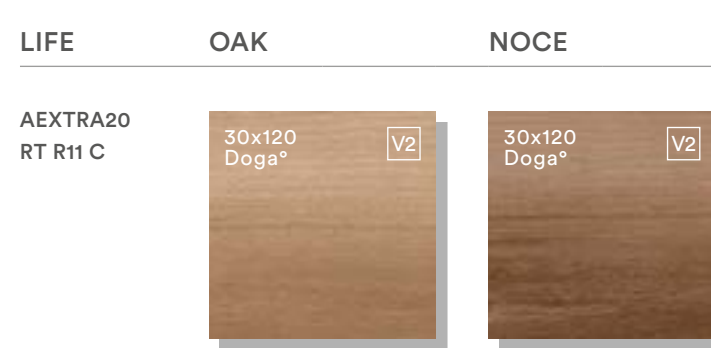

° Doga - Plank size - Lame - Diele - Доска
°° Listellato - Listel size - Multifrise - Leistenoptik - Эффект соединенных планок

Nei formati 80x80 e 60x60 l'estetica dei prodotti richiama doghe accostate tra loro o un look a cassettoni, mentre nel formato 30x120 viene riprodotta soltanto la texture del legno. - In the 80x80 and 60x60 sizes, the styling of the products recalls planks placed side-by-side or a coffered look, while the 30x120 size only reproduces the texture of natural wood. - Dans les formats 80x80 et 60x60 l'esthétique des produits rappelle des listels ou un aspect à caissons, tandis que dans le format 30x120 la texture du bois uniquement est reproduite. - In den Formaten 80x80 und 60x60 Verweist die Optik der Produkte auf Aneinandergelegte Dielen Oder auf Ein Kassettenmotiv, während im Format 30x120 die Holzstruktur ganz ächig reproduziert ist. - Эстетика изделий в форматах 80x80 и 60x60 напоминает друг к другу переклады или кессонный дизайн, воспроизводящих фактуру дерева; в формате 30x120 воспроизводится только фактура дерева.

RT Rettificato, squadrato, monocalibro. - Rectified, squared, one caliber. - Rectifié, mis d'équerre et monocalibre. - Rektifiziert, rechtwinkelig und Ein kaliber. - Ректифицированный, одного калибра.

I prodotti Aextra20, in virtù di particolari processi produttivi, possono mostrare variazioni di tono anche significative rispetto al corrispondente prodotto in spessore tradizionale. - Aextra20 products, due to their special manufacturing processes, can feature considerable shade variations compared to similar products in standard thickness. - Les produits Aextra20, en vertu de processus de production particuliers, peuvent présenter des variations de couleur, même significatives, par rapport au produit correspondant dans l'épaisseur traditionnelle. - Die Aextra20 Produkte können aufgrund ihres speziellen Herstellungsverfahrens gegenüber dem entsprechenden Produkt in traditioneller Stärke Unterschiede, auch erhebliche, im Farbton aufweisen. - Изделия Aextra20 в силу технологических особенностей изготовления могут значительно отличаться по тону от соответствующих изделий традиционной толщины.

Aextra modular design



Quartz Essence

Sulla gamma Quartz Essence Aextra20 Caesar propone quattro moduli multiformato, sfruttando le misure in gamma e introducendo due formati - 30x60 e 30x30 - dedicati a questo impiego.

On Quartz Essence Aextra20 range, Caesar offers four multiple size modules, exploiting the dimensions in the range and introducing two cutting sizes - 30x60 and 30x30 - dedicated to this particular usage.

Dans la gamme Quartz Essence Aextra20, Caesar propose quatre modules multi-formats, en exploitant les mesures et en ajoutant deux formats de coupe, 30x60 et 30x30, consacrés à cet usage.

Im Quartz Essence Aextra20-Sortiment bietet Caesar vier verschiedene, mehrformatige Module, die sich aus den bereits vorhandenen Formaten sowie zwei neuen, eigens für diese Verlegung eingeführten Schnittformaten 30x60 und 30x30 zusammensetzen.

В гамме Quartz Essence Aextra20 от Caesar представлены четыре мультиформатных модуля, использующих уже существующие форматы гаммы и включающих два новых формата 30x60 и 30x30, созданных специально в этих целях.

KIT MODULO / KIT MODULE: 1

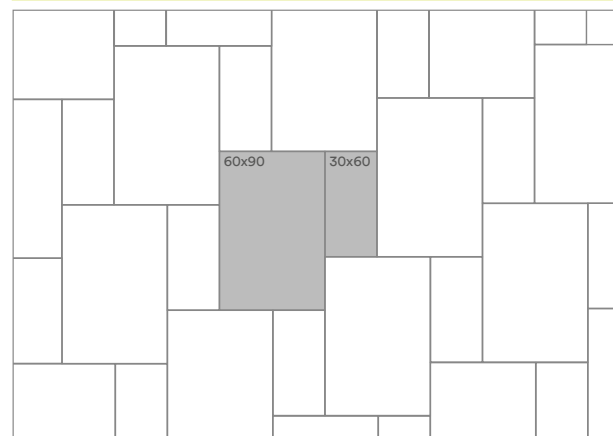

| Formato / Size | Scatole per kit / Boxes for each kit | Pezzi/ Pcs. | Mq/ Sqm. | Kg |
|-----------------------|--------------------------------------|-------------|----------|--------------|
| 60x90 cm | 1 | 2 | 1,08 | ~48,5 |
| 30x60 cm | 1 | 2 | 0,36 | ~16 |
| TOTALE / TOTAL | | 1,44 | | ~66,5 |

KIT MODULO / KIT MODULE: 2

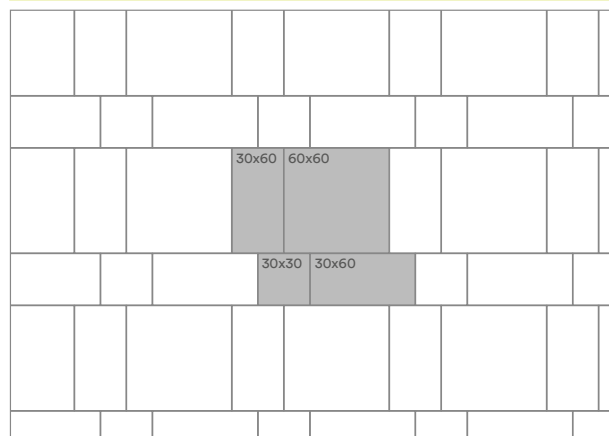

| Formato / Size | Scatole per kit / Boxes for each kit | Pezzi/ Pcs. | Mq/ Sqm. | Kg |
|-----------------------|--------------------------------------|-------------|----------|-------------|
| 60x90 cm | 2 | 4 | 1,44 | ~64 |
| 30x60 cm | 4 | 8 | 1,44 | ~64 |
| 30x30 cm | 1 | 4 | 0,36 | ~16 |
| TOTALE / TOTAL | | 3,24 | | ~144 |

KIT MODULO / KIT MODULE: 3

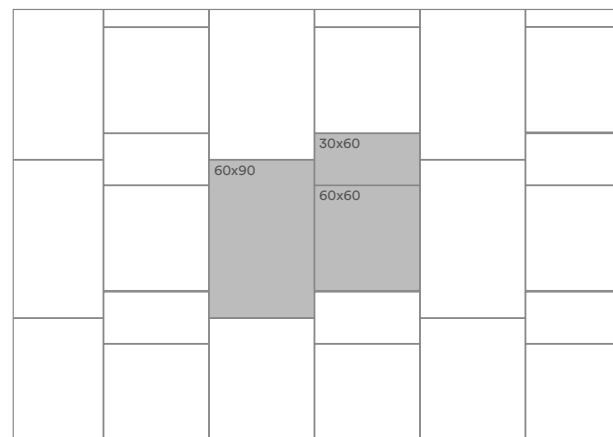

| Formato / Size | Scatole per kit / Boxes for each kit | Pezzi/ Pcs. | Mq/ Sqm. | Kg |
|-----------------------|--------------------------------------|-------------|----------|-------------|
| 60x90 cm | 2 | 4 | 2,16 | ~97 |
| 60x60 cm | 2 | 4 | 1,44 | ~64 |
| 30x60 cm | 1 | 4 | 0,72 | ~16 |
| TOTALE / TOTAL | | 4,32 | | ~177 |

KIT MODULO / KIT MODULE: 4

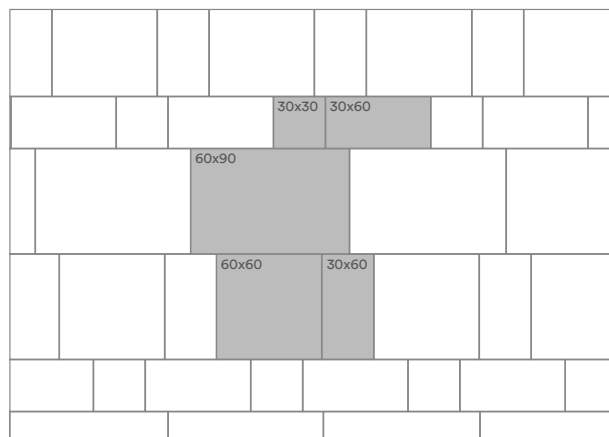

| Formato / Size | Scatole per kit / Boxes for each kit | Pezzi/ Pcs. | Mq/ Sqm. | Kg |
|-----------------------|--------------------------------------|-------------|----------|-------------|
| 60x90 cm | 2 | 4 | 2,16 | ~97 |
| 60x60 cm | 2 | 4 | 1,44 | ~64 |
| 30x60 cm | 4 | 8 | 1,44 | ~64 |
| 30x30 cm | 1 | 4 | 0,36 | ~16 |
| TOTALE / TOTAL | | 5,40 | | ~241 |



Floor: **ROCKY KIT MODULE 4 AEXTRA20 RT R11 C**
Furniture by CLOS: **ALCHEMY NAVY**

Fuga consigliata. - Recommenden joint. - Joint conseillé. - Empfohlene Fuge. - Рекомендуемый шов. : 4 mm

AEXTRA 20

60x90
23⁵/₈"x35⁷/₁₆"



60x60
23⁵/₈"x23⁵/₈"

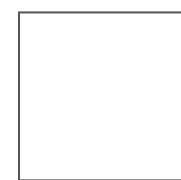

30x60 **
11³/₁₆"x23⁵/₈"



30x30 **
11³/₁₆"x11³/₁₆"



**** Formati disponibili esclusivamente nell'ambito delle pose modulari.**
These sizes are only available within multi-size layouts.

Le pose multiformato "Aextra Modular Design" si possono effettuare solamente con la modalità di posa incollata. Sono escluse le tipologie di posa sopraelevata e a secco. / "Aextra Modular Design" multi-size layouts can be only installed on floors with adhesives. The raised and dry installation methods are excluded. / Les poses multiformats "Aextra Modular Design" ne peuvent être réalisées qu'avec une pose collée. Les autres types de pose, surélevée et à sec, sont exclus. / Die Modulverlegung "Aextra Modular Design" ist ausschließlich in gebundener Bauweise möglich. Ausgeschlossen sind Verlegung auf Stelzlager und Trockenverlegung.

La variabilità di toni all'interno dello stesso modulo è da ritenersi una caratteristica intrinseca di questa tipologia di offerta, per enfatizzare la naturalezza del prodotto. Per ulteriori dettagli e le modalità di ordinazione, si prega di consultare il listino prezzi Quartz Essence.

The variability of tones within the same module should be deemed an intrinsic feature of this type of offering, to emphasise the naturalness of the product. For further details and for info about orders, please see Quartz Essence price list.

La variabilité des tons au sein d'un même module est une caractéristique intrinsèque de ce type de proposition, afin de souligner le caractère naturel du produit. Pour plus de détails et comment commander, veuillez consulter la liste de prix Quartz Essence.

Die Variabilität der Farbtöne innerhalb der Module selbst ist beabsichtigt und unterstreicht die Natürlichkeit des Produkts. Weitere Informationen und Bestellinformationen finden Sie in der Preisliste für Quarzessenzen.

Разнообразие оттенков в рамках одного модуля является неотъемлемой характеристикой этого предложения, подчеркивающего естественный вид изделия. Для получения дополнительной информации и того, как сделать заказ, обратитесь к прайс-листу Quartz Essence.

Aextra20

Disponibile nei colori che hanno fondo: - Available in colours offered in the: - Disponible dans les coloris disposant du format:
Lieferbar in allen Farben, die im Format verfügbar sind: - Поставляется в цветах, для которых предусмотрен формат
● 60x60 / ○ 80x80 / □ 45x90 / ✱ 60x90 / ◇ 30x120 / ▲ 60x120 / ✚ 120x120

AEXTRA20

Pezzi speciali

Trims pieces

Bordi - Edges - Bords - Ränder - Кромки

XSTEP

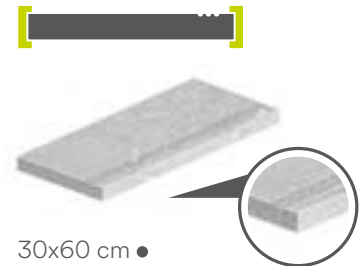

30x60 cm ●
30x80 cm ○
30x90 cm □ ✱
30x120 cm ▲ ◇ ✚

XGRIP

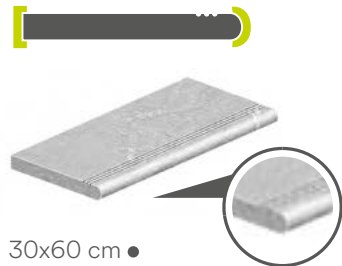

30x60 cm ●
30x80 cm ○
30x90 cm □ ✱
30x120 cm ▲ ◇ ✚

ROUND

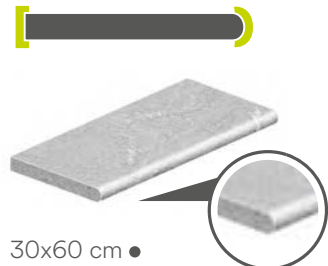

30x60 cm ●
30x80 cm ○
30x90 cm ✱
45x90 cm □
30x120 cm ▲ ◇ ✚



60x60 cm ●
80x80 cm ○

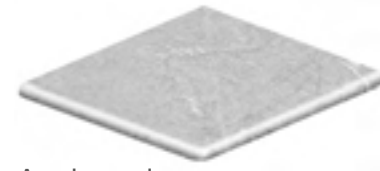

Angolo round
Corner - Angle - Ecke - Угол

60x60 cm ●
80x80 cm ○



Angolo round dx
Corner - Angle - Ecke - Угол

30x60 cm ●
30x80 cm ○
30x90 cm ✱
45x90 cm □
30x120 cm ▲ ◇ ✚



Angolo round sx
Corner - Angle - Ecke - Угол

30x60 cm ●
30x80 cm ○
30x90 cm ✱
45x90 cm □
30x120 cm ▲ ◇ ✚

XSOLID



30x60 cm ●
30x80 cm ○
30x90 cm ✱
60x90 cm ✱
45x90 cm □
30x120 cm ▲ ◇ ✚



DX

SX

Angolare interno
Internal corner - Angle intérieur
Innenecke - Внутренний угол

30x60 cm ●
30x80 cm ○
30x90 cm ✱
45x90 cm □
30x120 cm ▲ ◇ ✚



DX

SX

Angolare esterno
External corner - Angle extérieur
Außencke - Внешний угол

30x60 cm ●
30x80 cm ○
30x90 cm ✱
45x90 cm □
30x120 cm ▲ ◇ ✚



Angolo dx
Corner - Angle - Ecke - Угол

30x60 cm ●
30x80 cm ○
30x90 cm ✱
45x90 cm □
30x120 cm ▲ ◇ ✚



Angolo sx
Corner - Angle - Ecke - Угол

30x60 cm ●
30x80 cm ○
30x90 cm ✱
45x90 cm □
30x120 cm ▲ ◇ ✚

CURVE

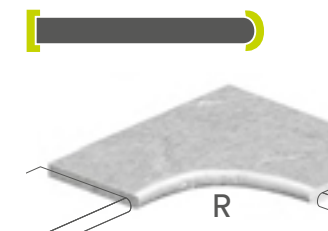

Angolare interno
Internal corner
Angle intérieur
Innenecke
Внутренний угол

60x60 cm ● ▲ ✱ ✚ R30 cm
80x80 cm ○ R30 cm

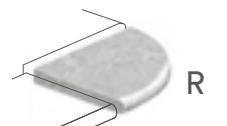

Angolare esterno
External corner
Angle extérieur
Außencke
Внешний угол

30x30 cm ● ▲ ✱ ✚ R30 cm

ALZATA

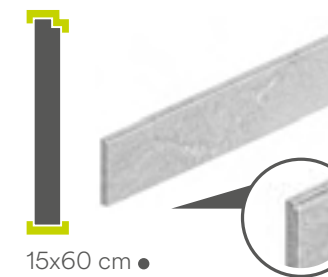

15x60 cm ●
15x80 cm ○
15x90 cm □ ✱
15x120 cm ▲ ◇ ✚

ARRONDI



Angolare interno
Internal corner
Angle intérieur
Innenecke
Внутренний угол

60x60 cm ● ▲ ✱ ✚ R30 cm
80x80 cm ○ R20,5 cm

STAIR



20x60 cm ●
20x80 cm ○
20x90 cm □ ✱
20x120 cm ▲ ◇ ✚

Angolo
Corner - Angle - Ecke - Угол



20x20 cm ✱ Vista posteriore



20x20 cm ✱ Vista anteriore

COMBO



15x20x60 cm ●
15x20x80 cm ○
15x20x90 cm □ ✱
15x20x120 cm ▲ ◇ ✚

IMBALLI - PACKAGING - CONDITIONNEMENT - VERPACKUNGS-EINHEITEN - УПАКОВКА

| Formato - Size - Format - Формат | | Scatola - Box - Boîte - Karton - Коробка | | | Pallet - Palette - Палета | | |
|----------------------------------|--------------------------------------------|------------------------------------------|------|--------|---------------------------|-------|----------|
| CM | INCHES | PZ | MQ | KG | SC | MQ | KG |
| 120x120 | 47 ^{1/16} "x47 ^{1/16} " | 1 | 1,44 | -65,50 | 20 | 28,80 | -1310,00 |
| 60x120 | 23 ^{5/8} "x47 ^{1/8} " | 1 | 0,72 | -33,35 | 35 | 25,20 | -1167,25 |
| 30x120 | 11 ^{9/16} "x47 ^{1/8} " | 2 | 0,72 | -33,35 | 36 | 25,92 | -1200,60 |
| 80x80 | 31 ^{1/8} "x31 ^{1/8} " | 1 | 0,64 | -29,70 | 42 | 26,88 | -1247,40 |
| 60x90 | 23 ^{5/8} "x35 ^{7/16} " | 2 | 1,08 | -48,50 | 24 | 25,92 | -1164,00 |
| 45x90 | 17 ^{11/16} "x35 ^{7/16} " | 2 | 0,81 | -36,00 | 27 | 21,87 | -972,00 |
| 60x60 | 23 ^{5/8} "x23 ^{5/8} " | 2 | 0,72 | -32,00 | 30 | 21,60 | -960,00 |

TOP

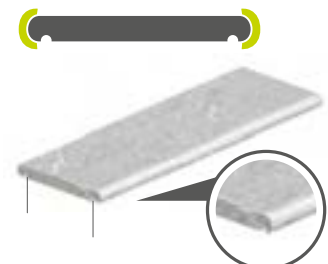

30x60 cm ●
30x80 cm ○
30x90 cm □ ✱
30x120 cm ▲ ◇ ✚

Pezzi speciali

Trims pieces

Griglie - Grids - Grilles - Gitter - Решётки

FLEXI_NEW



25x25 ★

Angolo
Corner - Angle - Ecke - Угол

Posa alternata
Alternated layout - Pose en caillebotis - Verlegung abwechselnd gedreht - Чередующаяся укладка



25x25 ★

Posa parallela
Parallel layout - Pose parallele - Verlegung parallel - Параллельная укладка



25x25 ★

Posa perpendicolare
Perpendicular layout - Pose perpendiculaire - Verlegung senkrecht - Перпендикулярная укладка



25x25 ★



SX

DX

Angolo
Corner - Angle - Ecke - Угол



SX

DX

Angolo
Corner - Angle - Ecke - Угол



SX

DX

Angolo
Corner - Angle - Ecke - Угол



FLEXI_NEW
POSA ALTERNATA - ALTERNATED LAYOUT



FLEXI_NEW
POSA PARALLELA - PARALLEL LAYOUT

BLADE

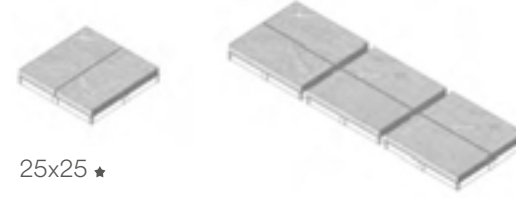

25x25 ★



SX

DX

Angolo
Corner - Angle - Ecke - Угол

STRIPE



20x60 ★



SX

DX

Angolo
Corner - Angle - Ecke - Угол

SHAPE



25x31 ★



BOLT



25x25 ★

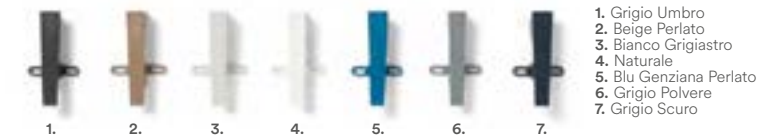

Le griglie Shape e Bolt sono formate da listelli ceramici incollati su supporto in materiale plastico. Per garantire la curvatura (griglia Shape) o l'inclinazione (griglia Bolt) dei tozzetti, tra questi vengono inseriti degli appositi cunei, che possono essere personalizzati scegliendo tra diversi colori.

The Shape and Bolt grids consist of ceramic listels glued onto a plastic support. To guarantee curving (Shape grid) or tilting (Bolt grid) of dots, special wedges are inserted between the latter. Wedges can be customized by choosing one of the available colours. - Les grilles Shape et Bolt sont formées de listels céramiques collés sur un support en matière plastique. Des cales spécifiques, pouvant être personnalisées par différentes couleurs, sont insérées entre les cabochons pour en garantir la courbure (grille Shape) ou l'inclinaison (grille Bolt). - Die Überlaufrinnen Shape und Bolt bestehen aus auf Kunststoffträger verklebten Keramikleisten. Zur Erzielung der Bogenform (Shape) bzw. der Neigung (Bolt) der Einleger werden Keile eingefügt, die je nach Wunsch in verschiedenen Farben zur Verfügung lieferbar sind. - Решетки Shape и Bolt состоят из керамических реек, наклеенных на пластиковую основу. Для обеспечения изгиба (решетка Shape) или наклона (griglia Bolt) элементов, между ними устанавливаются специальные клинья, цвет которых может быть подобран индивидуально.

★ Disponibile in tutti i colori Aextra20 - Vailable in the colors of Aextra20 range
Disponibles dans tous les coloris de la gamme Aextra20 - In allen Farben der Reihe Aextra20 erhältlich - Доступны во всех цветах гаммы Aextra20



BLADE



BOLT

Soluzioni per giardini e arredo pubblico

Solutions for gardens and public furniture

AEXTRABLOCK

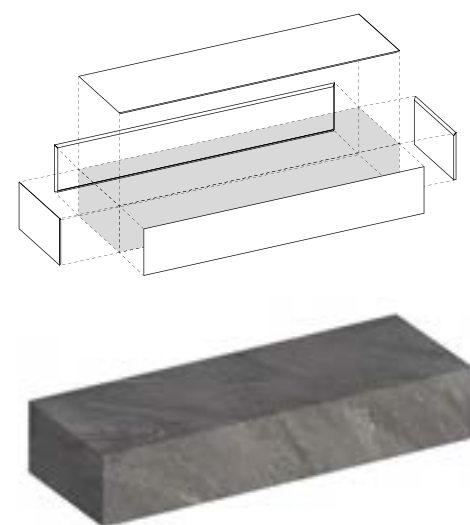

VANTAGGI:

- Elemento versatile, per diversi impieghi
- Rifinito nel dettaglio

ADVANTAGES:

- Versatile element, for various uses
- Finished in detail

AVANTAGES :

- Élément versatile, pour différentes utilisations
- Finition détaillée

VORTEILE:

- Vielseitig und für verschiedene Anwendungen geeignet
- Sorgfältig verarbeitet

ПРЕИМУЩЕСТВА:

- Универсальный элемент для различных целей
- Детальная отделка созданных специально в этих целях.

L'elemento AextraBlock permette di realizzare scale, muretti e terrazzamenti esterni su sottofondi in sabbia o terreno. si tratta di una struttura scatolare monoblocco in grès Aextra20: il taglio a 45 gradi delle piastrelle conferisce una totale continuità estetica alla superficie. Robusto e versatile, AextraBlock assicura tempi rapidi per l'installazione in cantiere.

The AextraBlock element allows the construction of stairs, walls and external terracing on sand or soil substrates. It is a one-piece box structure in Aextra20 stoneware: the 45-degree cut of the tiles gives the surface total aesthetic continuity. Robust and versatile, AextraBlock ensures quick installation on site.

L'élément AextraBlock permet de réaliser des escaliers, murets et terrassements d'extérieur sur des fonds en sable ou terre. Il s'agit d'une structure monobloc en grès Aextra20 : la coupe à 45 degrés des carreaux confère une continuité esthétique totale à la surface. Robuste et versatile, AextraBlock assure des temps d'installation rapides sur le chantier.

AextraBlock dient zur Ausführung von Außentreppen und Mauereinfassungen sowie zur Terrassierung auf Sand oder Erde. Es handelt sich um einen kastenförmigen, mit Aextra20-Feinsteinzeug verkleideten Block: der 45 Grad-Schnitt der Fliesen sorgt für perfekte Kontinuität des Belags. Das robuste und vielseitige AextraBlock ist schnell angebracht.

Элемент AextraBlock позволяет строить наружные лестницы, стены и террасы на бетонных, песчаных или грунтовых основаниях. Это моноблочная коробчатая конструкция из керамогранита Aextra20 с 45-градусным срезом плитки, обеспечивающим полную эстетическую непрерывность поверхности. Прочный и универсальный элемент AextraBlock обеспечивает быструю укладку на месте. Элемент представлен в цветах Aextra20, выполняемых по запросу для любого формата в ассортименте.



Applicabile su sottofondi in sabbia o terreno
Installation on sand or soil substrates

BLOOM



VANTAGGI:

- Facilità di installazione
- Elevata personalizzazione della parte estetica
- continuità visiva con il pavimento
- Applicazione a secco, senza collanti
- Nessuna lavorazione delle lastre

ADVANTAGES:

- Ease of installation
- High degree of aesthetic customisation
- Visual continuity with the floor
- Dry, adhesive-free application
- No slab processing

AVANTAGES :

- Facilité d'installation
- Grande personnalisation de la partie esthétique
- Continuité visuelle avec le sol
- Application à sec, sans adhésifs
- Aucun usinage des plaques

VORTEILE:

- Einfache Installation
- In hohem Maße personalisierbare Optik
- Optische Kontinuität mit dem Bodenbelag
- Anbringung im Trockenbau, ohne Kleber
- Keine Bearbeitung der Platten erforderlich

ПРЕИМУЩЕСТВА:

- Простота установки
- Широкие возможности персонализации эстетики
- Визуальная связность с полом
- Укладка сухим методом, без клея
- Отсутствие обработки плит

I moduli Bloom consentono la realizzazione di fioriere per giardini privati o per l'arredo pubblico. Le lastre vengono inserite in un telaio di metallo senza necessità di ulteriori lavorazioni, creando fioriere personalizzabili in base al proprio gusto oppure creando moduli di seduta con l'aggiunta di panchine. Bloom si presta ad una elevata personalizzazione ed a suggestivi effetti con il contesto esterno grazie all'ampiezza della gamma Aextra20. È consigliabile abbinare alle fioriere un sistema che assicuri la corretta irrigazione e il deflusso delle acque, come raffigurato nell'immagine esemplificativa.

Bloom modules allow the creation of planters for private gardens or public furniture. The slabs are inserted into a metal frame without the need for further processing, creating planters that can be customised to your taste or creating seating modules with the addition of benches. Bloom lends itself to a high degree of customisation and striking effects with the external context thanks to the breadth of the Aextra20 range. It is advisable to provide the planters with a system that ensures proper watering of the plants and regular water run-off, as shown in the sample image.

Les modules Bloom permettent de réaliser des jardinières pour les jardins particuliers ou l'ameublement public. Les dalles sont insérées dans un châssis en métal sans qu'aucune autre opération ne soit nécessaire, créant des jardinières personnalisables en fonction des goûts, ou des modules d'assise en ajoutant des bancs. Bloom se prête à une grande personnalisation et à des effets évocateurs pour l'extérieur grâce à l'ampleur de la gamme Aextra20. Il est conseillé d'associer aux jardinières un système qui assure le bon arrosage des plantes ainsi que le bon écoulement de l'eau, tel qu'illustré sur l'image.

Die Bloom-Module dienen zur Ausführung von Blumenkästen in Gärten und in öffentlichen Anlagen. Die Platten werden in einen Metallrahmen eingesetzt, ohne bearbeitet werden zu müssen, und bilden ganz nach Geschmack personalisierbare Blumenkästen, zwischen denen mit zusätzlichen Bankelementen auch Sitzflächen entstehen können. Bloom ist in hohem Maße personalisierbar und lässt sich dank der großen Auswahl des Aextra20-Sortiments effektiv in jeden Outdoor-Kontext integrieren. Es empfiehlt sich, mit den Blumenkästen auch ein geeignetes System für Bewässerung und Wasserablauf zu installieren, wie im abgebildeten Beispiel dargestellt.

Модули Bloom позволяют создавать вазоны для частных садов или мебели для мест общего пользования. Плиты устанавливаются в металлический каркас без необходимости дальнейшей обработки, что позволяет создавать вазоны или мебель для сидения по вашему вкусу. Богатый ассортимент Aextra20 Bloom предлагает широкие возможности персонализации и создания впечатляющих эффектов. Рекомендуется сочетать клумбы с системой, обеспечивающей надлежащий полив и отвод воды, как проиллюстрировано на примере.

Per maggiori informazioni tecniche e commerciali riguardo AextraDeck, AextraBlock e Bloom, rivolgersi ai nostri uffici commerciali.

For further commercial and technical information about AextraDeck, AextraBlock and Bloom, please refer to our sales offices.

Pour plus d'informations commerciales et techniques sur AextraDeck, AextraBlock et Bloom, veuillez vous adresser à nos bureaux commerciaux.

Für weitere kommerzielle und technische Informationen über AextraDeck, AextraBlock und Bloom wenden Sie sich bitte an unsere Vertriebsbüros.

Для получения дополнительной технической и коммерческой информации об AextraStufe и Bloom обращайтесь в наши офисы продаж.

Accessori per la soluzione sopraelevata

Accessories for raised installation

AEXTRADECK

Il sistema AextraDeck è una soluzione per pavimenti sopraelevati che ai supporti di tipo fisso e regolabile aggiunge una sottostruttura composta da travetti in alluminio; Questa caratteristica permette di realizzare superfici sopraelevate in tutta sicurezza, anche con grandi formati o schemi di posa sfalsati (si consulti la tabella per maggiori informazioni). Forte di elevata stabilità e resistenza, AextraDeck gode anche dei vantaggi della posa a secco, come la velocità, la praticità, e l'assenza di collanti o altri materiali per il fissaggio delle lastre.

The AextraDeck system is a solution for raised floors that adds a substructure composed of aluminium joists to the fixed and adjustable supports; this feature allows the creation of raised surfaces, guaranteeing the necessary safety even with large sizes or with offset installation patterns (see table for further information). With its high stability and strength, AextraDeck also enjoys the advantages of dry installation, such as speed, convenience, and the absence of adhesives or other materials for fixing the slabs.

Le système AextraDeck est une solution pour les sols surélevés qui comprend des supports fixes et réglables, ainsi qu'une sous-structure composée de baguettes en aluminium ; cette caractéristique permet de réaliser des surfaces surélevées tout en garantissant la sécurité nécessaire, même aux grands formats ou des schémas de pose décalés (consulter le tableau pour plus d'informations). Fort d'une grande stabilité et résistance, AextraDeck assure également les avantages de la pose à sec : rapidité, commodité, absence de produits adhésifs ou autres matériaux pour la fixation des dalles.

Das System AextraDeck ist eine Lösung für Doppelböden, bei der die festen bzw. höhenverstellbaren Träger um eine Unterstruktur aus Aluminiumstreben ergänzt werden. Diese zusätzliche Struktur dient zur Verlegung aufgestockter Bodenbeläge, die absolute Sicherheit bieten, auch mit Großformaten oder versetzten Verlegemustern (für weitere Informationen siehe die Tabelle). Das überaus stabile und belastbare AextraDeck besitzt des Weiteren alle Vorteile der Trockenverlegung: schnelle Ausführung, Funktionalität und Verlegung ohne Kleber oder andere Materialien zur Befestigung der Platten.

Система AextraDeck — это решение для фальшполов, которое к неподвижным и регулируемым опорам добавляет подструктуру, состоящую из алюминиевых балок. Эта функция позволяет безопасно создавать фальшполы, даже при больших форматах или ступенчатой схеме укладки (более подробную информацию см. в таблице). Обеспечивающая высокую стабильность и прочность система AextraDeck также пользуется преимуществами укладки сухим методом, такими как скорость, практичность и отсутствие клеев или других материалов для крепления плитки.

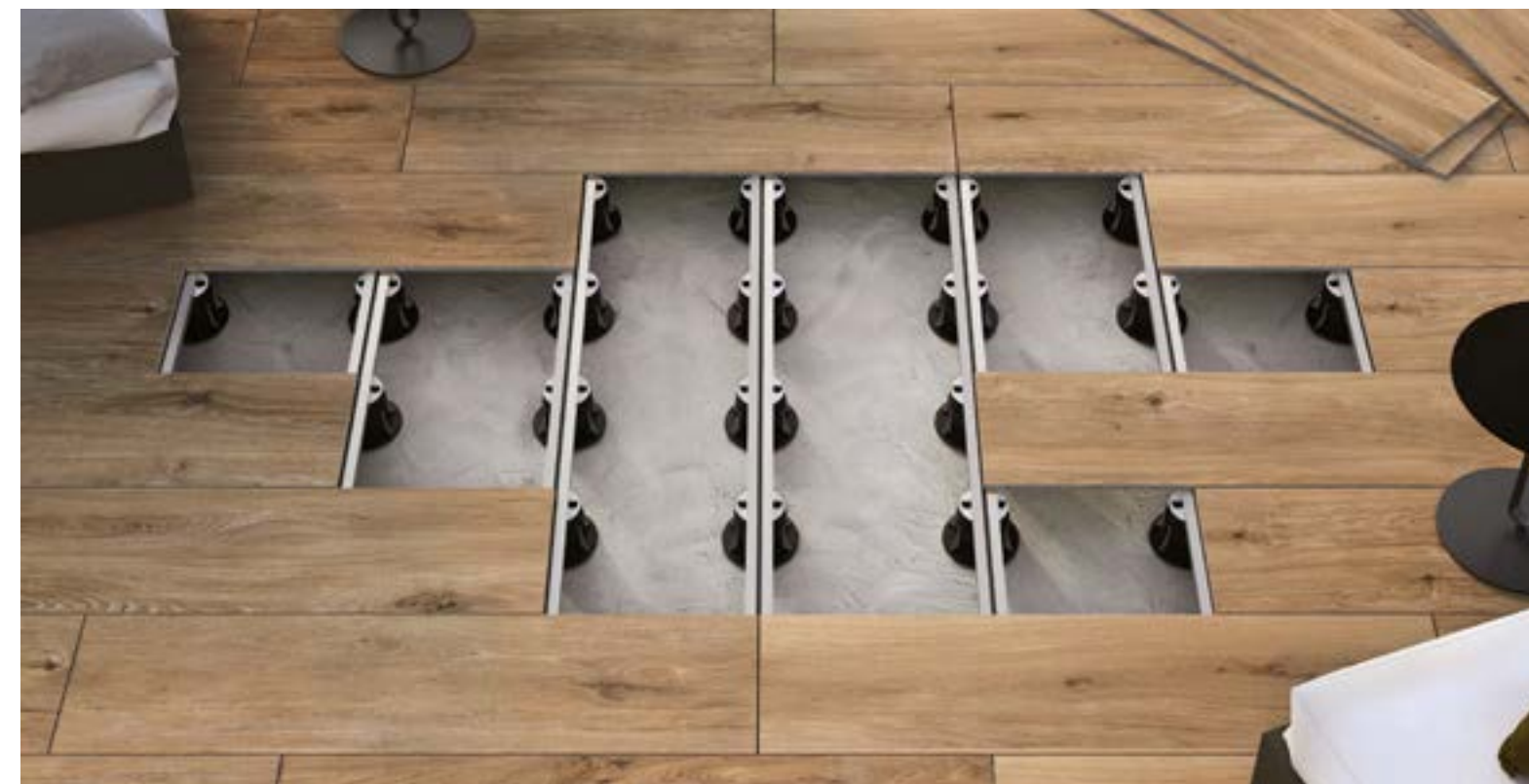

- VANTAGGI:**
- Sopraelevazione per tutti i formati
 - Schemi di posa sfalsati
 - Stabilità del piano di calpestio
 - Posa a secco
 - Veloce da posare







- ADVANTAGES:**
- Raised installation for all sizes
 - Offset installation patterns
 - Stable trampling surface
 - Dry installation
 - Quick to install

- AVANTAGES :**
- Surélévation pour tous les formats
 - Schémas de pose décalés
 - Stabilité du plan de piétinement
 - Pose à sec
 - Rapidité de pose

- VORTEILE:**
- Doppelbodenstruktur für alle Formate
 - Versetzte Verlegemuster
 - Stabile Trittläche
 - Trockenverlegung
 - Schnelle Verlegung

- ПРЕИМУЩЕСТВА:**
- Приподымание для всех форматов
 - Ступенчатые схемы укладки
 - Устойчивость фальшпола
 - Укладка сухим методом
 - Быстрая укладка

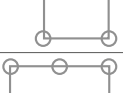
| ISTRUZIONI PER LA POSA SOPRAELEVATA - INSTRUCTIONS FOR RAISED FLOOR INSTALLATION - INSTRUCTIONS POUR LA POSE SURÉLEVÉE ANWEISUNGEN FÜR DIE DOPPELBODENVERLEGUNG - УКАЗАНИЯ ПО УКЛАДКЕ В ВИДЕ ФАЛЬШПОЛА | | | |
|-----------------------------------------------------------------------------------------------------------------------------------------------------------------------------------------------------------|---------------------------------------------------------------------------------------------------------------------------------------------------------------------------------------------------------------------------------------------------------------------------------------------------------------------------------------------------------------------------------------------------------------------------------------------------------------------------------------------------------------------------------------------------------------------------------------------|-------------------------------------------------------------------------------------------------------------------------------------------------------------------------------------------------------------------------------------------------------------------------------------------------------------------------------------------------------------------------------------------------------------------------------------------------------------------------------------------------------------------------------------------------------------------------------------------------------------------------------------------------------------------------------------------------------------------------------------------------------------------------------------------------------------------------------------------------------------------------------------------------------------------------------------------------------------------------------------------------------------------------------------------------------------------------------------------------------------------|------------------------------------------------------------------------------------------------------------------------------------------------------------------------------------------------------------------------------------------------------------------------------------------------------------------------------------------------------------------------------------------------------------------------------------------------------------------------------------------------------------------------------------------------------------------------------------------------------------------------------------------------------------------------------------------------------------|
| Formato Size Format Format Формат | Altezza della sopraelevazione - Raise of the foot plan - Hauteur de la surélévation - Höhe des Doppelbodens - Высота монтажа | | |
| | Fino a 2 cm Up to - Jusqu'à Bis zu - До | Tra 2 e 10 cm From 2 to 10 cm Entre 2 et 10 cm 2 bis 10 cm От 2 до 10 см | Tra 10 e 30 cm From 10 to 30 cm Entre 10 et 30 cm 10 bis 30 cm От 10 до 30 см |
|  60x60 | 4 SUPPORTI/LASTRA (3,4 SUPPORTI/MQ) 4 supports/slab (3,4 supports/mq) 4 supports / dalle (3,4 supports / m²) 4 Träger/Platte (3,4 Träger/qm) 4 опор/плитку (опоры/кв.м) | | 4 SUPPORTI/LASTRA (3,4 SUPPORTI/MQ) + APPLICAZIONE DOPPIA RETE IN FIBRA DI VETRO OPPURE AEXTRADECK + APPLICAZIONE DOPPIA RETE IN FIBRA DI VETRO 4 supports/slab (3,4 supports/mq) + application of a double glass fibre net or AextraDeck + application of a double glass fibre net 4 supports / dalle (3,4 supports / m²) + application double treillis en fibre de verre ou AextraDeck + application double treillis en fibre de verre 4 Träger/Platte (3,4 Träger/qm) + Aufkleben eines doppelten GFK-Netzes oder AextraDeck + Aufkleben eines doppelten GFK-Netzes 4 опоры/плитку (3,4 опоры/кв.м) + двойная стекловолоконная сетка или AextraDeck + двойная стекловолоконная сетка |
|  60x120 45x90 | 6 SUPPORTI/LASTRA (FORMATO 60x120: 3,4 SUPPORTI/MQ) (FORMATO 45x90: 6 SUPPORTI/MQ) (FORMATO 60x90: 4,5 SUPPORTI/MQ) 6 supports/slab (Size 60x120: 3,4 supports/mq) (Size 45x90: 6 supports/mq) (Size 60x90: 4,5 supports/mq) 6 supports / dalle (Format 60x120: 3,4 supports / m²) (Format 45x90: 6 supports / m²) (Format 60x90: 4,5 supports / m²) 6 Träger/Platte (Format 60x120: 3,4 Träger/qm) (Format 45x90: 6 Träger/qm) (Format 60x90: 4,5 Träger/qm) 6 опоры/плитку (формат 60x120: 3,4 опоры/кв.м) (формат 45x90: 6 опоры/кв.м) (формат 60x90: 4,5 опоры/кв.м) | 6 SUPPORTI/LASTRA (FORMATO 60x120: 3,4 SUPPORTI/MQ) (FORMATO 45x90: 6 SUPPORTI/MQ) (FORMATO 60x90: 4,5 SUPPORTI/MQ) + APPLICAZIONE DOPPIA RETE IN FIBRA DI VETRO OPPURE AEXTRADECK + APPLICAZIONE DOPPIA RETE IN FIBRA DI VETRO 6 supports/slab (Size 60x120: 3,4 supports/mq) (Size 45x90: 6 supports/mq) (Size 60x90: 4,5 supports/mq) + application of a double glass fibre net or AextraDeck + application of a double glass fibre net 6 supports / dalle (Format 60x120: 3,4 supports / m²) (Format 45x90: 6 supports / m²) (Format 60x90: 4,5 supports / m²) + application double treillis en fibre de verre ou AextraDeck + application double treillis en fibre de verre 6 Träger/Platte (Format 60x120: 3,4 Träger/qm) (Format 45x90: 6 Träger/qm) (Format 60x90: 4,5 Träger/qm) + Aufkleben eines doppelten GFK-Netzes AextraDeck oder AextraDeck + Aufkleben eines doppelten GFK-Netzes 6 опоры/плитку (формат 60x120: 3,4 опоры/кв.м) (формат 45x90: 6 опоры/кв.м) (формат 60x90: 4,5 опоры/кв.м) + двойная стекловолоконная сетка или AextraDeck + двойная стекловолоконная сетка | |
|  30x120 | 6 SUPPORTI/LASTRA (7 SUPPORTI/MQ) 6 supports/slab (7 supports/mq) 6 supports / dalle (7 supports / m²) 6 Träger/Platte (7 Träger/qm) 6 опоры/плитку (7 опоры/кв.м) | | 6 SUPPORTI/LASTRA (7 SUPPORTI/MQ) + APPLICAZIONE DOPPIA RETE IN FIBRA DI VETRO OPPURE AEXTRADECK + APPLICAZIONE DOPPIA RETE IN FIBRA DI VETRO 6 supports/slab (7 supports/mq) + application of a double glass fibre net or AextraDeck + application of a double glass fibre net 6 supports / dalle (7 supports / m²) + application double treillis en fibre de verre ou AextraDeck + application double treillis en fibre de verre 6 Träger/Platte (7 Träger/qm) + Aufkleben eines doppelten GFK-Netzes oder AextraDeck + Aufkleben eines doppelten GFK-Netzes 6 опоры/плитку (7 опоры/кв.м) + двойная стекловолоконная сетка или AextraDeck + двойная стекловолоконная сетка |
|  80x80 | 4 SUPPORTI/LASTRA (2,4 SUPPORTI/MQ) 4 supports/slab (2,4 supports/mq) 4 supports / dalle (2,4 supports / m²) 4 Träger/Platte (2,4 Träger/qm) 4 опоры/плитку (2,4 опоры/кв.м) | | AEXTRADECK + APPLICAZIONE DOPPIA RETE IN FIBRA DI VETRO AextraDeck + application of a double glass fibre net AextraDeck + application double treillis en fibre de verre AextraDeck + Aufkleben eines doppelten GFK-Netzes AextraDeck + двойная стекловолоконная сетка |
|  120x120 | 8 SUPPORTI/LASTRA (2,7 SUPPORTI/MQ) 8 supports/slab (2,7 supports/mq) 8 supports / dalle (2,7 supports / m²) 8 Träger/Platte (2,7 Träger/qm) 8 опоры/плитку (2,7 опоры/кв.м) | | AEXTRADECK + APPLICAZIONE DOPPIA RETE IN FIBRA DI VETRO AextraDeck + application of a double glass fibre net AextraDeck + application double treillis en fibre de verre AextraDeck + Aufkleben eines doppelten GFK-Netzes AextraDeck + двойная стекловолоконная сетка |

| INSTRUCTIONS FOR RAISED FLOOR INSTALLATION - USA - CANADA - OCEANIA INSTRUCTIONS POUR LA POSE SURÉLEVÉE - ETATS UNIS - CANADA - OCÉANIE | | | |
|--------------------------------------------------------------------------------------------------------------------------------------------|---------------------------------------------------------------------------------------|--------------------------------------------------------------------------------------------------------------------------------------------------------------------------------|--------------------------------------------------------------------------------------------------------------------------------|
|  | | Raise of the foot plan - Hauteur de la surélévation | |
| Size - Format | | Up to 3/4 inch - Jusqu'à 3/4 pouces (2cm) | Above 3/4 inch - Au-delà de 3/4 pouces (2cm) |
| Size 23 5/8" x 23 5/8" (60x60cm) |  | 4 supports/slab (0,32 supports/sqf - 3,4 supports/mq) 4 supports / dalle (0,32 supports /sqf - 3,4 supports/m²) | Please contact Ceramiche Caesar (Caesartech dept.) Veuillez consulter Ceramiche Caesar (Service Caesartech) |
| Size 23 5/8" x 47 2/8" (60x120cm) |  | 6 supports/slab (Size 60x120: 0,32 supports/sqf - 3,4 supports/mq) (Size 45x90: 0,56 supports/sqf - 6 supports/mq) (Size 60x90: 0,42 supports/sqf - 4,5 supports/mq) | |
| Size 17 11/16" x 35 7/16" (45x90cm) |  | | |
| Size 23 5/8" x 35 7/16" (60x90cm) |  | 6 supports/dalle (Format 60x120: 0,32 supports /sqf - 3,4 supports/m²) (Format 45x90: 0,56 supports /sqf - 6 supports/m²) (Format 60x90: 0,42 supports /sqf - 4,5 supports/m²) | |
| Size 11 13/16" x 47 2/8" (30x120cm) |  | 6 supports/slab (0,65 supports/sqf - 7 supports/mq) 6 supports/dalle (0,65 supports/sqf - 7 supports/m²) | |
| Size 31 4/8" x 31 4/8" (80x80cm) |  | 4 supports/slab (2,4 supports/sqf - 2,4 supports/mq) 4 supports/dalle (2,4 supports /sqf - 2,4 supports/m²) | |
| Size 47 2/8" x 47 2/8" (120x120cm) |  | 8 supports/slab (2,7 supports/sqf - 2,7 supports/mq) 8 supports/dalle (2,7 supports /sqf - 2,7 supports/m²) | |



Floor: SHAPES OF ITALY IULIA 120x120 AEXTRA20 RT R11 C

CARATTERISTICHE TECNICHE

TILE PERFORMANCE DATA - NOTES TECHNIQUES - TECHNISCHE AUSKÜNFTE - ТЕХНИЧЕСКАЯ ХАРАКТЕРИСТИКА

Classificazione secondo EN ISO 14411 ISO 13006 annesso G gruppo Bla con Ev ≤0,5 % - Classification in accordance with EN ISO 14411 ISO 13006 annex G standards Bla with Ev ≤ 0,5% - Classification selon EN ISO 14411 ISO 13006 annexe G groupe Bla avec Ev ≤0,5% - Klassifizierung gemäß EN ISO 14411 ISO 13006 anlage G Gruppe Bla mit Ev ≤0,5% - Классификация в соответствии с EN ISO 14411 ISO 13006, приложение G, стандарт Bla, где Ev ≤0,5%

| | CARATTERISTICA TECNICA TECHNICAL CHARACTERISTIC CARACTERISTIQUE TECHNIQUE TECHNISCHE DATEN ТЕХНИЧЕСКАЯ ХАРАКТЕРИСТИКА | METODO DI PROVA TESTS METHOD METHODE D'ESSAI TESTMETHODE МЕТОДИСПЫТАНИЯ | VALORE * MEDIO "CAESAR" AVERAGE "CAESAR" VALUE * VALEUR * MOYEN "CAESAR" "CAESAR" DURCHSCHNITTSWERT *СРЕДНЕЕ ЗНАЧЕНИЕ "CAESAR" * | AEXTRA20 OPEN YOUR STYLE | | | | | | |
|--|--------------------------------------------------------------------------------------------------------------------------------------------------------------------------------------------------------------------------------------------|-------------------------------------------------------------------------------------|------------------------------------------------------------------------------------------------------------------------------------------------------------------------------------------------------------------------------------------------------------------------------------------------|----------------------------------------------------|--------------------------------------------------------------------------------------------------------------------------------------------------------------------------------------------------------------------------------------------|----------|----------|----------|----------|--------|
| | Dimensione - Size Dimension - Abmessungen - Размер | ISO 10545-2 | Conforme - In accordance Conforme - Erfüllt - Соответствует | | | | | | | |
| | Assorbimento d'acqua* - Water absorption* Absorption d'eau* - Wasseraufnahme* - Поглощения воды* | ISO 10545-3 | ≤ 0,1% | | | | | | | |
| | Resistenza alla flessione* - Bending strength* Résistance à la flexion* - Biegezugfestigkeit* - Упругость* | ISO 10545-4 | Non applicabile a piastrelle con una forza di rottura Not applicable to tiles with a breaking strength N'est pas applicable aux carreaux avec une charge de rupture Nicht anwendbar bei Fliesen mit einer Bruchlast Не применяется в отношении плиток с прочностью на изрыв | ≥ 3000 N | ≥ 3000 N | ≥ 3000 N | ≥ 3000 N | ≥ 3000 N | ≥ 3000 N | |
| | Sforzo di rottura (S) - Breaking strength Charge de rupture - Bruchlast - Разрушающее усилие | ISO 10545-4 | > 10.000 N | | | | | | | |
| | Resistenza all'abrasione profonda* - Deep scratch resistance* Résistance à l'abrasion profonde* - Widerstand gegen Tiefenverschleiß* Устойчивость глубокому истиранию* | ISO 10545-6 | Conforme - In accordance Conforme - Erfüllt - Соответствует | | | | | | | |
| | Coefficiente di dilatazione termica lineare* - Thermal linear expansion coefficient* Coefficient de dilatation thermique linéaire* - Koeffizient der linearen thermischen Dehnung* - Коэффициент линейного теплового расширения* | ISO 10545-8 | ≈ 7 (10 ⁻⁶ °C ⁻¹) | | | | | | | |
| | Resistenza agli sbalzi termici* - Thermal shock resistance* Résistance aux écarts de température* - Temperaturwechsel Beständigkeit* Устойчивость к тепловому перепаду* | ISO 10545-9 | Resistente - Resistant Résistante - Beständig - Стойкий | | | | | | | |
| | Dilatazione all'umidità* - Expansion in humidity* Dilatation à l'humidité* - Feuchtigkeitsausdehnung* Расширение в условиях влажности* | ISO 10545-10 | ≤ 0,1 (mm/m) | | | | | | | |
| | Resistenza al gelo* - Frost resistance* Résistance au gel* - Frostbeständigkeit* - Морозоустойчивость* | ISO 10545-12 | Resistente - Resistant Résistante - Beständig - Стойкий | | | | | | | |
| | Resistenza all'attacco chimico • - Resistance to chemical attack • Résistance à l'attaque chimique • - Beständigkeit gegen Chemikalien • Устойчивость к химическому воздействию • | ISO 10545-13 | Resistente - Resistant Résistante - Beständig - Стойкий | | | | | | | |
| | Carico statico - Static load Charge statique - Statische Last Статическая нагрузка | EN 12825 | | 45x90 | 60x60 | 80x80 | 60x90 | 60x120 | 30x120 | |
| | | | | Centro - Centre - Au centre - Mitte - По центру | KN>5,0 | KN>5,0 | KN>5,0 | KN>5,0 | KN>5,0 | KN>3,0 |
| | | | | Centro lato - Side centre - Au centre latéralement | KN>4,0 | KN>7,0 | KN>7,0 | KN>8,0 | KN>4,0 | KN>3,0 |
| | | | | Mitte Seite - По центру грани | KN>4,0 | KN>5,0 | KN>5,0 | KN>6,0 | KN>4,0 | KN>3,0 |
| | | | | Diagonale - Diagonal - En diagonale | KN>7,0 | KN>8,0 | KN>8,0 | KN>8,0 | KN>7,0 | KN>6,5 |
| | | | | Diagonal - По диагонали | KN>7,0 | KN>8,0 | KN>8,0 | KN>8,0 | KN>7,0 | KN>6,5 |
| | Classe di carico di rottura*** - Breaking load class*** Classe de charge de rupture*** - Bruchlastklasse*** Класс стойкости к разрушающей нагрузке*** | EN 1339 | U11 T11 | | | | | | | |
| | Resistenza alle macchie* - Resistance to stains* Résistance aux taches* - Fleckenbeständigkeit* Устойчивость к образованию пятен* | ISO 10545-14 | Pulibile - Cleanable Nettoyable - Leicht zu reinigen Чистящийся | | | | | | | |
| | Resistenza allo scivolamento** - Slip resistance** Résistance au glissement** - Rutschhemmende Eigenschaft** Сопротивление скольжению** | DIN 51130 - DIN 51097 | R11 B BUILT | R11 C | ALCHEMY - ARTHIS - CLASH - COCOON - CORE - E-MOTIONS - EIKON - EXTRA C - FULL GRAUSTEIN - HIKE - IMAT - JOIN - KEY_MOOD - LIFE - MATERICA - MEET - ONE PORTRAITS - PRIMA - QUARTZ ESSENCE - ROXSTONES - SLAB - SHAPES OF ITALY TALE - VIBE | | | | | |
| | | ▲ ANSI A326.3 | Wet DCOF ≥ 0,55 | | | | | | | |
| | Spessore nominale - Nominal Thickness Épaisseur nominal - Nominalstärke Номинальная толщина | | 20 mm | | | | | | | |

* Valori medi riferiti agli ultimi due anni di produzione e relativi alla finitura naturale del prodotto - Average values referred to the last two years of production and related to the matt finish of the product - Valeurs moyennes des deux dernières années de production et relatifs à la finition naturelle du produit - Durchschnittswerte, die sich auf die letzten zwei Produktionsjahre beziehen und auf die matte Oberfläche - Средние значения относятся к последним двум годам производства и натуральной отделке поверхности

** Valori relativi alla finitura naturale del prodotto ed a test effettuati da laboratori esterni accreditati, disponibili in azienda; ci rendiamo disponibili alla verifica dell'eventuale lotto interessato all'acquisto. - As far as values relating to the matt finish of the product and to tests carried out by certified external laboratories whose results are available upon request at Headoffice, we are willing to check the lot you are interested in purchasing. - Valeurs se référant à la finition naturelle du produit selon des tests effectués par des laboratoires extérieurs accrédités et à la disposition de toute personne intéressée auprès de nos bureaux; nous sommes disponibles pour le contrôle de l'éventuel lot concerné par l'achat. - Werte bezogen auf das natürliche Produktfinish und in anerkannten externen Labors geprüft, im Unternehmen erhältlich; für eventuelle Prüfungen der zu erwerbenden Warenposten stehen wir gern zur Verfügung. - Значения, касающиеся натуральных характеристик изделий и тестов, выполненных внешними авторизованными лабораториями, имеются в компании. Мы готовы выполнить проверку партии товара, которую намереваетесь приобрести.

*** Dato riferito al formato 60x60 cm. - Detail referred to the 60x60 cm size. - Donnée se rapportant au format 60x60 cm. - Auf die Formate 60x60 cm bezogen. - Значения, касающиеся натуральных характеристик изделий и тестов.

• Per prodotti chimici di uso domestico e additivi per piscina. - For domestic chemicals and swimming pool additives. - Pour produits chimiques à usage domestique et additifs pour piscines. - Für chemische Produkte für den Hausgebrauch und Schwimmbadzusätze. - Для бытовых химикатов и добавок для бассейнов.

▲ Valori wet DCOF specifici disponibili in azienda - Wet DCOF specific values available at the company - Valeurs wet DCOF spécifiques disponibles à l'usine - Prüfwerte Wet DCOF stehen im Werk zur Verfügung - Показатели wet DCOF доступны при запросе

Le tonalità dei campioni sono da considerarsi puramente indicative. - Tones of samples are indicative. - Les tonalités des échantillons sont purement indicatives. Die farbtöne der Muster sind als rein indicativ zu betrachten. - Тона образцов ориентировочные.

Aextra30

Urban & outdoor solutions



I prodotti della gamma AEXTRA30 combinano prestazioni eccellenti in termini di resistenza e stabilità delle pavimentazioni con il valore estetico del design ceramico italiano. Per questo rappresentano la soluzione ideale per realizzare spazi pubblici e opere di arredo urbano come marciapiedi, piazzali e aree ciclabili.

Products of the AEXTRA30 range combine excellent technical performance in terms of resistance and stability with all the value of Italian ceramic design. For this reason, they are the ideal solution for public spaces such as sidewalks, courtyards, and bicycle lanes.

Les produits de la gamme AEXTRA30 allient d'excellentes performances en termes de résistance et de stabilité des sols à la valeur esthétique du design céramique italien. Ils sont donc la solution idéale pour réaliser des espaces publics et des aménagements urbains comme les trottoirs, les places et autres pistes cyclables.

Die Produkte der Linie AEXTRA30 vereinen hervorragende Leistungen in Sachen Beständigkeit und Stabilität des Bodenbelags mit dem ästhetischen Wert des Keramik-Designs aus Italien. Sie sind daher die ideale Lösung für öffentliche Bereiche und für die Stadtgestaltung wie Bürgersteige, Plätze und Radfahrwege.

Продукция из линейки AEXTRA30 объединяет в себе великолепные характеристики прочности и стабильности пола с эстетической ценностью дизайна итальянской керамики. Именно по этой причине она является идеальным решением для благоустройства общественных пространств и градостроительства, а именно для настила тротуаров, площадей и велодорожек.



Info
Resources
Tools



AEXTRA30

Floor: TALE CLASSICO CONTRO 60x60 AEXTRA30 TEXTURED RT R11 C

Formati - Soluzioni

Sizes - Solutions

Percorsi e distese . Pathways and dehor areas



Spazi pubblici . Public spaces

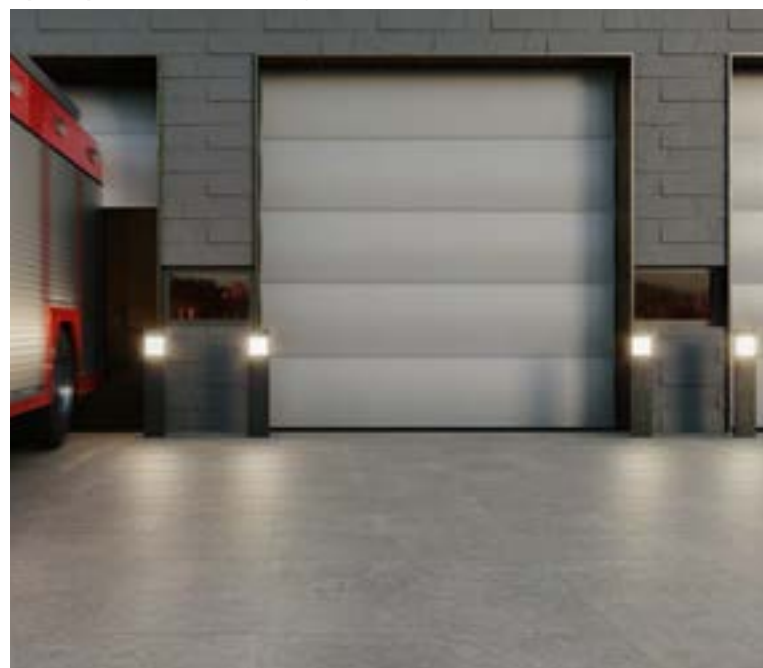

Zone ad alta affluenza . High density spaces

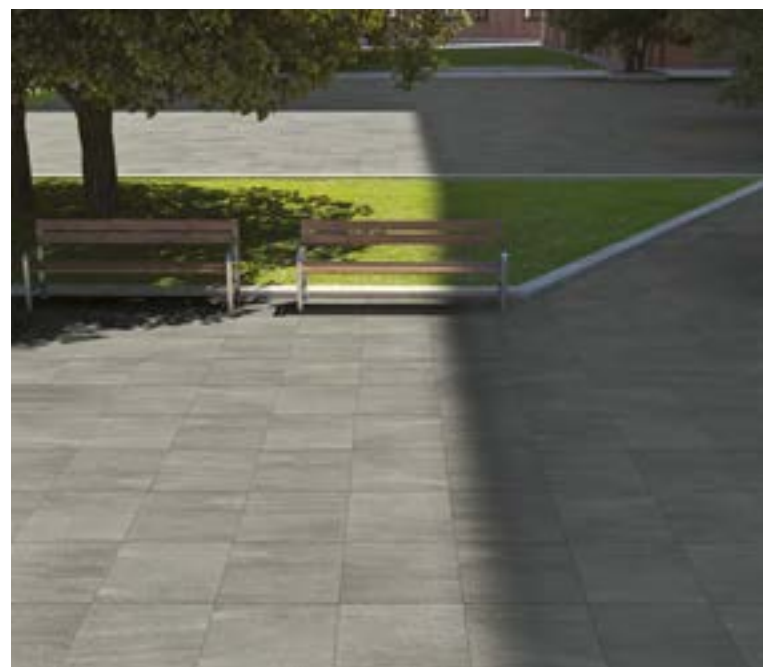

Zone carrabili . Carriageable areas



Posa su erba . Dry system installation



Posa sopraelevata . Raised installation



Posa su ghiaia . Installation onto gravel



Posa su sabbia . Installation onto sand



Posa tradizionale con colla . Traditional adhesive installation



Vantaggi

Advantages



Monolitico
Monolithic
Monolithique
Monolithisch



Ingelivo
Frostproof
Ingélif
Frostsicher



Ignifugo
Fireproof
Ignifuge
Feuerfest



Inassorbente
Non-absorbent
Non absorbant
Keine wasseraufnahme



Ecosostenibile
Eco-sustainable
Écodurable
Ökologisch nachhaltig



Resiste ai carichi
Load-resistant
Résiste aux charges
Belastbar

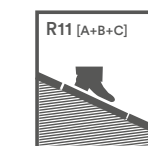

R11 [A+B+C]
Antiscivolo
Non-slip
Antidérapant
Rutschfest



Estremamente longevo
Extremely durable
Extrêmement durable
Extrem langlebig

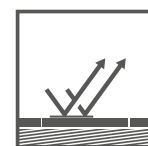

Resiste ai raggi UV
Uv ray resistant
Résiste aux uv
Uv-beständig

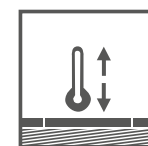

Resiste agli shock termici
Thermal shock resistant
Résiste aux chocs thermiques
Temperaturschockbeständig

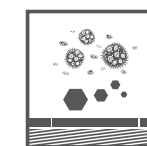

Resiste ai sali ai muschi e alle muffe
Resisting salt, moss and mould
Résiste aux sels, mousses et moisissures
Salz-, moos- und schimmelbeständig



Estremamente stabile nelle pose a secco
Extremely stable for dry installation
Extrêmement stable pour les poses à sec
Im trockenbau extrem stabil

30 mm



60x60
23⁵/₈"x23⁵/₈"

Aextra30

AEXTRA30

La gamma

The range

EXTRA C BASE MONS

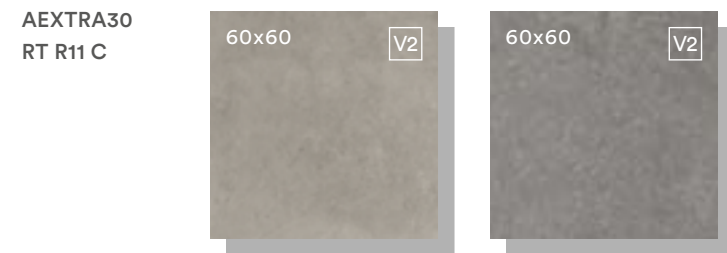

TALE CLASSICO CONTRO SILVER CONTRO

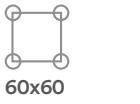

ISTRUZIONI PER LA POSA SOPRAELEVATA AEXTRA30 PER TUTTI I MERCATI, ESCLUSI USA, CANADA, OCEANIA - INSTRUCTIONS FOR AEXTRA30 RAISED INSTALLATION FOR ALL MARKETS, WITH THE EXCEPTION OF THE USA, CANADA, OCEANIA - INSTRUCTIONS POUR LA POSE SURÉLEVÉE - AEXTRA30 POUR TOUS LES MARCHÉS, SAUF USA, CANADA, OCÉANIE - VERLEGUNG ALS DOPPELBODEN AEXTRA30 FÜR ALLE MÄRKTE AUSSER USA, KANADA, OZEANIEN - УКЛАДКА АЕХТРА30 В КАЧЕСТВЕ ФАЛЬШПОЛА ДЛЯ ВСЕХ РЫНКОВ, КРОМЕ США, КАНАДЫ, ОКЕАНИИ

| Formato Size Format Format Формат | Altezza della sopraelevazione - Raise of the foot plan - Hauteur de la surélévation - Höhe des Doppelbodens - Высота монтажа | |
|-------------------------------------------------------------------------------------|---------------------------------------------------------------------------------------------------------------------------------------------------------------------------------------------------------|-----------------------------------------------------------------------------------------------------------------------------------------------------------------------------------------------------------------------------------------------------------------------------------------------------------------------------------------------------------------------------------------------------------------------------|
| | Fino a 10 cm Up to - Jusqu'à - Bis zu - До | Tra 10 e 30 cm From 10 to 30 cm Entre 10 et 30 cm 10 bis 30 cm От 10 до 30 см |
|  | 4 SUPPORTI/LASTRA (3,4 SUPPORTI/MQ) 4 supports/slab (3,4 supports/mq) 4 supports / dalle (3,4 supports / m ²) 4 Träger/Platte (3,4 Träger/qm) 4 опор/плитку (опоры/кв.м) | 4 SUPPORTI/LASTRA (3,4 SUPPORTI/MQ) + APPLICAZIONE DOPPIA RETE IN FIBRA DI VETRO 4 supports/slab (3,4 supports/mq) + application of a double glass fibre net 4 supports / dalle (3,4 supports / m ²) + application double treillis en fibre de verre 4 Träger/Platte (3,4 Träger/qm) + Aufkleben eines doppelten GFK-Netzes 4 опоры/плитку (3,4 опоры/кв.м) + двойная стекловолоконная сетка |

INSTRUCTIONS FOR RAISED FLOOR INSTALLATION – USA – CANADA – OCEANIA
INSTRUCTIONS POUR LA POSE SURÉLEVÉE – ETATS UNIS- CANADA - OCÉANIE

| Raise of the foot plan - Hauteur de la surélévation | | | | |
|-----------------------------------------------------|-------------------------------------------------------------------------------------|----------------------------------------------------------------------------------------------------------------------------------|----------------------------------------------------------|---------------------------------------------------------------|
| Size - Format | | Up to 3/4 inch - Jusqu'à 3/4 pouces (2cm) | Above 3/4 inch - Au-delà de 3/4 pouces (2cm) | |
| Size 23 5/8" x 23 5/8" (60x60cm) |  | 4 supports/slab (0,32 supports/sqft - 3,4 supports/mq) 4 supports /dalle (0,32 supports /sqft - 3,4 supports/m ²) | Please contact Ceramiche Caesar (Caesartech dept.) | Veillez consulter Ceramiche Caesar (Service Caesartech) |
| | | | | |

CARATTERISTICHE TECNICHE

TILE PERFORMANCE DATA - NOTES TECHNIQUES - TECHNISCHE AUSKÜNFTE - ТЕХНИЧЕСКАЯ ХАРАКТЕРИСТИКА

Classificazione secondo EN ISO 14411 ISO 13006 annesso G gruppo Bla con Ev ≤0,5% - Classification in accordance with EN ISO 14411 ISO 13006 annex G standards Bla with Ev ≤ 0,5% - Classification selon EN ISO 14411 ISO 13006 annexe G groupe Bla avec Ev ≤0,5% - Klassifizierung gemäß EN ISO 14411 ISO 13006 anlage G Gruppe Bla mit Ev ≤0,5% - Классификация в соответствии с EN ISO 14411 ISO 13006, приложение G, стандарт Bla, где Ev ≤0,5%

| IMBALLI - PACKAGING - CONDITIONNEMENT - VERPACKUNGS-EINHEITEN - УПАКОВКА | | | | | | | |
|--------------------------------------------------------------------------|-----------------------------------------|------------------------------------------|------|--------|----------------------------|-------|---------|
| Formato - Size - Format - Формат | | Scatola - Box - Boîte - Karton - Коробка | | | Pallet - Palette - Паллета | | |
| CM | INCHES | PZ | MQ | KG | SC | MQ | KG |
| 60x60 | 23 ^{5/8} "x23 ^{5/8} " | 1 | 0,36 | ~23,68 | 40 | 14,40 | ~947,20 |

I prodotti Aextra30, in virtù di particolari processi produttivi, possono mostrare variazioni di tono anche significative rispetto al corrispondente prodotto in spessore tradizionale. - Aextra30 products, due to their special manufacturing processes, can feature considerable shade variations compared to similar products in standard thickness. - Les produits Aextra30, en vertu de processus de production particuliers, peuvent présenter des variations de couleur, même significatives, par rapport au produit correspondant dans l'épaisseur traditionnelle. - Die Aextra30 Produkte können aufgrund ihres speziellen Herstellungsverfahrens gegenüber dem entsprechenden Produkt in traditioneller Stärke Unterschiede, auch erhebliche, im Farbton aufweisen. - Изделия Aextra30 в силу технологических особенностей изготовления могут значительно отличаться по тону от соответствующих изделий традиционной толщины.

RT Rettificato, quadrato, monocalibro. - Rectified, squared, one caliber. - Rectifié, mis d'équerre et monocalibre. - Rektifiziert, rechteckig und Ein kaliber. - Ректифицированный, одного калибра.















* Valori medi riferiti agli ultimi due anni di produzione e relativi alla finitura naturale del prodotto - Average values referred to the last two years of production and related to the matt finish of the product - Valeurs moyennes des deux dernières années de production et relatifs à la finition naturelle du produit - Durchschnittswerte, die sich auf die letzten zwei Produktionsjahre beziehen und auf die matte Oberfläche - Средние значения относятся к последним двум годам производства и натуральной отделке поверхности

** Valori relativi alla finitura naturale del prodotto ed a test effettuati da laboratori esterni accreditati, disponibili in azienda; ci rendiamo disponibili alla verifica dell'eventuale lotto interessato all'acquisto. - As far as values relating to the matt finish of the product and to tests carried out by certified external laboratories whose results are available upon request at Headoffice, we are willing to check the lot you are interested in purchasing. - Valeurs se référant à la finition naturelle du produit selon des tests effectués par des laboratoires extérieurs accrédités et à la disposition de toute personne intéressée auprès de nos bureaux; nous sommes disponibles pour le contrôle de l'éventuel lot concerné par l'achat. - Werte bezogen auf das natürliche Produktfinish und in anerkannten externen Labors geprüft, im Unternehmen erhältlich; für eventuelle Prüfungen der zu erwerbenden Warenposten stehen wir gern zur Verfügung. - Значения, касающиеся натуральных характеристик изделий и тестов, выполненных внешними авторизованными лабораториями, имеются в компании. Мы готовы выполнить проверку партии товара, которую намереваетесь приобрести.

• Per prodotti chimici di uso domestico e additivi per piscina. - For domestic chemicals and swimming pool additives. - Pour produits chimiques à usage domestique et additifs pour piscines. - Für chemische Produkte für den Hausgebrauch und Schwimmbadzusätze. - Для бытовых химикатов и добавок для бассейнов.

▲ Valori wet DCOF specifici disponibili in azienda - Wet DCOF specific values available at the company - Valeurs wet DCOF spécifiques disponibles à l'usine - Prüfwerte Wet DCOF stehen im Werk zur Verfügung - Показатели wet DCOF доступны при заказе

Le tonalità dei campioni sono da considerarsi puramente indicative. - Tones of samples are indicative. - Les tonalités des échantillons sont purement indicatives. - Die Farbtöne der Muster sind als rein indicativ zu betrachten. - Тона образцов ориентировочные.

| | CARATTERISTICA TECNICA TECHNICAL CHARACTERISTIC CARACTERISTIQUE TECHNIQUE TECHNISCHE DATEN ТЕХНИЧЕСКАЯ ХАРАКТЕРИСТИКА | METODO DI PROVA TESTS METHOD METHODE D'ESSAI TESTMETHODE МЕТОД ИСПЫТАНИЯ | VALORE * MEDIO "CAESAR" AVERAGE "CAESAR" VALUE * VALEUR * MOYEN "CAESAR" "CAESAR" DURCHSCHNITTSWERT * СРЕДНЕЕ ЗНАЧЕНИЕ "CAESAR" * | AEXTRA ₃₀ |
|---------------------------------------------------------------------------------------|--------------------------------------------------------------------------------------------------------------------------------------------------------------------------------------------------------------------------------------------|--------------------------------------------------------------------------------------|------------------------------------------------------------------------------------------------------------------------------------------------------------------------------------------------------------------------------------------------------------------------------------------------|----------------------------------------------|
|  | Dimensione - Size Dimension - Abmessungen - Размер | ISO 10545-2 | Conforme - In accordance Conforme - Erfüllt - Соответствует | |
|  | Assorbimento d'acqua* - Water absorption* Absorption d'eau* - Wasseraufnahme* - % Поглощения воды* | ISO 10545-3 | ≤ 0,1% | |
|  | Resistenza alla flessione* - Bending strength* Résistance à la flexion* - Biegezugfestigkeit* - Упругость* | ISO 10545-4 | Non applicabile a piastrelle con una forza di rottura Not applicable to tiles with a breaking strength N'est pas applicable aux carreaux avec une charge de rupture Nicht anwendbar bei Fliesen mit einer Bruchlast Не применяется в отношении плиток с прочностью на изрыв | ≥ 3000 N ≥ 3000 N ≥ 3000 N ≥ 3000 N |
|  | Sforzo di rottura (S) - Breaking strength Charge de rupture - Bruchlast - Разрушающее усилие | ISO 10545-4 | > 21.000 N | |
|  | Resistenza all'abrasione profonda* - Deep scratch resistance* Résistance à l'abrasion profonde* - Widerstand gegen Tiefenverschleiß* Устойчивость глубокому истиранию* | ISO 10545-6 | Conforme - In accordance Conforme - Erfüllt - Соответствует | |
|  | Coefficiente di dilatazione termica lineare* - Thermal linear expansion coefficient* Coefficient de dilatation thermique linéaire* - Koeffizient der linearen thermischen Dehnung* - Коэффициент линейного теплового расширения* | ISO 10545-8 | = 7 (10 ⁻⁶ °C ⁻¹) | |
|  | Resistenza agli sbalzi termici* - Thermal shock resistance* Résistance aux écarts de température* - Temperaturwechsel Beständigkeit* Устойчивость к тепловому перепаду* | ISO 10545-9 | Resistente - Resistant Résistante - Beständig - Стойкий | |
|  | Dilatazione all'umidità* - Expansion in humidity* Dilatation à l'humidité* - Feuchtigkeitsausdehnung* Расширение в условиях влажности* | ISO 10545-10 | ≤ 0,1 (mm/m) | |
|  | Resistenza al gelo* - Frost resistance* Résistance au gel* - Frostbeständigkeit* - Морозостойчивость* | ISO 10545-12 | Resistente - Resistant Résistante - Beständig - Стойкий | |
|  | Resistenza all'attacco chimico • - Resistance to chemical attack • Résistance à l'attaque chimique • - Beständigkeit gegen Chemikalien • Устойчивость к химическому воздействию • | ISO 10545-13 | Resistente - Resistant Résistante - Beständig - Стойкий | |
|  | Carico statico - Static load Charge statique - Statische Last Статическая нагрузка | EN 12825 | Centro - Centre - Au centre - Mitte - По центру Centro lato - Side centre - Au centre latéralement Mitte Seite - По центру грани Diagonale - Diagonal - En diagonale Diagonal - По диагонали | 60x60 KN>7,0 KN>5,0 KN>8,0 |
|  | Classe di carico di rottura - Breaking load class Classe de charge de rupture - Bruchlastklasse Класс стойкости к разрушающей нагрузке | EN 1339 | U25 T25 | |
|  | Resistenza alle macchie* - Resistance to stains* Résistance aux taches* - Fleckenbeständigkeit * Устойчивость к образованию пятен* | ISO 10545-14 | Pulibile - Cleanable Nettoyable - Leicht zu reinigen Чистящийся | |
|  | Resistenza allo scivolamento** - Slip resistance** Résistance au glissement** - Rutschhemmende Eigenschaft** Сопротивление скольжению** | DIN 51130 - DIN 51097 ▲ ANSI A326.3 | R11 C Wet DCOF ≥ 0,55 | |
|  | Spessore nominale - Nominal Thickness Épaisseur nominale - Nominalstärke Номинальная толщина | | 30 mm | |

Project Evolution

PROJECT EVOLUTION

Extended beauty



Le grandi lastre in grès porcellanato elevano a nuovi traguardi la bellezza della materia, e rendono speciali gli ambienti dove sono posate.

Large format tile elevates the beauty of porcelain to the next level, making every space special.

Les grandes dalles en grès cérame hissent à de nouveaux sommets la beauté de la matière, et personnalisent les lieux où elles sont posées.

Die großen Feinsteinzeugplatten erheben die Schönheit der Materie auf ein ganz neues Niveau und machen die Räume, in denen sie verlegt sind, zu etwas wirklich Besonderem.

Большие керамогранитные плиты поднимают красоту материала на новые высоты, придавая интерьерам изысканную эксклюзивность.



Info
Resources
Tools



Floor: ANIMA FUTURA GOLDEN WHITE 60x120 MATT RT, Meet CHIC BEIGE 20x120 MATT RT
Wall: ANIMA FUTURA CRYSTAL DELIGHT 120x278 LUCIDATO RT, ANIMA FUTURA GOLDEN WHITE 120x278 LUCIDATO RT
Furniture by OLOS: ANIMA FUTURA AMAZING SILVER 120x278 LUCIDATO RT, ANIMA FUTURA GOLDEN WHITE COMPOSIZIONE N BRASS 30x30 LUCIDATO RT

Project Evolution

Formati

Sizes

160x320 . 120x278 6 mm LUCIDATO RT

160x320 . 120x278 6 mm SILK RT

160x320 . 120x278 6 mm MATT RT

120x278 6 mm MATT RT



6 mm



160x320
63"x126"

LUCIDATO RT
SILK RT
MATT RT

6 mm

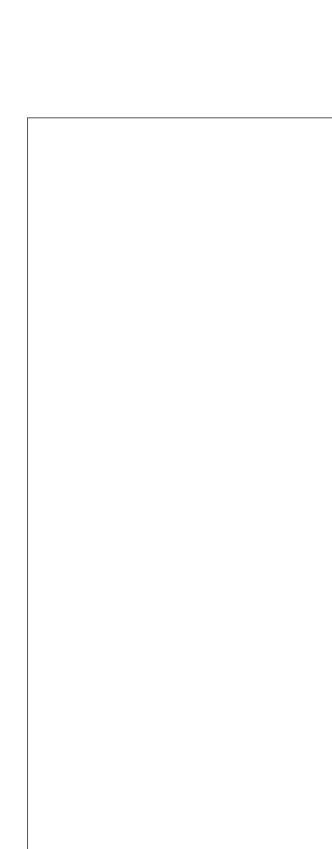

120x278
47²/₈"x109⁷/₁₆"

LUCIDATO RT
SILK RT
MATT RT

Project Evolution

La gamma Metal Look

The Metal Look range

ALCHEMY



La gamma Concrete Look

The Concrete Look range

JOIN

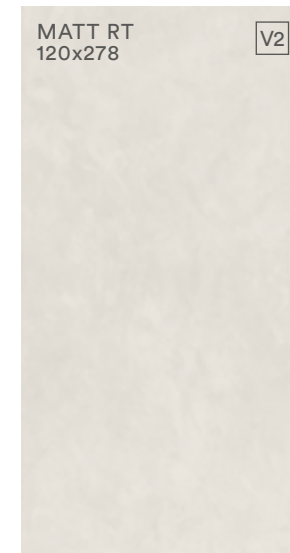

RELATE FLAME

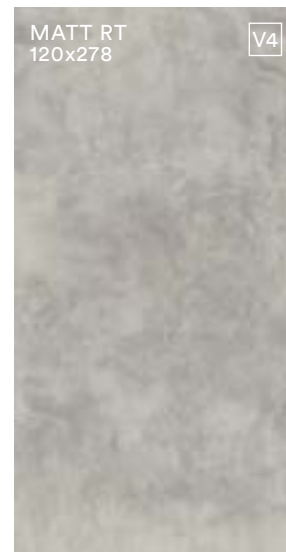

PRIMA



RT Rettificato, squadrato, monocalibro. - Rectified, squared, one caliber. - Rectifié, mis d'équerre et monocalibre. - Rektifiziert, rechtwinkelig und Ein kaliber. - Ректифицированный, одного калибра.

Project Evolution

La gamma Marble Look

The Marble Look range

ANIMA



Statuario Venato

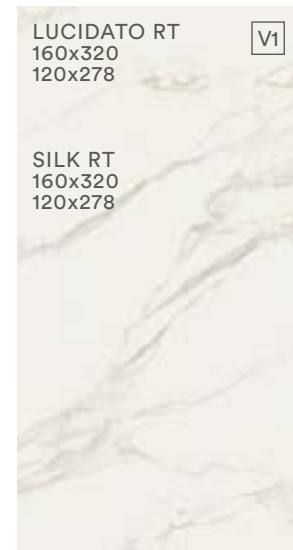

Calacatta Oro



Graphite

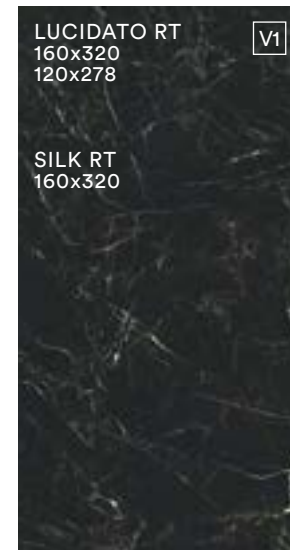

Nero Atlante

ANIMA FUTURA



Golden White



Majestic White



Amazing Silver



Unique Black



Keen Grey

ANIMA EVER



Magnificent White

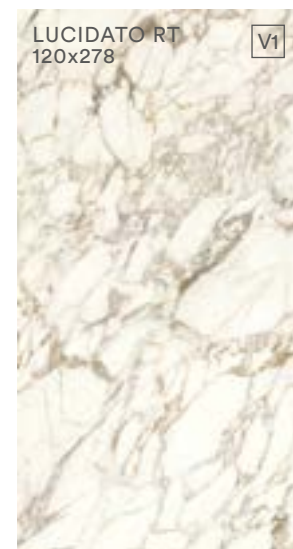

Luxury Arabesque

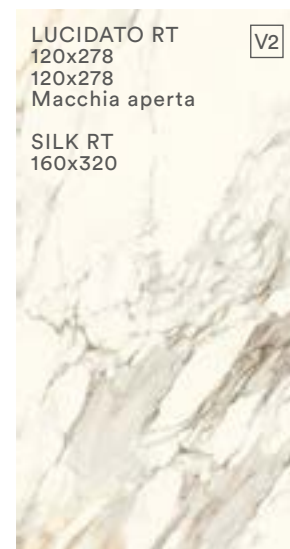

Apuan Gold



Sage Green

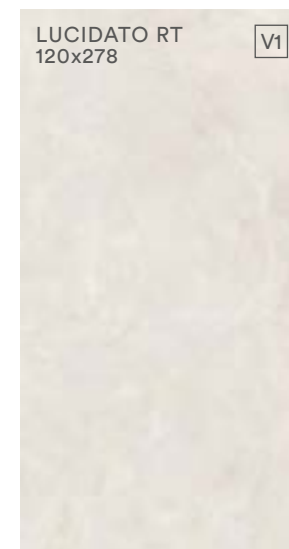

Royal Onyx



Crystal Delight

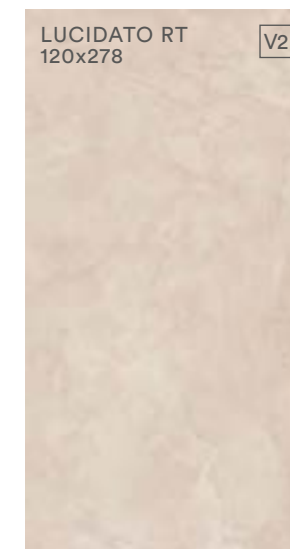

Pink Onyx

Project Evolution

La gamma Stone Look

The Stone Look range

PORTRAITS



Comblanchien



Faro



Kirkby

SHAPES OF ITALY



Iulia

* Lastra disponibile anche in spessore 12 mm, formato 162x324, non rettificata e non squadrata. - Slab also available with a thickness of 12 mm, size 162x324, non-rectified and non-wedged. - Dalle disponible également en 12 mm d'épaisseur, format 162x324, non rectifiée et non équaree. / Die Platte ist auch im Format 162x324 mit 12 mm Stärke, nicht rektifiziert und nicht abgekantet, erhältlich. - Плита предлагается также с толщиной 12 мм, в формате 162x324, нешлифованная и необрезная.

La gamma Classic

The Classic range

TINTE UNITE

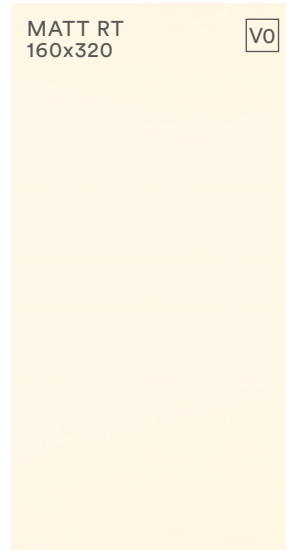

Purewhite

RT Rettificato, quadrato, monocalibro. - Rectified, squared, one caliber. - Rectifié, mis d'équerre et monocalibre. - Rektifiziert, rechtwinkelig und Ein kaliber. - Ректифицированный, одного калибра.

La gamma Join 120x278

The Join 120x278 range

DECO 120x278 cm . 47²/₈"x109⁷/₁₆" MATT RT *



SPICE

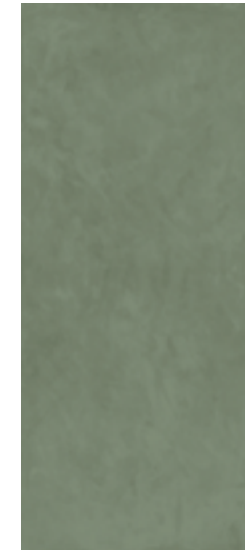

VERVE

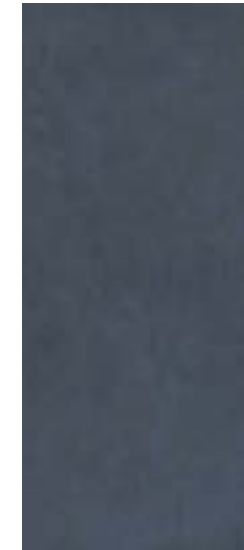

INK

REED 120x278 cm . 47²/₈"x109⁷/₁₆" MATT RT *



DUSK 120x278 cm . 47²/₈"x109⁷/₁₆" MATT RT *

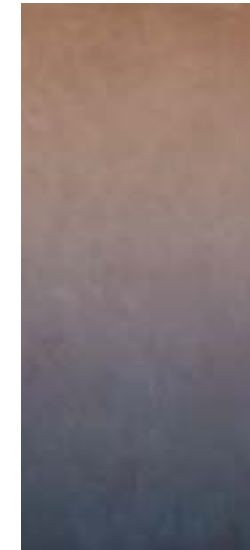

SPICE



VERVE

HOOP 120x278 cm . 47²/₈"x109⁷/₁₆" MATT RT *



A



B

* Solo per rivestimento.
Only for wall application.
Exclusivement pour revêtement mural.
Nur als Wandverkleidung geeignet.
Только для облицовки.

I decori di Join in formato 120x278 sono realizzati tramite particolari applicazioni sulla superficie, successive alla cottura. Per la pulizia ordinaria, Caesar sconsiglia l'utilizzo di prodotti abrasivi, che potrebbero danneggiare la superficie; per evitare opacizzazioni o graffiature, si consiglia di eseguire la pulizia con un panno morbido e detersivi a PH neutro. In fase di posa del materiale, Caesar sconsiglia l'utilizzo di sistemi meccanici livellanti, che potrebbero causare danni alla superficie quando vengono rimossi. Prima di stuccare, si consiglia di proteggere la superficie nelle parti vicino al bordo con nastro adesivo per mascheratura; si raccomanda di utilizzare stucchi a base cementizia e non epossidica. Subito dopo la stuccatura, rimuovere gli eventuali residui con acqua e un panno morbido, senza l'utilizzo di spugne abrasive.

The 120x278 cm decors of the Join collection were created using special surface applications after baking. For ordinary cleaning, Caesar advises to avoid abrasive products that could damage the surface. Cleaning with a soft cloth and neutral PH products is recommended to avoid dulling or scratching. When laying the material, Caesar recommends not to use mechanical levelling systems, which could cause damage to the surface when removed. Before grouting, it is advised to protect the surface in the parts near the edge with masking tape. Cement-based, not epoxy-based, grouts must be used. Immediately after grouting, remove any residues with water and a soft cloth, without using abrasive sponges.

Les décors de Join en format 120x278 ont été réalisées grâce à des applications spéciales sur la surface, successives à la cuisson. Pour l'entretien ordinaire, Caesar déconseille d'utiliser des produits abrasifs, qui pourraient endommager la surface. Afin d'éviter opacification et rayures, il est conseillé d'effectuer le nettoyage à l'aide d'un chiffon souple et de produits au pH neutre. Lors de la pose du matériau, Caesar déconseille d'utiliser des systèmes mécaniques de nivellement, qui pourraient causer des dommages sur la surface lorsqu'on les retire. Avant le jointoiment, il est conseillé de protéger la surface aux endroits proches du bord à l'aide de ruban adhésif de masquage, et il est recommandé d'utiliser un mortier à base de ciment et non époxy. Tout de suite après le jointoiment, retirer les éventuels restes avec de l'eau et un chiffon souple, sans utiliser d'éponge abrasive.

Die Dekore im Format 120x278 cm aus der Serie Join entstehen mit besonderen Applikationen nach dem Brennvorgang. Für die normale Reinigung rät Caesar von Scheuermitteln ab, da diese die Oberfläche beschädigen könnten. Um matte Stellen und Kratzer zu vermeiden, sollten zur Reinigung nur weiche Tücher und Produkte mit neutralem pH-Wert verwendet werden. Bei der Verlegung des Materials rät Caesar von mechanischen Nivelliermitteln ab, da die Oberfläche bei ihrer Entfernung Schaden nehmen könnte. Vor dem Verfugen sollte die Oberfläche an den Kanten abgeklebt werden; wir empfehlen zementhaltige Fugenmörtel und keine Epoxidharz-Fugenmassen. Eventuelle Rückstände sind sofort nach dem Verfugen mit einem trockenen Tuch und Wasser zu entfernen. Keine Scheuerschwämme verwenden.

Декоры коллекции Join в формате 120x278 реализованы, после обжига, методом специального поверхностного нанесения. Компания Caesar рекомендует не использовать абразивные чистящие средства во избежание повреждения поверхности. Для предотвращения помутнения или появления царапин рекомендуется проводить очистку чистой ветошью и нейтральными моющими средствами. При укладке плитки компания Caesar не рекомендует использовать механические выравнивающие приспособления, способные повредить поверхность. Перед затиркой швов рекомендуется защитить края плитки малярным скотчем. Рекомендуется использовать затирочные составы на цементной, а не эпоксидной основе. После затирки швов необходимо удалить остатки материала мягкой ветошью и водой, не применяя абразивные губки.

Project Evolution

La gamma DECO_ 120x278

The DECO_ 120x278 range

IMPRESSION 120x278 cm . 47²/₈"x109⁷/₁₆" MATT RT

Range faces



Realizzato su **Prima** - Ecrú.
Made on **Prima** - Ecrú.
Fabriqué sur **Prima** - Ecrú.
Realisiert bei **Prima** - Ecrú.
Реализовано на основе **Prima** - Ecrú.

RAMMED 120x278 cm . 47²/₈"x109⁷/₁₆" MATT RT

Range faces



*** JUNGLE** 120x278 cm . 47²/₈"x109⁷/₁₆" MATT RT

Range faces



A B

*** SPRING** 120x278 cm . 47²/₈"x109⁷/₁₆" MATT RT

Range faces

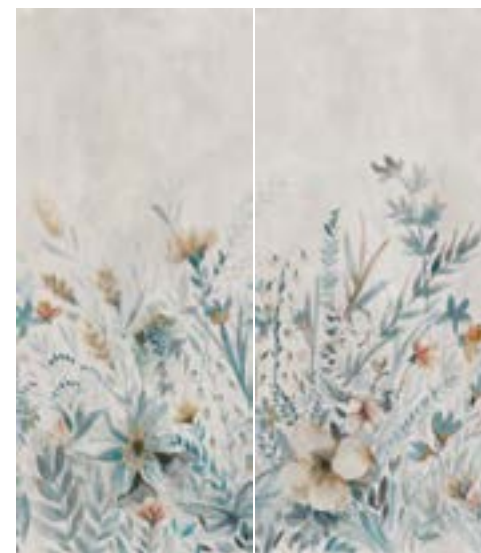

A B

*** PAMPA** 120x278 cm . 47²/₈"x109⁷/₁₆" MATT RT

Range faces



A B C

*** WATERCOLOR** 120x278 cm . 47²/₈"x109⁷/₁₆" MATT RT

Range faces



A B C

Le lastre potrebbero presentare minimi disallineamenti tra le grafiche in continuità: ciò è da intendersi come caratteristica intrinseca del prodotto.

There may be minor misalignments of continuous graphics: this is to be considered as an intrinsic feature of the product.

Die Platten könnten untereinander minimale Abweichungen in der Ausrichtung des graphischen Designs aufweisen: dies ist als ein charakteristisches Merkmal des Produktes zu betrachten.

Les dalles peuvent présenter de faibles écarts de graphiques en continuité: ceci est une caractéristique intrinsèque du produit.

У плит может наблюдаться минимальная нестыковка сплошного рисунка, которая должна считаться особенностью изделия.

* I decori con più grafiche sono inscatolati in maniera casuale; in caso di scelta di una o più facce specifiche rivolgersi agli uffici commerciali.

Decorations with several graphic patterns are boxed randomly; if you choose one or more specific sides of the product, please contact our sales department.

Dekore mit mehreren grafischen Varianten. Diese werden nach dem Zufallsprinzip verpackt. Sollten eine oder mehrere spezifische Varianten gewünscht werden, dann wende man sich bitte an unsere Vertriebsabteilung.

Les décors avec plusieurs motifs sont emballés de manière aléatoire; en cas de choix d'une ou plusieurs faces spécifiques, s'adresser aux bureaux commerciaux.

Декоры с множеством лиц упакованы в коробки в произвольном порядке. В случае выбора определенных лиц, пожалуйста, обращайтесь в офис продаж.

Project Evolution

La gamma Gold_120x278

The Gold_120x278 range

GOLD MAGNOLIA 120x278 cm . 47²/₈"x109⁷/₁₆" LUCIDATO RT



Realizzato su **Anima Futura** - Unique Black lucidato.
Made on **Anima Futura** - Unique Black polished.
Fabriqué sur **Anima Futura** - Unique Black poli.
Realisiert bei **Anima Futura** - Unique Black glänzend.
Реализовано на основе **Anima Futura** - Unique Black с полированной отделкой.

GOLD WILLOW 120x278 cm . 47²/₈"x109⁷/₁₆" MATT RT

Range faces



A

B

Realizzato su **Prima** - Concrete.
Made on **Prima** - Concrete.
Fabriqué sur **Prima** - Concrete.
Realisiert bei **Prima** - Concrete.
Реализовано на основе **Prima** - Concrete.

Solo per rivestimento. - Only for wall application. - Exclusivement pour revêtement mural. - Nur als Wandverkleidung geeignet. - Только для облицовки.

RT Rettificato, squadrato, monocalibro. - Rectified, squared, one caliber. - Rectifié, mis d'équerre et monocalibre. - Rektifiziert, rechteckig und Ein kaliber. - Ректифицированный, одного калибра.

I decori 120x278 Gold sono realizzati tramite applicazione da terzo fuoco di inchiostri a base oro. - The 120x278 Gold decorations are produced by third-firing application of gold-based inks. - Les décors 120x278 Gold sont réalisés par application au troisième feu d'encre à base d'or. - Die Dekore 120x278 Gold werden durch Auftragen von Golddruckfarben im Drittbrand hergestellt. - Декоры 120x278 Gold производятся методом третьего обжига с применением красок на золотой базе.

I decori di **Gold Magnolia** e **Gold Willow** in formato 120x278 sono realizzati tramite particolari applicazioni sulla superficie, successive alla cottura.

Per la pulizia ordinaria, Caesar sconsiglia l'utilizzo di prodotti abrasivi, che potrebbero danneggiare la superficie; per evitare opacizzazioni o graffiature, si consiglia di eseguire la pulizia con un panno morbido e detergenti a PH neutro.

In fase di posa del materiale, Caesar sconsiglia l'utilizzo di sistemi meccanici livellanti, che potrebbero causare danni alla superficie quando vengono rimossi. Prima di stuccare, si consiglia di proteggere la superficie nelle parti vicino al bordo con nastro adesivo per mascheratura; si raccomanda di utilizzare stucchi a base cementizia e non epossidica. Subito dopo la stuccatura, rimuovere gli eventuali residui con acqua e un panno morbido, senza l'utilizzo di spugne abrasive.

The 120x278 cm decors of the **Gold Magnolia** and **Gold Willow** collections were created using special surface applications after baking.

For ordinary cleaning, Caesar advises to avoid abrasive products that could damage the surface. Cleaning with a soft cloth and neutral PH products is recommended to avoid dulling or scratching. When laying the material, Caesar recommends not to use mechanical levelling systems, which could cause damage to the surface when removed. Before grouting, it is advised to protect the surface in the parts near the edge with masking tape. Cement-based, not epoxy-based, grouts must be used. Immediately after grouting, remove any residues with water and a soft cloth, without using abrasive sponges.

Les décors de **Gold Magnolia** et **Gold Willow** 120x278 ont été réalisés grâce à des applications spéciales sur la surface, successives à la cuisson.

Pour l'entretien ordinaire, Caesar déconseille d'utiliser des produits abrasifs, qui pourraient endommager la surface. Afin d'éviter opacification et rayures, il est conseillé d'effectuer le nettoyage à l'aide d'un chiffon souple et de produits au pH neutre. Lors de la pose du matériau, Caesar déconseille d'utiliser des systèmes mécaniques de nivellement, qui pourraient causer des dommages sur la surface lorsqu'on les retire. Avant le jointoiement, il est conseillé de protéger la surface aux endroits proches du bord à l'aide de ruban adhésif de masquage, et il est recommandé d'utiliser un mortier à base de ciment et non époxy. Tout de suite après le jointoiement, retirer les éventuels restes avec de l'eau et un chiffon souple, sans utiliser d'éponge abrasive.

Die Dekore im Format 120x278 cm aus der Serie **Gold Magnolia** und **Gold Willow** entstehen mit besonderen Applikationen nach dem Brennvorgang.

Für die normale Reinigung rät Caesar von Scheuermitteln ab, da diese die Oberfläche beschädigen könnten. Um matte Stellen und Kratzer zu vermeiden, sollten zur Reinigung nur weiche Tücher und Produkte mit neutralem pH-Wert verwendet werden. Bei der Verlegung des Materials rät Caesar von mechanischen Nivelliermitteln ab, da die Oberfläche bei ihrer Entfernung Schaden nehmen könnte. Vor dem Verfugen sollte die Oberfläche an den Kanten abgeklebt werden; wir empfehlen zementhaltige Fugenmörtel und keine Epoxidharz-Fugenmassen. Eventuelle Rückstände sind sofort nach dem Verfugen mit einem trockenen Tuch und Wasser zu entfernen. Keine Scheuerschwämme verwenden.

Декоры коллекции **Gold Magnolia** e **Gold Willow** в формате 120x278 реализованы, после обжига, методом специального поверхностного нанесения.

Компания Caesar рекомендует не использовать абразивные чистящие средства во избежание повреждения поверхности. Для предотвращения помутнения или появления царапин рекомендуется проводить очистку чистой ветошью и нейтральными моющими средствами. При укладке плитки компания Caesar не рекомендует использовать механические выравнивающие приспособления, способные повредить поверхность. Перед затиркой швов рекомендуется защитить края плитки малярным скотчем. Рекомендуется использовать затирочные составы на цементной, а не эпоксидной основе. После затирки швов необходимо удалить остатки материала мягкой ветошью и водой, не применяя абразивные губки.

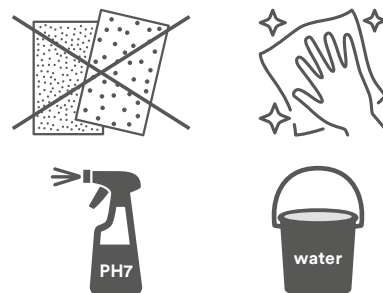

Floor: **PRIMA LEAD** 60x120 MATT RT R10 B
Wall: **GOLD WILLOW** 120x278 MATT GL RT, **PRIMA CONCRETE** 120x278 MATT RT
Furniture by CLOS: **PRIMA CONCRETE** 120x278 MATT RT

Vein Match

Su sei colori della gamma Anima Futura sono disponibili i set Vein Match, singoli articoli composti da 4 o 5 lastre in formato 120x278 cm. Questa proposta garantisce un effetto sequenziale a vena continua dall'effetto estetico altamente suggestivo.

Vein Match sets are available on six colours in the Anima Futura range, individual items consisting of 4 or 5 slabs in 120x278 cm size. This proposal guarantees a sequential continuous vein effect with a highly suggestive aesthetic effect.

Les ensembles Vein Match, des articles simples composés de 4 ou 5 dalles au format 120x278 cm, sont disponibles sur six couleurs de la gamme Anima Futura. Cette proposition garantit un effet séquentiel à veine continue avec un cachet esthétique très suggestif.

Für sechs Farben der Serie Anima Futura sind die aus jeweils 4 oder 5 Platten im Format 120x278 cm bestehenden Vein Match-Sets erhältlich. Diese garantieren mit ihrer durchgehenden Äderung einen höchst ansprechenden, sequenziellen Effekt.

В шести цветах гаммы Anima Futura доступны наборы Vein Match, где отдельные изделия состоят из 4 или 5 плит формата 120x278 см. Это предложение гарантирует эффект последовательных непрерывных прожилок с впечатляющим эстетическим эффектом.



ANIMA FUTURA
Golden White
Majestic White
Amazing Silver
Unique Black
Keen Grey
Crystal Delight

Vein Match è un set venduto in cassa e composto da tutte le lastre che caratterizzano il design del prodotto (4 o 5 come specificato caso per caso), con continuità di venatura. Le lastre potrebbero presentare minimi disallineamenti tra loro: ciò è da intendersi come caratteristica intrinseca del prodotto. Maggiori informazioni a pag. 144 - 145.

Vein Match is a set sold in a box and consists of all the slabs that characterise the product design (4 or 5 as specified in each case), with veining continuity. Slabs may have slight misalignments between them: this is to be understood as an intrinsic characteristic of the product. More information at page 144 - 145.

Vein Match est un ensemble vendu en caisses et composé de toutes les dalles qui caractérisent le design du produit (4 ou 5 tel que spécifié au cas par cas), avec une continuité de veines. Les dalles pourraient présenter de très légers décalages : cela doit être considéré comme une caractéristique intrinsèque du produit. Pour plus d'informations, voir aux pages 144 - 145.

Vein Match ist ein in Kisten verkaufte Set mit allen das Design des Artikels bildenden Platten (4 oder 5, wie jeweils angegeben), die durchgehend geädert sind. Minimale Fluchtungsabweichungen sind möglich: dies ist ein typisches Merkmal des Produkts. Weitere Informationen auf Seite 144 - 145.

Vein Match - это набор, продающийся в коробке и состоящий из всех тех плит, которые характерны для дизайна продукта (4 или 5, как указано в каждом конкретном случае), с непрерывностью рисунка вен. Плиты могут иметь небольшую несочетаемость между собой, которая должна расцениваться как неотъемлемая характеристика продукта. Дополнительная информация на страницах 144 - 145.

Macchia aperta

Bookmatch

ANIMA EVER APUAN GOLD 120x278 cm . 47²/₈"x109⁷/₁₆" LUCIDATO RT

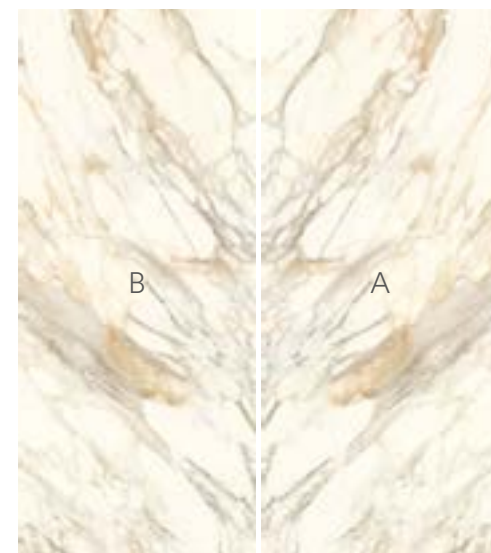

Le lastre potrebbero presentare minimi disallineamenti tra le venature in continuità: ciò è da intendersi come caratteristica intrinseca del prodotto.

There may be minor misalignments of continuous veins: this is to be considered as an intrinsic feature of the product.

Les dalles peuvent présenter de faibles écarts de continuité des veines : ceci est une caractéristique intrinsèque du produit.

Die Platten können unter den durchgehenden Äderungen minimale Fluchtungsabweichungen aufweisen: dies ist ein charakteristisches Merkmal des Produkts.

У плит может наблюдаться минимальная нестыковка сплошного рисунка, которая должна считаться особенностью изделия.

Continuità di vena

Continuous veins

Continuità di venatura.
Nei colori elencati di seguito, le lastre possono essere utilizzate per creare i suggestivi effetti di continuità di vena tipici di alcune tipologie di marmi pregiati.

Continuous veins.
Slabs can be used to create beguiling continuous vein effects that are typically achieved using certain prized marble varieties, in the colours listed below.

Veines continues.
Dans les couleurs indiquées ci-dessous, les dalles peuvent être utilisées pour créer les effets suggestifs de continuité de veine typiques de certains marbres précieux.

Durchgehende Äderungen.
In den nachstehenden Farben lassen sich mit den Platten die faszinierenden Effekte durchlaufender Äderungen erzielen, wie sie für einige kostbare Marmorarten typisch sind.

Непрерывность рисунка
Плиты в цветах, перечисленных ниже, могут использоваться для создания красивых эффектов непрерывности рисунка вен, которые характерны для некоторых ценных пород мрамора.

160x320 cm . 63"x126" SILK RT



ANIMA
Statuario Venato
Calacatta Oro

ANIMA EVER
Apuan Gold

120x278 cm . 47²/₈"x109⁷/₁₆" LUCIDATO RT



ANIMA
Statuario Venato
Calacatta Oro

ANIMA EVER
Magnificent White
Apuan Gold
Luxury Arabesque

Essendo l'inserimento delle lastre nelle confezioni casuale, Caesar non garantisce a priori le tipologie di facce presenti all'interno di ogni singola confezione. Le lastre potrebbero presentare minimi disallineamenti tra le venature in continuità: ciò è da intendersi come caratteristica intrinseca del prodotto.

Since slabs are packaged in a random manner, Caesar cannot guarantee the type of faces inside each package. There may be minor misalignments of continuous veins: this is to be considered as an intrinsic feature of the product.

L'introduction des dalles dans les emballages étant casuelle, Caesar ne garantit pas a priori les typologies de faces présentes dans chaque emballage. Les dalles peuvent présenter de faibles écarts de continuité des veines : ceci est une caractéristique intrinsèque du produit.

Da die Platten nach dem Zufallsprinzip verpackt werden, kann Caesar die in jeder einzelnen Verpackung enthaltenen Varianten der Oberflächengrafik nicht garantieren. Die Platten können unter den durchgehenden Äderungen minimale Fluchtungsabweichungen aufweisen: dies ist ein charakteristisches Merkmal des Produkts.

Поскольку плиты упаковываются в произвольном порядке, Caesar не дает никаких предварительных гарантий по типу рисунка, имеющегося в каждой отдельной упаковке. У плит может наблюдаться минимальная нестыковка сплошного рисунка, которая должна считаться особенностью изделия.

RT Rettificato, squadrato, monocalibro. - Rectified, squared, one caliber. - Rectifié, mis d'equerre et monocalibre. - Rektifiziert, rechtwinkelig und Ein kaliber. - Ректифицированный, одного калибра.

Project Evolution

PROJECT EVOLUTION

| SERIE | COLORE | 160x320 cm 63"x126" 6 mm | | | 120x278 cm 47 1/8"x109 1/8" 6 mm | | |
|-----------------|-------------------|--------------------------------|---------|---------|----------------------------------------|---------|---------|
| | | LUCIDATO RT | SILK RT | MATT RT | LUCIDATO RT | SILK RT | MATT RT |
| ALCHEMY | Tc.Mint | | | ● | | | ● |
| | Navy | | | | | | ● |
| | Copper | | | | | | ● |
| ANIMA | Statuario Venato | ● | ● | | ● | ● | |
| | Calacatta Oro | ● | ● | | ● | ● | |
| | Graphite | | | | | ● | |
| | Nero Atlante | ● | ● | | ● | | |
| ANIMA EVER | Magnificent White | | | | ● | | |
| | Luxury Arabesque | | | | ● | | |
| | Apuan Gold | | ● | | | | |
| | Sage Green | | | | ● | | |
| | Royal Onyx | | | | ● | | |
| ANIMA FUTURA | Golden White | | | | ● | | |
| | Majestic White | | | | ● | | |
| | Amazing Silver | | | | ● | | |
| | Unique Black | | | | ● | | |
| | Keen Grey | | | | ● | | |
| JOIN | Glare | | | | | | ● |
| | Wing | | | | | | ● |
| | Levity | | | | | | ● |
| PORTRAITS | Comblanchien | | | | | | ● |
| | Faro | | | ● | | | ● |
| PRIMA | Kirkby | | | ● | | | ● |
| | Concrete | | | | | | ● |
| RELATE FLAME | Blizzard | | | | | | ● |
| | Mine | | | | | | ● |
| | Reef | | | | | | ● |
| | Moss | | | | | | ● |
| SHAPES OF ITALY | Blaze | | | | | | ● |
| | Iulia | | | | | | ● |
| TINTE UNITE | PureWhite | | | ● | | | |

* Lastra disponibile anche in spessore 12 mm, formato 162x324, non rettificata e non squadrata. - Slab also available with a thickness of 12 mm, size 162x324, non-rectified and non-wedged. - Dalle disponible également en 12 mm d'épaisseur, format 162x324, non rectifiée et non écarriée. / Die Platte ist auch im Format 162x324 mit 12 mm Stärke, nicht rektifiziert und nicht abgekantet, erhältlich. - Плита предлагается также с толщиной 12 мм, в формате 162x324, нешлифованная и необременная.

| IMBALLI - PACKAGING - CONDITIONNEMENT - VERPACKUNGS-EINHEITEN - УПАКОВКА | | | | | | | |
|--------------------------------------------------------------------------|------------------|------------------------------------------|--------|--------|---------------------------|-------|----------|
| Formato - Size - Format - Формат | | Scatola - Box - Boîte - Karton - Коробка | | | Pallet - Palette - Палета | | |
| CM | INCHES | PZ | MQ | KG | SC | MQ | KG |
| 160x320 | 63"x126" | 1 | 5,12 | ~78,00 | 14 | 71,68 | ~1092,00 |
| 120x278 | 47 1/8"x109 1/8" | 1 | 3,3221 | ~49,56 | 18 | 59,79 | ~892,08 |

RT Rettificato, squadrato, monocalibro. - Rectified, squared, one caliber. - Rectifié, mis d'équerre et monocalibre. - Rektifiziert, rechtwinkling und Ein kaliber. - Ректифицированный, одна калибра.

L'utilizzo della finitura LUCIDATO e SILK è limitato ai rivestimenti e alla posa a pavimento in ambito residenziale, o comunque in aree scarsamente sollecitate, evitando in ogni caso il contatto diretto con aree esterne o nelle quali siano richieste prestazioni antiscivolo. Le finiture LUCIDATO e SILK sono il risultato di particolari lavorazioni meccaniche e può presentare occasionali puntinature e avvallamenti, così come disuniformità nella lucentezza. Tali peculiarità sono da intendersi come caratteristiche integranti dei prodotti, allo scopo di ottenere una maggiore naturalezza. - The use of the LUCIDATO and SILK finishes is limited to wall cladding and floor application in residential venues and in spaces subject to low foot traffic, avoiding the direct contact with outdoor areas which require anti-slip features. The LUCIDATO and SILK finishes are the result of a special mechanical process and can manifest small dots or hollows as well as a non-uniform shine all over the surface. These particularities are to be considered as intrinsic features of the product which give them a more natural appeal. - L'utilisation de la finition LUCIDATO et SILK est limitée aux revêtements et à la pose au sol dans des environnements résidentiels, ou dans tous les cas dans des aires faiblement sollicitées, en évitant ainsi le contact direct avec les aires extérieures ou dans lesquelles sont requises des prestations antidérapantes. Les finitions LUCIDATO et SILK sont le résultat de façonnages mécaniques particuliers et peuvent présenter d'éventuelles petites taches ou de légers affaissements de brillance. Ces particularités doivent être considérées comme des caractéristiques du produit à part entière. Le façonnage de cette finition a justament pour but d'obtenir cet effet naturel et difforme. - Die Verwendung der Version LUCIDATO und SILK ist auf Wand und Boden im Wohnbereich bzw. in wenig belasteten Bereichen beschränkt, und in jedem Fall ist der direkte Kontakt mit Außenbereichen sowie mit Rutschfestigkeit erfordernden Bereichen zu vermeiden. Die Versionen LUCIDATO und SILK sind Ergebnisse besonderer maschineller Bearbeitungen; sie können gelegentlich Nadelstiche und Krater sowie uneinheitlichen Glanz aufweisen. Es handelt sich hierbei um Produktmerkmale, mit denen eine besonders natürliche Wirkung erzeugt wird. - Плитки с поверхностью LUCIDATO и SILK можно укладывать только на стены и полы в жилых помещениях или, во всяком случае, в контекстах, где покрытие подвергается невысокой эксплуатационной нагрузке. Не рекомендуется укладывать их на улице или на участках, где от покрытий требуется высокое сопротивление скольжению. Поверхности LUCIDATO и SILK получаются в результате специальной механической обработки и могут иметь небольшие наволки, углубления или неравномерность блеска. Эти особенности являются характеристикой изделий и имеют целью придать им большую натуральность.

Si raccomanda l'utilizzo di una fuga di 2/3 mm al fine di semplificare le operazioni di posa e ottimizzare la naturalezza del risultato finale. - We recommend you a 2/3 mm grout joint to simplify the laying and optimize the naturalness of the final result. - Un joint de 2/3 mm est conseillé afin de simplifier les opérations de pose et optimiser l'effet naturel du résultat final. - Es wird empfohlen mit einer Fuge von 2/3 mm zu arbeiten, um am Ende den Verlegevorgang zu vereinfachen und die bestmögliche Natürlichkeit der Arbeit zu erzielen. - Для облегчения операций укладки и повышения натуральности вида конечного результата рекомендуется выполнять шов шириной 2-3 мм.

Al fine di facilitare la manutenzione ordinaria si raccomanda di effettuare un lavaggio acido dopo 48 ore dalla stuccatura con un acido specifico per grès porcellanato. - In order to favour the ordinary maintenance procedures, it is recommended to carry out an acid wash of the surface after 48 hours from grout filling using an acid agent specific for porcelain stoneware tiles. Afin de faciliter l'entretien ordinaire de votre carrelage, nous vous conseillons de le laver 48 heures après le colmatage des joints, avec un acide spécifique pour grès cérame. - Um die Instandhaltung zu erleichtern, empfiehlt es sich 48 Stunden nach der Stuckatur mit einer sauren Lösung speziell für Feinsteinzeug zu waschen. - Чтобы упростить уход за плиткой, спустя 48 часов после затирки швов рекомендуется выполнять обработку кислотным продуктом, пригодным для керамогранита.

CARATTERISTICHE TECNICHE

TILE PERFORMANCE DATA - NOTES TECHNIQUES - TECHNISCHE AUSKÜNFTE - ТЕХНИЧЕСКАЯ ХАРАКТЕРИСТИКА

Classificazione secondo EN ISO 14411 ISO 13006 annesso G gruppo Bla con Ev ≤0,5 % - Classification in accordance with EN ISO 14411 ISO 13006 annex G standards Bla with Ev ≤ 0,5% - Classification selon EN ISO 14411 ISO 13006 annexe G groupe Bla avec Ev ≤0,5% - Klassifizierung gemäß EN ISO 14411 ISO 13006 anlage G Gruppe Bla mit Ev ≤0,5% - Классификация в соответствии с EN ISO 14411 ISO 13006, приложение G, стандарт Bla, где Ev ≤0,5%

| | CARATTERISTICA TECNICA TECHNICAL CHARACTERISTIC CARACTERISTIQUE TECHNIQUE TECHNISCHE DATEN ТЕХНИЧЕСКАЯ ХАРАКТЕРИСТИКА | METODO DI PROVA TESTS METHOD METHODE D'ESSAI TESTMETHODE МЕТОД ИСПЫТАНИЯ | VALORE * MEDIO "CAESAR" AVERAGE "CAESAR" VALUE * VALEUR * MOYEN "CAESAR" "CAESAR" DURCHSCHNITTSWERT * СРЕДНЕЕ ЗНАЧЕНИЕ "CAESAR" * | | | |
|------------------------------------------------------------------------------------------------------------------------------------------------------------------------------------------------------------------------------------------|-----------------------------------------------------------------------------------------------------------------------------------|--------------------------------------------------------------------------------------|------------------------------------------------------------------------------------------------------------------------------------------------------------------------------|------------------------------------------------------------------------|---------------------------------------------------------------------------------------------------------------|------------------------------------------------------------------------------------------------------------------------------------------------------------------------------|
| | | | ANIMA - ANIMA EVER ANIMA FUTURA DECO SOLUTIONS Lucidato GL | ANIMA - ANIMA EVER Silk | ALCHEMY - DECO SOLUTIONS JOIN - PORTRAITS PRIMA - RELATE FLAME SHAPES OF ITALY - TINTE UNITE Matt | DECO SOLUTIONS Matt GL |
| Dimensione - Size Dimension - Abmessungen - Размер | | ISO 10545-2 | Conforme - In accordance Conforme - Erfüllt - Соответствует | Conforme - In accordance Conforme - Erfüllt - Соответствует | Conforme - In accordance Conforme - Erfüllt - Соответствует | Conforme - In accordance Conforme - Erfüllt - Соответствует |
| Assorbimento d'acqua* - Water absorption* Absorption d'eau* - Wasseraufnahme* % Поглощения воды* | | ISO 10545-3 | ≤ 0,1% | ≤ 0,1% | ≤ 0,1% | ≤ 0,1% |
| Resistenza alla flessione* - Bending strength* Résistance à la flexion* - Biegezugfestigkeit* - Упругость* | | ISO 10545-4 | Conforme - In accordance Conforme - Erfüllt - Соответствует | Conforme - In accordance Conforme - Erfüllt - Соответствует | Conforme - In accordance Conforme - Erfüllt - Соответствует | Conforme - In accordance Conforme - Erfüllt - Соответствует |
| Resistenza all'urto - Impact resistance Résistance au choc - Schlagfestigkeit - Ударопрочность | | ISO 10545-5 | ≥ 0,80 | ≥ 0,80 | ≥ 0,80 | ≥ 0,80 |
| Resistenza all'abrasione profonda* - Deep scratch resistance* Résistance à l'abrasion profonde* - Widerstand gegen Tiefenverschleiß* - Устойчивость глубокому истиранию* | | ISO 10545-6 | - | Conforme - In accordance Conforme - Erfüllt - Соответствует | Conforme - In accordance Conforme - Erfüllt - Соответствует | Conforme - In accordance Conforme - Erfüllt - Соответствует |
| Coefficiente di dilatazione termica lineare* - Thermal linear expansion coefficient* - Coefficient de dilatation thermique linéaire* - Koeffizient der linearen thermischen Dehnung* Коэффициент линейного температурного расширения* | | ISO 10545-8 | ≈ 7 (10 ⁻⁶ °C ⁻¹) | ≈ 7 (10 ⁻⁶ °C ⁻¹) | ≈ 7 (10 ⁻⁶ °C ⁻¹) | ≈ 7 (10 ⁻⁶ °C ⁻¹) |
| Resistenza al cavillo - Cracking resistance Résistance aux craquelures - Haariß-Beständigkeit Устойчивость эмали к краquelю | | ISO 10545-11 | Conforme - In accordance Conforme - Erfüllt - Соответствует | - | - | Conforme - In accordance Conforme - Erfüllt - Соответствует |
| Resistenza all'attacco chimico ● - Resistance to chemical attack ● - Résistance à l'attaque chimique ● - Beständigkeit gegen Chemikalien ● - Устойчивость к химическому воздействию ● | | ISO 10545-13 | Resistente - Resistant Résistante - Beständig - Стойкий | Resistente - Resistant Résistante - Beständig - Стойкий | Resistente - Resistant Résistante - Beständig - Стойкий | Resistente - Resistant Résistante - Beständig - Стойкий |
| Resistenza alle macchie* - Resistance to stains* Nettoyabile - Leicht zu reinigen Устойчивость к образованию пятен* | | ISO 10545-14 | Pulibile - Cleanable Nettoyabile - Leicht zu reinigen Чистящийся | Pulibile - Cleanable Nettoyabile - Leicht zu reinigen Чистящийся | Pulibile - Cleanable Nettoyabile - Leicht zu reinigen Чистящийся | Pulibile - Cleanable Nettoyabile - Leicht zu reinigen Чистящийся |
| Resistenza allo scivolamento** - Slip resistance** Résistance au glissement** - Rutschhemmende Eigenschaft** Сопротивление скольжению** | | DIN 51130 DIN 51097 | - | - | R9 Matt | - |
| | | ▲ ANSI A326.3 | - | - | Wet DCOF ≥ 0,42 | - |
| Resistenza all'abrasione superficiale - Surface abrasion resistance - Résistance à l'abrasion superficielle - Widerstand gegen Oberflächenschleiß - Сопротивление на изгиб и истиланию на изломе | | EN ISO 10545-7 | Test disponibili in azienda Tests available at our company Tests disponibles en usine Prüfzeugnisse beim Werk erhältlich Протоколы испытаний хранятся в компании | - | - | Test disponibili in azienda Tests available at our company Tests disponibles en usine Prüfzeugnisse beim Werk erhältlich Протоколы испытаний хранятся в компании |
| Spessore nominale - Nominal Thickness Épaisseur nominale - Nominalstärke Номинальная толщина | | | 6 mm 160x320 - 120x278 GOLD MAGNOLIA 6 mm - 120x278 | 6 mm 160x320 - 120x278 | 6 mm 160x320 - 120x278 12 mm 162x324 | GOLD WILLOW 6 mm 120x278 JOIN DECO 6 mm 120x278 |

* Valori medi riferiti agli ultimi due anni di produzione e relativi alla finitura naturale del prodotto - Average values referred to the last two years of production and related to the matt finish of the product - Valeurs moyennes des deux dernières années de production et relatifs à la finition naturelle du produit - Durchschnittswerte, die sich auf die letzten zwei Produktionsjahre beziehen und auf die matte Oberfläche - Средние значения относятся к последним двум годам производства и натуральной отделке поверхности

** Valori relativi alla finitura naturale del prodotto ed a test effettuati da laboratori esterni accreditati, disponibili in azienda; ci rendiamo disponibili alla verifica dell'eventuale lotto interessato all'acquisto. - As far as values relating to the matt finish of the product and to tests carried out by certified external laboratories whose results are available upon request at Headoffice, we are willing to check the lot you are interested in purchasing. - Valeurs se référant à la finition naturelle du produit selon des tests effectués par des laboratoires extérieurs accrédités et à la disposition de toute personne intéressée auprès de nos bureaux; nous sommes disponibles pour le contrôle de l'éventuel lot concerné par l'achat. - Werte bezogen auf das natürliche Produktfinish und in anerkannten externen Labors geprüft, im Unternehmen erhältlich; für eventuelle Prüfungen der zu erwerbenden Warenposten stehen wir gern zur Verfügung. - Значения, касающиеся натуральных характеристик изделий и тестов, выполненных внешними авторизованными лабораториями, имеются в компании. Мы готовы выполнить проверку партии товара, которую намереваетесь приобрести.

• Per prodotti chimici di uso domestico e additivi per piscina. - For domestic chemicals and swimming pool additives. - Pour produits chimiques à usage domestique et additifs pour piscines. - Für chemische Produkte für den Hausgebrauch und Schwimmbadzusätze. - Для бытовых химикатов и дрваков для бассейнов.

▲ Valori wet DCOF specifici disponibili in azienda - Wet DCOF specific values available at the company - Valeurs wet DCOF spécifiques disponibles à l'usine - Prüferte Wet DCOF stehen im Werk zur Verfügung - Показатели wet DCOF доступны при запросе

Caesar raccomanda l'utilizzo a pavimento delle grandi lastre in spessore 6mm per le sole applicazioni in ambito residenziale, commerciale a traffico leggero e comunque in contesti ove non vi sia passaggio di carichi puntuali pesanti o transitò di carrelli a ruote dure. La gamma di grandi lastre in 6 mm di spessore è indicata per la posa su pavimenti prestistenti: è possibile effettuare la posa su vecchi pavimenti o rivestimenti in marmo, pietra naturale, ceramica, senza la necessità di demolire la pavimentazione sottostante. ATTENZIONE: è sconsigliata la posa di queste lastre direttamente sul massetto. Questo perché la posa su massetto è fortemente condizionata dall'esecuzione ottimale del massetto stesso, dalla sua completa stagionatura, dal rispetto degli opportuni giunti di dilatazione nonché dalla posa effettuata a "regola d'arte". Pertanto, in questi casi, Caesar suggerisce l'utilizzo di grès porcellanato in spessore tradizionale. - Caesar recommends the installation of 6 mm thick extra large slabs only in the following conditions: residential environments, commercial environments that are subject to light tra c and in any case in contexts where there is no regular passage of heavy loads or circulation of trolleys with hard wheels. The range of 6 mm thick extra large slabs is suitable for installation on existing foors: the slabs can be installed on old floors or marble, natural stone and ceramic claddings, without the need to demolish the existing underlying floor. ATTENTION: it is not recommended to install these slabs on a screed directly, since the results of installation strictly relate to the condition - excellent - of the screed, to its seasoning, to the provision of expansion joints, as well as to perfect installation in accordance to "the rules of the trade". In these cases, Caesar recommends the use of porcelain stoneware with a conventional thickness. - Pour le revêtement des sols, Caesar conseille l'utilisation des grandes dalles d'une épaisseur de 6 mm uniquement pour le secteur résidentiel, les zones commerciales à trafic léger et, quoi qu'il en soit, dans des contextes ne prévoyant pas le passage de charges lourdes ponctuelles ou de chariots à roues dures. La gamme de grandes dalles d'une épaisseur de 6 mm est indiquée pour la pose sur des sols préexistants - il est possible d'é ectuer la pose sur de vieux sols ou des revêtements en marbre, pierre naturelle, céramique sans devoir pour autant démolir le sol sous-jacent. ATTENTION il est déconseillé de poser ces dalles directement sur la chape. En e et une pose sur chape exécutée dans les « règles de l'art » dépend beaucoup de l'exécution optimale de la chape elle-même, de son séchage complet et du respect du positionnement des joints de dilatation. - Dans ces cas, Caesar suggère l'utilisation d'un grès cérame à épaisseur traditionnelle. Caesar empfiehlt die Verwendung der großen Platten in 6 mm Stärke als Bodenbelag nur für den Wohnungsbau, für nur leicht beanspruchte Gewerbeobjekte und in jedem Fall nur in Bereichen, in denen keine konzentrierten, schweren Lasten vorhanden sind bzw. die nicht von Transportwagen mit Hartgummirädern befahren werden. Die Palette der 6 mm starken, großen Platten eignet sich für die Verlegung über bereits vorhandenen Bodenbelägen: Eine Überverlegung auf bestehenden Bodenbelägen aus Marmor, Naturstein, Keramik ist möglich, ohne den vorhandenen Belag demolieren zu müssen. ZUR BEACHTUNG: Von der Verlegung dieser Platten direkt auf den Estrich wird abgeraten. Grund hierfür ist, dass die Verlegung auf Estrich in hohem Maße von der perfekten Ausführung des Estrichs selbst abhängt, von seiner vollständigen Aushärtung, von der korrekten Ausführung der Dehnungsfugen sowie von der „fachgerechten Verlegung“ im Allgemeinen. In diesen Fällen emp ehlt Caesar daher die Verwendung von Feinsteinzeug in traditioneller Stärke. - Caesar empfiehlt nämlich eine normale Dicke für die Verlegung von großformatigen Platten mit einer Stärke von 6 mm ausschließlich in wohnlichen und kommerziellen Objekten mit einer geringen Fußgängerfrequenz und in jedem Fall dort, wo kein regelmäßiger Transport von schweren Lasten oder der Einsatz von Transportfahrzeugen mit Hartgummirädern erforderlich ist. Caesar empfiehlt die Verwendung von Feinsteinzeug mit einer konventionellen Dicke. - Если вы планируете использовать керамогранит толщиной 6 мм для облицовки из мрамора, натурального камня, керамики, без необходимости разбора уже существующих покрытий. ВНИМАНИЕ: не рекомендуется укладывать этик плит непосредственно на стяжку. Это вызвано тем, что на укладку на стяжку сильно влияют качественные изготовление стяжки, ее полная выдержка, присутствие всех необходимых расширительных швов, а также безупречное выполнение самой укладки. Поэтому, для такой укладки Caesar рекомендует использовать керамогранит обычной толщины.

Le tonalità dei campioni sono da considerarsi puramente indicative. - Tones of samples are indicative. - Les tonalités des échantillons sont purement indicatives. Die farbtöne der Muster sind als rein indicativ zu betrachten. - Тона образцов ориентировочные.

Olos

Porcelain surfaces for design and furniture



The Ancient Greek word ὅλος, meaning “whole, entire, complete”, identifies a whole, the value of which is greater than the sum of elements composing it. Caesar has created the Olos trademark to encourage the use of ceramic slabs for an entire project. Top level technical features, aesthetic prestige and a particularly broad range make Caesar materials the optimal finishing material for furniture in both residential and commercial contexts.

The Ancient Greek word ὅλος, meaning “whole, entire, complete”, identifies a whole, the value of which is greater than the sum of elements composing it. Caesar has created the Olos trademark to encourage the use of ceramic slabs for an entire project. Top level technical features, aesthetic prestige and a particularly broad range make Caesar materials the optimal finishing material for furniture in both residential and commercial contexts.

Le mot grec ὅλος indique un tout, dont la valeur globale dépasse la somme des éléments qui la composent. Caesar a donné vie à la marque Olos afin de valoriser l'utilisation des dalles en céramique dans un projet de décoration global. Des caractéristiques techniques de premier ordre, une grande valeur esthétique et l'étendue de la gamme font des matériaux Caesar une finition optimale pour des projets d'aménagement destinés aux différentes pièces du résidentiel et du commercial.

Der griechische Begriff ὅλος, „das Ganze“, steht für eine Gesamtheit, dessen Wert insgesamt höher ist als die Summe seiner einzelnen Elemente. Mit der neuen Marke Olos zeigt Caesar die Verwendungsmöglichkeiten der Keramikplatten von Caesar für das gesamte Designprojekt auf. Erstklassige technische Eigenschaften, hohes optisches Prestige und eine umfassende Produktpalette machen die Materialien von Caesar zur perfekten Verkleidung von Einrichtungselementen in allen Bereichen von Wohnungs- und Gewerbebauprojekten.

Греческое слово ὅλος (“все”) обозначает совокупность, общее значение которой превышает сумму составляющих ее элементов. Caesar создала бренд Olos для стимулирования использования керамических плит при составлении всего проекта оформления интерьеров. Технические характеристики высшего уровня, престижный внешний вид и широчайший охват ассортимента превращают продукцию Caesar в оптимальный отделочный материал для изготовления предметов интерьера, предназначенных для разных помещений как в жилых, так и в торговых проектах.



Info
Resources
Tools



Floor: ANIMA FUTURA GOLDEN WHITE 60x120 MATT RT
Wall: ANIMA FUTURA KEEN GREY 120x278 LUCIDATO RT, JOIN GLARE 120x278 MATT RT
Furniture by OLOS: ANIMA FUTURA GOLDEN WHITE 120x278 LUCIDATO

L'offerta

The range

UN PARTNER AFFIDABILE PER INDUSTRIA DEL MOBILE E ARTIGIANI.

L'offerta di Olos si rivolge specificamente a utenti professionali, allestitori e contractor, per illustrare le potenzialità delle lastre in grès per realizzare -su scala industriale o artigianale- piani di lavoro e mobili per bagno, cucina, tavoli, arredi, allestimenti su misura e altro ancora.

A RELIABLE PARTNER FOR THE FURNITURE INDUSTRY AND FOR ARTISANS

The Olos range is addressed in particular to professional users, fitters and contractors, to exploit the potential of stoneware slabs and create - on an industrial or artisanal scale - work tops and furniture for bathrooms, kitchens, tables, furniture, customised set-ups and much more.

UN PARTENAIRE SOLIDE POUR L'INDUSTRIE DU MEUBLE ET LES ARTISANS.

L'offre d'Olos s'adresse en particulier aux professionnels, décorateurs et entrepreneurs, pour dévoiler le potentiel des dalles en grès afin de réaliser - à l'échelle industrielle ou artisanale - des plans de travail et des meubles de salle de bains et de cuisine, des tables, des aménagements sur mesure et bien d'autres créations.

EIN ZUVERLÄSSIGER PARTNER FÜR HANDWERK UND MÖBELINDUSTRIE.

Das Angebot von Olos wendet sich unmittelbar an Fachkunden, Raumausstatter und Contracting-Firmen, um das ganze Potenzial der Feinsteinzeugplatten für die Herstellung - auf industrieller oder handwerklicher Ebene - von Arbeitsplatten und Möbeln für Bad und Küche, Tischen, Mobiliar, Einrichtungselementen nach Maß und vielem mehr zu illustrieren.

НАДЕЖНЫЙ ПАРТНЕР ДЛЯ МЕБЕЛЬНОЙ ПРОМЫШЛЕННОСТИ И МЕБЕЛЬЩИКОВ.

Продукция Olos специально предназначена для профессиональных пользователей, оформителей и подрядчиков, которые могут использовать потенциал керамогранитных плит для крупносерийного или мелкосерийного выпуска столешниц и мебели для ванной комнаты и кухни, столов, предметов мебелировки, оформлений на заказ и многих других целей.

Vantaggi . Advantages



Resiste alle macchie.
Stain resistant.
Résiste aux taches.
Fleckenbeständig.
Стойкость к пятнам.



Resiste agli agenti chimici di uso domestico e industriale *1.
Household and industrial chemicals resistant.
Résiste aux agents chimiques à usage domestique et industriel.
Beständig gegen Industrie- und Haushaltschemikalien.
Выдерживает воздействие бытовых и промышленных химических веществ.



Superficie idonea al contatto con alimenti.
Surface suitable for contact with foodstuffs.
Surface convenant au contact alimentaire.
Lebensmittelechte Oberfläche.
Материал пригоден для контакта с пищевыми продуктами.



Idoneo per ambienti interni ed esterni.
Suitable for indoor and outdoor installation.
Parfait aussi bien à l'intérieur qu'à l'extérieur.
Für Innen- und Aussen.
Подходит для внутренних и наружных пространств.



Resiste a graffi e abrasioni *2.
Scratch and abrasion resistant.
Résiste aux rayures et aux abrasions.
Kratz- und Abriebfest.
Противостоит царапинам и износу.



Colori inalterabili alla luce
Colourfast.
Couleurs inaltérables à la lumière.
Lichtechte Farben.
Невыгорающие цвета.



Resiste a umidità e muffe.
Damp and mould resistant.
Résiste à l'humidité et aux moisissures.
Beständig gegen Feuchtigkeit und Schimmel.
Стойкость к влаге и образованию плесени.



Facile da pulire e igienizzare.
Easy to clean and sanitise.
Facile à nettoyer et à désinfecter.
Einfach zu reinigen und zu desinfizieren.
Легко чистится и гигиенично обрабатывается.



Non rilascia sostanze nocive per la salute (voc free).
Does not release harmful substances (voc free).
N'émet aucune substance nocive pour la santé (sans cov).
Setzt keine gesundheitsschädlichen Substanzen frei (VOC-frei).
Не выделяет вредных для здоровья веществ (без лос).



Planare e stabile nel tempo.
Flat and stable over time.
Planaire et stable dans le temps.
Eben und auf dauer Stabil.
Плоскостность и неизменность в течение времени.



Non rilascia formaldeide.
Does not release formaldehyde.
N'émet pas de formaldéhyde.
Setzt kein Formaldehyd frei.
Не выделяет формальдегида.



Ecologico e riciclabile
Green and recyclable.
Écologique et recyclable.
Ökologisch und recyclebar.
Экологичность и перерабатываемость.



Pregio estetico.
Prestigious appearance.
Valeur esthétique.
Hohes optisches Prestige.
Удачная эстетика.



Resiste al gelo.
Frostproof.
Résiste au gel.
Frostbeständig.
Выдерживает низкие температуры.



Resiste al calore e alle alte temperature.
Heat and high temperature resistant.
Résiste à la chaleur et aux hautes températures.
Beständig gegen Hitze und hohe Temperaturen.
Выдерживает тепло и высокие температуры.



Coordinabile con pavimenti e rivestimenti.
Can be matched to floors and walls.
Peut être coordonné avec les revêtements de sols et de murs.
Auf Wand- und Bodenbeläge abstimbar.
Сочетается с напольной и облицовочной плиткой.



Non contiene plastica, vernici, resine.
Does not contain plastic, paint, resin.
Ne contient ni plastiques, ni vernis, ni résines.
Frei von Kunststoffen, Lacken und Harzen.
Не содержит пластмасс, красок и смол.

*1 Per prodotti chimici di uso domestico e additivi per piscina.
For domestic chemicals and swimming pool additives.

*2 Sulla base delle normative 10545-6 (finiture Naturale e Silk) e ISO 10545-7 (Finitura Lucidata).
In compliance with the ISO 10545-6 (Matt and Silk finishes) and ISO 10545-7 (Lucidato finish) standards.

Applicazioni . Applications

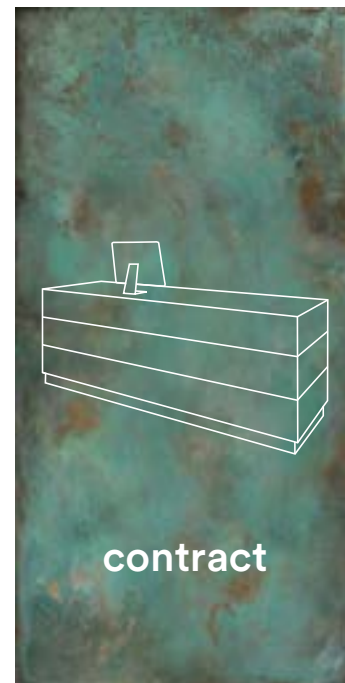
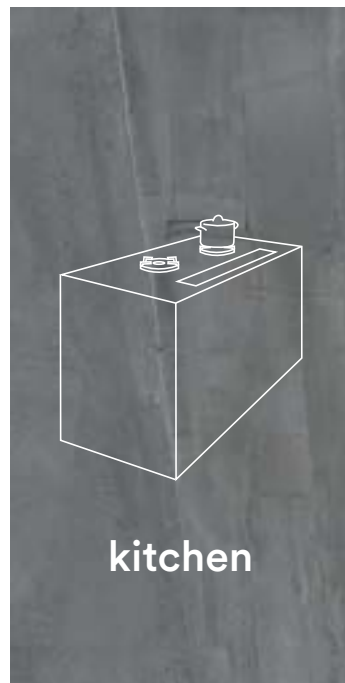
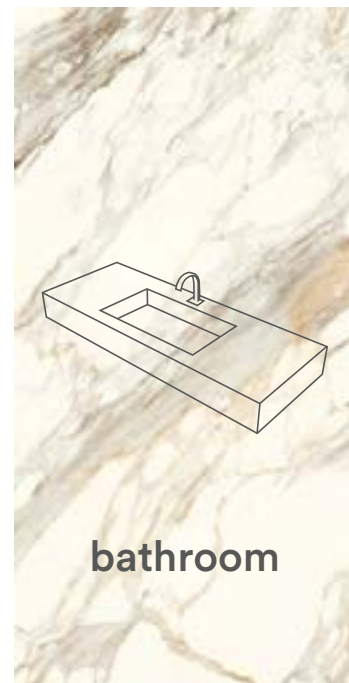

Superfici OLOS
OLOS Surfaces - Surfaces OLOS
OLOS-Flächen - Плиты OLOS

+

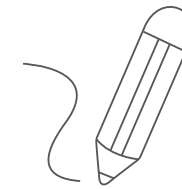

La tua creatività
Your Creativity - Votre créativité
Ihre Kreativität - Ваше творчество

+

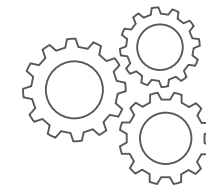

Lavorazione
Processing - Usinage
Bearbeitung - Обработка

=

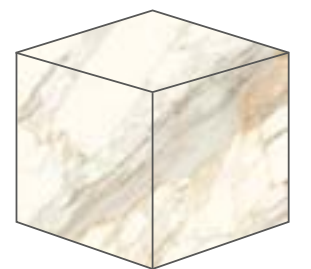

Arredo finito
Finished Furniture - Aménagement fini
Fertige Einrichtung - Готовый предмет интерьера

Alcuni esempi di possibili impieghi delle lastre fornite da Ceramiche Caesar. L'ideazione, produzione e installazione di top, arredi e realizzazioni su misura è affidata alla creatività e capacità tecnica delle aziende partner, a cui Caesar fornisce le lastre. - Some examples for use of Ceramiche Caesar slabs. The design, production and installation of tops, furniture and customised set-ups is entrusted to the creativity and technical skill of partner companies, to which Caesar supplies its slabs. - Quelques exemples d'utilisation des dalles fournies par Ceramiche Caesar. La conception, la production et l'installation de plateaux ainsi que les aménagements et les réalisations sur mesure sont le fruit de la créativité et de la technicité des entreprises partenaires, auxquelles Caesar fournit ses dalles. - Einige Beispiele für mögliche Verwendungen der Platten von Ceramiche Caesar. Die Ideen, die Anfertigung und Montage von Arbeitsplatten, Möbeln und Einrichtungselementen nach Maß liegen bei den Partnerfirmen, denen Caesar die Platten liefert, ganz nach ihrer Kreativität und technischen Kapazität. - Представляем несколько примеров возможного применения плит производства Ceramiche Caesar. Разработка, изготовление и установка столешниц, предметов интерьера и изделий на заказ является результатом творческих идей и технических навыков партнерских компаний, которым Caesar поставляет свои плиты.

Alcune possibilità di utilizzo

Some possibilities for use

Bathroom

Piano lavabo, mobile bagno, piatto doccia, mensole, vasca.

Washbasin tops, bathroom cabinets, showers, shelves, baths.

Plan vasque, meuble de salle de bains, receveur de douche, étagères, baignoire.

Waschtisch, Badezimmerschrank, Duschwanne, Wandablage, Wanne.

Столешница умывальника, тумба для ванной, душевой поддон, полки, ванна.



Kitchen

Piano di lavoro, vasca lavello, tavolo, mensole.

Work tops, kitchen sinks, tables, shelves.

Plan de travail, plan pour évier, table, étagères.

Arbeitsplatte, Spülbecken, Tisch, Wandablage.

Рабочая столешница, кухонная мойка, стол, полки.



Alcune possibilità di utilizzo

Some possibilities for use

Living

Piani per tavoli e tavolini da interno e esterno, panche, mensole, quinte.

Table tops and coffee tables for interiors and exteriors, benches, shelves, partitions.

Plateaux de tables et tables basses pour l'intérieur et l'extérieur, bancs, étagères, cloisons de séparation.

Platten Für Tische und Couchtische für Innen und Aussen, Bänke, Wandablagen, Kulissen.

Рабочая Столешница, Кухонная Мойка, Стол, Полки.



Contract

Arredamenti su misura per hotel e negozi, quali moduli bagno, reception, mensole, panche, tavoli.

Customised furniture for hotels and shops, such as modules for bathrooms, reception desks, shelves, benches, tables.

Aménagements sur mesure pour hôtels et magasins, comme les modules de toilettes ou salles de bains, réception, étagères, bancs, tables.

Massgeschneiderte einrichtungen für Hotels und Geschäfte, wie Badmodule, Rezeption, Wandablagen, Bänke, Tische.

Столешницы для столов и столиков для установки в помещении или на улице, скамьи, полки, кулисы.



Spessori

Thickness

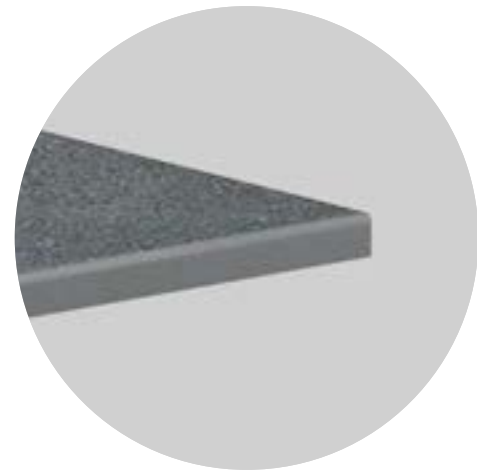

6 mm

Le lastre in spessore 6 mm si prestano facilmente a operazioni quali tagli e fori e lavorazioni sui bordi. Il peso ridotto facilita il trasporto e la movimentazione. Sono idonee a rivestire elementi di arredo con un supporto interno.

Slabs with a 6-mm thickness make cutting, drilling and edge processing easy. They are light and easy to transport and handle. They are ideal for covering furniture with internal supports.

Les dalles de 6 mm d'épaisseur sont faciles à découper et à percer et leurs chants faciles à travailler. Leur poids réduit facilite leur transport et leur manutention. Elles sont idéales pour habiller des éléments décoratifs avec un support interne.

Die 6 mm starken Platten lassen sich mühelos schneiden, bohren und an den Kanten bearbeiten. Das geringe Gewicht erleichtert Transport und Handhabung. Eignen sich zur Verkleidung von Einrichtungs-elementen.

На плитах толщиной 6 мм можно легко выполнять такие операции, как резка, сверление отверстий, обработка кромок. Они обладают низким весом, что облегчает их перевозку и обращение с ними. Подходят для облицовки предметов интерьера, налагая их на внутреннюю конструкцию.

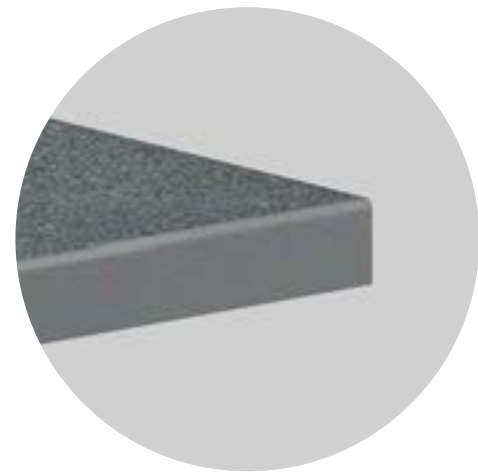

12 mm

Lo spessore 12 mm conferisce alle lastre una elevata resistenza, che ne consente l'utilizzo anche per tavoli e piani di lavoro non accoppiati. Le lavorazioni sul bordo sono ben visibili ed esaltate dallo spessore.

The 12-mm thickness offers a very high resistance. These slabs can be used as tables and tops without a supporting material. Edge processing is very visible and enhances the thickness.

Leur épaisseur de 12 mm assure aux dalles une forte résistance qui permet de les utiliser y compris pour des tables et des plans de travail sans support. Les usinages sur le chant sont bien visibles et mis en valeur par l'épaisseur.

Die Platten in 12 mm Stärke sind hochbeständig und können auch direkt als Material für Tische und Arbeitsflächen dienen. Die Kantenbearbeitungen sind gut sichtbar und werden durch die Stärke akzentuiert.

Толщина в 12 мм придает плитам высокую прочность, благодаря чему они могут использоваться для изготовления столов и рабочих столешниц без применения опорных конструкций. Обработка кромок хорошо заметна и особенно подчеркивается толщиной плит.

È compito del progettista verificare se la lastra necessita di un supporto, in funzione dell'applicazione specifica.

The designer must check if the slabs needs a support, based on its specific application.

Il appartient au concepteur de vérifier si la dalle, en fonction de sa destination spécifique, doit reposer sur un support.

Für die Prüfung der vom Verwendungszweck abhängigen Notwendigkeit einer Unterlage ist der Planer zuständig.

В зависимости от конкретного применения проектировщик обязан проверять необходимость опорного материала для плиты.

Finiture

Finishes

Lucidato

La lucidatura crea una superficie brillante, riflettente e omogenea.

The lucidato finish creates a glossy, reflecting and smooth surface.

Le polissage crée une surface brillante, réfléchissante et homogène.

Die Politur erzeugt eine glänzende, reflektierende und gleichmässige Oberfläche.

Полировка создает глянцевую, отражающую и однородную поверхность.



Silk

La finitura silk è liscia, vellutata e setosa al tatto, con uno speciale effetto di opacità.

The silk finish is smooth, velvety and silky to touch, with a special matt appearance.

La finitura silk est lisse, veloutée et soyeuse au toucher, avec un effet spécial mat.

Silk ist eine glatte Oberfläche, die sich samtig und seidig anfühlt; mit einem besonderen matt-Effekt.

Отделка silk является гладкой, бархатистой и шелковистой на ощупь, обладает особым матовым эффектом.

Matt

Una superficie opaca e materica; solitamente liscia o con leggeri movimenti della superficie.

A matt and substantial surface: generally smooth or with subtle textures.

Une surface mate et matériq : généralement lisse ou avec de légers mouvements en surface.

Matte und stoffliche Oberfläche: in der Regel glatt oder mit leicht bewegter Oberfläche.

Как правило, эта матовая и фактурная поверхность обладает гладкой или слегка неравномерной поверхностью.



Esempi di lavorazione dei bordi

Examples of edge processing

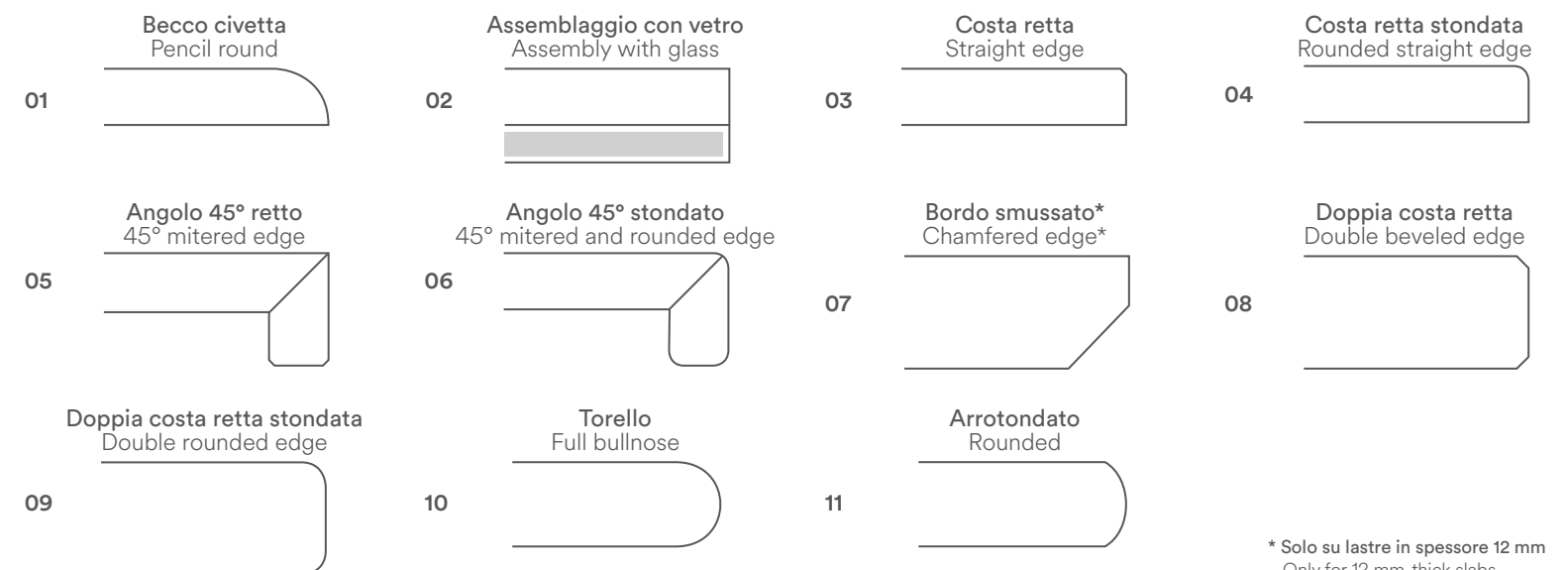

* Solo su lastre in spessore 12 mm
Only for 12 mm-thick slabs

| SERIE | COLORE | 160x320 cm 63"x126" 6 mm | | | 120x278 cm 47 1/8"x109 7/16" 6 mm | | |
|-----------------|-------------------|--------------------------------|---------|---------|-----------------------------------------|---------|---------|
| | | LUCIDATO RT | SILK RT | MATT RT | LUCIDATO RT | SILK RT | MATT RT |
| ALCHEMY | Tc.Mint | | | ● | | | ● |
| | Navy | | | | | | ● |
| | Copper | | | | | | ● |
| ANIMA | Statuario Venato | ● | ● | | ● | ● | |
| | Calacatta Oro | ● | ● | | ● | ● | |
| | Graphite | | | | | | ● |
| | Nero Atlante | ● | ● | | ● | ● | |
| ANIMA EVER | Magnificent White | | | | ● | | |
| | Luxury Arabesque | | | | ● | | |
| | Apuan Gold | | ● | | ● | | |
| | Sage Green | | | | ● | | |
| | Royal Onyx | | | | ● | | |
| ANIMA FUTURA | Golden White | | | | ● | | |
| | Majestic White | | | | ● | | |
| | Amazing Silver | | | | ● | | |
| | Unique Black | | | | ● | | |
| | Keen Grey | | | | ● | | |
| | Crystal Delight | | | | ● | | |
| JOIN | Pink Onyx | | | | ● | | |
| | Glare | | | | | | ● |
| | Wing | | | | | | ● |
| PORTRAITS | Levity | | | | | | ● |
| | Comblanchien | | | | | | ● |
| | Faro | | | | | | ● |
| PRIMA | Kirkby | | | ● | | | ● |
| | Concrete | | | | | | ● |
| RELATE FLAME | Blizzard | | | | | | ● |
| | Mine | | | | | | ● |
| | Reef | | | | | | ● |
| | Moss | | | | | | ● |
| SHAPES OF ITALY | Blaze | | | | | | ● |
| | Iulia | | | | | | ● |
| TINTE UNITE | PureWhite | | | ● | | | |

* Lastra disponibile anche in spessore 12 mm, formato 162x324, non rettificata e non squadrata. - Slab also available with a thickness of 12 mm, size 162x324, non-rectified and non-wedged. - Dalle disponible également en 12 mm d'épaisseur, format 162x324, non rectifiée et non équarrie. / Die Platte ist auch im Format 162x324 mit 12 mm Stärke, nicht rektifiziert und nicht abgekannt, erhältlich. - Плита предлагается также с толщиной 12 мм, в формате 162x324, нешлифованная и необрезанная.

| IMBALLI - PACKAGING - CONDITIONNEMENT - VERPACKUNGS-EINHEITEN - УПАКОВКА | | | | | | | |
|--------------------------------------------------------------------------|-------------------|------------------------------------------|--------|--------|---------------------------|-------|----------|
| Formato - Size - Format - Формат | | Scatola - Box - Boîte - Karton - Коробка | | | Pallet - Palette - Палета | | |
| CM | INCHES | PZ | MQ | KG | SC | MQ | KG |
| 160x320 | 63"x126" | 1 | 5,12 | ~78,00 | 14 | 71,68 | ~1092,00 |
| 120x278 | 47 1/8"x109 7/16" | 1 | 3,3221 | ~49,56 | 18 | 59,79 | ~892,08 |

RT Rettificato, squadrato, monocalibro. - Rectified, squared, one caliber. - Rectifié, mis d'équerre et monocalibre. - Rektifiziert, rechtwinkelig und Ein kaliber. - Ректифицированный, одного калибра.

Per maggiori informazioni consultare il catalogo OLOS. - For further information, please consult the catalog OLOS. - Pour tous renseignements complémentaires merci de bien vouloir consulter notre catalogue OLOS. - Weitere Informationen finden Sie in unserem OLOS Katalog. - Более подробная информация представлена в каталоге OLOS.

* Valori medi riferiti agli ultimi due anni di produzione e relativi alla finitura naturale del prodotto - Average values referred to the last two years of production and related to the matt finish of the product - Valeurs moyennes des deux dernières années de production et relatifs à la finition naturelle du produit - Durchschnittswerte, die sich auf die letzten zwei Produktionsjahre beziehen und auf die matte Oberfläche - Средние значения относятся к последним двум годам производства и натуральной отделке поверхности

** Valori relativi alla finitura naturale del prodotto ed a test effettuati da laboratori esterni accreditati, disponibili in azienda; ci rendiamo disponibili alla verifica dell'eventuale lotto interessato all'acquisto. - As far as values relating to the matt finish of the product and to tests carried out by certified external laboratories whose results are available upon request at Headoffice, we are willing to check the lot you are interested in purchasing. - Valeurs se référant à la finition naturelle du produit selon des tests effectués par des laboratoires extérieurs accrédités et à la disposition de toute personne intéressée auprès de nos bureaux; nous sommes disponibles pour le contrôle de l'éventuel lot concerné par l'achat. - Werte bezogen auf das natürliche Produktfinish und in anerkannten externen Labors geprüft, im Unternehmen erhältlich; für eventuelle Prüfungen der zu erwerbenden Warenposten stehen wir gern zur Verfügung. - Значения, касающиеся натуральных характеристик изделий и тестов, выполненных внешними авторизованными лабораториями, имеются компании. Мы готовы выполнить проверку партии товара, которую намереваетесь приобрести.

*** Test effettuati da laboratori esterni accreditati, disponibili in azienda - Tests carried out by certified external laboratories whose results are available upon request at Headoffice - Tests effectués par des laboratoires extérieurs accrédités et à la disposition de toute personne intéressée auprès de nos bureaux. - Werte bezogen in anerkannten externen Labors geprüft, im Unternehmen erhältlich. - Тесты, выполненных внешними авторизованными лабораториями, имеются компании.

● Per prodotti chimici di uso domestico e additivi per piscina. - For domestic chemicals and swimming pool additives. - Pour produits chimiques à usage domestique et additifs pour piscines. - Für chemische Produkte für den Hausgebrauch und Schwimmbadzusätze. - Для бытовых химикатов и добавок для бассейнов.

▲ Valori wet DCOF specifici disponibili in azienda - Wet DCOF specific values available at the company - Valeurs wet DCOF spécifiques disponibles à l'usine - Prüfwerte Wet DCOF stehen im Werk zur Verfügung - Показатели wet DCOF доступны при запросе

CARATTERISTICHE TECNICHE

TILE PERFORMANCE DATA - NOTES TECHNIQUES - TECHNISCHE AUSKÜNFTE - ТЕХНИЧЕСКАЯ ХАРАКТЕРИСТИКА

Classificazione secondo EN ISO 14411 ISO 13006 annesso G gruppo Bla con Ev ≤0,5 % - Classification in accordance with EN ISO 14411 ISO 13006 annex G standards Bla with Ev ≤ 0,5% - Classification selon EN ISO 14411 ISO 13006 annexe G groupe Bla avec Ev ≤0,5% - Klassifizierung gemäß EN ISO 14411 ISO 13006 anlage G Gruppe Bla mit Ev ≤0,5% - Классификация в соответствии с EN ISO 14411 ISO 13006, приложение G, стандарт Bla, где Ev ≤0,5%

| | CARATTERISTICA TECNICA - TECHNICAL CHARACTERISTIC CARACTERISTIQUE TECHNIQUE - TECHNISCHE DATEN ТЕХНИЧЕСКАЯ ХАРАКТЕРИСТИКА | NORMA NORMS NORME NORM HOFMA | VALORE * MEDIO "CAESAR" AVERAGE "CAESAR" VALUE * VALEUR * MOYEN "CAESAR" "CAESAR" DURCHSCHNITTSWERT * СРЕДНЕЕ ЗНАЧЕНИЕ "CAESAR" * | | |
|--|--------------------------------------------------------------------------------------------------------------------------------------------------------------------------------------------------------------------------------------|------------------------------------------|------------------------------------------------------------------------------------------------------------------------------------------------------------------------------|----------------------------------------------------------------------------------------------------------------------------------------------------------------------------------------------------------------------------------------------------------------------------------------------------------------------------------------------------------------------------------------------------------------------------------------------------------------------------------|-------------------------------------------------------------------------------------|
| | | | ANIMA - ANIMA EVER ANIMA FUTURA | ANIMA - ANIMA EVER | ALCHEMY - JOIN - PORTRAITS PRIMA - RELATE FLAME SHAPES OF ITALY - TINTE UNITE |
| | | | Lucidato | Silk | Matt |
| | Dimensione - Size Dimension - Abmessungen - Размер | ISO 10545-2 | Conforme - In accordance Conforme - Erfüllt - Соответствует | Conforme - In accordance Conforme - Erfüllt - Соответствует | Conforme - In accordance Conforme - Erfüllt - Соответствует |
| | Assorbimento d'acqua* - Water absorption* Absorption d'eau* - Wasseraufnahme* - % Поглощения воды* | ISO 10545-3 | ≤ 0,1% | ≤ 0,1% | ≤ 0,1% |
| | Resistenza alla flessione* - Bending strength* Résistance à la flexion* - Biegezugfestigkeit* - Упругость* | ISO 10545-4 | Conforme - In accordance Conforme - Erfüllt - Соответствует | Conforme - In accordance Conforme - Erfüllt - Соответствует | Conforme - In accordance Conforme - Erfüllt - Соответствует |
| | Resistenza all'urto - Impact resistance Résistance au choc - Schlagfestigkeit - Ударопрочность | ISO 10545-5 | ≥ 0,80 | ≥ 0,80 | ≥ 0,80 |
| | Resistenza all'abrasione profonda* - Deep scratch resistance* Résistance à l'abrasion profonde* - Widerstand gegen Tiefenverschleiß* Устойчивость глубокому истиранию* | ISO 10545-6 | - | Conforme - In accordance Conforme - Erfüllt - Соответствует | Conforme - In accordance Conforme - Erfüllt - Соответствует |
| | Coefficiente di dilatazione termica lineare* - Thermal linear expansion coefficient* Coefficient de dilatation thermique linéaire* - Koeffizient der linearen thermischen Dehnung* Кoeffициент линейного теплового расширения* | ISO 10545-8 | ≈ 7 (10 ⁻⁶ °C ⁻¹) | ≈ 7 (10 ⁻⁶ °C ⁻¹) | ≈ 7 (10 ⁻⁶ °C ⁻¹) |
| | Resistenza al cavillo - Cracking resistance Résistance aux craquelures - Haarriß-Beständigkeit Устойчивость эмали к краquelору | ISO 10545-11 | Conforme - In accordance Conforme - Erfüllt - Соответствует | - | - |
| | Resistenza all'attacco chimico ● - Resistance to chemical attack ● Résistance à l'attaque chimique ● - Beständigkeit gegen Chemikalien ● Устойчивость к химическому воздействию ● | ISO 10545-13 | Resistente - Resistant Résistante - Beständig - Стойкий | Resistente - Resistant Résistante - Beständig - Стойкий | Resistente - Resistant Résistante - Beständig - Стойкий |
| | Resistenza alle macchie* - Resistance to stains* Résistance aux taches* - Fleckenbeständigkeit * Устойчивость к образованию пятен* | ISO 10545-14 | Pulibile - Cleanable Nettoyable - Leicht zu reinigen - Чистящийся | Pulibile - Cleanable Nettoyable - Leicht zu reinigen - Чистящийся | Pulibile - Cleanable Nettoyable - Leicht zu reinigen - Чистящийся |
| | Resistenza allo scivolamento** - Slip resistance** Résistance au glissement** - Rutschhemmende Eigenschaft** Сопротивление скольжению** | DIN 51130 DIN 51097 | - | - | R9 Matt |
| | | ▲ ANSI A326.3 | - | - | Wet DCOF ≥ 0,42 |
| | Resistenza all'abrasione superficiale - Surface abrasion resistance Résistance à l'abrasion superficielle - Widerstand gegen Oberflächenverschleiß Сопротивление на изгиб и усилию на излом | EN ISO 10545-7 | Test disponibili in azienda Tests available at our company Tests disponibles en usine Prüfzeugnisse beim Werk erhältlich Протоколы испытаний хранятся в компании | - | - |
| | Spessore nominale - Nominal Thickness Épaisseur nominale - Nominalstärke Номинальная толщина | | 6 mm 160x320 - 120x278 | 6 mm 160x320 - 120x278 | 6 mm 160x320 - 120x278 12 mm 162x324 |
| | Resistenza dei colori alla luce - Resistance of colours to light Résistance des couleurs a la lumière - Lichtechtheit der Farben Светостойкость цветов | DIN 51094 | | Resistente - Resistant Résistante - Beständig - Стойкий | |
| | Reazione al fuoco - Reaction to fire Réaction au feu - Brandverhalten Огнестойкость | Decisione europea 96/603/EC | | Classe A1 _{fl} | |
| | Cessione piombo e cadmio* - Release of lead and cadmium* Cession de plomb et de cadmium* - Freisetzung von Blei und Cadmium* Выделение свинца и кадмия* | ISO 10545-15 | | 0 mg/dm ² | |
| | Emissione VOC* - Hygienic properties* Propriétés hygiéniques* - Hygienische Eigenschaften* Выделение ЛОС* | UNI EN 16000-9 | | Classe A+ (regolamentazione francese) - Class A+ (French regulation) Classe A+ (réglementation française) - Klasse A+ (französische Richtlinie) Класс А+ (французские правила) | |
| | Proprietà igieniche* - VOC emission* Rejet de COV* - Freisetzung von VOC* Гигиеническая характеристика* | Metodo Interno | | Grado di rimozione dei batteri >99% dopo pulizia con normale detergente battericida Bacteria elimination >99% after cleaning with a standard bactericidal detergent Degré d'élimination des bactéries >99% après nettoyage à l'aide d'un détergent bactéricide standard Grad der Bakterienentfernung >99 % nach der Reinigung mit normalem, bakterizidem Reinigungsmittel) Степень уничтожения бактерий >99% после чистки обычным антибактериальным моющим средством | |
| | Resistenza al calore secco*** - Resistance to dry-heat*** Résistance à la chaleur sèche*** - Beständigkeit gegen trockene Wärme*** Стойкость к сухому теплу*** | EN 12722 EN 438-2 par.16 | | Classe A - Class A Classe A - Klasse A Класс А | |
| | Resistenza al calore umido*** - Resistance to wet-heat*** Résistance à la chaleur humide*** - Beständigkeit gegen feuchte Wärme*** Стойкость к влажному теплу*** | UNI EN 12721:2013 | | Classe A - Class A Classe A - Klasse A Класс А | |
| | Resistenza ai liquidi freddi*** - Resistance to cold liquid*** Résistance aux liquides froids*** - Beständigkeit gegen kalte Flüssigkeiten*** Стойкость к холодным жидкостям*** | EN 12720 | | Classe A - Class A Classe A - Klasse A Класс А | |
| | Tendenza a ritenere lo sporco*** - Tends to withhold dirt*** Tendance à retenir la saleté*** - Schmutzanfälligkeit*** Склонность к задерживанию грязи*** | UNI 9300:2015 | | Nessun cambiamento visibile - No visible change Aucun changement visible - Keine sichtbare Veränderung Отсутствие видимых изменений | |

Le tonalità dei campioni sono da considerarsi puramente indicative. - Tones of samples are indicative. - Les tonalités des échantillons sont purement indicatives. Die farbtöne der Muster sind als rein indicativ zu betrachten. - Тона образцов ориентировочные.

Caesartech Solutions



Caesartech

Solutions

La divisione CaesarTech di Ceramiche Caesar offre ai progettisti, alle imprese e ai rivenditori un servizio qualificato di consulenza sulle soluzioni tecniche ed estetiche che oggi ampliano le possibilità di utilizzo del grès porcellanato.

Nelle pagine seguenti si illustrano tutte le soluzioni applicative che la divisione mette a disposizione nei seguenti ambiti progettuali: personalizzazioni, soluzioni per piscine e ambienti wellness, pavimenti autoposanti e sopraelevati, facciate ventilate e percorsi tattili. In tutte le tipologie di ambiente, sia indoor sia outdoor, grazie alla disponibilità di un'ampia e profonda gamma di formati, spessori, pezzi speciali ed elementi ad hoc progettati e realizzati su misura, prodotto e soluzione non sono più due identità separate, ma diventano un fondamentale unicum progettuale.

The CaesarTech Division of Ceramiche Caesar offers project managers, building companies and retailers a qualified consulting service on the technical and aesthetic solutions that extend the possibilities of use for porcelain stoneware today.

The following pages illustrate the solutions that the Division offers for the following contexts: customization, solutions for swimming pools and wellness spaces, installation without adhesives and raised floors, ventilated walls and tactile pathways. In any kind of environment, indoor and outdoor, the vast range of sizes, thickness options, trim pieces and custom-made elements make 'product' and 'solution' a single entity instead of two separate identities.

La divisione CaesarTech de Ceramiche Caesar propose aux architectes, entreprises et distributeurs des conseils qualifiés au sujet des solutions techniques et esthétiques qui élargissent aujourd'hui les possibilités d'utilisation du grès cérame.

Les pages suivantes présentent toutes les solutions pratiques que propose la Division dans les domaines suivants : personnalisations, solutions pour piscines et spas, sols auto-posants et sur plots, façades ventilées et parcours tactiles. Qu'il s'agisse d'un espace intérieur ou extérieur - grâce à la large gamme de formats, d'épaisseurs, de pièces spéciales et d'éléments conçus et réalisés sur mesure - produit et solution ne sont plus deux choses distinctes mais forment un tout conceptuel indissociable.

Der Geschäftsbereich CaesarTech von Ceramiche Caesar bietet Planern, Unternehmen und Händlern qualifizierte Beratung über die technischen und optischen Lösungen, die heute die Anwendungsbereiche des Feinsteinzeugs erweitern.

Auf den nachstehenden Seiten werden alle Lösungen erläutert, die der Geschäftsbereich für folgende Planungsaufgaben zur Verfügung stellt: Personalisierung, Lösungen für Swimming-Pools und Wellness-Bereiche, selbstfixierende und Doppelböden, hinterlüftete Fassaden und taktile Leitsysteme. Für jede Umgebung, innen wie außen, verschmelzen Produkt und Lösung dank der umfassenden und in die Tiefe gehenden Palette aus Formaten, Stärken, Formstücken und nach Maß gefertigten Elementen zu einem einzigen und einzigartigen Projekt.

Подразделение CaesarTech от Ceramiche Caesar предлагает дизайнерам, компаниям и дистрибьюторам квалифицированные консультационные услуги по техническим и эстетическим решениям, которые теперь расширяют возможности применения керамогранита.

На последующих страницах проиллюстрированы все прикладные решения, которые это подразделение предоставляет в распоряжение в следующих сферах проектирования: персонализация, решения для бассейнов и зон велнеса, самоукладывающиеся и фальшполы, вентилируемые фасады и маршруты для слабовидящих. Благодаря наличию большого и разнообразного ассортимента форматов, толщины, специальных изделий и элементов на заказ, спроектированных и изготовленных по предоставленным размерам, в пространствах любого типа, как внутренних, так и наружных, изделие и решение больше не являются разными вещами, а превращаются в фундаментально важную единую составляющую проектирования.



The perfect solution for working environments



In uffici, centri direzionali, banche, e centri di elaborazione dati si verifica un continuo incremento e aggiornamento delle dotazioni tecnologiche ed impiantistiche. Per tali destinazioni d'uso Caesar consiglia il ricorso a pavimenti sopraelevati, nei quali il piano di calpestio, composto da pannelli facilmente rimovibili, risulta sollevato dal massetto.

Offices, banks, and data processing centers need constant enhancement and updating of technological equipment. To facilitate such instances, Caesar recommends using raised floors consisting of panels that can be easily removed because they are elevated from the footing of the floor.

Les bureaux, les centres d'affaire, les banques et les centres de traitement des données s'équipent régulièrement de nouvelles technologies et d'installations qu'il faut entretenir. Pour ces destinations d'emploi, Caesar vous conseille d'utiliser des sols surélevés dont le plancher, composé de panneaux facilement amovibles.

In Büros, Verwaltungen, Banken und Datenverarbeitungszentren ist eine ständige Zunahme und Aktualisierung der technischen und der anlagentechnischen Ausstattungen festzustellen. Für diese Anwendungsbereiche empfiehlt Caesar die Verwendung von Doppelböden, deren Trittläche aus leicht entfernbarer Platten besteht und vom Estrich "abgehoben" ist.

В офисах, бизнес-центрах, банках, центрах обработки данных постоянно возникает необходимость в обновлении аппаратного обеспечения или модернизации, перестановке различного инженерного оборудования и коммуникаций. В таких контекстах Caesar рекомендует устанавливать фальшполы – сборную конструкцию, в которой напольное покрытие, состоящее из легко снимаемых панелей, приподнято над черновым полом.



Info
Resources
Tools

Vantaggi

Advantages

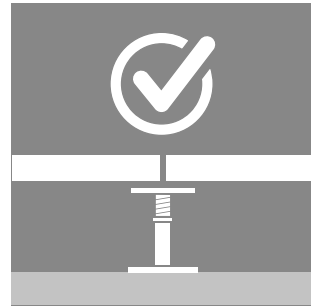

Installazione rapida e pulita, senza collanti
 Rapid and clean installation, without adhesives
 Installation rapide et propre, sans colle
 Schnelle und saubere installation ohne kleber
 Быстрая и простая укладка без клея

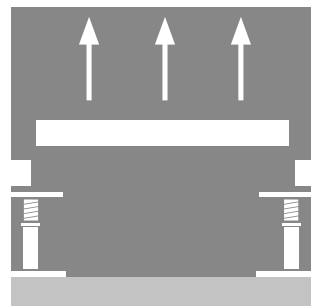

Rapida rimozione
 Rapid removal
 Élimination rapide
 Schnelle entfernung
 Быстрый демонтаж

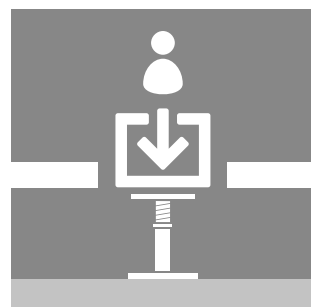

Accessibilità
 Easy access
 Accès facile
 Gute zugänglichkeit
 Легкий доступ

Grès porcellanato di alta qualità
 High quality porcelain stoneware
 Grès cérame de haute qualité
 Qualitativ hochwertiges Feinsteinzeug
 Высококачественный керамогранит

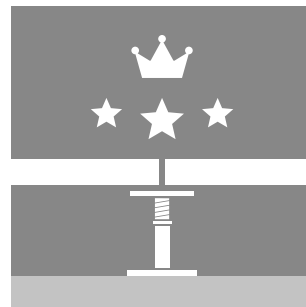

Altezza regolabile
 Adjustable height
 Hauteur réglable
 Verstellbare höhe
 Регулировка по высоте

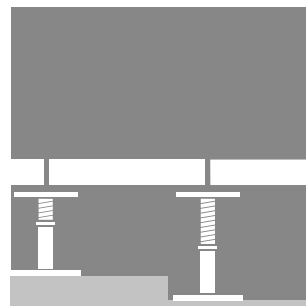

Restyling senza smantellare
 Renovate without demolishing
 Restylage sans travaux d'aménagement
 Restyling ohne demolition
 Переоформление пола без разрушения существующего материала

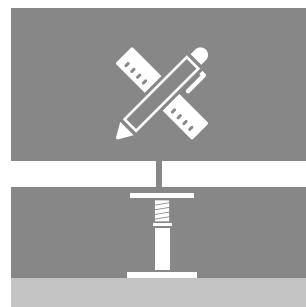

Componenti del sistema

Elements of the system

Moduli sopraelevati

Raised Modules - Modules Surélevés - Doppelbodenmodule - Модульные Фальшполы



Pannello sopraelevato

Upper surface layer - Revêtement supérieur - Oberbelag - Верхнее покрытие

1 RIVESTIMENTO CERAMICO SUPERIORE
 Upper ceramic cladding - Revêtement céramique supérieur - Keramik-Oberbelag - Верхнее керамическое покрытие

2 ANIMA DI SUPPORTO: SOLFATO O TRUCIOLARE
 Structural core: sulphate or chipboard - Armature: sulfate ou particules
 Trägerplatte: Calciumsulfat oder Spanholz - Промежуточная панель: сульфат кальция или Дсп

3 RIVESTIMENTO INFERIORE
 Lower surface layer - Revêtement inférieur - Unterbelag - Покрытие

4 BORDO PERIMETRALE
 Perimetral border - Cadre - Kantenschutz - Периметральная окантовка

Sottostruttura

Substrate - Châssis - Unterstruktur - Опорных

5 COLONNE REGOLABILI
 Base - Colonne - Stützen - Стойки

6 TRAVERSE
 Crosspieces - Traverses - Querbalken - Стрингеры

7 GUARNIZIONI
 Gaskets - Joints - Dichtungen - Накладки

8 PANNETTO FONOASSORBENTE
 Sound-absorbing cloth - Panneau absorbant acoustique - Schalldämpfendes Gewebe - Звукоизоляционный мат

Componenti del sistema

Elements of the system

Anima di supporto in solfato

Structural core: sulphate - Armature: sulfate - Trägerplatte: Calciumsulfat - Промежуточная панель: сульфат кальция

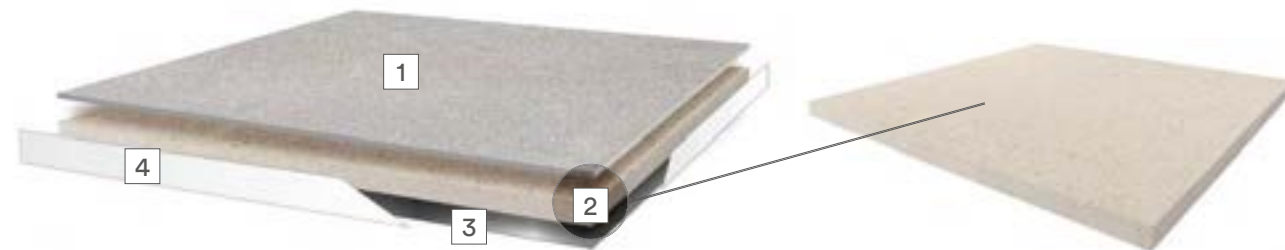

1 RIVESTIMENTO CERAMICO SUPERIORE
Upper ceramic cladding - Revêtement céramique supérieur
Keramik-Oberbelag - Верхнее керамическое покрытие

2 ANIMA DI SUPPORTO: PANNELLO A BASE DI SOLFATO DI CALCIO
Structural core: Sulphate-based board - Armature: Panneau en sulfate de calcium
Trägerplatte : Calciumsulfat-Platte - Промежуточная панель: Кальциево-сульфатная панель

3 RIVESTIMENTO INFERIORE
Lower surface layer - Revêtement inférieur - Unterbelag - Покрытие

4 BORDO PERIMETRALE
Perimetral border - Cadre - Kantenschutz - Периметральная окантовка

Anima di supporto in truciolare

Structural core: chipboard - Armature: particules - Trägerplatte: Spanholz - Промежуточная панель: дсп

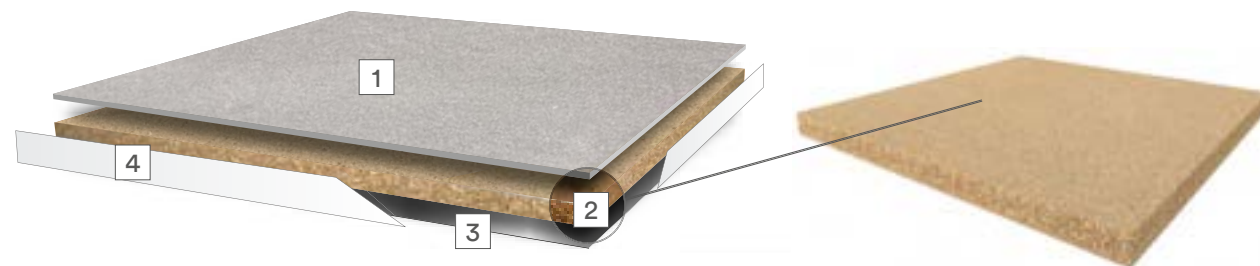

1 RIVESTIMENTO CERAMICO SUPERIORE
Upper ceramic cladding - Revêtement céramique supérieur
Keramik-Oberbelag - Верхнее керамическое покрытие

2 ANIMA DI SUPPORTO: PANNELLO A BASE DI TRUCIOLARE IN LEGNO
Structural core: Particle board made up of wood-chips - Armature: Panneau de particules de bois
Trägerplatte : Spanholzplatte - Промежуточная панель: панель дсп

3 RIVESTIMENTO INFERIORE
Lower surface layer - Revêtement inférieur - Unterbelag - Покрытие

4 BORDO PERIMETRALE
Perimetral border - Cadre - Kantenschutz - Периметральная окантовка

Moduli sopraelevati

Raised modules

Modulo sopraelevato nudo con Æexacta

Bare raised module with Æexacta - Module surélevé nu avec Æexacta - Doppelbodenmodul mit Æexacta - Модульный фальшпол без плитки для Æexacta

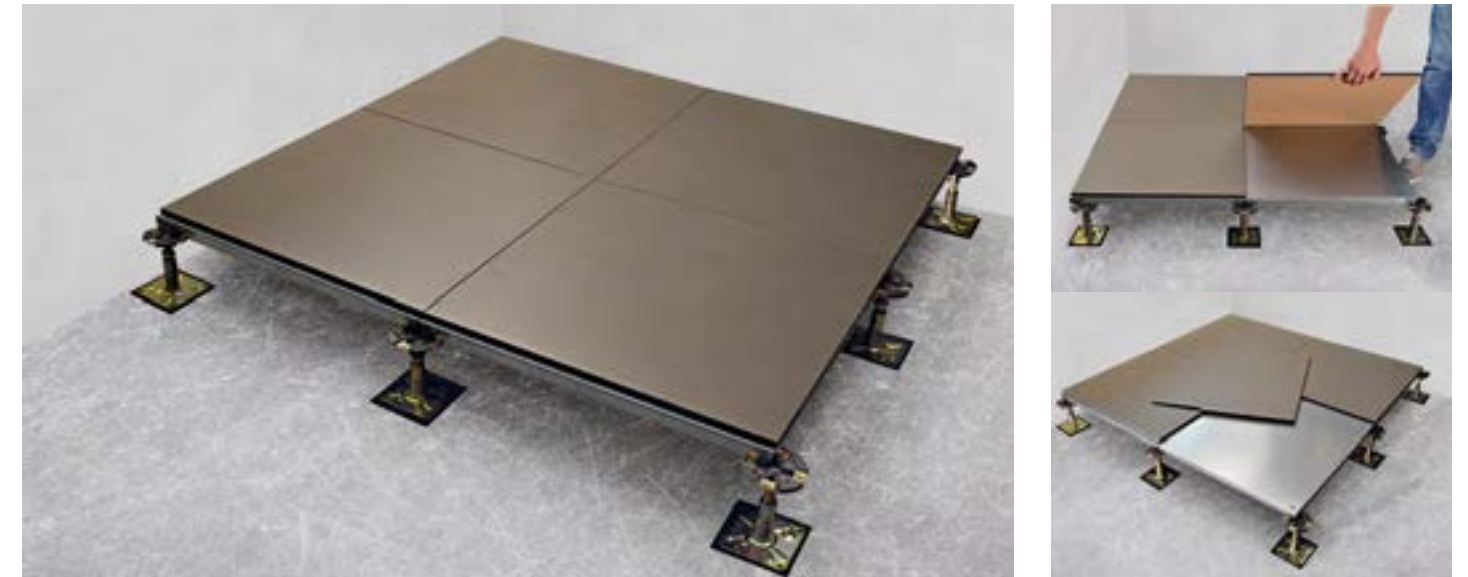

Moduli sopraelevati outdoor con Aextra20

Aextra20 raised modules for outdoor installation - Modules surélevés d'extérieur outdoor con Aextra20
Doppelböden im Freien mit Aextra20 - Модульный фальшпол для экстерьеров с Aextra20



SUPPORTI COMPONIBILI

Modular support - Plot Modulaire - Modularer Träger - Модульная Опора



Il supporto Componibile è un sistema dall'ingombro ridotto, regolabile e componibile, che consente una sopraelevazione da 8 a 30 mm.
The Modular Support is a support with a compact size. It is modular and adjustable to obtain a height ranging from 8 to 30 mm.
Le Support Modulaire est un système à encombrement réduit, réglable et modulaire, qui permet une surélévation de 8 à 30 mm.
Das Trägermodul ist ein platzsparendes, höhenverstellbares und zusammensteckbares System für eine Bodenaufstockung von 8 bis 30 mm.
Составная Опора представляет собой компактную, регулирующую и модульную систему, позволяющую создавать фальшполы высотой от 8 до 30 мм.

SUPPORTI FISSI

Fix supports - Supports fixes - Fixe Träger - Иксированные опоры



Struttura costituita da dischi di spessore variabile che consentono la posa delle lastre a un'altezza di 12, 15 o 20 mm.
Structure made up of disks of variable thickness that allow for the installation of slabs at a raise of 12, 15 or 20mm.
Structure constituée de disques d'épaisseur variable qui permettent de poser les dalles à une hauteur de 12, 15 ou 20 mm.
Eine Struktur, die eine Verlegung der Feinsteinzeugplatten in unterschiedlichen Höhen ermöglicht: 12, 15 oder 20 mm.
Конструкция состоит из дисков различной толщины, которые позволяют установить плитки на высоту 12, 15 или 20 мм.

SUPPORTI REGOLABILI

Adjustable supports - Supports réglables - Verstellbare Träger - Регулируемые опоры



Struttura regolabile in altezza, costituita da una base di appoggio alla soletta e una testa con sistema di autoregolazione dell'inclinazione fino a 5° di pendenza.
Structure with adjustable height made up of a support base to the concrete slab and a head with self-adjusting inclination up to 5°.
Structure réglable en hauteur, constituée d'une base d'appui à la dalle porteuse et d'une tête pourvue d'un système de réglage automatique de l'inclinaison jusqu'à 5°.
Höhenverstellbare Struktur aus einer auf dem Untergrund aufgesetzten Basis und einem Kopf mit Selbstregulierung der Neigung bis zu 5°.
Конструкция состоит из основания и головки с системой саморегулирования, которая в состоянии компенсировать уклон до 5°.

SUPPORTI AUTOLIVELLANTI

Self-levelling supports - Supports auto-nivelants - Selbstnivellierende Träger - Саморегулирующиеся опоры



Struttura regolabile in altezza costituita da una base di appoggio alla soletta e una testa con sistema di autoregolazione dell'inclinazione fino a 5° di pendenza.
Structure with adjustable height made up of a support base to the concrete slab and a head with self-adjusting inclination up to 5°.
Structure réglable en hauteur constituée d'une base d'appui à la dalle porteuse et d'une tête pourvue d'un système de réglage automatique de l'inclinaison jusqu'à 5°.
Höhenverstellbare Struktur aus einer auf dem Untergrund aufgesetzten Basis und einem Kopf mit Selbstregulierung der Neigung bis zu 5°.
Конструкция состоит из основания и головки с системой саморегулирования, которая в состоянии компенсировать уклон до 5°.

Temporary floors



Æxacta è un sistema di pavimentazione autoposante, che si installa senza colle o stucchi, abbattendo tempi e costi. Indicato per destinazioni provvisorie e dove è necessario preservare la pavimentazione preesistente.

Æxacta is a system of loose laid floors that can be installed without adhesive or mortar which saves time and reduces costs. It is recommended for temporary installations where it is necessary to preserve the existing floor.

Le système de sol auto-posant Æxacta s'installe sans colle ni mortier, soit un gain important en termes de temps et de coût. Destiné à des installations temporaires, il permet également de préserver le revêtement de sol existant.

Æxacta ist ein selbstfixierendes Bodensystem, das ohne Kleber und Fugenmassen verlegt wird und damit Zeit und Kosten optimiert. Es eignet sich für temporäre Strukturen und überall dort, wo vorhandene Bodenbeläge erhalten bleiben sollen.

Æxacta – это система напольных плиточных покрытий, укладка которой выполняется без применения клеев и затирок с вытекающей из этого экономией времени и затрат.



Info
Resources
Tools

Vantaggi

Advantages



Installazione semplice e pulita
Simple and clean installation
Installation simple et propre
Saubere und einfache Installation
Простая и чистая укладка



Rapida pulizia
Easy to clean
Nettoyage rapide
Schnell zu reinigen
Простая чистка

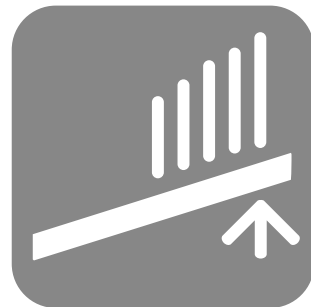

Veloce da rimuovere
Quick removal
Facile et rapide à éliminer
Schnell zu entfernen
Легко демонтируется



Calpestabile da subito
The floor can be used immediately
Immédiatement praticable
Sofort begehbar
Немедленная эксплуатация пола



Facile manutenzione
Easy maintenance
Entretien facile
Pflegeleicht
Простой уход



Migliora l'isolamento acustico
Improved acoustic insulation
Isolation acoustique accrue
Verbesserte Schalldämmung
Повышает звукоизоляцию

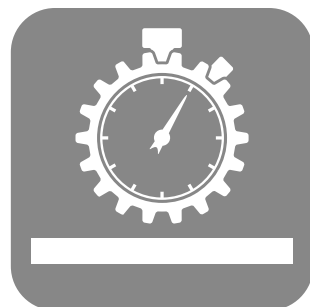

Interventi veloci ed economici
Fast and money-saving work
Interventions rapides et économiques
Schnelles und kostengünstiges Arbeiten
Быстрые и недорогие работы

Componenti del sistema

Elements of the system

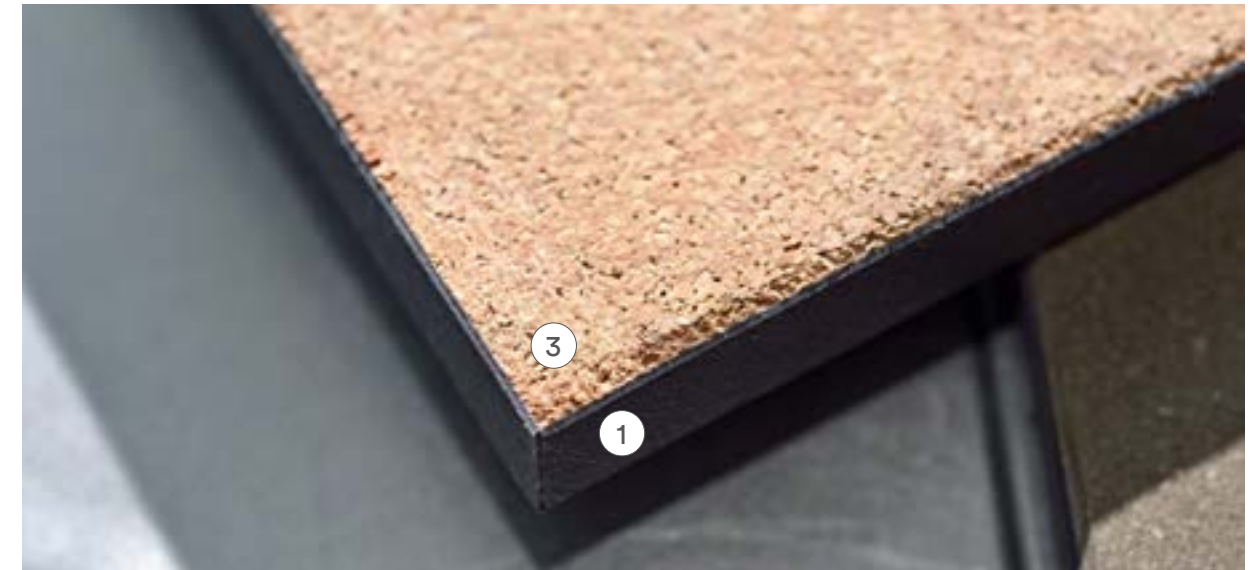

1 - BORDATURA PERIMETRALE

Perimetral border - Cadre - Umlaufender Kanteschutz - Периметральная планка

2 - LASTRA IN GRÈS PORCELLANATO

Porcelain stoneware slab - Dalle en grès cérame - Platte in Feinsteinzeug - Керамогранитная плита

3 - RIVESTIMENTO INFERIORE IN SUGHERO

Lower cork layer - Revêtement inférieur - Unterbelag - Нижняя панель

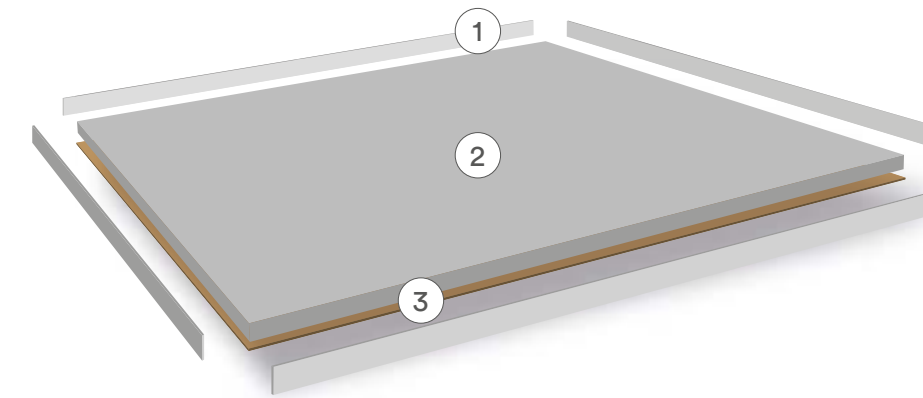

La bordatura perimetrale in PVC delle lastre Æxacta può essere realizzata in più colori, come riportato nella tabella sottostante:

The PVC perimetral border of Æxacta slabs is available in different colours as reported in the chart below:

Le cadre en PVC des dalles Æxacta peut être réalisé dans plusieurs couleurs comme indiqué dans les schémas ci-dessous:

Die PVC Kanten der Æxacta Platten sind in den nachfolgenden Farben erhältlich:

Периметральные планки из ПВХ для плиток Æxacta могут быть разных цветов, как указано в таблице ниже:

| Bordo - Edge - Bord - Ränder - Кромка | Colori - Colors - Couleurs - Farben - Цветах |
|---------------------------------------------------------------------------------|----------------------------------------------|
| Avorio - Ivory - Ivoire - Elfenbein - Слоновая кость | |
| Beige - Beige - Beige - Beige - Бежевый | |
| Grigio Chiaro - Light Grey - Gris Clair - Hellgrau - Светло-серый | |
| Grigio Antracite - Anthracite - Anthracite - Anthrazitgrau - Серый антрацитовый | |
| Nero - Black - Noir - Schwarz - Черный | |

Formati

Sizes

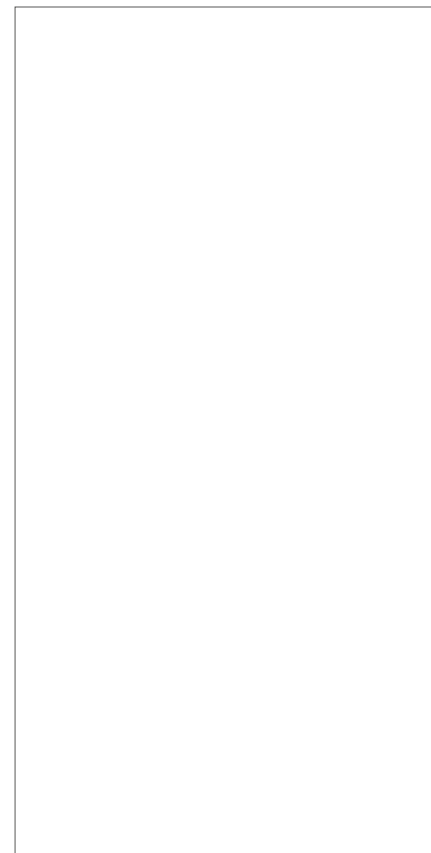

160x320
63¹/₈"x126"



120x278
47²/₈"x109⁷/₁₆"



120x120
47²/₈"x47²/₈"



60x120
23⁵/₈"x47²/₈"



80x160
31¹/₈"x63"



30x120
11³/₁₆"x47²/₈"



20x120
7⁷/₈"x47²/₈"



40x80
15⁵/₈"x31¹/₈"



80x80
31¹/₈"x31¹/₈"



60x60
23⁵/₈"x23⁵/₈"

Moduli sopraelevati in acciaio e Æxacta, una soluzione semplice e pratica. - Steel raised modules and Æxacta, an easy and functional solution. - Des modules surélevés en acier et Æxacta, une solution simple et pratique. - Die Doppelbodenmodule aus Stahl und Æxacta, eine einfache und zweckmäßige Lösung. - Стальные фальшполы и Æxacta, простое и практичное решение.

Il sistema per pavimento sopraelevato con pannelli in acciaio, da completare con una finitura autoposante, consente a chi comprerà o affitterà il locale di rinnovare il pavimento esistente o di completare il pavimento sopraelevato nudo con la finitura che preferisce. Anche in questo campo applicativo Aexacta si rivela una soluzione ideale, in quanto è rimovibile e sostituibile in qualsiasi momento, fornendo inoltre la garanzia di tutte le innegabili qualità prestazionali e il superiore livello estetico del grès porcellanato Caesar.

The steel raised floor system to complete with a self-fixing finish will allow users buying or renting a venue to renovate the existing floor or cover the raised floor with the desired surface finish. Even in this field of application, Aexacta is the perfect solution as it can be removed and replaced at any time while at the same time guaranteeing the top quality performance and aesthetic of Caesar porcelain stoneware.

Le système pour planchers surélevés en acier, qui se complète d'une finition à fixation rapide, permet au bailleur ou locataire du bien immobilier de rénover son plancher existant ou de parachever son plancher surélevé nu avec la finition qu'il préfère. Dans ce type d'application, Aexacta s'avère être également une solution idéale car le système est amovible et remplaçable à tout moment, et garantit en plus toutes les prestations inégalables et la qualité esthétique supérieure du grès cérame Caesar.

Das Doppelbodensystem aus Stahltafeln wird mit einem selbstfixierenden Belag komplettiert und erlaubt dem Mieter oder Käufer des Raums, den vorhandene Boden zu renovieren oder die bloße Doppelbodenstruktur mit dem Belag seiner Wahl fertigzustellen. Auch in diesem Fall erweist sich Aexacta als ideale Lösung, denn Entfernung und Austausch sind jederzeit möglich. Und das mit der Garantie aller Leistungsmerkmale und der gelungenen Optik des Feinsteinzeugs von Caesar.

Система для фальшполов со стальными панелями позволяет тем, кто покупает или арендует офис или любые другие помещения, обновить существующий пол или подобрать верхнее покрытие позже, чем была установлена сама базовая конструкция фальшпола. И в этом случае Аехаста представляется идеальным решением, поскольку плитки легко снимаются и заменяются в любой момент, а кроме того, обеспечивают все те высокие эксплуатационные и эстетические качества, которые отличают керамогранит Caesar.

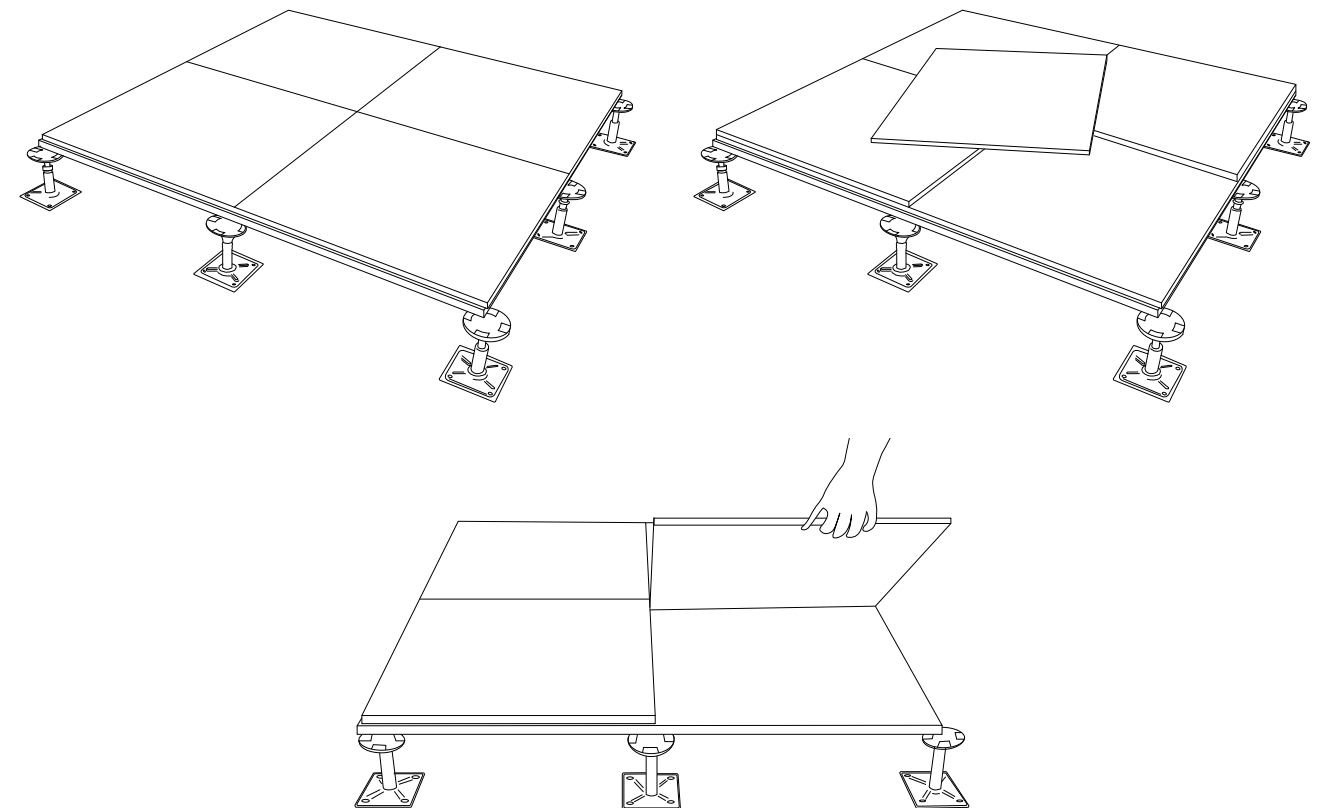

Per maggiori informazioni consultare il catalogo Æxacta e il nostro sito www.caesar.it/caesartech. - For further information, please consult the catalog Æxacta and our CaesarTech website www.caesar.it/caesartech. - Pour tous renseignements complémentaires merci de bien vouloir consulter notre catalogue Æxacta et notre site internet www.caesar.it/caesartech. - Weitere Informationen finden Sie in unserem Æxacta Katalog und auf unsere Website www.caesar.it/caesartech. - Более подробная информация представлена в каталоге Æxacta и на нашем сайте www.caesar.it/caesartech.

Finitura superiore*

Top surface finish* - Finition Supérieure* - Oberbelag* - Верхняя Часть*

| | |
|-----------------------------------------------------------------------------------------------------------------------------------------------------------------------------------------------------------------------------------------------------------------------------------------|---------------------------------------------------------------------------------------|
| Materiale - Material Matériau - Material - Материал | Grès porcellanato - Porcelain stoneware Grès cérame - Feinsteinzeug - Керамогранит |
| Spessore - Thickness Épaisseur - Stärke - Толщина | 10-10,5 mm |
| Densità - Density Densité - Dichte - Плотность | 2200 kg/m ³ |
| Variazione dimensionale (dopo 24 h di immersione in acqua) - Dimensional tolerances (after 24 hours immersed in water) Dilatation (après 24h d'immersion dans l'eau) grössenabweichung (nach 24 h eintauchen in wasser) - Изменение размеров (через 24 часа после погружения в воду) | 0% |

* Vedi tabella tecnica a pagina 439. - See technical chart on page 439. - Faire référence au tableau technique à la page 439. - Siehe technische Tabelle auf der Seite 439. - См. техническую таблицу на странице 439.

Finitura inferiore

Lower surface finish - Finition Inférieure - Unterbelag - Нижняя Часть

| | |
|-----------------------------------------------------------------------------------------------------------------------------------------------------------|---------------------------------------------------------------------------------------|
| Materiale - Material Matériau - Material - Материал | Sughero - Cork Liège - Kork - Пробка |
| Spessore - Thickness Épaisseur - Stärke - Толщина | 2 mm |
| Densità - Density Densité - Dichte - Плотность | 190 kg/m ³ |
| Resistenza alla compressione - Compressive strength Résistance à la compression - Stauchhärte - Прочность при сжатии | < 35% |
| Recupero alla compressione - Compressive strength recovery Récupération après compression - Druckfestigkeitsvermögen - Восстановление при сжатии | > 75% |
| Tensione di rottura - Breakage Load Tension De Rupture - Bruchlast - Разрушающее Напряжение | > 400 kPa |
| Contenuto di umidità - Moisture level Contenu d'humidité - Feuchtigkeitsgehalt - Содержание влаги | > 8% |
| Resistenza all'acqua bollente - Resistance to boiling water Résistance à l'eau bouillante - Widerstand bei kochendem wasser - Стойкость в кипящей воде | Non si degrada - Non-degradable Ne se dégrade pas - Nichtabbaubar - Не распадается |
| Conducibilità termica - Thermal conduction Conductibilité thermique - Wärmeleitfähigkeit - Теплопроводность | 0,06 W (m.K) |
| Riduzione acustica all'impatto - Acoustic reduction Réduction acoustique à l'impact - Schallschutz - Изоляция ударного шума | 18 dB |
| Resistenza termica - Thermal resistance Résistance Thermique - Wärmewiderstand - Тепловое Сопротивление | 0,033 m ² K/w |

Caratteristiche tecniche della lastra Æxacta (gres porcellanato + sughero)

Technical features of the Æxacta slab (porcelain stoneware + cork) - Caractéristiques techniques de la dalle Æxacta (grès cérame + liège) - Technische Eigenschaften der Æxacta Platte (Feinsteinzeug + Kork) - Общие технические характеристики плит (керамогранит + пробка)

| | | |
|--------------------------------------------------------------------------------------------------------------------------------|---------------------------------------|----------------------------------------------|
| Caratteristica tecnica - Technical characteristic Caractéristique technique - Technische daten - Техническая характеристика | Norma - Norms Norme - Norm - Норма | Valore - Value Valeur - Wert - Показатель |
| Reazione al fuoco - Reaction to fire Réaction au feu - Brandverhalten - Пожаробезопасность | UNI EN 13501-1: 2009 | B _{fl} - s1 |
| Classificazione Voc - VOC classification Classification VOC - VOC Klassifizierung - Классификация по выделению ЛОС | DEVL1104875A | A+ |

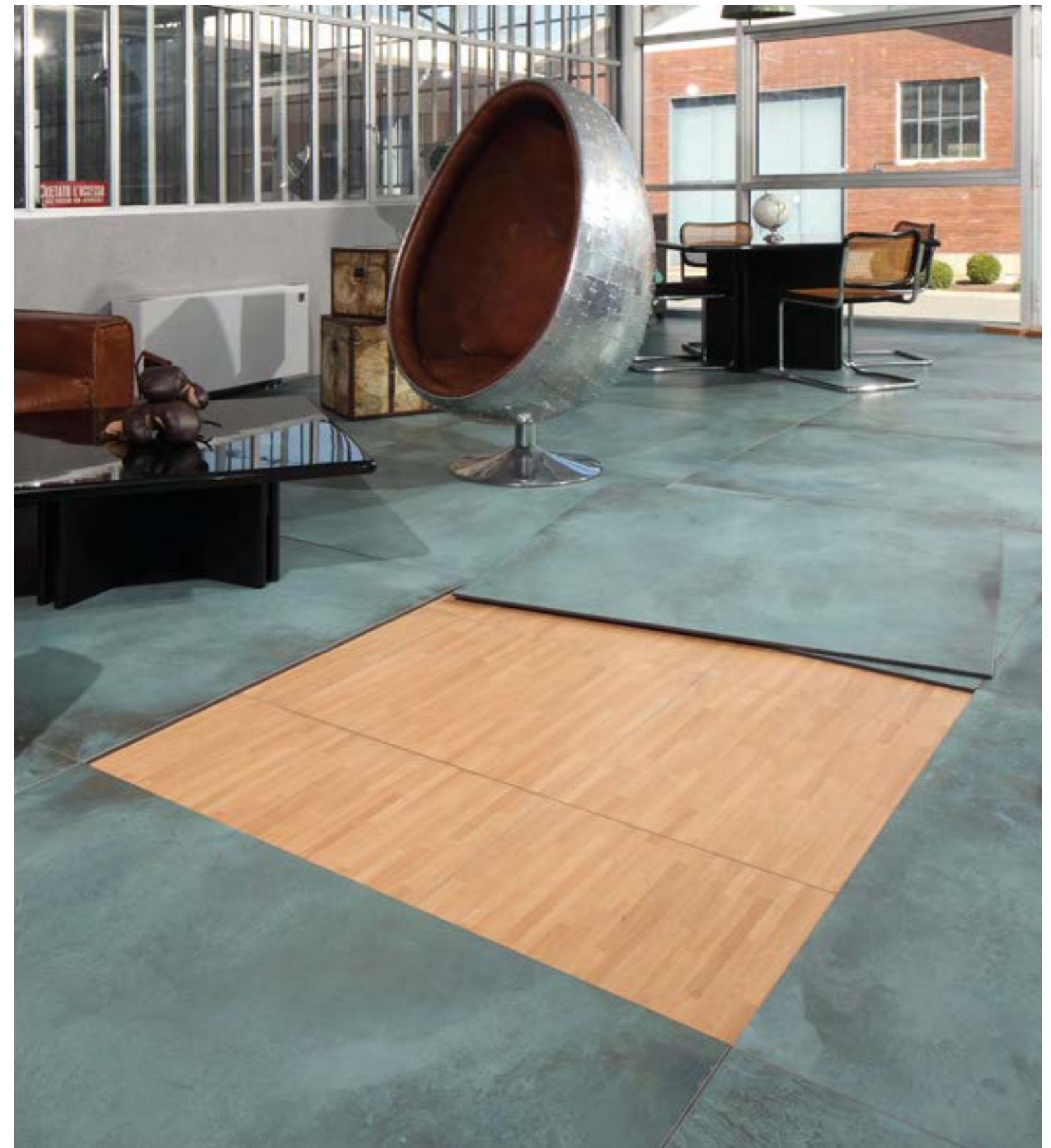

Aquae

Generating wellness



La linea Aquae nasce per soddisfare tutte le necessità progettuali negli spazi come piscine, docce e aree benessere. Vantando una ricca scelta di look, materiali e pezzi speciali, Aquae assicura la massima continuità architettonica in qualsiasi contesto e ottimi risultati in termini di tenuta antiscivolo, resistenza e igiene.

The Aquae line has been designed to fulfill all the needs of spaces, such as swimming pools, showers and wellness areas. With its broad assortment of looks, materials and trim pieces, Aquae ensures the maximum architectural continuity in any context, as well as excellent results in terms of non-slip properties, resistance and hygiene.

La ligne Aquae a été créée spécialement pour répondre à la conception de piscines, douches et spas. Grâce à une large palette de motifs, de matériaux et de pièces spéciales, Aquae assure une parfaite continuité architecturale doublée d'excellentes performances anti-dérapantes, de robustesse et d'hygiène.

Die Linie Aquae wurde für alle Projekte wie Swimming-Pools, Duschen und Wellness-Bereiche konzipiert. Mit ihrer reichen Auswahl an Looks, Materialien und Formstücken bietet Aquae architektonische Kontinuität in jedem Kontext sowie exzellente Resultate in Sachen Rutschfestigkeit, Beständigkeit und Hygiene.

Линия Aquae появилась на свет для удовлетворения потребностей проектирования в таких пространствах, как бассейны, душевые и зоны велнеса. Обладая большим ассортиментом образов, материалов и специальных изделий, Aquae обеспечивает наивысшую степень архитектурной поступательности в любом контексте, а также отличные результаты в отношении прочности, гигиены.



Info
Resources
Tools



Vantaggi

Advantages



Doppio spessore
Two thickness options
Double épaisseur
Doppelte Stärke
Две толщины



Alti standard igienici
A high standard of hygiene
Hauts niveaux d'hygiène
Hygiene auf höchstem Niveau
Высокие гигиенические стандарты

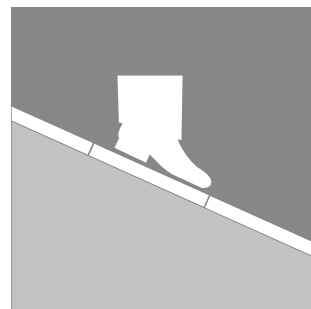

Tenuta antiscivolo
Anti-slip
Antidérapant
Rutsicher
Спротивление скольжению

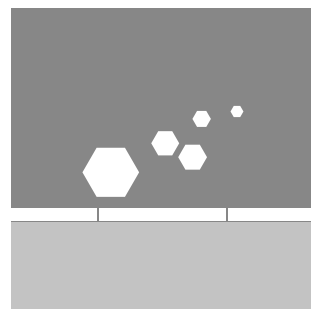

Resistente ai sali
Resistant to salts
Resistant aux sels
Salzbeständig
Стойкость к солям

Ampia gamma colori
Wide range of colours
Vaste gamme de couleurs
Reiche Farbpalette
Широкая цветовая палитра

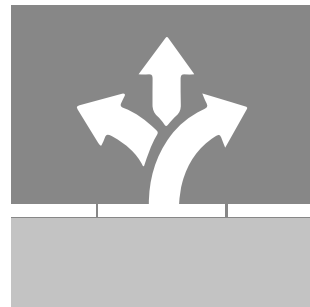

Estetica d'avanguardia
Cutting-edge aesthetics
Design d'avant-garde
Gelungene ästhetik
Передовая эстетика

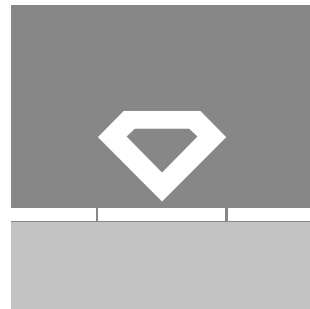

Resistente ai carichi
Resistant to loads
Résistant aux charges
Stark belastbar
Стойкость к весовым нагрузкам

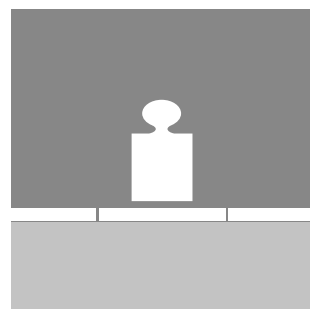

Assistenza ai progettisti
Assistance for builders
Assistance aux architectes
Service für die Planer
Помощь проектировщикам

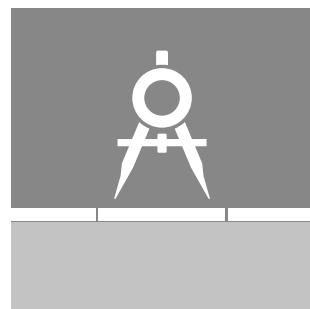

Soluzioni

Solutions

Griglia Shape - Grid - Grille - Gitter - Решётка Shape
Bordo Round - Edge - Bord - Ränder - Кромка Round

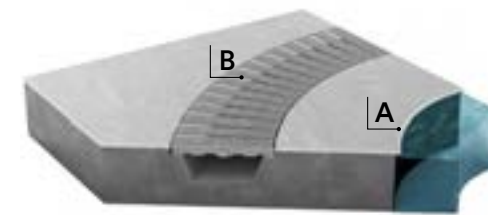

A / **Bordo Round** - Edge - Bord - Ränder - Кромка Round Aextra 20
B / **Griglia Shape** - Grid - Grille - Gitter - Решётка Shape Aextra 20
Vasche a sfioro con bordo curvo (Aextra20 - Standard Thickness)
Overflow pools with curved borders - Bassins à débordement avec bord courbe
Überlaufbecken mit kurvenförmigem Beckenrand - Переливные бассейны с фигурным бортом

Griglia Flexi_New - Grid - Grille - Gitter - Решётка Flexi_New
Bordo Round - Edge - Bord - Ränder - Кромка Round

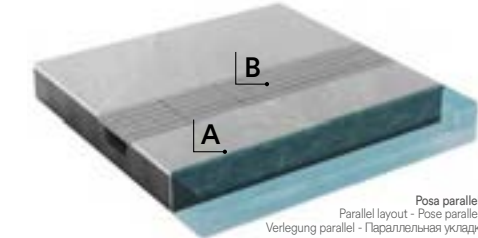

A / **Bordo Round** - Edge - Bord - Ränder - Кромка Round Aextra 20
B / **Griglia Flexi_New** - Grid - Grille - Gitter - Решётка Flexi_New
Vasche a "sfioro" con griglia (Aextra20 - Standard Thickness)
"Deck-level" swimming pools with grid - Piscines à bord déversant avec grille
Schwimmbad mit Gitterüberlauf - Переливные бассейны с решёткой

Griglia Flexi_New - Grid - Grille - Gitter - Решётка Flexi_New
Bordo Round - Edge - Bord - Ränder - Кромка Round

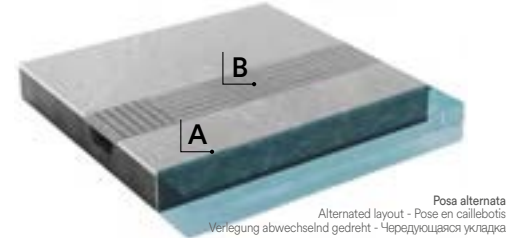

A / **Bordo Round** - Edge - Bord - Ränder - Кромка Round Aextra 20
B / **Griglia Flexi_New** - Grid - Grille - Gitter - Решётка Flexi_New
Vasche a "sfioro" con griglia (Aextra20 - Standard Thickness)
"Deck-level" swimming pools with grid - Piscines à bord déversant avec grille
Schwimmbad mit Gitterüberlauf - Переливные бассейны с решёткой

Griglia Blade - Grid - Grille - Gitter - Решётка Blade
Bordo Round - Edge - Bord - Ränder - Кромка Round

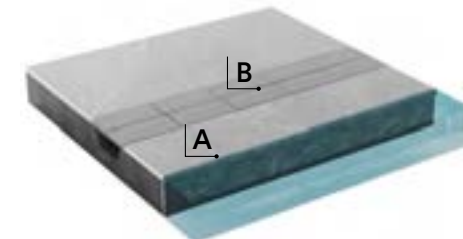

A / **Bordo Round** - Edge - Bord - Ränder - Кромка Round Aextra 20
B / **Griglia Blade** - Grid - Grille - Gitter - Решётка Blade
Vasche a "sfioro" con griglia (Aextra20 - Standard Thickness)
"Deck-level" swimming pools with grid
Piscines à bord déversant avec grille
Schwimmbad mit Gitterüberlauf
Переливные бассейны с решёткой

Griglia Bolt - Grid - Grille - Gitter - Решётка Bolt
Bordo Round - Edge - Bord - Ränder - Кромка Round

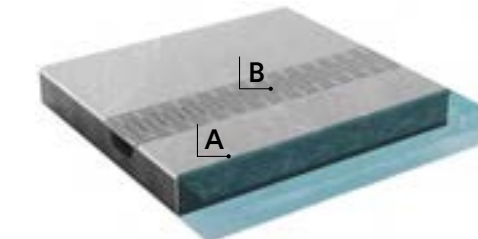

A / **Bordo Round** - Edge - Bord - Ränder - Кромка Round Aextra 20
B / **Griglia Bolt** - Grid - Grille - Gitter - Решётка Bolt
Vasche a "sfioro" con griglia (Aextra20 - Standard Thickness)
"Deck-level" swimming pools with grid
Piscines à bord déversant avec grille
Schwimmbad mit Gitterüberlauf
Переливные бассейны с решёткой

Griglia Blade - Grid - Grille - Gitter - Решётка Blade
Bordo Bend - Edge - Bord - Ränder - Кромка Bend

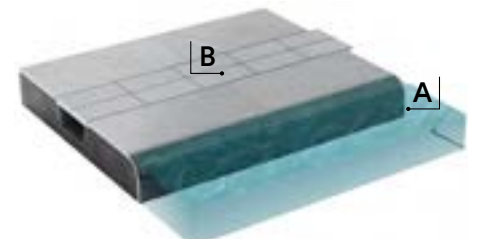

A / **Bordo Bend** - Edge - Bord - Ränder - Кромка Bend
B / **Griglia Blade** - Grid - Grille - Gitter - Решётка Blade
La soluzione a sfioro con griglia (Standard Thickness)
Swimming pools with overflow edges and standard thickness grids
La solution à débordement avec grille à épaisseur standard
Die überlauflösung mit rost in standardstärke
Переливные бассейны с решёткой стандартной толщины

Bordo Pool - Edge - Bord - Ränder - Кромка Pool

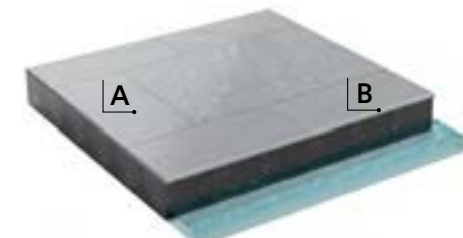

A / **Piastrella Tradizionale** - Traditional tile - Carreaux traditionnels
Traditionelle Fliesen - Традиционная плитка
B / **Bordo Pool** - Pool edge - bord Pool - Ränder Pool - Кромка Pool
Vasche a "skimmer"
"Skimmer" swimming pools - Piscines à « skimmer »
"Skimmer"-Schwimmbäder - Скиммерные бассейны

Griglia Wave - Grid - Grille - Gitter - Решётка Wave
Bordo Cascade - Edge - Bord - Ränder - Кромка Cascade



A / **Bordo Cascade** - Edge - Bord - Ränder - Кромка Cascade
B / **Griglia Wave** - Grid - Grille - Gitter - Решётка Wave
Vasche a "cascata"
Infinity edge pools - Piscines à cascade
Wasserfallbäder - Каскадные бассейны

Bordo Cascade - Edge - Bord - Ränder - Кромка Cascade



A / **Bordo Cascade** - Edge - Bord - Ränder - Кромка Cascade
Vasche a "cascata"
Infinity edge pools - Piscines à cascade
Wasserfallbäder - Каскадные бассейны

Bordo Round
Edge - Bord - Ränder - Кромка Round

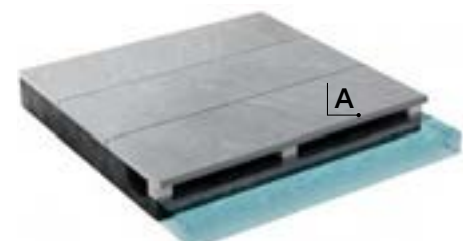

Vasche a "sfioro" interno (Tipo Wiesbaden)
Pools with internal deck-level edge (Wiesbaden type)
Piscines avec têtes de bassin à débordement (type Wiesbaden)
Becken mit Wiesbadener Überlaufrinne
Бассейны с внутренним переливным лотком (система wiesbaden)
A / **Bordo Round** - Edge - Bord - Ränder - Кромка Round Aextra 20

Pezzi speciali

Trims pieces

Bordi - Edges - Bords - Ränder - Кромки

STEP

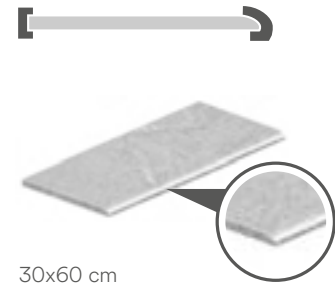

30x60 cm

BEND

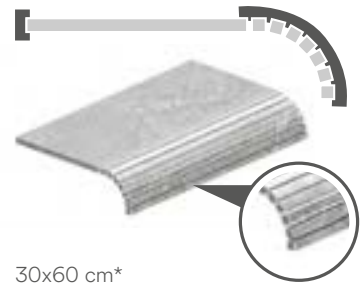

30x60 cm*

CASCADE

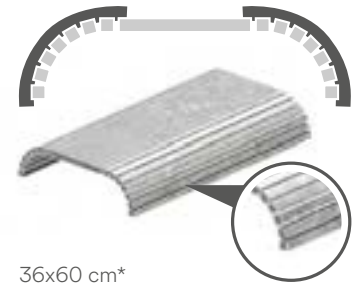

36x60 cm*

* Misura del pezzo steso.

Length of unfolded piece. Longueur étirée de la pièce. Länge des ausgebreiteten Teils. Размеры элемента

POOL

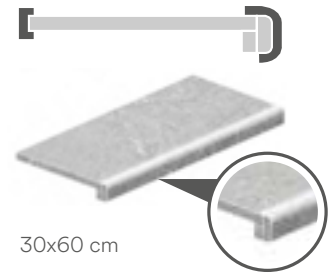

30x60 cm

POOL ANGOLARE CORNER

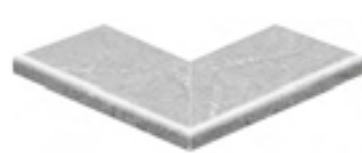

Angolo esterno
Corner - Angle - Ecke - Угол
30x60 cm



Angolo esterno
Corner - Angle - Ecke - Угол
30x60 cm

Griglie - Grids - Grilles - Gitter - Решётки

OVERLAY SP. 19-21 mm

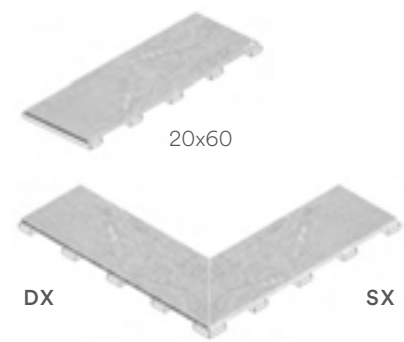

20x60

DX SX

Angolare
Corner - Angle - Ecke - Угол
20x60

WAVE SP. 19-21 mm

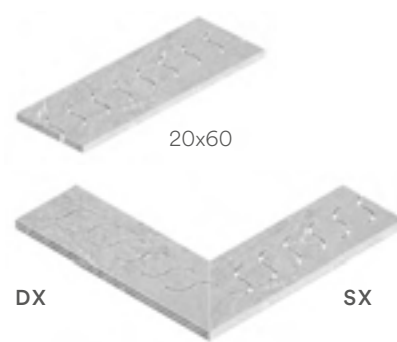

20x60

DX SX

Angolare
Corner - Angle - Ecke - Угол
20x60

Griglie - Grids - Grilles - Gitter - Решётки

FLEXI_NEW°

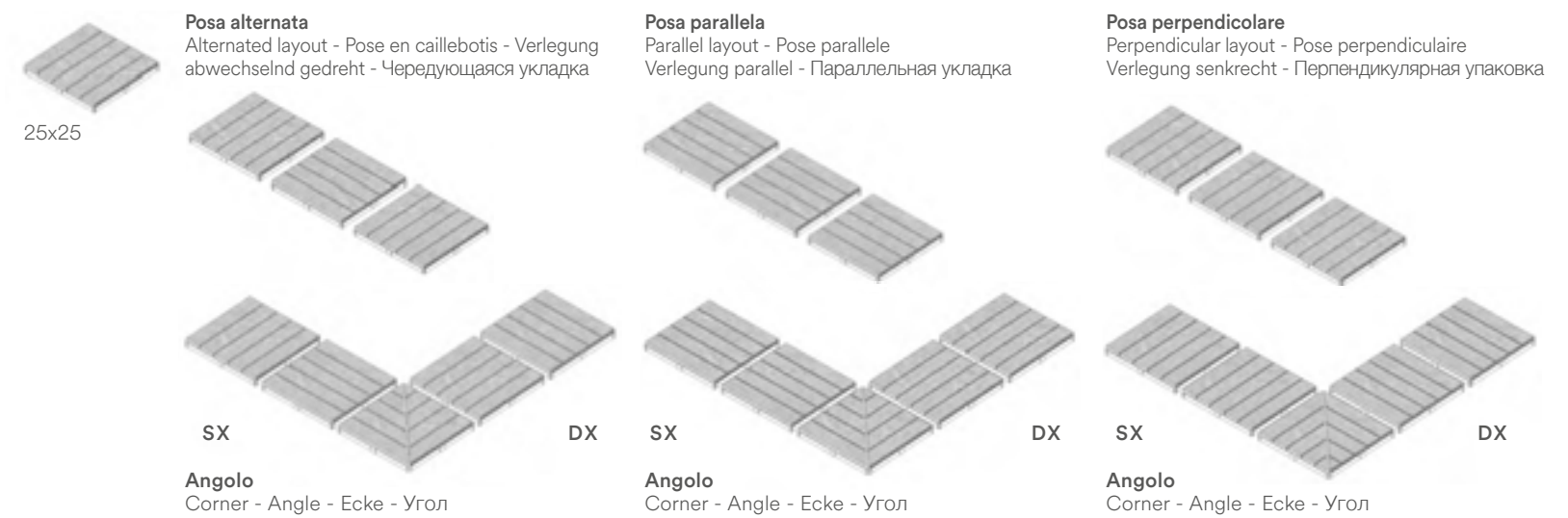

25x25

Posa alternata
Alternated layout - Pose en caillebotis - Verlegung abwechselnd gedreht - Чередующаяся укладка

Posa parallela
Parallel layout - Pose parallele - Verlegung parallel - Параллельная укладка

Posa perpendicolare
Perpendicular layout - Pose perpendiculaire - Verlegung senkrecht - Перпендикулярная упаковка

SX

DX

SX

DX

SX

DX

Angolo
Corner - Angle - Ecke - Угол

Angolo
Corner - Angle - Ecke - Угол

Angolo
Corner - Angle - Ecke - Угол

BLADE°

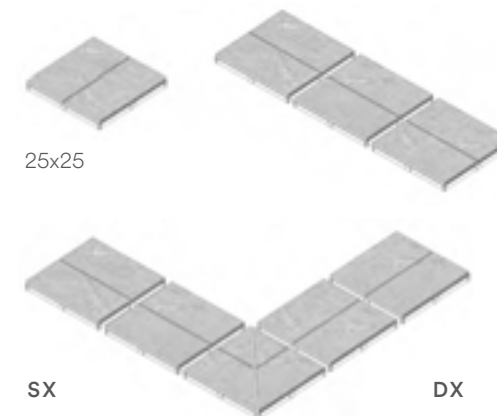

25x25

SX

DX

Angolo
Corner - Angle - Ecke - Угол

SHAPE°

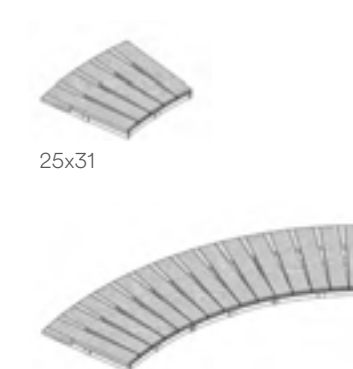

25x31

BOLT°

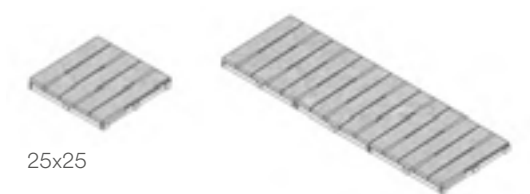

25x25

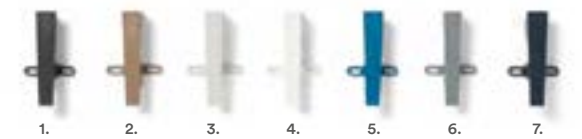

1. Grigio Umbro
2. Beige Perlato
3. Bianco Grigiastro
4. Naturale
5. Blu Genziana Perlato
6. Grigio Polvere
7. Grigio Scuro

Le griglie Shape e Bolt sono formate da listelli ceramici incollati su supporto in materiale plastico. Per garantire la curvatura (griglia Shape) o l'inclinazione (griglia Bolt) dei tozzetti, tra questi vengono inseriti degli appositi cunei, che possono essere personalizzati scegliendo tra diversi colori.

The Shape and Bolt grids consist of ceramic listels glued onto a plastic support. To guarantee curving (Shape grid) or tilting (Bolt grid) of dots, special wedges are inserted between the latter. Wedges can be customised by choosing one of the available colours. - Les grilles Shape et Bolt sont formées de listels céramiques collés sur un support en matière plastique. Des cales spécifiques, pouvant être personnalisées par différentes couleurs, sont insérées entre les cabochons pour en garantir la courbure (grille Shape) ou l'inclinaison (grille Bolt). - Die Überlaufrinnen Shape und Bolt bestehen aus auf Kunststoffträger verklebten Keramikleisten. Zur Erzielung der Bogenform (Shape) bzw. der Neigung (Bolt) der Einleger werden Keile eingefügt, die je nach Wunsch in verschiedenen Farben zur Verfügung lieferbar sind. - Решетки Shape и Bolt состоят из керамических реек, наклеенных на пластиковую основу. Для обеспечения изгиба (решетка Shape) или наклона (решетка Bolt) элементов, между ними устанавливаются специальные клинья, цвет которых может быть подобран индивидуально.

Le griglie Flexi_new, Blade, Shape e Bolt sono formate da listelli in grès spessore tradizionale (9-10 mm) incollati su supporto in ABS anti-UV in spessore 15 mm. Lo spessore totale è di 24-25 mm. The Flexi_new, Blade, Shape and Bolt grids consist of stoneware listels with a conventional thickness (9-10 mm), glued onto an ABS, anti-UV support with a thickness of 15 mm. The total thickness is 24-25 mm. - Les grilles Flexi_new, Blade, Shape et Bolt sont formées de listels en grès d'une épaisseur traditionnelle (9-10 mm) collés sur un support en ABS anti-UV de 15 mm d'épaisseur. L'épaisseur totale est de 24-25 mm. - Die Überlaufrinnen Flexi_new, Blade, Shape und Bolt bestehen aus auf 15 mm starkem Träger aus UV-beständigem ABS verklebten Feinsteinzeugleisten in traditioneller Stärke (9-10 mm). Die Gesamtstärke beträgt 24-25 mm. - Решетки Flexi_new, Blade, Shape и Bolt состоят из реек из керамогранита обычной толщины (9-10 мм), наклеенных на основу из УФ-стойкого пластика АБС толщиной 15 мм. Их общая толщина составляет 24-25 мм.

Pezzi speciali 20 mm

20 mm trims pieces

Bordi - Edges - Bords - Ränder - Кромки

XSTEP

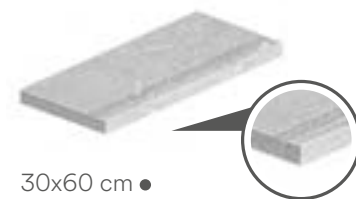

30x60 cm ●
30x80 cm ○
30x90 cm □*
30x120 cm ▲◇+

DX



SX

Angolare interno
Internal corner - Angle intérieur
Innenecke - Внутренний угол

30x60 cm ●
30x80 cm ○
30x90 cm □*
30x120 cm ▲◇+

DX

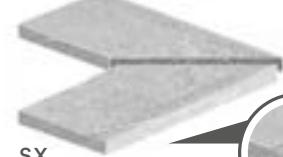

SX

Angolare esterno
External corner - Angle extérieur
Außenecke - Внешний угол

30x60 cm ●
30x80 cm ○
30x90 cm □*
30x120 cm ▲◇+

XGRIP

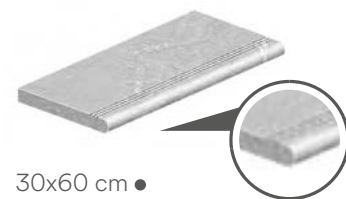

30x60 cm ●
30x80 cm ○
30x90 cm □*
30x120 cm ▲◇+

DX



SX

Angolare interno
Internal corner - Angle intérieur
Innenecke - Внутренний угол

30x60 cm ●
30x80 cm ○
30x90 cm □*
30x120 cm ▲◇+

DX

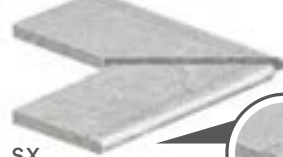

SX

Angolare esterno
External corner - Angle extérieur
Außenecke - Внешний угол

30x60 cm ●
30x80 cm ○
30x90 cm □*
30x120 cm ▲◇+

ROUND

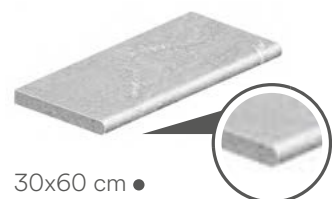

30x60 cm ●
30x80 cm ○
30x90 cm *
60x90 cm *
45x90 cm □
30x120 cm ▲◇+

DX



SX

Angolare interno
Internal corner - Angle intérieur
Innenecke - Внутренний угол

30x60 cm ●
30x80 cm ○
30x90 cm *
45x90 cm □
30x120 cm ▲◇+

DX



SX

Angolare esterno
External corner - Angle extérieur
Außenecke - Внешний угол

30x60 cm ●
30x80 cm ○
30x90 cm *
45x90 cm □
30x120 cm ▲◇+



60x60 cm ●
80x80 cm ○



Angolo round
Corner - Angle - Ecke - Угол

60x60 cm ●
80x80 cm ○



Angolo round dx
Corner - Angle - Ecke - Угол

30x60 cm ●
30x80 cm ○
30x90 cm *
45x90 cm □
30x120 cm ▲◇



Angolo round sx
Corner - Angle - Ecke - Угол

30x60 cm ●
30x80 cm ○
30x90 cm *
45x90 cm □
30x120 cm ▲◇

XSOLID



30x60 cm ●
30x80 cm ○
30x90 cm *
60x90 cm *
45x90 cm □
30x120 cm ▲◇+

DX



SX

Angolare interno
Internal corner - Angle intérieur
Innenecke - Внутренний угол

30x60 cm ●
30x80 cm ○
30x90 cm *
45x90 cm □
30x120 cm ▲◇+

DX



SX

Angolare esterno
External corner - Angle extérieur
Außenecke - Внешний угол

30x60 cm ●
30x80 cm ○
30x90 cm *
45x90 cm □
30x120 cm ▲◇+



Angolo dx
Corner - Angle - Ecke - Угол

30x60 cm ●
30x80 cm ○
30x90 cm *
45x90 cm □
30x120 cm ▲◇+



Angolo sx
Corner - Angle - Ecke - Угол

30x60 cm ●
30x80 cm ○
30x90 cm *
45x90 cm □
30x120 cm ▲◇+

CURVE

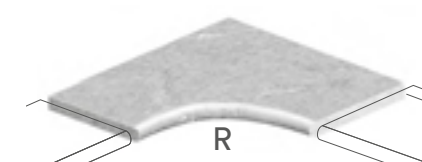

Angolare interno
Internal corner
Angle intérieur
Innenecke
Внутренний угол

60x60 cm ●▲+* R30 cm
80x80 cm ○ R30 cm

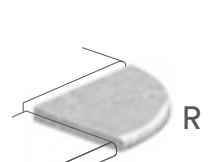

Angolare esterno
External corner
Angle extérieur
Außenecke
Внешний угол

30x30 cm ●▲+*○ R30 cm

ARRONDI

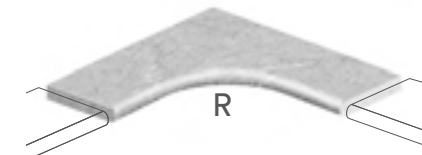

Angolare interno
Internal corner
Angle intérieur
Innenecke
Внутренний угол

60x60 cm ●▲+* R30 cm
80x80 cm ○ R20,5 cm

Disponibile nei colori che hanno fondo: - Available in colours offered in the: - Disponible dans les coloris disposant du format: - Lieferbar in allen Farben, die im Format verfügbar sind: - Поставляется в цветах, для которых предусмотрен формат

● 60x60 / ○ 80x80 / □ 45x90 / * 60x90 / ◇ 30x120 / ▲ 60x120 / + 120x120

★ Disponibile in tutti i colori Aextra20 - Available in all colors of Aextra20 range - Disponibles dans tous les coloris de la gamme Aextra20
In allen Farben der Reihe Aextra20 erhältlich - Доступны во всех цветах гаммы Aextra20

Pezzi speciali 20 mm

20 mm trims pieces

Griglie - Grids - Grilles - Gitter - Решётки

FLEXI_NEW°

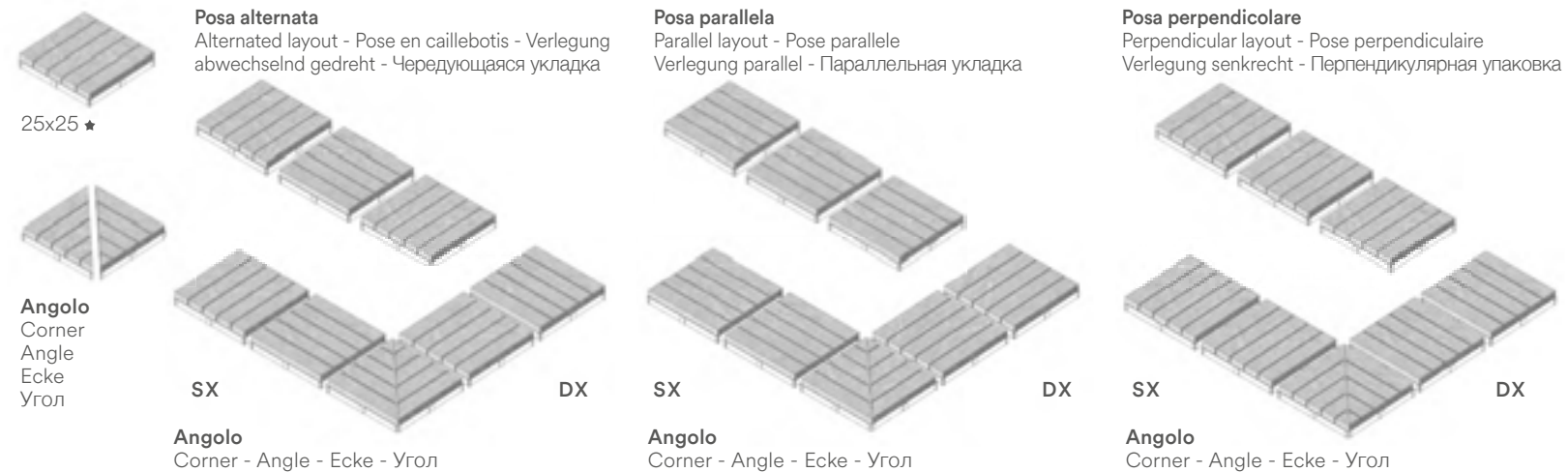

BLADE°

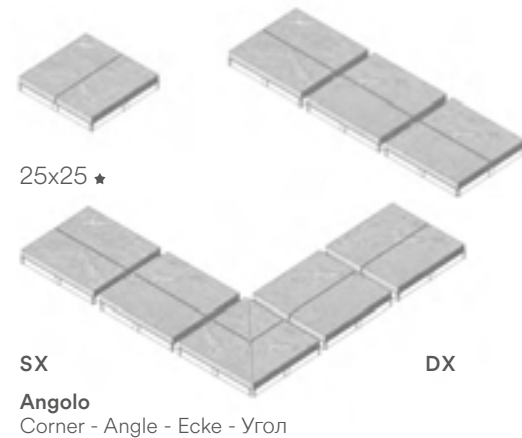

STRIPE

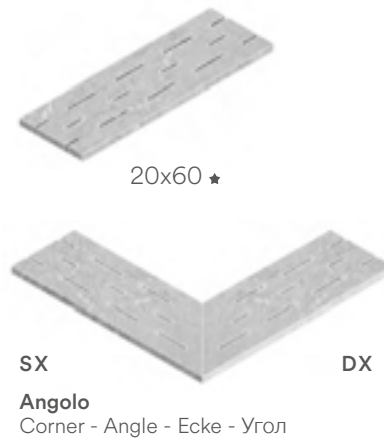

SHAPE°

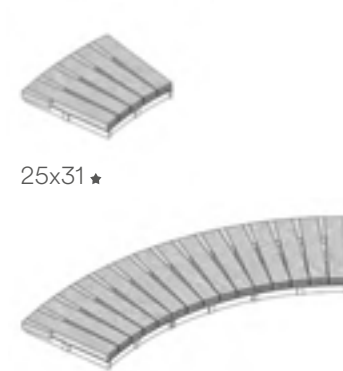

BOLT

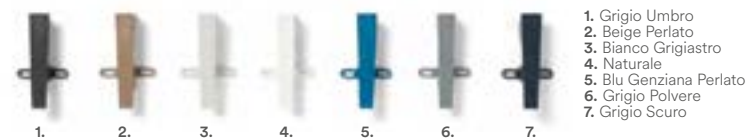
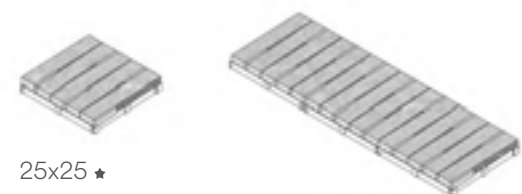

Le griglie Shape e Bolt sono formate da listelli ceramici incollati su supporto in materiale plastico. Per garantire la curvatura (griglia Shape) o l'inclinazione (griglia Bolt) dei tozzetti, tra questi vengono inseriti degli appositi cunei, che possono essere personalizzati scegliendo tra diversi colori. - The Shape and Bolt grids consist of ceramic listels glued onto a plastic support. To guarantee curving (Shape grid) or tilting (Bolt grid) of dots, special wedges are inserted between the latter. Wedges can be customised by choosing one of the available colours. - Les grilles Shape et Bolt sont formées de listels céramiques collés sur un support en matière plastique. Des cales spécifiques, pouvant être personnalisées par différentes couleurs, sont insérées entre les cabochons pour en garantir la courbure (grille Shape) ou l'inclinaison (grille Bolt). - Die Überlaufrinnen Shape und Bolt bestehen aus auf Kunststoffträger verklebten Keramikleisten. Zur Erzielung der Bogenform (Shape) bzw. der Neigung (Bolt) der Einleger werden Keile eingefügt, die je nach Wunsch in verschiedenen Farben zur Verfügung lieferbar sind. - Решетки Shape и Bolt состоят из керамических реек, наклеенных на пластиковую основу. Для обеспечения изгиба (решетка Shape) или наклона (griglia Bolt) элементов, между ними устанавливаются специальные клинья, цвет которых может быть подобран индивидуально.

Le griglie Flexi_new, Blade, Shape e Bolt Aextra20 sono formate da listelli in gres Aextra20 incollati su supporto in ABS anti-UV in spessore 15 mm. Lo spessore totale è di 35 mm. The Flexi_new, Blade, Shape and Bolt Aextra20 grids consist of Aextra20 stoneware listels, which are glued onto an ABS, anti-UV support with a thickness of 15 mm. The total thickness is 35 mm. - Les grilles Flexi_new, Blade, Shape et Bolt Aextra20 sont formées de listels en gres Aextra20 collés sur un support en ABS anti-UV de 15 mm d'épaisseur. L'épaisseur totale est de 35 mm. - Die Überlaufrinnen Flexi_new, Blade, Shape und Bolt Aextra20 bestehen aus auf 15 mm starkem Träger aus UV-beständigem ABS verklebten Aextra20-Feinsteinzeugleisten. Die Gesamtstärke beträgt 35 mm. - Решетки Flexi_new, Blade, Shape и Bolt Aextra20 выполнены из керамогранитных реек Aextra20, наклеенных на основу из УФ-стойкого пластика ABS толщиной 15 мм. Их общая толщина составляет 35 мм.



Floor: E.MOTIONS SANDY WHITE 60x60 GRIP RT R11 C. ROUND, FLEXI_NEW

Cover wall system



La soluzione ideale per le facciate esterne. Tecniche applicative innovative e sicure. Soluzioni estetiche esclusive e personalizzate. Consulenza della Divisione CaesarTech Solutions. Ampia scelta di colori, formati e spessori.

The perfect solution for external facades. Innovative and safe applications for personalized aesthetic solutions. Caesar Tech Solutions offers consultancy services to create successful projects utilizing the broad selection of colors, sizes, and thicknesses.

La solution idéale pour les façades extérieures. Techniques d'application innovatrices et sûres. Solutions esthétiques exclusives et personnalisées. Service de consultation de la Divisione CaesarTech Solutions. Vaste choix de couleurs, formats et épaisseurs.

Die ideale Lösung für Außenfassaden. Innovative und sichere Anwendungstechniken. Exklusive und personalisierte optische Lösungen. Beratung durch den Geschäftsbereich CaesarTech Solutions. Große Auswahl an Farben, Formaten und Stärken.

Идеальное решение для фасадов. Инновационные и безопасные способы монтажа. Индивидуальные эстетические решения. Консультационная поддержка подразделения CaesarTech Solutions. Богатый выбор цветов, форматов, толщин.



Info
Resources
Tools



Floor: IULIA 30x60 - 22,5x45,3 - 22,5x22,5 TEXTURED NR R11 C
Wall: IULIA 120x278 MATT RT, 30x60 TEXTURED NR R11 C

Vantaggi

Advantages

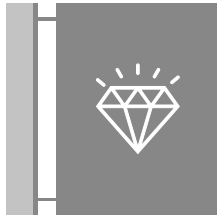

Pregio estetico
Prestigious appearance
Valeur esthétique
Hochwertige Optik
Удачная эстетика



Molteplici look
Many different looks
Looks multiples
Vielfältige Looks
Множество вариантов оформления

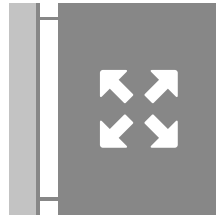

Varietà di formati
A variety of sizes
Variété de formats
Formatvielfalt
Разнообразие форматов

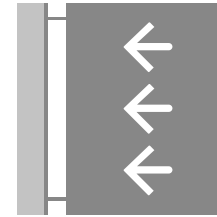

Benessere termico
Thermal comfort
Bien-être thermique
Thermischer Komfort
Комфортный микроклимат

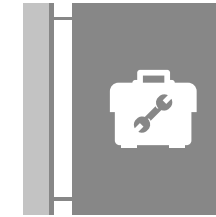

Soluzioni per ristrutturazioni
Solutions for renovation
Solutions pour restructurations
Lösungen für die Bausanierung
Решения для реконструкции

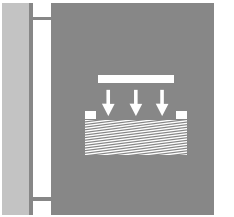

Posa a secco
Dry-system installation
Pose à sec
Trockenverlegung
Сухой укладки

Soluzioni . Solutions



Facciate ventilate a scomparsa

Nelle facciate ventilate a scomparsa il sistema di ancoraggio delle lastre non è visibile sulla superficie. Ciò permette di avere una resa estetica omogenea che valorizza al massimo il valore delle lastre ceramiche Caesar.

Concealed ventilated walls

In concealed ventilated wall systems, the slab anchoring systems are not visible on the surface. This offers a smooth appearance that brings out the best of Caesar ceramic slabs.

Façades ventilées invisibles

Sur les façades ventilées invisibles, le système de fixation des plaques ne se voit pas en surface, ce qui permet d'obtenir un effet esthétique homogène qui valorise au maximum les dalles de céramique Caesar.

Hinterlüftete Fassaden Mit Verdeckten Haken

Bei hinterlüftete Fassaden mit verdeckten Haken ist das Verankerungssystem der Platten an der Oberfläche nicht sichtbar. So entsteht eine einheitliche Optik, die den Wert der Keramikplatten von Caesar maximal zur Geltung bringt.

Вентилируемые фасады со скрытыми креплениями

На вентиляруемых фасадах со скрытыми креплениями система анкерки плит не видна на поверхности. Таким образом, создается однородная эстетика, максимально подчеркивающая красоту керамических плит Caesar.



Facciate ventilate a scomparsa Aextra20

Le facciate ventilate a scomparsa, caratterizzate da un sistema di ancoraggio non visibile in superficie e pertanto in grado di valorizzare al massimo le lastre ceramiche Caesar, possono essere realizzate anche con i materiali spessorati 20mm della linea Aextra 20.

Aextra20 concealed ventilated walls

Concealed ventilated walls, featuring concealed anchoring systems, which can therefore highlight all the beauty of Caesar slabs, can also be built using 20 mm thick slabs of the Aextra 20 line.

Façades ventilées invisibles Aextra20

Les façades ventilées invisibles, caractérisées par un système de fixation qui ne se voit pas en surface et qui donc est en mesure de valoriser au maximum les dalles céramiques Caesar, peuvent également être réalisées avec les matériaux à épaisseur majorée (20 mm) de la ligne Aextra 20.

Hinterlüftete Fassaden Mit Verdeckten Haken Aextra20

Die hinterlüfteten Fassaden mit verdeckten Haken, die mit ihrem von außen unsichtbaren Befestigungssystem die Keramikplatten von Caesar besonders gut zur Geltung bringen, können auch mit den 20 mm starken Paletten der Linie Aextra 20 ausgeführt werden.

Вентилируемые фасады с облицовкой из плиток Aextra20 и скрытыми креплениями. Вентилируемые фасады со скрытыми креплениями, которые характеризуются незаметной на поверхности системой анкерки и, поэтому, максимально выгодно показывают красоту керамических материалов Caesar, могут выполняться также с применением материалов с увеличенной толщиной 20 мм из линейки Aextra 20.



Facciate ventilate multiformato

Le facciate ventilate multiformato non sono realizzate con singole piastrelle, bensì con pannelli ancorati alla parete sui quali è possibile collocare anche più lastre, e di formati diversi, dando vita a moduli multiformato replicabili sull'intera parete.

Multi-size ventilated walls

Multi-size ventilated walls are not made up of single tiles but of panels anchored to the wall, which can carry several slabs, also of different sizes, to create multi-size modules that can be replicated all over the wall.

Façades ventilées multiformat

Les façades ventilées multiformat ne sont pas réalisées avec des dalles individuelles, mais avec des panneaux fixés au mur sur lesquels il est possible de placer encore plus de dalles, dans différentes tailles, en créant des modules multiformat répliquables sur l'ensemble du mur.

Mehrformatige Hinterlüftete Fassaden

Die mehrformatigen hinterlüfteten Fassaden bestehen nicht aus einzelnen Fliesen, sondern aus an der Wand verankerten Tafeln, an denen auch mehrere und unterschiedlich große Fliesen fixiert werden können. Daraus entstehen mehrformatige Module, die über die ganze Wand wiederholt werden können.

Вентилируемые фасады с мультиформатной облицовкой

Вентилируемые фасады с мультиформатной облицовкой состоят не из отдельных плит, а из прикрепленных к стене панелей, на которые устанавливаются несколько плит разных форматов, образуя мультиформатные модули, которые могут повторяться по всей облицовываемой стене.



Facciate ventilate con gancio a vista

Nelle facciate ventilate con gancio a vista, il sistema di ancoraggio delle lastre è visibile sulla superficie. Ciò consente di montare e smontare ogni singola lastra in facciata in maniera autonoma e senza alcuna lavorazione, con costi estremamente contenuti. Inoltre, i ganci di supporto possono essere verniciati dello stesso colore delle lastre, permettendo una perfetta ed omogenea resa estetica.

Ventilated walls with visible hooks

In ventilated wall systems with visible hooks, the slab anchoring systems are visible on the surface. This makes it possible to remove single slabs separately and with no particular work at extremely low costs. Supporting hooks can be painted the same colour as the slabs to offer a smooth and even appearance.

Façades ventilées avec système de fixation apparent

Sur ce genre de façades, le système de fixation des dalles est visible en surface, ce qui permet de poser et d'enlever chaque dalle individuellement sur la façade, indépendamment et sans aucun traitement, à un coût extrêmement faible. De plus, les crochets de support peuvent être peints dans la même couleur que les dalles, pour un effet esthétique parfait et homogène.

Hinterlüftete Fassaden Mit Sichtbaren Haken

Bei den hinterlüfteten Fassaden mit sichtbaren Haken ist das Verankerungssystem der Platten von außen sichtbar. Der Vorteil liegt darin, dass jede einzelne Platte an der Fassade mit deutlich reduzierten Installationskosten unabhängig und ohne jede Bearbeitung montiert werden kann. Die Verankerungshaken können für eine perfekt gleichmäßige Optik in derselben Farbe der Platten lackiert werden.

Вентилируемые фасады с видимыми креплениями

На вентиляруемых фасадах с видимыми креплениями система анкерки плит видна на поверхности. Это позволяет монтировать и демонтировать каждую плитку фасада отдельно, без выполнения каких-либо дополнительных работ, при очень низких расходах. Кроме того, опорные крепления могут окрашиваться в цвет плит, создавая однородный результат с привлекательной эстетикой.

Misura

CAESARTECH

Customisation



Con Misura CaesarTech mette a disposizione una pluriennale esperienza e una ricca gamma di pezzi speciali per soddisfare la crescente necessità di progetti personalizzati. A seconda delle esigenze, il servizio può proporre schemi di posa, abbinamenti colore e soluzioni custom sotto forma di visual 2D, render o disegni esecutivi.

With Misura, CaesarTech offers many years of experience and a rich assortment of trim pieces to cater for the growing need for customized projects. Depending on the requirements, the service offers installation patterns, colour matches and custom solutions by means of 2D visual systems, renderings and construction drawings.

Avec Misura, CaesarTech valorise ses nombreuses années d'expérience et propose une large gamme de pièces spéciales afin de satisfaire la demande croissante de projets personnalisés. Selon les attentes, ce service propose des schémas de pose, des associations de couleurs et des solutions personnalisées sous forme de visuels 2D, de rendus ou de dessins d'exécution.

Mit Misura stellt CaesarTech seine langjährige Erfahrung und ein reiches Angebot an Formstücken zur Verfügung, um dem wachsenden Bedarf personalisierter Projekte gerecht zu werden. Je nach Bedarf werden Verlegeschemen, Farbkombinationen und kundenspezifische Lösungen in Form von 2D-Ansichten, Renderings oder Ausführungszeichnungen bereitgestellt.

При помощи Misura CaesarTech предоставляет в распоряжение многолетний опыт и богатый ассортимент специальных изделий для удовлетворения постоянно растущей необходимости реализации индивидуальных проектов. В зависимости от необходимости, этот сервис может предлагать схемы укладки, сочетания цвета и индивидуальные решения в виде изображений 2D, рендеров или исполнительных чертежей.



Info
Resources
Tools

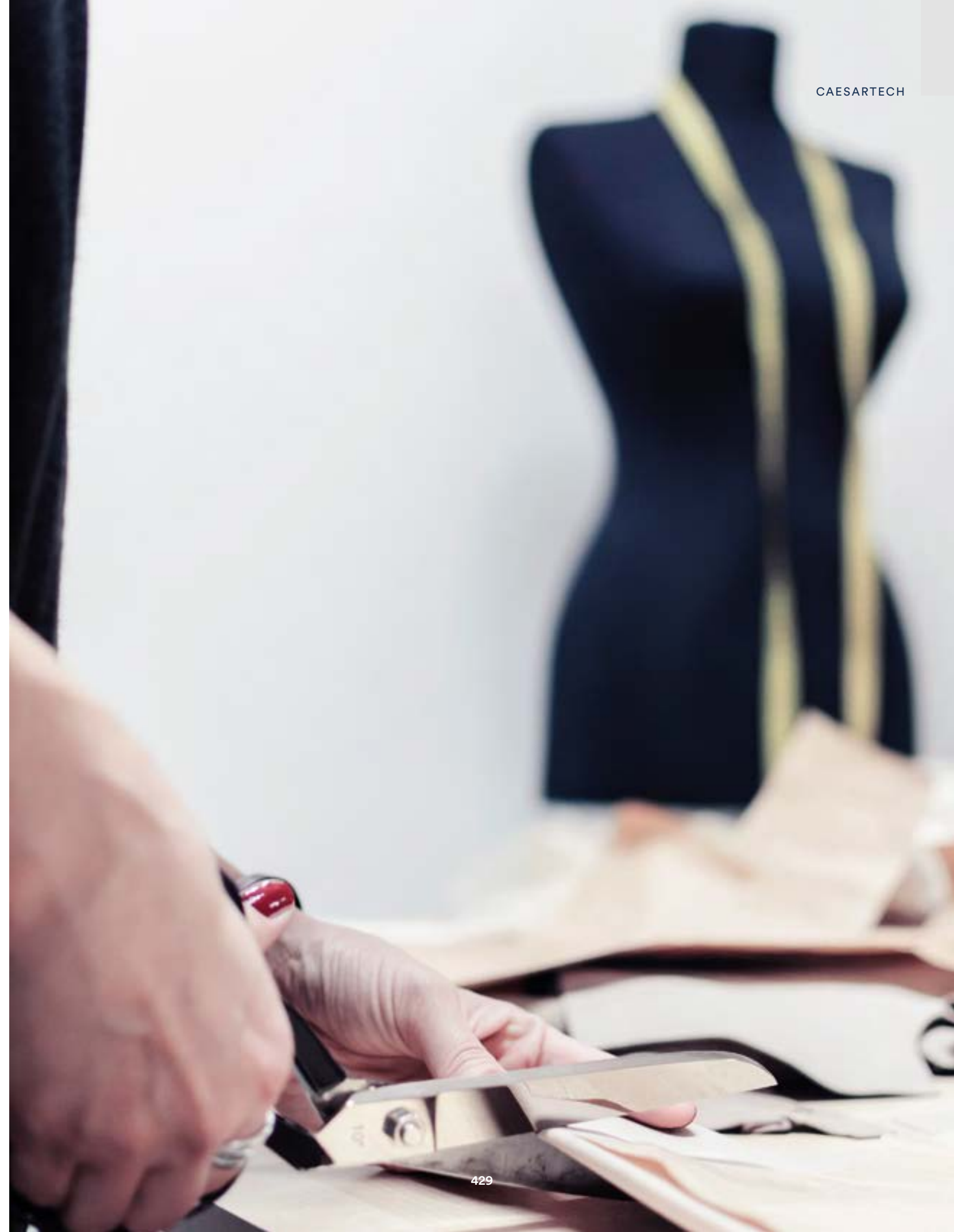

Soluzioni

Solutions

VISUAL 2D / 3D

Ove materiali e formati sono stati preventivamente selezionati dal cliente, determinati progetti, possono usufruire del servizio visual 2D o 3D. In questo modo è possibile proporre abbinamenti di colore, schemi di posa e facilitare la comprensione di soluzioni tecniche e utilizzo di pezzi speciali.

2D-3D VISUAL SYSTEMS

Whenever materials and sizes have been chosen by the customer, certain projects can take advantage of the 2D or 3D visual service. In this manner, it is possible to present colour matches and installation patterns, and facilitate the comprehension of technical solutions and the use of trim pieces.

VISUAL 2D-3D

Lorsque les matériaux et les formats ont été préalablement sélectionnés par le client, certains projets peuvent faire appel au service visual 2D ou 3D. Il est ainsi possible de proposer des combinaisons de couleurs, des motifs de pose et de faciliter la compréhension des solutions techniques et l'utilisation de pièces spéciales.

VISUAL 2D-3D

Hat der Kunde vorab Materialien und Formate ausgewählt, so kann für bestimmte Projekte der Service visual 2D bzw. 3D genutzt werden. So können Farbkombinationen und Verlegemuster vorgeschlagen werden, und die technischen Lösungen sowie der Einsatz von Formstücken werden leicht verständlich dargestellt.

2D-3D ИЗОБРАЖЕНИЯ

Если клиент уже выбрал материалы и форматы, определенные проекты могут быть представлены при помощи 2D и 3D изображений. Таким образом можно предложить цветовые сочетания, схемы укладки и наглядно показывать технические решения и использование специальных элементов.

PROGETTO HOTEL

Hotel Project - Projet Hôtel - Hotelprojekt - Проект Гостиницы

Disegni architettonici ricevuti dal cliente
Architectural drawings received from the customer
Dessins architecturaux envoyés par le client
Bauzeichnungen Des Kunden
Архитектурные чертежи, предоставленные клиентом

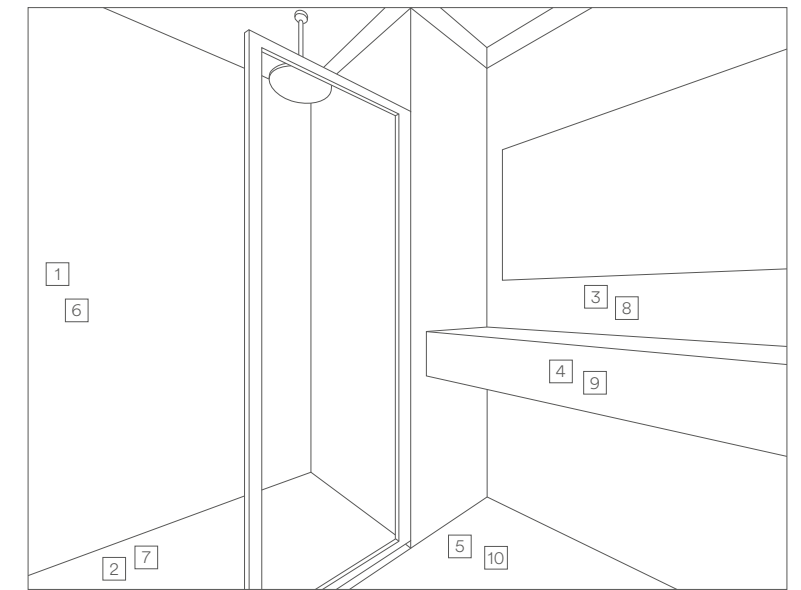
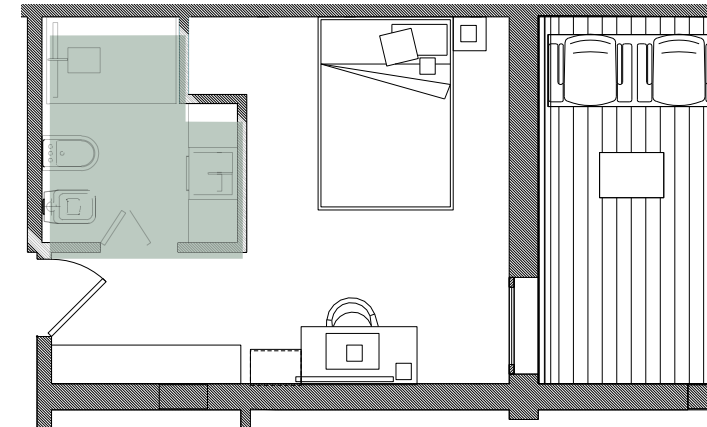

Visualizzazione in 3d della proposta progettuale
3D view of the project - Visualisation 3D du projet proposé
3D-Darstellung Des Projektvorschlags - 3D-рендеринг предложенного проекта

PROGETTO PISCINA PRIVATA

Private swimming pool project - Projet piscine privée - Swimming-Pool-Projekt - Проект частного бассейна

Disegni architettonici ricevuti dal cliente
Architectural drawings received from the customer
Dessins architecturaux envoyés par le client
Bauzeichnungen Des Kunden
Архитектурные чертежи, предоставленные клиентом

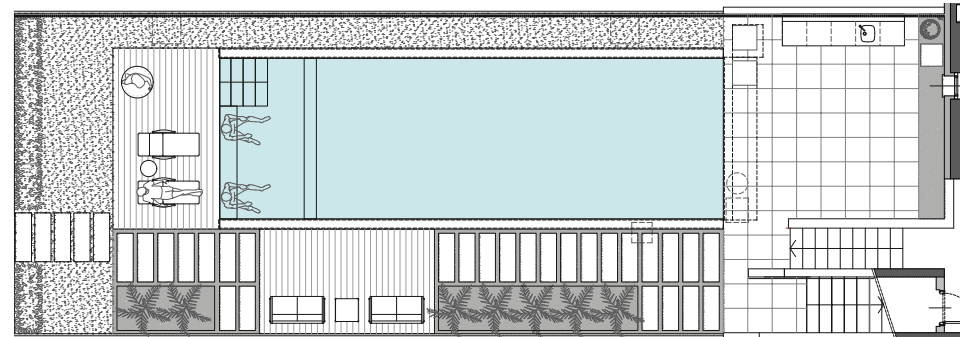

Visualizzazione in pianta della proposta progettuale
Plan view of the project
Visualisation sur plan du projet proposé
Draufsicht Des Vorgeschlagenen Projekts
Вид в плане предложенного проекта

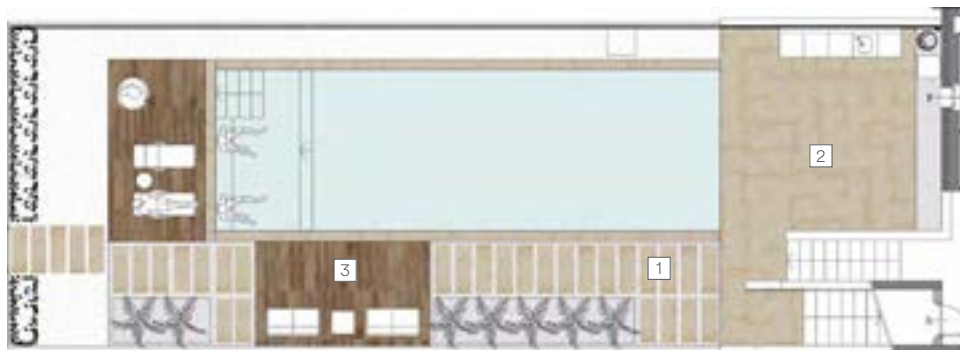

- 1 - Aextra20 Roxstones Golden Stone 60x120
- 2 - Roxstones Golden Stone 60x60 Soft
- 3 - Vibe Quercia 20x120 Grip

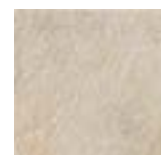

ROXSTONES
Golden Stone



VIBE
Quercia



- 1 - Nicchia Doccia - Shower enclosure - Niche douche - Duschnische - Душевая ниша
Kirkby 120x240
- 2 - Pav. Doccia - Shower floor - Carrel. douche - Duschenboden - Пол душа
Kirkby 60x60 Strutturato
- 3 - Rivestimento - Wall tiling - Revêtement - Wandverkleidung - Облицовка
Statuario 120x240
- 4 - Lavandino - Washbasin - Lavabo - Waschbecken - Умывальник
Statuario
- 5 - Pav. Bagno - Bathroom floor tiling - Carrel. salle de bains - Badezimmerboden - Пол ванной комнаты
Statuario 60x120
- 6 - Nicchia - Shower enclosure - Niche douche - Duschnische - Душевая ниша
Faro 120x240
- 7 - Pav. Doccia - Shower floor - Carrel. douche - Duschenboden - Пол душа
Faro 60x60 Strutturato
- 8 - Rivestimento - Wall tiling - Revêtement - Wandverkleidung - Облицовка
Faro 120x240
- 9 - Lavandino - Washbasin - Lavabo - Waschbecken - Умывальник
Faro
- 10 - Pav. Bagno - Bathroom floor tiling - Carrel. salle de bains - Badezimmerboden - Пол ванной комнаты
Faro 60x120



ANIMA
Statuario Venato



PORTRAITS
Kirkby



PORTRAITS
Faro

Soluzioni

Solutions

PERSONALIZZAZIONI

Per alcuni progetti specifici è possibile avvalersi di un supporto tecnico ancora più approfondito. Partendo da una richiesta progettuale ben definita, supportata preferibilmente da disegni in formato .dwg, Caesartech è in grado di restituire disegni tecnici che descrivono soluzioni totalmente personalizzate, o modifiche a pezzi speciali già a catalogo.

CUSTOMISATION

For certain specific projects, one can also take advantage of more in-depth technical support. Starting from a well-defined enquiry, preferably with the provision of drawings in .dwg format, Caesartech can develop technical drawings that illustrate totally customised solutions or modifications to existing trim pieces.

PERSONNALISATIONS

Un support technique encore plus approfondi a été prévu pour certains projets spécifiques. À partir d'une demande de conception bien précise, accompagnée de préférence de dessins au format .dwg, Caesartech est en mesure de renvoyer des dessins techniques décrivant des solutions totalement personnalisées, ou des modifications à des pièces spéciales déjà présentes au catalogue.

PERSONALISIERUNGEN

Für einige Projekte kann eine noch umfassendere technische Unterstützung in Anspruch genommen werden. Ausgehend von einer klar definierten und nach Möglichkeit mit Zeichnungen im Format .dwg versehenen Projektanfrage kann Caesartech technische Zeichnungen vollkommen personalisierter Lösungen bzw. Änderungen von bereits im Katalog vorhandenen Formstücken erstellen.

ИНДИВИДУАЛИЗИРОВАННОЕ ОФОРМЛЕНИЕ

Для некоторых конкретных проектов может быть предложена еще более тщательная техническая поддержка. Исходя из строго определенного проектного запроса, желательно с приложением чертежей в формате .dwg, Caesartech может разрабатывать технические чертежи, изображающие полностью индивидуализированные решения или изменения, внесенные в уже имеющиеся в каталоге специальные элементы.

PROGETTO PISCINA

Swimming pool project - Projet piscine - Swimming Pool-Projekt - Проект бассейна

Opzione proposta ed accettata dal cliente

Option suggested and accepted by the customer - Option proposée et acceptée par le client
Vom Kunden Angenommener Vorschlag - Предложенный вариант, принятый клиентом

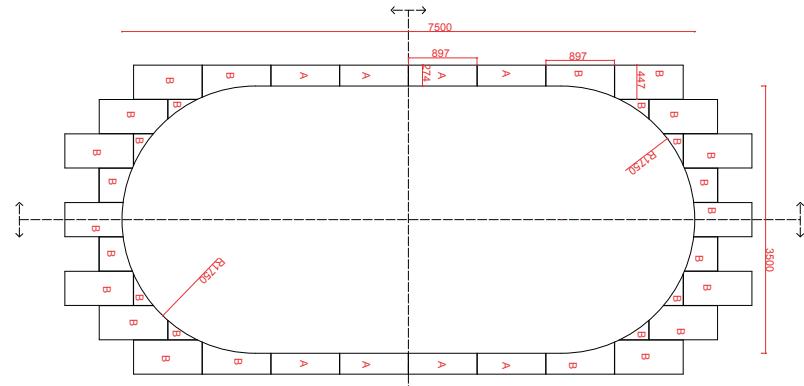

B PISCINA FUORI STANDARD

B Swimming pool with custom size - B Piscine hors norme
B Swimming-Pool - Sonderausführung - Нестандартный бассейн

FONDO:

Base: - Fond: - Grundfliese: - Плитка: Aextra 20 SP. 2 cm, 45x90

BORDO:

Border: - Bord: - Beckenrand: - Борт:

A: 8 pz. 274x897 da fondo 447x897 bordo lato piscina retto.

A: 8 pcs 274x897 for the 447x897 base, straight swimming pool side border.

A: 8 pièces 274x897 à fond 447x897 bord côté piscine droit.

A: 8 Fliesen 274x897 aus Bodenfliese 447x897 gerader Beckenrand.

A: 8 шт. 274x897, полученных из плитки 447x897 с прямоугольной кромкой со стороны бассейна.

B: 30 pz. con taglio curvo da fondo 447x897 bordo lato piscina retto.

B: 30 pcs with curved cut for the 447x897 base, straight swimming pool side border.

B: 30 pièces avec découpe fond 447x897 bord côté piscine droit.

B: 30 Fliesen mit gebogenem Schnitt aus Bodenfliese 447x897 gerader Beckenrand.

B: 30 шт. с криволинейным срезом, полученных из плитки 447x897 с прямоугольной кромкой со стороны бассейна.



PROGETTO SCALA / 60x120 KIRBY

Project developed / 60x120 Kirby - Projet escalier / 60x120 Kirby - Treppenprojekt / 60x120 Kirby - Проект лестницы / 60x120 Kirby

Disegno personalizzato eseguito per il cliente

Customised drawing provided by the customer - Dessin personnalisé effectué pour le client
Personalisierte Zeichnung Für Den Kunden - индивидуальное оформление, созданное для клиента

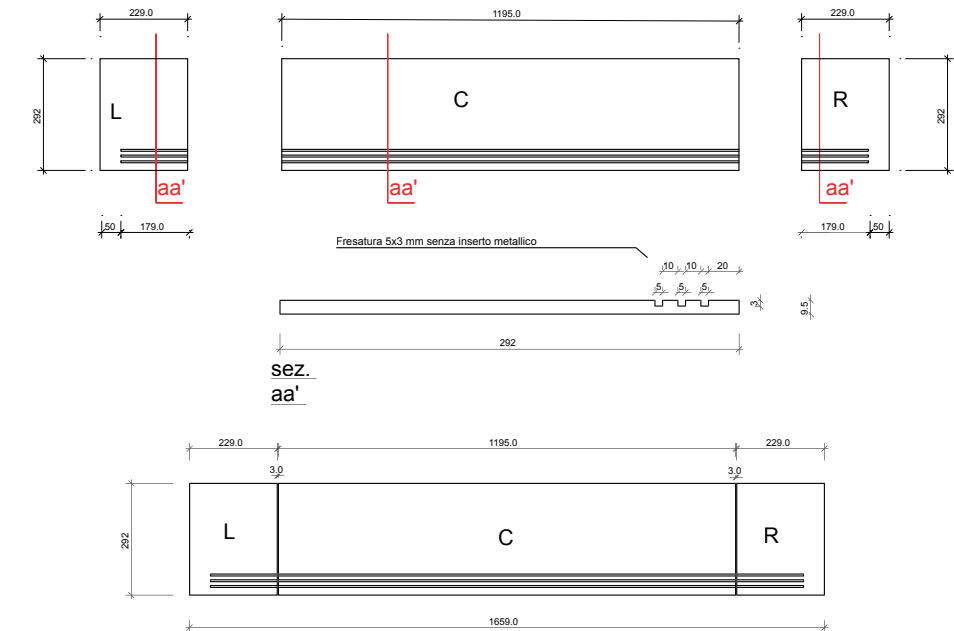

Progetto realizzato

Project developed - Projet réalisé - Ausgeführtes Projekt - Выполненный проект

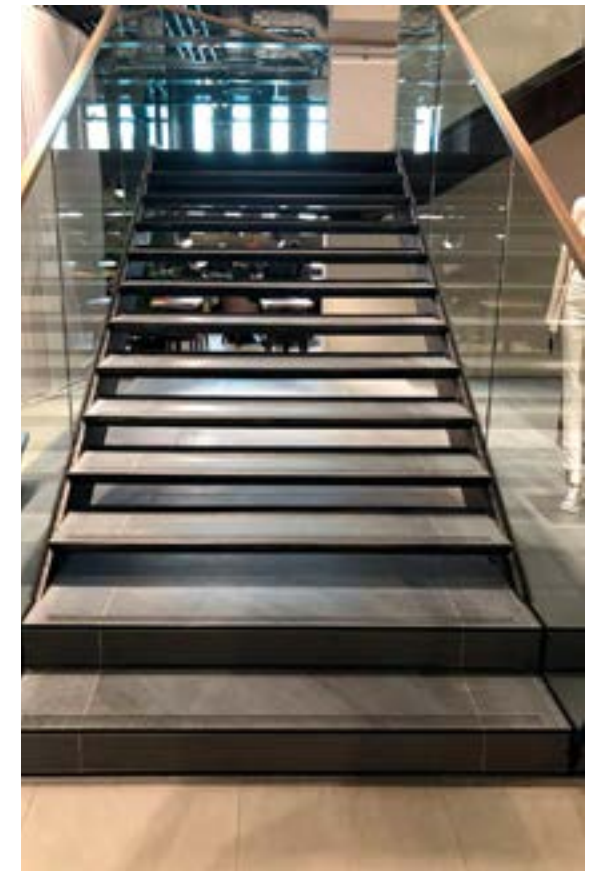
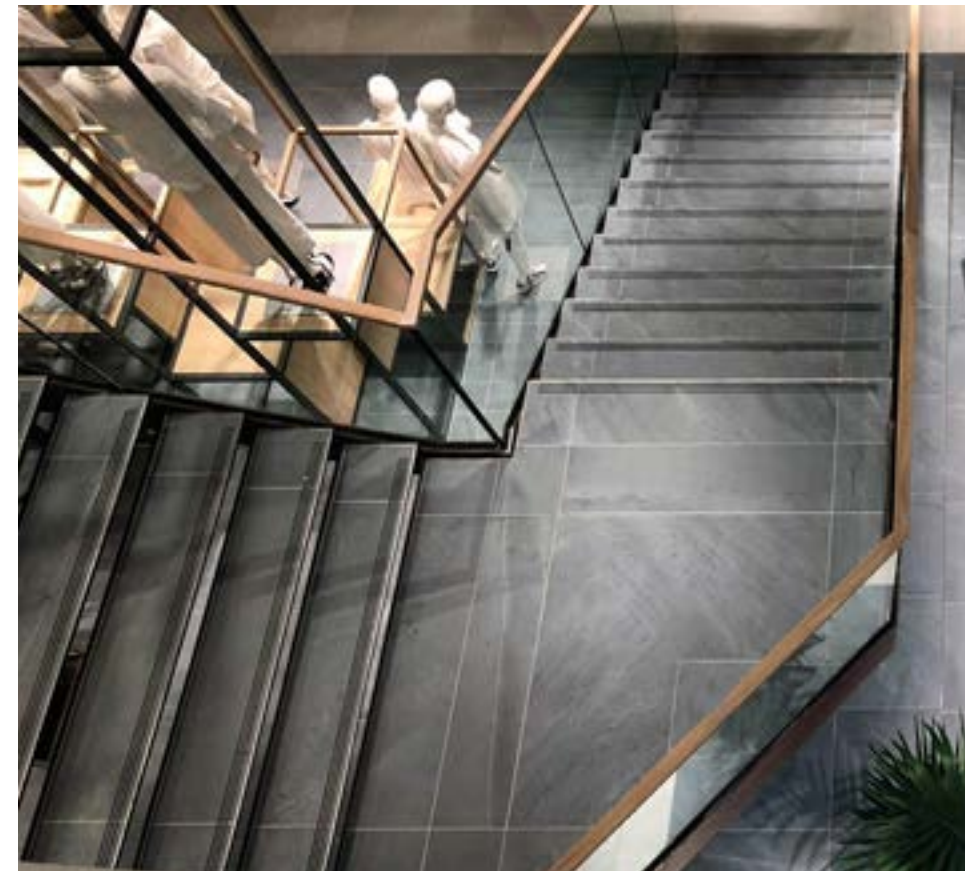

Safety

Safe guidance



I pavimenti tattili di Caesar si compongono di superfici dotate di rilievi, percepibili al passaggio, per consentire ai non vedenti e agli ipovedenti di orientarsi nei luoghi e riconoscere distintamente gli ostacoli e le altre eventuali fonti di pericolo.

Caesar tactile floors features structured surfaces which can be distinctly perceived in order to allow partially sighted and blind persons to find their way and alert them to obstacles and other sources of danger.

Les sols tactiles de Caesar sont constitués de surfaces avec des reliefs perceptibles au passage, de sorte que les aveugles et les malvoyants puissent s'orienter et reconnaître clairement les obstacles et toute autre source de danger.

Die taktilen Bodenbeläge von Caesar bestehen aus Oberflächen mit beim Begehen spürbaren Reliefmarkierungen. Diese helfen Blinden und Sehbehinderten bei der Orientierung und bei der Erkennung von Hindernissen und anderen, eventuellen Gefahrenquellen.

Тактильная напольная плитка Caesar имеет поверхность с формой рифления, которую распознают стопами ног, и которая позволяет незрячим и слабовидящим людям ориентироваться в пространстве и точно распознавать препятствия и другие источники.













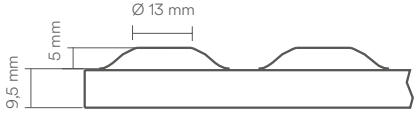
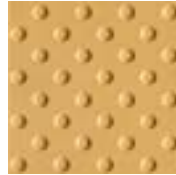

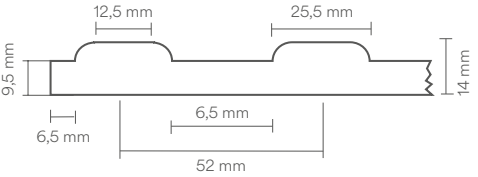



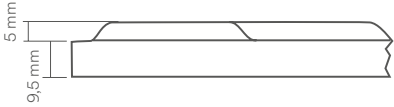



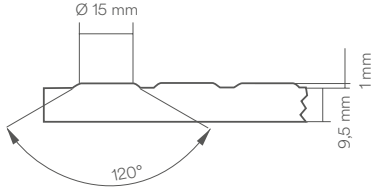

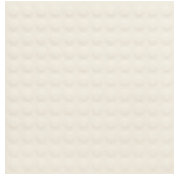
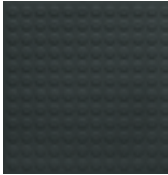
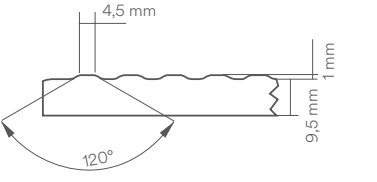

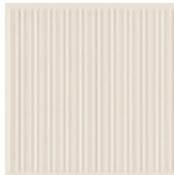
Info
Resources
Tools

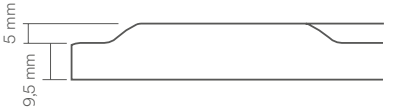

Floor: SAFETY ALT, GO, CROSS, MIX, TURN, LINE YELLOW 30x30
Wall: AUTORE RIVOLI 60x60 MATT RT

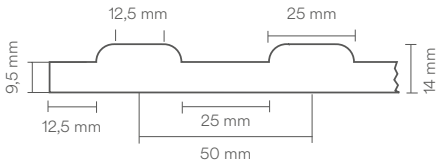





Colori - Formati

Colors - Sizes

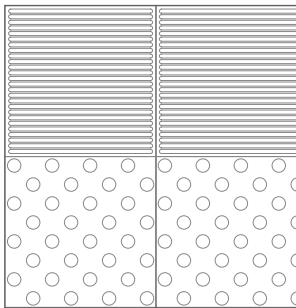
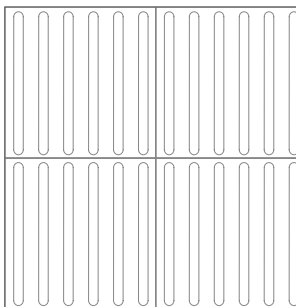
| |
|-------------------------------------------------------------------------------------------------------------------------------------------------------------------------------------------------------------------------------------------------------------------------------------------------------------------------------------------------------------------------|
| <p>ALT</p>     |
| <p>GO</p>     |
| <p>TURN</p>     |
| <p>CROSS</p>     |
| <p>LINE</p>     |
| <p>MIX</p>     |
| <p>STOP</p>     |

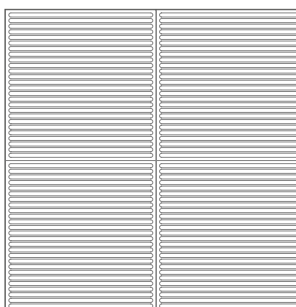
I moduli safety

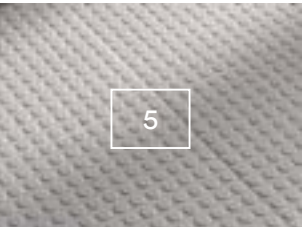
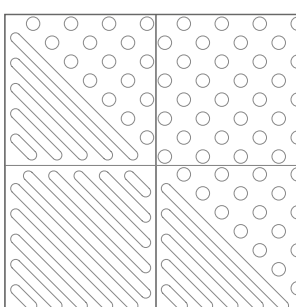
Modules - Modules - Module - модули

| | |
|---------------------------------------------------------------------------------------|------------------------------------------------------------------------------------------------------------------------------------------------------------------------------------------------------------------------------------------------------------------------------------------------------------------------------------------------------------------------------------------------------------------------------------------------------------------------------------------------------------------------------------------------------------------------------------------------------------------------------------------------------------------------------------------------------------------------------------------------------------------------------------------------------------------------------------------------------------------------------------------------------------------------------------------------------------------------------------------------------------------------------------------------------------------------------------------------------------------------------------------------------------------------------------------------------------------------------------------------------------------------------------------------------------------------------------------------------------------------------------|
|  | <p>Pericolo invalicabile Uncrossable Potential Danger - Danger Infranchissable - Potentiell Unüberwindbare Gefahren Непреодолимое Препятствие</p>  <p>Composto da calotte semisferiche sfalsate (moduli "ALT"), in modo da intercettare in ogni situazione il bastone. Va posto in presenza di pericoli, quali ad esempio il bordo di una banchina ferroviaria.</p> <p>Made up of semi-spherical staggered segments ("ALT" modules) that can be identified using the white stick. This system must be placed where there are potential un-crossable dangers, such as, for example, the edge of railway platform.</p> <p>Composé de plots décalés (modules « ALT ») de façon à être heurtés par la canne en toute situation. Il doit être placé pour signaler des dangers comme le bord d'un quai de chemin de fer.</p> <p>Bestehend aus versetzten, halbkugelförmigen Noppen ("ALT" Module), so dass die Information mit dem Blindenstock "gelesen" werden kann. Weist auf Gefahrenbereiche hin wie z.B. das Ende von Bahnsteigen.</p> <p>Форма рифления с расположенными в шахматном порядке полусферическими рифами (модули "ALT"), которые легко ощущаются тростью. Плитка укладывается вблизи опасных зон или препятствий, таких как, например, край привокзального перрона.</p> |
|  | <p>Pericolo valicabile Crossable potential danger - Danger franchissable - Überwindbare gefahren - Преодолимое препятствие</p>  <p>Composto dall'abbinamento dei moduli "ALT" e "LINE", serve ad indicare pericoli valicabili, quali scale o attraversamenti pedonali.</p> <p>Made up of "ALT" and "LINE" modules, used to indicate crossable dangers such as stairs of pedestrian paths.</p> <p>Composé d'un mix de modules « ALT » et « LINE » pour indiquer des dangers franchissables comme un escalier ou un passage pour piétons.</p> <p>Bestehend aus der Verbindung von "ALT" und "LINE" Modulen, die dazu dienen überwindbare Gefahren, wie Treppen oder Fußgängerüberweg anzuzeigen.</p> <p>Сочетание модулей "ALT" и "LINE" указывает на преодолимые препятствия, такие как, например, лестницы или пешеходные переходы.</p> |
|  | <p>Direzione rettilinea Straight direction - Direction rectiligne - Leitrillen - Прямолинейное Направление движения</p>  <p>Composto da strisce rettilinee a rilievo poste sulla superficie (moduli "GO"), che vengono utilizzate per indicare attraverso il senso tattile plantare la direzione da seguire.</p> <p>Made of straight stripes in relief on the surface ("GO" modules) that are used to show the path via the tactile sense of the foot.</p> <p>Composé de bandes rectilignes en relief placées sur la surface (modules « GO ») pour une indication podotactile de la direction à suivre.</p> <p>Bestehend aus geraden, erhabenen Rillen auf der Bodenoberfläche ("GO" Module), die die Richtung angeben und durch den Tastsinn des Fußes zu erkennen sind.</p> <p>Форма рифления с прямыми продольными рифами (модули "GO"), которые легко осязаются стопами ног и указывают направление движения.</p> |
|  | <p>Indicazione di servizio Service - Points remarquables - Service hinweis - Указатель услуг</p>  <p>Composto da una serie di strisce sottili a rilievo (moduli "LINE"), tra loro parallele, indica che bisogna prestare attenzione, ad esempio perché in prossimità del percorso sono presenti mappe tattili, telefoni, toilette, etc.</p> <p>Made up of slim parallel stripes in relief ("LINE" modules) and used to show the presence of useful services such as tactile maps, telephones, toilets, etc.</p> <p>Composé d'une série de fines bandes parallèles en relief (modules « LINE ») qui éveillent l'attention à proximité de points remarquables situés sur le parcours et qui peuvent indiquer la présence de plans tactiles, de téléphones, de toilettes, etc.</p> <p>Bestehend aus einer Reihe dünner, paralleler, erhabener Rillen ("LINE" Modul), die auf das Vorhandensein von Tastkarten, Telefonen, Toiletten etc. in nächster Nähe hinweisen.</p> <p>Форма рифления с рядом тонких параллельных рифов (модули "LINE"). Плитка указывает, что поблизости находятся, например, тактильные карты, телефоны, туалеты и т.д.</p> |
|  | <p>Incrocio Crossroads - Croisement - Kreuzung - Перекрёсток</p>  <p>Composto da calotte semisferiche allineate a testa piatta (moduli "CROSS"), viene utilizzato in presenza di incroci.</p> <p>Made up of semi-spherical, flat and aligned segments ("CROSS" modules) and used at crossroads.</p> <p>Composé de plots alignés à tête plate (modules « CROSS »), il est utilisé pour signaler des croisements.</p> <p>Bestehend aus flach nebeneinander liegenden, halbkugelförmigen Noppen ("CROSS" Module), wird bei Kreuzungen verwendet.</p> <p>Форма рифления с полусферическими рифами, расположенными по прямой линии, с плоской головкой (модули "CROSS"). Плитка укладывается на перекрёстках.</p> |
|  | <p>Svolta a L "L" turn - Virage à 90° - "L" Abbiegung - L-образный поворот</p>  <p>Composto da calotte semisferiche sfalsate e da strisce diagonali a rilievo (moduli "TURN", "ALT" e "MIX"), viene utilizzato per dare continuità al percorso in presenza di curve.</p> <p>Made up of semi-spherical staggered segments and diagonal stripes in relief ("TURN", "ALT" and "MIX" modules) and used to give continuity to the path where there is a street corner in the vicinity.</p> <p>Composé de plots décalés et de bandes diagonales en relief (modules « TURN », « ALT » et « MIX »), il s'utilise pour indiquer la continuité d'un parcours présentant des virages.</p> <p>Bestehend aus versetzten, halbkugelförmigen Noppen und diagonalen, erhabenen Rillen ("TURN", "ALT" und "MIX" Module), wird verwendet, um dem Streckenverlauf bei Abbiegungen und Kurven Kontinuität zu verleihen.</p> <p>Форма рифления с полусферическими рифами, расположенными по прямой линии, с плоской головкой (модули "TURN", "ALT" и "MIX"). Плитка укладывается на месте поворота по пути следования.</p> |

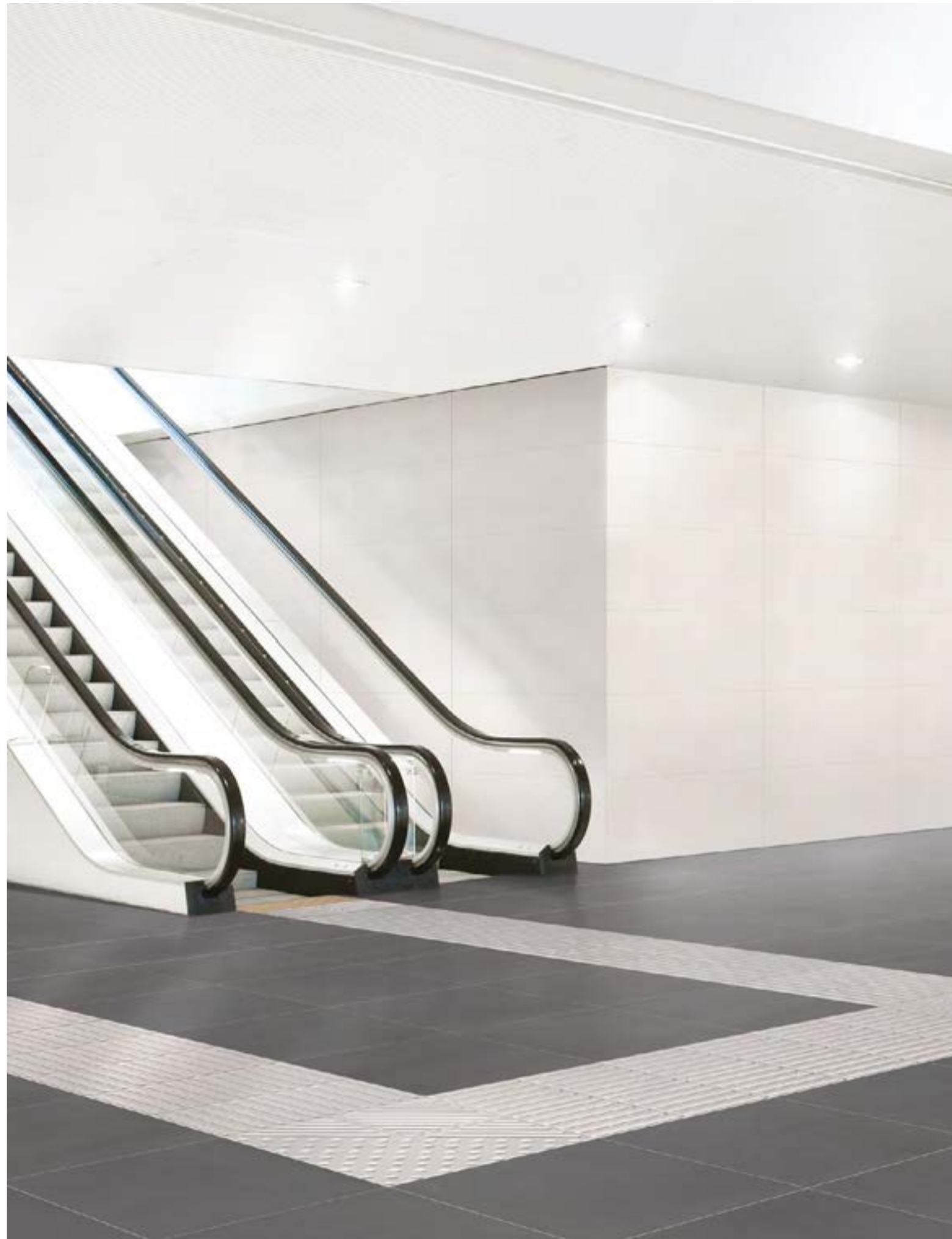

CARATTERISTICHE TECNICHE

TILE PERFORMANCE DATA - NOTES TECHNIQUES - TECHNISCHE AUSKÜNFTE - ТЕХНИЧЕСКАЯ ХАРАКТЕРИСТИКА

Classificazione secondo EN ISO 14411 ISO 13006 annesso G gruppo Bla con Ev ≤0,5% - Classification in accordance with EN ISO 14411 ISO 13006 annex G standards Bla with Ev ≤ 0,5% - Classification selon EN ISO 14411 ISO 13006 annexe G groupe Bla avec Ev ≤0,5% - Klassifizierung gemäß EN ISO 14411 ISO 13006 anlage G Gruppe Bla mit Ev ≤0,5% - Классификация в соответствии с EN ISO 14411 ISO 13006, приложение G, стандарт Bla, где Ev ≤0,5%

| | CARATTERISTICA TECNICA - TECHNICAL CHARACTERISTIC CARACTERISTIQUE TECHNIQUE - TECHNISCHE DATEN ТЕХНИЧЕСКАЯ ХАРАКТЕРИСТИКА | NORMA - NORMS NORME - NORM НОРМА | VALORE * MEDIO "CAESAR" AVERAGE "CAESAR" VALUE * VALEUR * MOYEN "CAESAR" "CAESAR" DURCHSCHNITTSWERT * СРЕДНЕЕ ЗНАЧЕНИЕ "CAESAR" * |
|--|-------------------------------------------------------------------------------------------------------------------------------------------------------------------------------------------------------------------------------------|----------------------------------------|-----------------------------------------------------------------------------------------------------------------------------------------------|
| | Dimensione - Size Dimension - Abmessungen - Размер | ISO 10545-2 | Conforme - In accordance Conforme - Erfüllt - Соответствует |
| | Assorbimento d'acqua* - Water absorption* Absorption d'eau* - Wasseraufnahme* - % Поглощения воды* | ISO 10545-3 | ≤ 0,1% |
| | Resistenza alla flessione* - Bending strength* Résistance à la flexion* - Biegezugfestigkeit* - Упругость* | ISO 10545-4 | Conforme - In accordance Conforme - Erfüllt - Соответствует |
| | Resistenza all'abrasione profonda* - Deep scratch resistance* Résistance à l'abrasion profonde* - Widerstand gegen Tiefenverschleiß* Устойчивость к глубокому истиранию* | ISO 10545-6 | Conforme - In accordance Conforme - Erfüllt - Соответствует |
| | Coefficiente di dilatazione termica lineare* - Thermal linear expansion coefficient* Coefficient de dilatation thermique linéaire* - Koeffizient der linearen thermischen Dehnung* - Коэффициент линейного теплового расширения* | ISO 10545-8 | ≈ 7 (10 ⁻⁶ °C ⁻¹) |
| | Resistenza agli sbalzi termici* - Thermal shock resistance* Résistance aux écarts de température* - Temperaturwechsel Beständigkeit* Устойчивость к тепловому перепаду* | ISO 10545-9 | Resistente - Resistant Résistante - Beständig - Стойкий |
| | Dilatazione all'umidità* - Expansion in humidity* Dilatation à l'humidité* - Feuchtigkeitsausdehnung* Расширение в условиях влажности* | ISO 10545-10 | ≤ 0,1 (mm/m) |
| | Resistenza al gelo* - Frost resistance* Résistance au gel* - Frostbeständigkeit* - Морозоустойчивость* | ISO 10545-12 | Resistente - Resistant Résistante - Beständig - Стойкий |
| | Resistenza all'attacco chimico • - Resistance to chemical attack • Résistance à l'attaque chimique • - Beständigkeit gegen Chemikalien • Устойчивость к химическому воздействию • | ISO 10545-13 | Resistente - Resistant Résistante - Beständig - Стойкий |
| | Resistenza alle macchie* - Resistance to stains* Résistance aux taches* - Fleckenbeständigkeit* Устойчивость к образованию пятен* | ISO 10545-14 | Pulibile - Cleanable Nettoyable - Leicht zu reinigen Чистящийся |

* Valori medi riferiti agli ultimi due anni di produzione e relativi alla finitura naturale del prodotto - Average values referred to the last two years of production and related to the matt finish of the product - Valeurs moyennes des deux dernières années de production et relatifs à la finition naturelle du produit - Durchschnittswerte, die sich auf die letzten zwei Produktionsjahre beziehen und auf die matte Oberfläche - Средние значения относятся к последним двум годам производства и натуральной отделке поверхности

• Per prodotti chimici di uso domestico e additivi per piscina. - For domestic chemicals and swimming pool additives. - Pour produits chimiques à usage domestique et additifs pour piscines. - Für chemische Produkte für den Hausgebrauch und Schwimmbadzusätze. - Для бытовых химикатов и добавок для бассейнов.

Le tonalità dei campioni sono da considerarsi puramente indicative. - Tones of samples are indicative. - Les tonalités des échantillons sont purement indicatives. - Die Farbtöne der Muster sind als rein indicativ zu betrachten. - Тона образцов ориентировочные.

Dettagli tecnici

Technical Details . Détails techniques
Technischeangaben · Технические детали



Finishes - Finitions - Oberflächen - Отделки

La migliore risposta per le tue esigenze. Sempre.

The best answer to your needs. Always. - La meilleure réponse à vos exigences. Toujours.

Die beste Antwort auf Ihren Bedarf. In jedem Fall. - Лучшие ответ на ваши потребности. Всегда.



Matt

Al tatto morbida e delicata, si realizza durante il processo di produzione; solitamente liscia o con leggeri movimenti della superficie.

Soft and delicate to touch, it is achieved during the production process; usually smooth or with slight movements across the surface.

Douce et délicate au toucher, elle naît pendant le processus de production ; généralement lisse ou avec de légers mouvements de la surface.

Wird während des Herstellungsprozesses erzeugt, fühlt sich weich und zart an. In der Regel glatt oder ganz leicht unduliert.

Мягкая, как правило гладкая или слегка шероховатая, на ощупь поверхность обусловлена процессом производства плитки.

Matt R10 B

Superficie opaca in linea con i trend attuali, grazie al coefficiente antiscivolo R10 B, è in grado di coniugare prestazione e valore estetico.

A matte surface in line with current trends. Thanks to its R10 B slip resistance, it combines performance with aesthetic value.

Surface mate selon la tendance actuelle, dont le coefficient antidérapant R10 B permet d'associer performances et valeur esthétique.

Matte Oberfläche im aktuellen Trend. Vereint dank der Rutschfestigkeitsklasse R10 B Leistung und optischen Wert.

Матовая поверхность отвечает актуальным тенденциям. Благодаря коэффициенту стойкости к скольжению R10 B, сочетает в себе прекрасные эксплуатационные характеристики и эстетическую ценность.

Soft

Una superficie innovativa per la delicata sensazione tattile. L'aspetto morbido le conferisce un tratto inedito, nobilitando l'ambiente ove è inserita.

An innovative surface for the delicate tactile sensation. The smooth appearance conveys a new look capable of enhancing the environment.

Une surface innovante pour une sensation tactile délicate et veloutée. Son aspect doux lui confère une caractéristique inédite, enrichissant l'environnement où elle est insérée.

Eine innovative Oberfläche, die sich besonders angenehm anfühlt. Das innovative, weiche Aussehen schenkt jedem Ambiente eine edle Note.

Иновационная поверхность с неповторимыми тактильными ощущениями. Кажущаяся мягкость накладывает отпечаток нетронутости и при использовании способна облагородить любое помещение.

Silk

Il perfetto compromesso tra la lucentezza del lucido e la matericità del Matt. Una superficie morbida e setosa al tatto.

The perfect compromise between the gleam of glossy finish and the texture of Matte finish. A silky-smooth, soft surface.

Le compromis parfait entre l'éclat du brillant et la matérialité du mat. Une surface douce et soyeuse au toucher.

Der perfekte Kompromiss zwischen dem Hochglanz von Lucido und dem stofflichen Matt. Eine weiche Oberfläche, die sich seidig anfühlt.

Идеальный компромисс между блеском глянца и текстурностью матового покрытия. Мягкая и шелковистая поверхность на ощупь.

Lappato

Lappatura tradizionale: è una lavorazione meccanica che consente di ottenere superfici morbide e gradevoli al tatto, in alcuni casi anche brillanti.

Traditional honing: this mechanical processing generates soft surfaces that are pleasant to touch, and in some cases even shiny.

Polissage traditionnel : c'est un usinage mécanique qui permet d'obtenir des surfaces douces et agréables au toucher, voire brillantes dans certains cas.

Traditionelle Läppung: Eine mechanische Bearbeitung, die angenehm weiche, in einigen Fällen auch glänzende Oberflächen erzeugt.

Традиционная лапатированная отделка представляет собой механический процесс, позволяющий придать плитке мягкую приятную на ощупь поверхность, в некоторых случаях блестящую.

Lucidato

Con la sua superficie brillante e lucida a specchio è la finitura più pregiata. Questa finitura consente di enfatizzare la ricchezza grafica del materiale attraverso una superficie dall'aspetto vetroso, luminoso e pulito. Viene realizzata meccanicamente attraverso una lappatura ottenuta con spazzole speciali.

With its gleaming and glossy mirrored surface, this is the most prized finish of all. This finish makes it possible to emphasise the graphic wealth of the material through a surface with a glassy, bright and clean appearance. It is achieved mechanically through honing carried out with special brushes.

Avec sa surface brillante et son effet miroir, c'est la finition la plus luxueuse. Cette finition permet de souligner la richesse graphique du matériau à travers une surface à l'aspect vitreux, lumineux et épuré. Elle est réalisée mécaniquement grâce à un polissage avec des brosses spéciales.

Mit seinem spiegelblanken Hochglanz die prestigevollste Oberfläche. Sie unterstreicht den grafischen Reichtum des Materials durch eine glasähnliche, leuchtende und klare Oberfläche. Wird mechanisch durch Läppen mit Spezialbürsten erzielt.

Блестящая зеркальная поверхность делает эту отделку наиболее изысканной. Эта отделка позволяет подчеркнуть графическое богатство материала за счет блестящей, светлой и чистой поверхности. Отделка выполняется механическим способом с помощью процесса лапатирования специальными щетками.

Finishes - Finitions - Oberflächen - Отделки

La migliore risposta per le tue esigenze. Sempre.

The best answer to your needs. Always. - La meilleure réponse à vos exigences. Toujours.

Die beste Antwort auf Ihren Bedarf. In jedem Fall. - Лучшие ответ на ваши потребности. Всегда.



Craft

Si caratterizza per un particolare effetto 3D che si ispira alle lavorazioni ottenute dall'utilizzo dello scalpello; impiegabile in interno ed esterno, grazie alle qualità tecniche tipiche del grès porcellanato.

It stands out for the special 3D effect which draws its inspiration from the processing obtained using a scalpel; designed for both indoor and outdoor use, thanks to the typical technical qualities of porcelain tiles.

Il se caractérise par un effet 3D particulier qui s'inspire des façonnages obtenus au scalpel ; utilisable aussi bien en intérieur qu'en extérieur, grâce aux qualités techniques typiques du grès cérame.

Zeichnet sich durch einen besonderen 3D-Effekt aus, der an gemeißelte Werke erinnert. Kann dank der hervorragenden technischen Eigenschaften des Feinsteinzeugs innen und außen verlegt werden.

Эту плитку характеризует необычный 3D-эффект, который напоминает результат работы резцом. Ее можно укладывать как в помещении, так и на улице, благодаря техническим характеристикам керамогранита.

Stripes

Un leggero effetto rigato tridimensionale che, nella sua semplicità, contribuisce a personalizzare con eleganza e sobrietà le pareti che riveste, in interno o in esterno.

A light three-dimensional striped look which, in its simplicity, contributes to personalising the walls it clads with elegance and understated appeal, both indoors and outdoors.

Un léger effet rayé tridimensionnel qui, dans sa simplicité, contribue à personnaliser avec élégance et sobriété les murs qu'il revêt, en intérieur ou en extérieur.

Ein leichter, dreidimensionaler Streifen-Effekt, dessen Schlichtheit dazu beiträgt, die Wände mit nüchternen Eleganz zu prägen, innen wie außen.

Легкая трехмерная полоска, несмотря на свою простоту, станет элегантным украшением любых стен как в помещении, так и на улице.

Grip

Ottenuta con l'utilizzo di particolari graniglie sulla superficie, presenta lo stesso aspetto della finitura matt ma con coefficiente antiscivolo R11C, per utilizzo nella pavimentazione di esterni o di ambienti che prevedono presenza d'acqua.

Achieved by applying special grits to its surface, it has the same appearance as the matte finishing but with a slip resistance of R11 C. Ideal for use as outdoor flooring or in spaces where water may be present.

Obtenu par l'utilisation d'une grenaille particulière sur la surface, elle présente le même aspect que la finition mat mais avec un coefficient antidérapant R11C, ce qui permet de l'utiliser pour les sols extérieurs ou les environnements qui prévoient la présence d'eau.

Hergestellt unter Zusatz besonderer Körner auf der Oberfläche. Gleiche Optik wie die matte Ausführung, jedoch mit Rutschfestigkeitsklasse R11C für den Einsatz als Außenboden oder in Räumen, in denen der Boden nass sein kann.

Полученная с помощью специальной гранулы, нанесенной на поверхность, имеет матовый вид, однако, коэффициент стойкости к скольжению составляет R11C, для использования для наружных работ или для укладки в помещениях, в которых подразумевается присутствие воды.

Textured

Caratterizzata da una struttura che garantisce un coefficiente antiscivolo R11C, è ideale per dare forma a soluzioni in continuità con le pavimentazioni indoor o per pavimentazioni esterne. Si realizza durante il processo di produzione; non liscia, ma con asperità superficiali.

Characterised by a structure that guarantees R11C slip resistance, it is ideal for creating solutions that are in keeping with indoor floor tiling or outdoor flooring solutions. It is achieved during the production process; not smooth, but with surface roughness.

Caractérisée par une structure qui garantit un coefficient antidérapant R11C, elle est idéale pour créer des solutions en continuité avec les revêtements de sol intérieurs ou pour des revêtements de sol extérieurs. Elle naît pendant le processus de production ; non lisse mais avec des aspérités superficielles.

Mit einer Struktur, die die Rutschfestigkeitsklasse R11C garantiert. Ideal für optisch einheitliche Innenböden oder für das Outdoor. Während des Herstellungsprozesses erzeugt, nicht glatt, sondern mit unebener Oberfläche.

Характеризуется текстурой, обеспечивающей коэффициент стойкости к скольжению R11C. Отделка идеально подходит для придания формы решениям с эффектом непрерывности внутренней и наружной напольной плитки. Отделка выполняется в процессе производства. Поверхность не гладкая, а слегка шероховатая.

Textured Aextra20

Caratterizzata da una struttura che garantisce un coefficiente antiscivolo R11C e dallo spessore 20mm, è ideale per dare forma a soluzioni per pavimentazioni esterne.

Characterised by a structure that guarantees R11 slip resistance and a thickness of 20mm, it is ideal for creating outdoor flooring solutions.

Caractérisée par une structure garantissant un coefficient antidérapant R11C et par une épaisseur de 20 mm, elle est idéale pour créer des solutions pour les revêtements extérieurs.

Mit einer Struktur, die die Rutschfestigkeitsklasse R11C garantiert, und 20 mm Stärke. Ideal für Außenböden.

Характеризуется текстурой, обеспечивающей коэффициент стойкости к скольжению R11C, и толщиной 20 мм, благодаря чему является идеальным решением для наружных напольных покрытий.

Informazioni estetiche

Aesthetic Information - Informations Esthétiques
Informationen zur Optik - Эстетические Характеристики

La classificazione estetica (Norma ANSI A 137.1 2012 versione 1) definisce i criteri secondo i quali un articolo di una collezione di piastrelle può essere considerato di tono uniforme o meno in base a 5 classi di appartenenza. È importante sottolineare che tale normativa non considera solo le variazioni di colore (tono) tra piastrella e piastrella, ma anche le variazioni della struttura tra pezzo e pezzo; non tiene invece in considerazione le variazioni di grafica (disegno). I valori di stonizzazione V attribuiti ai prodotti risentono di un certo grado di soggettività per cui non si può considerare una vera e propria standardizzazione.

The aesthetic classification (ANSI A 137.1 2012 standard version 1) defines the criteria according to which an individual ceramic tile/product that forms part of a ceramic tile collection can have a uniform shade depending on 5 grades. It is important to underline that this standard does not only refer to colour variations (shade) between tiles but also to the texture variations between ceramic pieces; the standard does not take into consideration the graphic variation (design). The V colour shading values that classify products can be

slightly subjective so should not be considered as a true method of standardization.

La classification esthétique (Norme ANSI A 137.1 2012 version 1) définit les critères selon lesquels un élément d'une collection de carreaux peut être considéré de tonalité uniforme ou non, selon 5 classes d'appartenance. Il est important de souligner que cette norme ne considère pas seulement les changements de couleur (tonalité) d'un carreau à l'autre, mais aussi les variations de la structure d'une pièce à l'autre; en revanche, elle ne prend pas en compte les changements de graphisme (dessin). Les valeurs de dénuancement V attribuées aux produits résultent d'un certain degré de subjectivité c'est pourquoi une véritable normalisation ne peut être considérée.

Die optische Klassifizierung (Norm ANSI A 137.1 2012 Version 1) definiert die Kriterien, denen zufolge die Brandfarbe eines Artikel einer Fliesenkollektion auf der Grundlage von 5 Zugehörigkeitsklassen als einheitlich oder uneinheitlich zu betrachten ist. Dabei ist zu beachten, dass diese Norm nicht nur die Farbvariationen (Farbton) zwischen

den einzelnen Fliesen berücksichtigt, sondern auch Abweichungen in der Oberflächenstruktur; grafische Unterschiede bleiben hingegen unberücksichtigt. Die den Produkten zugewiesenen Farbdifferenzwerte V unterstehen jedoch in einem gewissen Grad der Subjektivität. Daher kann diese Klassifizierung nicht als eine Standardisierung in engsten Sinne betrachtet werden.

В основу классификации по внешним признакам (Стандарт ANSI A 137.1 2012, версия 1) положен ряд критериев, по которым определенный артикул коллекции керамической плитки, относят к одному из 5 классов цветовой и поверхностной неоднородности. Важно подчеркнуть, что стандарт принимает во внимание различия плиток не только по цвету (тону), но и по поверхностной структуре; в то же время стандарт не учитывает различия плиток по рисунку поверхности. Отнесение изделий к определенному классу цветовой неоднородности (значение V) довольно субъективно, поэтому в данном случае нельзя говорить о стандартизации как таковой.

Decori a mosaico e a listelli

Mosaics and listel decorations - Motifs mosaïque et listels
Mosaik- und Leistendekore - Декоры в виде мозаики и бордюров

TECHNICAL DETAILS

COMPOSIZIONE F
30x30 cm . 11¹³/₁₆"x11¹³/₁₆" LUCIDATO



ANIMA

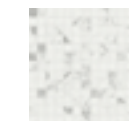

STATUARIO
VENATO



CALACATTA
ORO



BIANCO
ALPINO

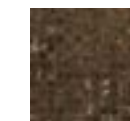

DARK
EMPERADOR



GRAPHITE

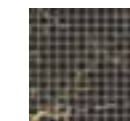

NERO
ATLANTE

ANIMA EVER

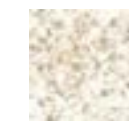

LUXURY
ARABESQUE



APUAN
GOLD

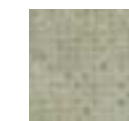

SAGE
GREEN

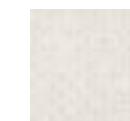

ROYAL
ONYX

ANIMA FUTURA

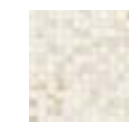

GOLDEN
WHITE



MAJESTIC
WHITE



AMAZING
SILVER

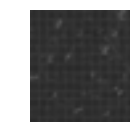

UNIQUE
BLACK

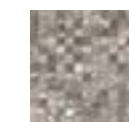

KEEN
GREY



CRYSTAL
DELIGHT



PINK
ONYX

COMPOSIZIONE ESAGONO
28,5X33 cm . 11³/₁₆"x13" LUCIDATO



ANIMA



STATUARIO
VENATO



CALACATTA
ORO



BIANCO
ALPINO



DARK
EMPERADOR



GRAPHITE



NERO
ATLANTE

ANIMA EVER



LUXURY
ARABESQUE



APUAN
GOLD



SAGE
GREEN



ROYAL
ONYX

ANIMA FUTURA



GOLDEN
WHITE



MAJESTIC
WHITE



AMAZING
SILVER



UNIQUE
BLACK



KEEN
GREY





CRYSTAL
DELIGHT



PINK
ONYX

V0  **Aspetto molto uniforme. Stesso tono, molto uniforme**
Extremely uniform aspect. Same shade, uniform.
Aspect très uniforme. Même nuance, très uniforme.
Sehr gleichmäßiges Erscheinungsbild. Gleicher Farbton, sehr gleichmäßig.
Очень однородный вид. Одинаковый, очень однородный тон.

V1  **Aspetto uniforme. Le differenze tra i pezzi sono minime.**
Uniform aspect. Slight shade variations among the pieces.
Aspect uniforme. Les différences entre les pièces sont minimales.
Gleichmäßiges Erscheinungsbild. Minimale Unterschiede der Teile.
Однородный вид. Разница между плитками минимальная.

V2  **Variazioni minime. Le differenze di tono sono distinguibili ma simili.**
Minimum variation. Visible variations but similar shades.
Variations minimales. Les différences de nuance se distinguent mais restent similaires.
Minimale Abweichungen. Die Farbtöne unterscheiden sich zwar, sind sich jedoch ähnlich.
Минимальные различия. Плитки слегка различаются по тону, но очень похожи.

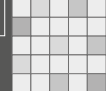
V3  **Variazioni moderate. Differenze di tono significative**
Moderate variation. Significant shade variations.
Variations modérées. Différences de nuance significatives.
Dezente Abweichungen. Deutliche Farbunterschiede
Умеренные различия. Плитки сильно различаются по тону.

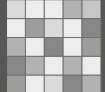
V4  **Variazioni sostanziali. Differenze di tono e struttura molto evidenti.**
Strong variation. Marked shade and texture variations.
Variations substantielles. Différences de nuance et structure très évidentes.
Erhebliche Abweichungen. Sehr deutliche Farb- und Strukturunterschiede.
Сильные различия. Плитки очень сильно различаются по тону и структуре поверхности.

Decori a mosaico e a listelli

Mosaics and listel decorations - Motifs mosaïque et listels
 Mosaik- und Leistendekore - Декоры в виде мозаики и бордюров

COMPOSIZIONE N

30x30 cm . 11¹³/₁₆"x11¹³/₁₆" MATT

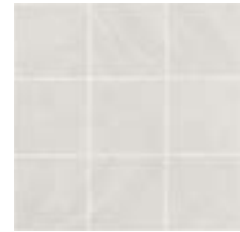

ALCHEMY

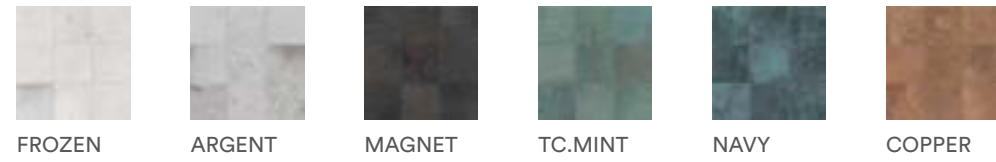

ALCHEMY (BRASS)



ALCHEMY (GLASS)



ANIMA FUTURA (BRASS)

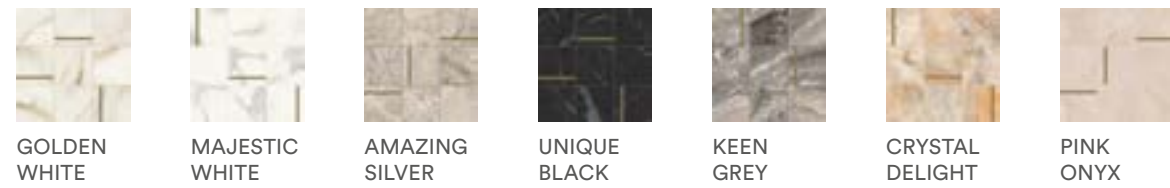

CORE

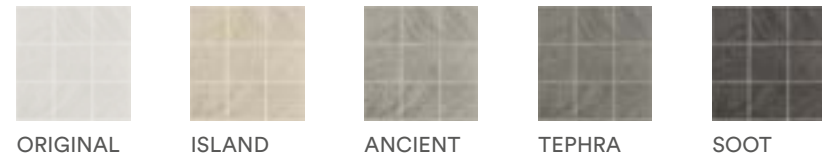

COMPOSIZIONE A

30x30 cm . 11¹³/₁₆"x11¹³/₁₆" MATT



ALCHEMY



WALL MIX

30x60 cm . 11¹³/₁₆"x23⁵/₈" MATT+TEXTURED



PORTRAITS



COMPOSIZIONE M

30x30 cm . 11¹³/₁₆"x11¹³/₁₆" MATT

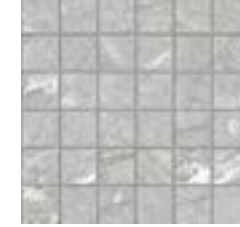

BUILT



CLASH



I.MAT



INNER



KEY_MOOD



PORTRAITS

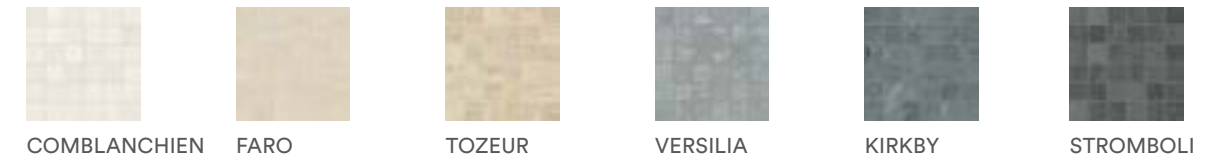

QUARTZ ESSENCE



Decori a mosaico e a listelli

Mosaics and listel decorations - Motifs mosaïque et listels
Mosaik- und Leistendekore - Декоры в виде мозаики и бордюров

TECHNICAL DETAILS

COMPOSIZIONE Q

29x29 cm . 11⁷/₁₆"x11⁷/₁₆" MATT R10 B



PRIMA



CHALK ECRU CONCRETE CLAY LEAD



POWDER AVIO SIENNA

COMPOSIZIONE R

29x29 cm . 11⁷/₁₆"x11⁷/₁₆"

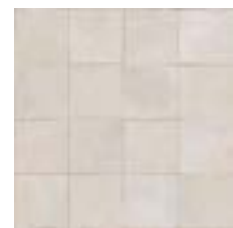

PRIMA MATT R10 B

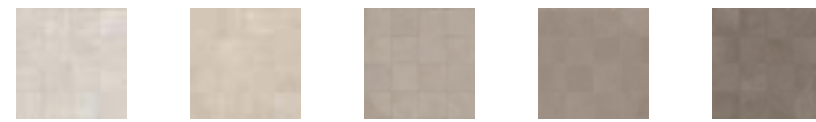

CHALK ECRU CONCRETE CLAY LEAD

PRIMA SOFT

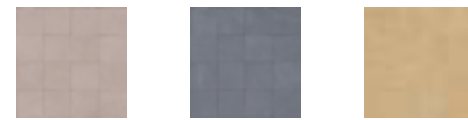

POWDER AVIO SIENNA

COMPOSIZIONE S

29x29 cm . 11⁷/₁₆"x11⁷/₁₆" SOFT



PRIMA



CHALK ECRU CONCRETE CLAY LEAD

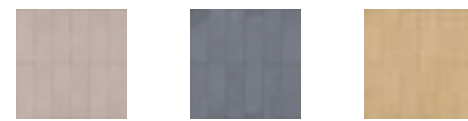

POWDER AVIO SIENNA

COMPOSIZIONE P

29,5x39 cm . 11⁵/₈"x15³/₈" MATT



QUARTZ ESSENCE



FLAKE NEST ROCKY BURNT WILD

ARS

30x30 cm . 11¹³/₁₆"x11¹³/₁₆" MATT



CLASH



SPIRIT SOUL ESSENCE NATURE WISH

CORE



ORIGINAL ISLAND ANCIENT TEPHRA SOOT

TRAMA

30x30 cm . 11¹³/₁₆"x11¹³/₁₆" MATT

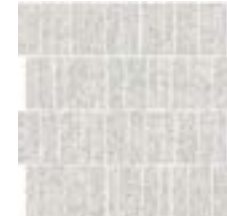

SHAPES OF ITALY



BEOLA REALE ITRIA SESTRIERE IULIA GARDENA

AXIOM

33,5x35 cm . 13³/₈"x13⁵/₈" MATT



I.MAT



RATIO AREA RULE SQUARE CUBE

STILE

22,2x37 cm . 8⁶/₈"x14⁹/₁₆" MATT R10 B



MATERICA



ANTRACITE POLVERE GRIGIO BIANCO CORDA TERRA

Decori a mosaico e a listelli

Mosaics and listel decorations - Motifs mosaïque et listels
 Mosaik- und Leistendekore - Декоры в виде мозаики и бордюров

HEXAGONS

30x30 cm . 11¹³/₁₆"x11¹³/₁₆" MATT



KEY_MOOD



HEXA-STRIPES

38x47 cm . 14¹⁵/₁₆"x18¹/₂" MATT



KEY_MOOD

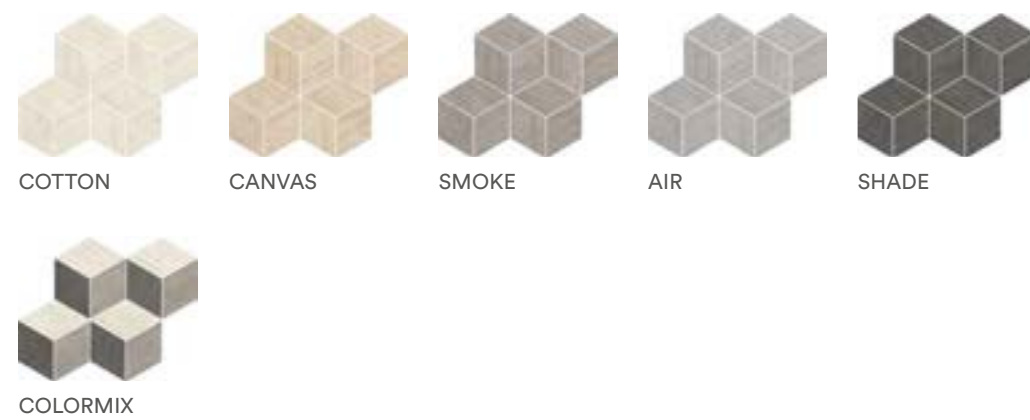

3D HEXAGONS

28x34 cm . 11"x13³/₈" MATT



ALCHEMY



CADENCE

20x120 cm . 7⁷/₈"x47⁷/₈" MATT RT



COCOON



STAVE

30x120 cm . 11¹³/₁₆"x47²/₈" MATT



COCOON



BLISS



JOY



EASE



GLEE



PEACE

LIFE



OAK

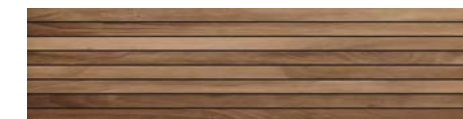

NOCE



NORDIC

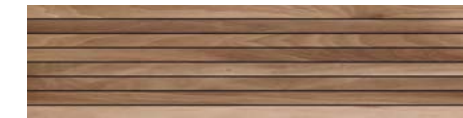

WALNUT

MEET



SCANDI WHITE



ALLURE HAZEL



CHIC BEIGE



ECLECTIC BROWN

STAVE 3D

20x120 cm . 7⁷/₈"x47⁷/₈" MATT

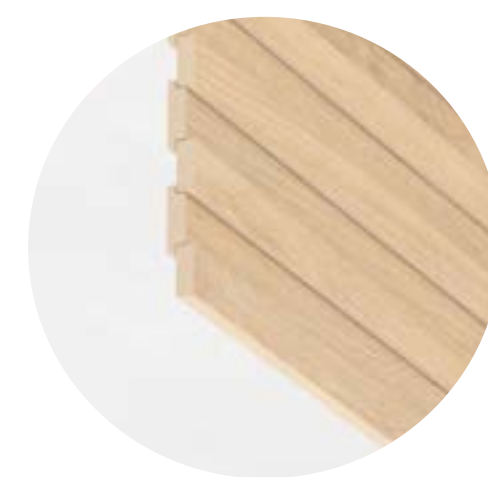

COCOON

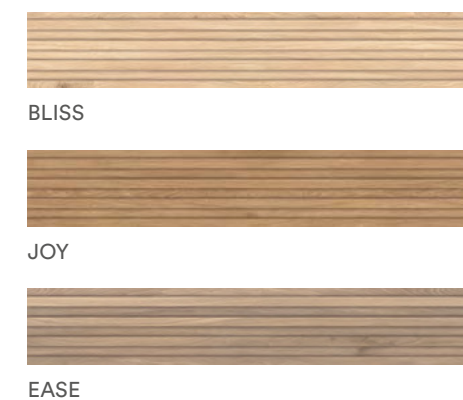

GLEE



PEACE

Altri decori

Other decors - Autres décors
Weitere Dekore - Другие декоры

MEET TARSIA

20x20 cm . 7⁷/₈"x7⁷/₈" MATT RT



ALCHEMY NAVY DECO

20x20 cm . 7⁷/₈"x7⁷/₈" MATT RT

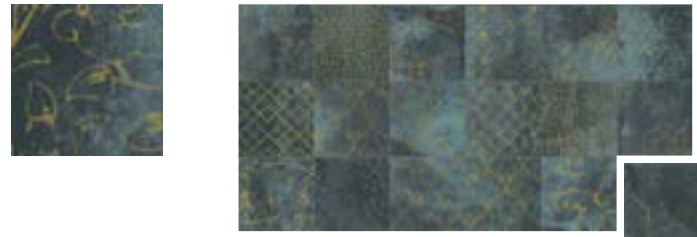

ALCHEMY COPPER DECO

20x20 cm . 7⁷/₈"x7⁷/₈" MATT RT



TC.MINT DECO

30x30 cm . 11¹³/₁₆"x11¹³/₁₆" MATT RT



ALCHEMY

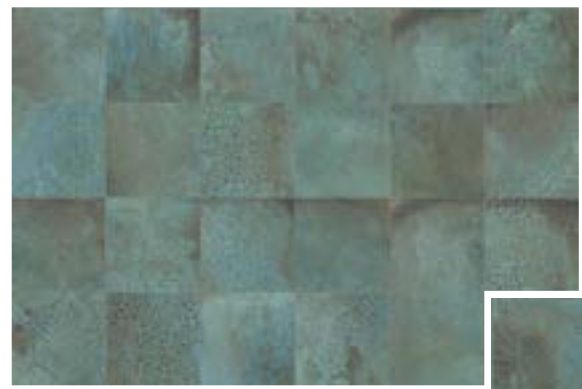

SHAPES OF ITALY VENTAGLIO

53,2x102,8 cm . 20¹⁵/₁₆"x40⁴/₈" TEXTURED



MONVISO



LAVIS

SHAPES OF ITALY STELO OTTONE*

0,5x60 cm . ³/₁₆"x23⁵/₈"

| Decoro - Decor | Dimensione tozzetti o listelli - Size of tesserae or listels |
|----------------------|--------------------------------------------------------------|
| Composizione A 30x30 | 3,5x3,5 cm |
| Composizione F 30x30 | 2,2x2,2 cm |
| Composizione L 30x30 | 5x15 cm |
| Composizione M 30x30 | 4,8x4,8 cm |
| Composizione N 30x30 | 9,8x9,8 cm |
| Composizione Q 29x29 | 14,5x14,5 cm |
| Composizione R 29x29 | 7,25x7,25 cm |
| Composizione S 29x29 | 4,8x14,5 cm |

| Decoro - Decor | Dimensione tozzetti o listelli - Size of tesserae or listels |
|----------------------|--------------------------------------------------------------|
| Stave 30x120 | 3,5x120 cm |
| Composizione Esagono | Lato esagono/Hexagon side 5,2 cm |
| Hexagons | Lato esagono/Hexagon side 8,5 cm |
| 3D Hexagons | Lato esagono/Hexagon side 5,5 cm |

RT Rettificato, squadrato, monocalibro. - Rectified, squared, one caliber. - Rectifié, mis d'équerre et monocalibre. - Rektifiziert, rechtwinkelig und Ein kaliber. - Ректифицированный, одного калибра.

* Solo per rivestimento. - Only for wall application. - Exclusivement pour revêtement mural. - Nur als Wandverkleidung geeignet. - Только для облицовки.

Altri decori

Other decors - Autres décors
Weitere Dekore - Другие декоры

DECO SOLUTIONS

60x120 cm . 23⁵/₈"x47²/₈" MATT RT



FLOWER



LEAF



PEONIA



ROSE

PRIMA

RAMMED 120x278 cm . 47²/₈"x109⁷/₁₆" MATT RT

Range faces



PRIMA

IMPRESSION 120x278 cm . 47²/₈"x109⁷/₁₆" MATT RT

Range faces



PRIMA

GOLD WILLOW 120x278 cm . 47²/₈"x109⁷/₁₆" MATT RT *

Range faces



A

B

Altri decori

Other decors - Autres décors
Weitere Dekore - Другие декоры

TECHNICAL DETAILS

DECO SOLUTIONS

PAMPA 120x278 cm . 47²/₈"x109⁷/₁₆" MATT RT

Range faces



A

B

C

DECO SOLUTIONS

WATERCOLOR 120x278 cm . 47²/₈"x109⁷/₁₆" MATT RT

Range faces



A

B

C

RT Rettificato, squadrato, monocalibro. - Rectified, squared, one caliber. - Rectifié, mis d'équerre et monocalibre. - Rektifiziert, rechtwinkelig und Ein kaliber. - Ректифицированный, одного калибра.

DECO SOLUTIONS

JUNGLE 120x278 cm . 47²/₈"x109⁷/₁₆" MATT RT

Range faces



A

B

ANIMA FUTURA

GOLD MAGNOLIA 120x278 cm . 47²/₈"x109⁷/₁₆" LUCIDATO RT *



DECO SOLUTIONS

SPRING 120x278 cm . 47²/₈"x109⁷/₁₆" MATT RT

Range faces



A

B

* Solo per rivestimento. - Only for wall application. - Exclusivement pour revêtement mural. - Nur als Wandverkleidung geeignet. - Только для облицовки.

Altri decori

Other decors - Autres décors
Weitere Dekore - Другие декоры

JOIN

DECO 120x278 cm . 47²/₈"x109⁷/₁₆" MATT RT *

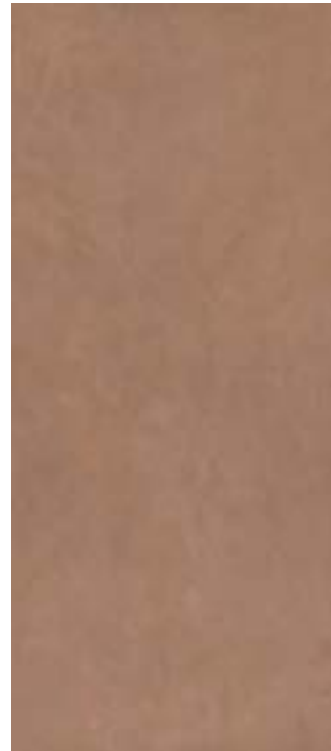

SPICE



VERVE

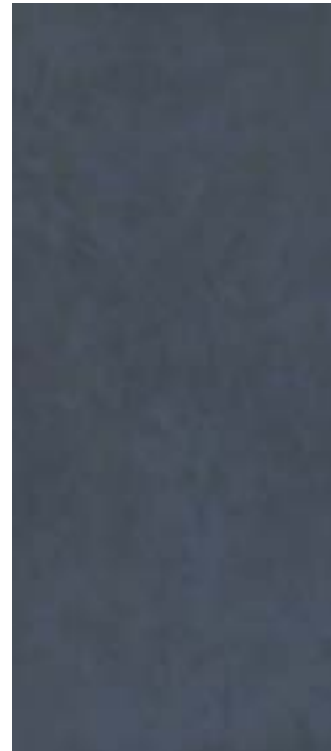

INK

JOIN

REED 120x278 cm . 47²/₈"x109⁷/₁₆" MATT RT *



JOIN

DUSK 120x278 cm . 47²/₈"x109⁷/₁₆" MATT RT *



SPICE



VERVE

JOIN

HOOP 120x278 cm . 47²/₈"x109⁷/₁₆" MATT RT *



A



B

* Solo per rivestimento. - Only for wall application. - Exclusivement pour revêtement mural. - Nur als Wandverkleidung geeignet. - Только для облицовки.

RT Rettificato, squadrato, monocalibro. - Rectified, squared, one caliber. - Rectifié, mis d'équerre et monocalibre. - Rektifiziert, rechtwinkelig und Ein kaliber. - Ректифицированный, одного калибра.

Scalini sagomati

Step treads - Marches Façonnées
Geformte Treppenstufen - Фасонные Ступени

TORO LINEARE ASSEMBLATO

Assembled linear covenosing - Toro linéaire assemblé- Montiert Lineare Bullnose - В Сборе прямой элемент торо

33x60 cm . 13"x23⁵/₈"

Alchemy, Anima, Autore, Built, Clash, Core, Inner, Join, Key_Mood, Portraits, Quartz Essence, Relate Flame, Shapes of Italy

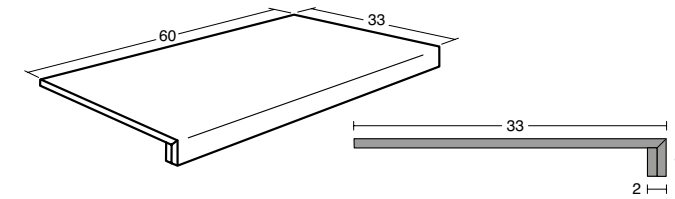

33x80 cm . 13"x31¹/₈"

Alchemy, I.Mat

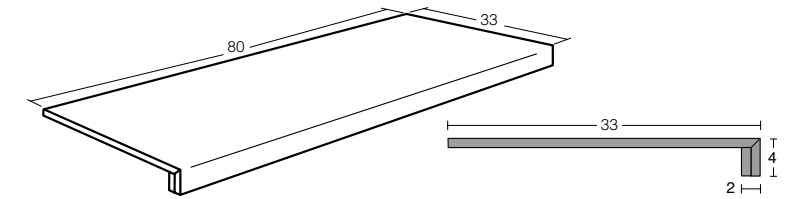

33x120 cm . 13"x47²/₈"

Alchemy, Anima Ever, Anima Futura, Core, Join, Key_Mood, Materica, Portraits, Prima, Quartz Essence, Relate Flame, Shapes of Italy

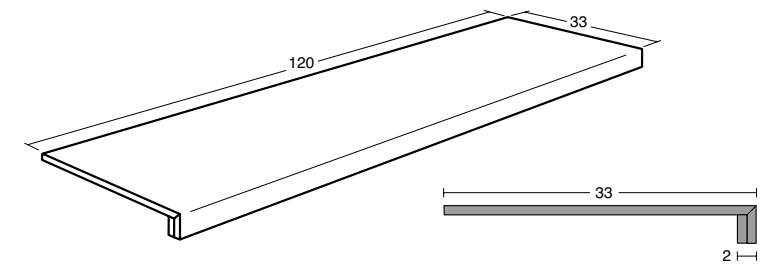

Manuale di posa, uso, pulizia e manutenzione

Laying, use, cleaning and maintenance manual - Manuel de Pose, d’Utilisation, de Nettoyage et d’Entretien

Handbuch zur Verlegung, Verwendung, Reinigung und Pflege - Руководство по укладке, использованию, чистке и уходу

Suggerimenti per posa e manutenzione

Advice for installation and care - Conseils pour la Pose et l’entretien

Empfehlungen für die Verlegung und Pflege - Рекомендации по укладке и уходу

Introduzione - Introduction - Introduction - Vorbemerkung - Введение

Un pavimento è un sistema costituito da più elementi, tra cui il materiale in grès porcellanato, ed affinché il risultato di posa sia soddisfacente è necessario che il massetto di sottofondo e l’installazione del materiale ceramico vengano eseguiti “a regola d’arte”. Come riferimento normativo si consiglia di consultare la norma UNI 11493 che regola la posa di pavimenti e rivestimenti interni ed esterni.

A floor is a system made up of various elements. In order to ensure satisfactory installation, the screed must be made and installation of the ceramic material performed in accordance to the rules of the trade. As reference, we recommend you to consult the UNI 11493 standard that sets forth the rules for installation

Verifica del supporto e del materiale da posare

Checking the substrate and material to install - Contrôle du Support et du Matériel à Poser

Prüfung von Untergrund und Verlegematerial - Проверка основы и укладываемого материала

La verifica e la preparazione del supporto sono il primo passo prima di iniziare la posa; controllare che sia perfettamente planare, che non vi siano fessurazioni, che sia ben pulito e scevro da polvere e/o sostanze grasse. Un’altra verifica estremamente importante è il controllo del materiale da posare: il posatore, prima della posa, essendo l’operatore professionale che realizza la piastrellatura e che per primo “vede” e “manipola” le piastrelle, deve verificare che l’articolo sia quello scelto come colore e formato, verificare il tono, il calibro e la scelta e che non vi siano piastrelle con vizi palesi, e segnalare al committente e al progettista eventuali anomalie. Questa operazione di verifica deve sempre essere fatta in quanto una volta posato il materiale viene considerato accettato e quindi non più contestabile. Ci possono essere casi in cui il massetto di sottofondo sia costituito da un pavimento preesistente; anche in questo caso bisogna avere delle accortezze prima della posa del materiale ceramico in modo da assicurarsi un lavoro realizzato ad opera d’arte. La prima cosa da accertare è che la pavimentazione esistente sia perfettamente incollata al sottofondo e sia priva di crepe; procedere quindi con una profonda pulizia di sgrassaggio per eliminare eventuali residui di cere o prodotti saponati che utilizzati per lungo tempo potrebbero essersi ancorati alla superficie. Tale pulizia deve essere effettuata con una soluzione di acqua e soda caustica o tramite detersivi fortemente alcalini reperibili in commercio. Se invece le condizioni del vecchio pavimento non fossero soddisfacenti, è necessario rimuovere le piastrelle in fase di distacco, riempire eventuali fessure del sottofondo tramite prodotti specifici per quest’uso, colmare le zone in cui mancano le piastrelle tramite rasatura con cemento a presa rapida; valutare insieme al committente e al progettista l’utilizzo di un primer per una migliore

of interior and exterior floor and wall coverings.

Un carrelage est un système composé de plusieurs éléments dont le matériel en grès cérame. Pour que le résultat de la pose soit satisfaisant, il faut que la chape, la sous-couche et l’application du matériel céramique soient effectués selon les règles de l’art. À ce propos, il est conseillé de consulter la norme UNI 11493 qui réglemente la pose de carrelages et de revêtements intérieurs et extérieurs.

Ein Fußboden ist ein System aus mehreren Elementen, darunter das Feinsteinzeugmaterial. Für ein zufriedenstellendes Verlegeresultat müssen der darunterliegende Estrich sowie die Verlegung des

Verifica del supporto e del materiale da posare

Checking the substrate and material to install - Contrôle du Support et du Matériel à Poser

Prüfung von Untergrund und Verlegematerial - Проверка основы и укладываемого материала

adesione al pavimento preesistente. Checking and preparing the substrate are the first steps towards correct installation; make sure that the substrate is perfectly flat, that there are no cracks, that it is clean and that any dust and/or oily substances have been removed. Another essential check is that on the material to install: before installation, the fitter in charge of laying, who actually “sees” the tiles and possesses the necessary expertise to “handle” them, must make sure that the item corresponds to your choice in terms of colour and size; must check the tone, the caliber and quality grade and make sure that there are no visible faults. Such faults must be immediately reported to the purchaser and project engineer. This check must always be performed. After installation, material is deemed to be accepted and no complaint may be lodged. There may be cases in which the substrate in an existing floor; this case also calls for certain preliminary checks to be made before installation so as to guarantee that work is performed in accordance to the rules of the trade. First of all, make sure the existing floor is perfectly and firmly attached to underlying substrate and that there are no cracks; clean thoroughly to remove grease, residues of wax or soapy products that may have stuck to the surface. This cleaning session must be performed using a solution of water and caustic soda, or using strongly alkaline detergents retrievable on the market. If the conditions of the existing floor are not satisfactory, dislodged tiles must be removed. Fill in the cracks with products especially designed for this purpose and gaps with quick-setting cement that must thus be levelled accordingly. Before using a primer, consult the purchaser and project engineer.

Il est nécessaire, avant la pose, de contrôler et

Keramikmaterials fachgerecht ausgeführt werden. Zur Normenlage siehe die Richtlinie UNI 11493 zur Verlegung von Wand- und Bodenbelägen in Innen- und Außenbereichen.

Пол - это система, состоящая из нескольких элементов, в том числе и из керамогранитного материала. Для получения удовлетворительного результата укладки необходимо безупречно залить подстилающую стяжку и уложить керамический материал. В качестве справочно-нормативной документации мы советуем обратиться к стандарту UNI 11493, предписывающему правила по укладке напольной и облицовочной плитки в помещениях и на улице.

Verifica del supporto e del materiale da posare

Checking the substrate and material to install - Contrôle du Support et du Matériel à Poser

Prüfung von Untergrund und Verlegematerial - Проверка основы и укладываемого материала

de préparer le support ; de contrôler qu’il est parfaitement plat, qu’il ne présente aucune fissure, qu’il est bien propre, exempt de poussière et/ou de substances grasses. Il est en outre extrêmement important de contrôler le matériel à poser : le poseur, à savoir l’opérateur professionnel qui réalise le carrelage et qui « voit » et « manipule » en premier les carreaux, doit s’assurer que l’article correspond bien à la couleur et au format choisis ; que le ton et le calibre sont corrects et qu’aucun carreau ne présente de vices apparents. Il devra en outre signaler toute anomalie au client et au designer. Cette opération de contrôle est absolument nécessaire car, une fois posé, le matériel est considéré comme étant accepté et il n’est plus possible de le contester. La pose du matériel céramique sur une chape constituée d’un vieux sol requiert elle aussi quelques contrôles de manière à l’exécuter dans les règles de l’art. Il faut avant s’assurer que le vieux sol est parfaitement collé sur la sous-couche et qu’il ne présente aucune fissure. Il faut ensuite le dégraisser pour éliminer tout résidu de cires ou de produits savonneux qui pourraient, après avoir été longtemps utilisés, être accrochés à la surface. Ce nettoyage doit être effectué avec une solution d’eau et de soude caustique ou bien à l’aide de détergents fortement alcalins disponibles sur le marché. Si les conditions du vieux sol sont par contre douteuses, enlever les carreaux durant la phase de décollement, remplir les éventuelles fissures de la sous-couche par des produits spécialement prévus à cet effet, ragréer les zones dépourvues de carreaux avec du ciment à prise rapide. Il convient également d’évaluer avec le client et le designer l’application d’une couche d’apprêt pour améliorer l’adhérence au vieux sol.

Bevor mit der Verlegung selbst begonnen wird,

ist als erster Schritt der Untergrund zu prüfen und vorzubereiten. Dieser muss perfekt eben, frei von Rissen, sauber und frei von Staub und/ oder fettigen Substanzen sein. Eine weitere, extrem wichtige Prüfung ist jene des zu verlegenden Materials: Der Fliesenleger hat als Experte, der die Fliesen vor der Verlegung als Erster sieht und handhabt, die Aufgabe, diese zu kontrollieren. Es ist zu prüfen, ob Farbe und Format den Wünschen entsprechen, außerdem Farbton, Kaliber und Güteklasse, und dass keine angeschlagenen oder anderweitig schadhaften Fliesen vorhanden sind. Diese Kontrolle muss vor der Verlegung erfolgen, da das Material nach der Verlegung als akzeptiert gilt und nicht mehr beanstandet werden kann. In einigen Fällen erfolgt die Verlegung über einem vorhandenen Bodenbelag; auch in diesem Fall sind vor der Verlegung des Keramikmaterials Kontrollen erforderlich, um eine fachgerechtes Ergebnis zu erzielen. Zunächst ist sicherzustellen, dass der vorhandene Bodenbelag perfekt an seinem Untergrund anhaftet und keine Risse aufweist. Anschließend ist er gründlich zu reinigen und zu entfetten, um eventuelle Spuren von Wachs oder Seifen zu entfernen, die nach häufigem Gebrauch noch an der Oberfläche anhaften könnten. Diese Reinigung ist mit einer Lösung aus Wasser und Ätznatron bzw. mit handelsüblichen, stark alkalischen

Adesivi consigliati

Recommended adhesives - Adhésifs Conseillés

Empfohlene Fliesenkleber - Рекомендуются клеящие вещества

La scelta del collante è importante per la buona riuscita della posa. È quindi necessario utilizzare adesivi di alta qualità indicati per la posa di materiale ceramico. Si consiglia l’impiego di collanti di Classe C2 E o superiore – Normativa EN 12004 . Per la posa a rivestimento si consigliano collanti di classe C2 TE - EN 12004, resistenti allo scivolamento. Per la posa dei grandi formati Project Evolution si consigliano collanti di Classe C2 E S1 oppure S2 - EN 12004. In caso di posa a basse temperature oppure qualora sia necessario mettere in esercizio rapidamente il pavimento o rivestimento ceramico è indicato l’utilizzo di collanti C2 F – EN 12004. Attenzione: l’utilizzo di malta cementizia tradizionale non garantisce un’adeguata adesione del materiale e resistenza nel tempo pertanto se ne sconsiglia l’impiego. Per applicazioni particolari rivolgersi direttamente al produttore di adesivi.

The choice of the right adhesive is important for good installation. It is essential to use top quality adhesives, especially made for installing ceramic materials. We recommend the use of Class C2 E or superior adhesives – EN 12004 standard. For wall tiles, we recommend Class C2 TE - EN 12004 adhesives that are slip resistant. For the big slabs of Project Evolution, we recommend Class C2 E S1 or S2 - EN 12004 adhesives. In the event of installation at low temperatures or if you need to use the ceramic floor or wall in a short time, we recommend the use of C2 F – EN 12004 adhesives. Attention: the use of conventional cement-based

Produkten vorzunehmen. Ist der vorhandene Bodenbelag hingegen nicht in einwandfreiem Zustand, so sind sich ablösende Fliesen zu entfernen, eventuelle Risse im Untergrund mit Spezialprodukten zu füllen und Stellen, in denen Fliesen fehlen, mit schnell abbindendem Zement auszugleichen. Die Anwendung eines Primers als Haftbrücke ist mit dem Bauherrn und dem Planer zu erwägen.

Проверка и подготовка основы - это первые операции, которые необходимо выполнить перед началом укладки. Убедитесь, что основа совершенно ровная, без трещин, совсем чистая и без следов пыли и/или жирных веществ. Очень важную роль играет также контроль укладываемого материала: перед укладкой плиточник, то есть, выполняющий работу мастер, который раньше всех видит плитку и обращается с ней, должен проверить, что цвет и формат артикула совпадают с выбранными, проверить тон, калибр и сорт материала, а также убедиться в отсутствии плитки с явными дефектами, сообщая заказчику и проектировщику о возможных проблемах. Следует обязательно выполнять эту предварительную проверку, потому что после укладки материал считается принятым заказчиком, следовательно, претензии по нему не принимаются. Бывает, что

TECHNICAL DETAILS

in qualità di sottileggiante strato si utilizza come esistente. Anche in questo caso bisogna avere delle accortezze prima della posa del materiale ceramico in modo da assicurarsi un lavoro realizzato ad opera d’arte. La prima cosa da accertare è che la pavimentazione esistente sia perfettamente incollata al sottofondo e sia priva di crepe; procedere quindi con una profonda pulizia di sgrassaggio per eliminare eventuali residui di cere o prodotti saponati che utilizzati per lungo tempo potrebbero essersi ancorati alla superficie. Tale pulizia deve essere effettuata con una soluzione di acqua e soda caustica o tramite detersivi fortemente alcalini reperibili in commercio. Se invece le condizioni del vecchio pavimento non fossero soddisfacenti, è necessario rimuovere le piastrelle in fase di distacco, riempire eventuali fessure del sottofondo tramite prodotti specifici per quest’uso, colmare le zone in cui mancano le piastrelle tramite rasatura con cemento a presa rapida; valutare insieme al committente e al progettista l’utilizzo di un primer per una migliore adesione al pavimento preesistente. Checking and preparing the substrate are the first steps towards correct installation; make sure that the substrate is perfectly flat, that there are no cracks, that it is clean and that any dust and/or oily substances have been removed. Another essential check is that on the material to install: before installation, the fitter in charge of laying, who actually “sees” the tiles and possesses the necessary expertise to “handle” them, must make sure that the item corresponds to your choice in terms of colour and size; must check the tone, the caliber and quality grade and make sure that there are no visible faults. Such faults must be immediately reported to the purchaser and project engineer. This check must always be performed. After installation, material is deemed to be accepted and no complaint may be lodged. There may be cases in which the substrate in an existing floor; this case also calls for certain preliminary checks to be made before installation so as to guarantee that work is performed in accordance to the rules of the trade. First of all, make sure the existing floor is perfectly and firmly attached to underlying substrate and that there are no cracks; clean thoroughly to remove grease, residues of wax or soapy products that may have stuck to the surface. This cleaning session must be performed using a solution of water and caustic soda, or using strongly alkaline detergents retrievable on the market. If the conditions of the existing floor are not satisfactory, dislodged tiles must be removed. Fill in the cracks with products especially designed for this purpose and gaps with quick-setting cement that must thus be levelled accordingly. Before using a primer, consult the purchaser and project engineer.

Adesivi consigliati

Recommended adhesives - Adhésifs Conseillés

Empfohlene Fliesenkleber - Рекомендуются клеящие вещества

mortar does not guarantee sufficient adhesion and resistance over time. Therefore, its use is not recommended. In the event of special applications, contact the adhesive manufacturer directly.

Il est important de bien choisir le mortier-colle pour réussir la pose. Il faut donc utiliser des adhésifs de haute qualité spécialement conçus pour la pose du matériel céramique. Il est conseillé d’utiliser des colles Classe C2 E ou supérieure – Norme EN 12004. Pour le revêtement de parois, il est conseillé d’utiliser des colles Classe C2 TE - EN 12004, qui résistent à la glissance. Pour la pose des grands formats Project Evolution, il est conseillé d’utiliser des colles Classe C2 E S1 ou S2 - EN 12004. En cas de pose à basse température ou pour un carrelage ou revêtement céramique rapidement praticable, il est conseillé d’utiliser des colles C2 F – EN 12004. Attention : il est déconseillé d’utiliser un mortier-colle traditionnel étant donné qu’il ne garantit pas une adhérence adéquate du matériel ni sa résistance dans le temps. En cas d’applications particulières, s’adresser directement au producteur d’adhésifs.

Die Wahl des Klebers ist für das gute Gelingen der Verlegung entscheidend. Verwenden Sie nur hochwertige Fliesenkleber. Wir empfehlen rutschfeste Kleber der Klasse C2 E oder höher nach Richtlinie EN 12004. Für die Verlegung der Wandfliesen empfehlen wir rutschfeste Kleber der Klasse C2 TE - EN 12004. Für die Verlegung der Großformate aus der Serie Project Evolution empfehlen wir Kleber der Klasse C2 E S1 oder S2 - EN 12004. Im Fall der

in qualità di sottileggiante strato si utilizza come esistente. Anche in questo caso bisogna avere delle accortezze prima della posa del materiale ceramico in modo da assicurarsi un lavoro realizzato ad opera d’arte. La prima cosa da accertare è che la pavimentazione esistente sia perfettamente incollata al sottofondo e sia priva di crepe; procedere quindi con una profonda pulizia di sgrassaggio per eliminare eventuali residui di cere o prodotti saponati che utilizzati per lungo tempo potrebbero essersi ancorati alla superficie. Tale pulizia deve essere effettuata con una soluzione di acqua e soda caustica o tramite detersivi fortemente alcalini reperibili in commercio. Se invece le condizioni del vecchio pavimento non fossero soddisfacenti, è necessario rimuovere le piastrelle in fase di distacco, riempire eventuali fessure del sottofondo tramite prodotti specifici per quest’uso, colmare le zone in cui mancano le piastrelle tramite rasatura con cemento a presa rapida; valutare insieme al committente e al progettista l’utilizzo di un primer per una migliore adesione al pavimento preesistente. Checking and preparing the substrate are the first steps towards correct installation; make sure that the substrate is perfectly flat, that there are no cracks, that it is clean and that any dust and/or oily substances have been removed. Another essential check is that on the material to install: before installation, the fitter in charge of laying, who actually “sees” the tiles and possesses the necessary expertise to “handle” them, must make sure that the item corresponds to your choice in terms of colour and size; must check the tone, the caliber and quality grade and make sure that there are no visible faults. Such faults must be immediately reported to the purchaser and project engineer. This check must always be performed. After installation, material is deemed to be accepted and no complaint may be lodged. There may be cases in which the substrate in an existing floor; this case also calls for certain preliminary checks to be made before installation so as to guarantee that work is performed in accordance to the rules of the trade. First of all, make sure the existing floor is perfectly and firmly attached to underlying substrate and that there are no cracks; clean thoroughly to remove grease, residues of wax or soapy products that may have stuck to the surface. This cleaning session must be performed using a solution of water and caustic soda, or using strongly alkaline detergents retrievable on the market. If the conditions of the existing floor are not satisfactory, dislodged tiles must be removed. Fill in the cracks with products especially designed for this purpose and gaps with quick-setting cement that must thus be levelled accordingly. Before using a primer, consult the purchaser and project engineer.

Giunti di dilatazione

Expansion joints - Joints de dilatation

Dehnungsfugen - Расширительные швы

In ogni operazione di piastrellatura è previsto l'inserimento di una serie di giunti di dilatazione in grado di conferire la giusta elasticità finalizzata ad evitare l'insorgere di tensioni che porterebbero al deterioramento della superficie pavimentata. I giunti di dilatazione possono essere realizzati in opera oppure prefabbricati. In ogni caso devono avere una larghezza generalmente compresa tra i 5 e 12 mm. Il disegno dei giunti deve essere realizzato in fase progettuale dal progettista o dal direttore dei lavori, in modo tale da campire una superficie quadrata o rettangolare che presenti un rapporto tra i lati possibilmente inferiore a 1,5. Generalmente le dimensioni in funzione delle destinazioni d'uso sono pari a:

- pavimenti rivestimenti interni, m: 5 x 5 o 6 x 4;
- pavimenti esterni e facciate esterne, m: 3 x 3 o 4 x 2,5.

Per maggiori informazioni sulla creazione e disposizione dei giunti si rimanda alla normativa.

All tiling operations call for the use of expansion joints that give the right elasticity and prevent stress, which could eventually cause damage to the tiled floor. Expansion joints can be provided during installation or can be prefabricated. In any case, their width generally ranges from 5 to 12 mm. The layout of the joints must be established during the design stage by the project engineer or work site supervisor in order to cover a square or rectangular surface with a ratio between sides that is below 1.5.

Depending on the intended use, dimensions are:

- interior walls and floors, m: 5 x 5 or 6 x 4;

- exterior walls and facades, m: 3 x 3 o 4 x 2,5.

For more information on providing and arranging joints, refer to the standard.

La pose d'un carrelage comporte le positionnement d'une série de joints de dilatation en mesure de conférer au sol une élasticité adéquate permettant d'éviter la détérioration des carreaux. Les joints de dilatation peuvent être réalisés sur place ou bien être préfabriqués. Dans les deux cas, leur largeur doit être comprise entre 5 et 12 mm. Le dessin des joints doit être réalisé en phase de conception par le designer ou le directeur des travaux de manière à ce que la surface créée, carrée ou rectangulaire, présente un rapport entre les côtés si possible inférieur à 1,5. Les dimensions en fonction des applications prévues sont généralement les suivantes :

- sols revêtements intérieurs (en m) : 5 x 5 ou 6 x 4 ;

- sols extérieurs et façades extérieures (en m) : 3 x 3 ou 4 x 2,5.

Pour de plus amples informations sur la création et la disposition des joints, consulter la norme spécifique.

Bei jeder Verlegearbeit ist eine Reihe von Dehnungsfugen anzubringen, die für die richtige Elastizität sorgen und so das Entstehen von Spannungen vermeiden, welche den Bodenbelag beschädigen würden. Die Dehnungsfugen können vor Ort ausgeführt oder gebrauchsfertig bezogen werden. Sie sollten in jedem Fall 5 bis 12 mm breit sein. Die Anordnung der Dehnungsfugen ist in der Planungsphase bzw. durch den Bauleiter zu

bestimmen; sie sollten stets quadratische Flächen oder Rechtecke mit einem Seitenverhältnis von möglichst unter 1,5 definieren. In der Regel lauten die Abmessungen je nach Bestimmungszweck wie folgt:

- Interne Wand- und Bodenbeläge in m: 5 x 5 o 6 x 4;

- Außenböden und -fassaden in m: 3 x 3 o 4 x 2,5.

Für nähere Informationen über die Anlegung und Anordnung der Dehnungsfugen siehe die Bezugsnormen.

При выполнении любых операций укладки плитки предусмотрено изготовление ряда расширительных швов, которые придают полу необходимую упругость и предотвращают скапливание напряжений, способных повредить готовую поверхность. Расширительные швы могут создаваться при выполнении работ или быть уже готовыми. В любом случае, как правило, их ширина составляет от 5 до 12 мм. Расположение швов должно быть рассчитано при составлении проекта проектировщиком или руководителем работ так, чтобы отделить квадратные или прямоугольные участки, соотношение между сторонами которых, по мере возможности, должно быть менее 1,5. Как правило, в зависимости от назначения поверхности размеры этих участков составляют:

- настил полов и облицовка стен в помещениях, м: 5 x 5 или 6 x 4;
- настил наружных полов, наружные фасады, м: 3 x 3 или 4 x 2,5.

Для получения дополнительной информации о создании и расположении швов необходимо сослаться на нормативные документы.

spigolo del taglio - con tazza foragres di piccolo diametro) ed, in un secondo momento, collegarli attraverso tagli lineari ottenendo in questo modo un rilassamento delle tensioni sui vertici della piastrella tagliata. Per ogni tipo di lavorazione sulla piastrella (taglio, spacco, foro) si consiglia di utilizzare utensili e strumentazione idonea per grès porcellanato.

Adhesive must be spread using a notched trowel to ensure an even layer of adhesive. Make sure that the back face of the tile is entirely spread with adhesive (this will ensure perfect adhesion and correct installation of the floor). When envisaged by the UNI standard, we recommended double spreading, in particular for tiles with sides longer than 60 cm. Spread adhesive on small sections of the screed (1 square metre maximum) to prevent a film forming on the adhesive, which would compromise adhesion; if a film forms, brush the trowel over the adhesive again. Take tiles from several boxes to obtain a random effect and prevent 'corridors' or areas that are not attractive to look at; this becomes necessary when installing top value (V) tiles. Exert light pressure on the tile

in order to ensure perfect adhesion of the back face of the tile. You can use a rubber mallet to tap the surface of the tile (pay attention when using a mallet on white or light coloured surfaces. The rubber coating of the mallet may be black and leave marks that are not easy to remove. If you are installing light coloured tiles, it is recommended to wrap the mallet's head with gummed paper). Use spacers for obtaining the joints best suiting the type of product chosen and the intended use (by way of example, for elegant tiles joints should be 2/3 mm and for country-style, rustic tiles 3 mm or more). A minimum joint of 2 mm is recommended to avoid installation without joints. When installing plank-sized or rectangular sizes to form brick wall patterns, it is recommended to offset tiles by one third of their longer length at the most. All around the room and around pillars, columns and raised elements, pay particular attention when performing right angle cuts: it is recommended to first cut a round hole (near the corner of the cut - using a small Foragres cutting disc) and then connect by means of linear cuts. This will reduce stress on the corners of the cut tile. For any type of work on the tile (cutting, splitting, drilling), always use tools and instruments especially made for porcelain stoneware.

La colle doit être étalée à l'aide d'une spatule à dents pour obtenir une épaisseur uniforme de la couche appliquée. Il faut en outre s'assurer que le carreau est complètement « mouillé » au dos (en ce sens que la colle doit bien recouvrir toute la surface), ce qui permettra d'éviter la formation de vides qui risqueraient de compromettre le bon fonctionnement du carrelage. Il est conseillé d'adopter le double encollage lorsque la norme UNI le prévoit, notamment en cas de carreaux présentant un côté de plus de 60 cm de long. Étaler la colle sur des petites portions de chape (1 m² maxi), de manière à ce que la surface en contact avec l'air ne commence à sécher en compromettant le pouvoir adhésif ; si cet inconvénient devait se vérifier, réactiver la colle en l'étalant de nouveau à l'aide de la spatule. Prendre les carreaux dans plusieurs cartons pour obtenir l'effet granito et éviter la formation de bandes ou de zones inesthétiques. Cette mesure est encore plus nécessaire en cas d'utilisation de carreaux à haute valeur (V). Exercer une légère pression sur le carreau de manière à ce que la colle adhère bien au dos. Pour ce faire, utiliser éventuellement un marteau avec tête en caoutchouc et taper légèrement pour bien répartir la colle (faire attention en cas d'utilisation du marteau sur des carreaux blancs ou clairs étant donné que la partie en caoutchouc noire pourrait laisser des traces difficiles à éliminer sur la surface ; en cas de coloris clairs, il convient de recouvrir la tête du marteau avec du papier gommé). Utiliser les bons croisillons pour obtenir des joints appropriés au type de produit et à son utilisation (ex. : pour des carreaux élégants des entretoises de 2/3 mm et pour des carreaux rustiques des entretoises à partir de 3 mm). Il est toutefois conseillé de prévoir des joints d'une largeur minimale de 2 mm et d'éviter les poses juxtaposées, à savoir sans joints. Pour la pose en décalé de lames et de formats rectangulaires, les décaler d'1/3 maximum

par rapport à la longueur de leur côté le plus long. Sur tout le périmètre du local et tout autour des piliers, des colonnes et des surélévations de la surface, il faudra faire particulièrement attention en cas de découpe à angle droit des carreaux : il est tout d'abord conseillé de percer un trou rond (à proximité du bord coupé - avec une fraise à trou de petit diamètre pour grès), puis de les assembler par le biais de découpes linéaires de manière à réduire les tensions aux sommets du carreau découpé. Pour toute opération à effectuer sur le carreau (découpe, fente, trou), utiliser des outils et des instruments spécialement conçus pour le grès cérame.

Der Kleber ist mit einer Zahnspachtel aufzutragen, die eine möglichst gleichmäßige Stärke der Kleberschicht gewährleistet. Es ist sicherzustellen, dass die Fliesenrückseite vollständig, benetzt ist, das heißt, dass der Kleber die gesamte Oberfläche bedeckt. Damit werden nicht verklebte Stellen bzw. Hohlräume vermieden, die später am Boden Probleme verursachen könnten. Falls von der UNI-Norm verlangt, empfehlen wir den doppelten Auftrag, insbesondere bei mehr als 60 cm langen Fliesen. Den Kleber über jeweils kleine Flächen von maximal 1 qm auf den Estrich auftragen, damit sich auf der Oberfläche durch den Kontakt mit der Luft keine „Haut“ bildet und der Kleber vorzeitig antrocknet, was sein Klebevermögen beeinträchtigen könnte. Sollte dies geschehen, den aufgetragenen Kleber nochmals mit der Spachtel auffrischen. Verlegen Sie stets Fliesen aus mehreren Schachteln zugleich, um die leichten Fliesenvariationen gleichmäßig zu verteilen und eine unerwünschte Streifen- oder Zonenbildung zu vermeiden. Dies ist umso erforderlicher, wenn Fliesen mit einem hohen V-Wert verlegt werden. Drücken Sie die Fliesen leicht an, damit der Kleber gut an der Rückseite anhaftet; klopfen Sie sie zur guten Verteilung des Klebers gegebenenfalls leicht mit einem Gummihammer an. Bei weißen bzw. hellen Fliesen ist Vorsicht geboten, da der schwarze Gummi Flecken hinterlassen könnte, die eventuell nicht sofort entfernt werden. In diesem Fall sollte der Hammer mit Abdeckband unwickelt werden. Verwenden Sie passende Distanzstücke zur Erzielung der dem verlegten Produkt und der Zweckbestimmung angemessenen Fugen (für elegante Fliesen beispielsweise 2-3 mm-Fugenkreuze, für rustikale Fliesen 3 mm und größer). In jedem Fall sollten die Fliesen nicht fugenlos aneinandergelagt, sondern mit mindestens 2 mm breiten Fugen verlegt werden. Für die Verlegung von rechteckigen und Dielenformaten empfiehlt sich, die Fliesen bei „fortlaufender Verlegung“ um maximal 1/3 ihrer langen Seite versetzt zu positionieren. Am gesamten Umfang des Raums sowie um Pfeiler, Säulen und Erhöhungen ist besondere Aufmerksamkeit geboten, wenn Fliesen rechtwinklig geschnitten werden müssen: Es empfiehlt sich, zunächst ein rundes Loch auszuführen (an der Schnittkante - mit Topflochfräser für Feinsteinzeug mit kleinem Durchmesser) und anschließend geradlinige Verbindungsschnitte vorzunehmen. Auf diese Weise werden die Spannungen an den Eckpunkten der geschnittenen Fliese entlastet. Für jede Bearbeitung an der Fliese (Schnitt, Bruch, Bohrung) sollten für Feinsteinzeug geeignete Spezialwerkzeuge und

-instrumente verwendet werden.

Клей следует наносить при помощи зубчатого шпателя, обеспечивающего равномерную толщину клеевого слоя. Необходимо убедиться, что тыльная сторона плитки полностью "смочена", то есть, что вся ее поверхность покрыта клеем (во избежание наличия несклееных участков или пустот, которые могут помешать надлежащему использованию пола). Там, где это предусмотрено стандартами UNI, мы рекомендуем использовать метод двойного намазывания, в частности, для плитки, у которой одна из сторон длиннее 60 см. Нанесите клей на неболь шие участки стяжки, размером не более 1 кв.м., для того, чтобы при контакте с воздухом на поверхности клея не образовалась "пленка", то есть, чтобы он не начал схватываться, ухудшая клеящую способность. В случае появления пленки клей необходимо освежить, обрабатывая его шпателем. Берите плитку из нескольких коробок одновременно для получения "рассыпанного" эфффекта и для предотвращения образования однородных дорожек или участков, которые плохо смотрятся. Этот прием становится еще более целесообразным в случае использования плитки с высоким значением (V). Слегка нажмите на плитку для того, чтобы клей пристал к ее задней стороне, при необходимости можно постукивать резиновой киянкой для улучшения сцепления (будьте осторожны при использовании киянки с белой или светлой плиткой, потому что черная резина может оставить трудноудаляемые следы на поверхности плитки. При наличии светлой плитки рекомендуется покрыть верхнюю часть киянки липкой лентой). Используйте необходимые распорки для получения межплиточных швов, наиболее подходящих для типа изделий и сферы назначения (например, с изысканной плиткой следует применять распорки в 2/3 мм, с плиткой в деревенском стиле - распорки размером 3 мм и более). В любом случае, рекомендуется минимальный размер межплиточного шва в 2 мм, не укладывайте плитку встык, без швов. Для укладки «с разгоном» плитки в виде досок и прямоугольных форматов рекомендуется смещать доски максимум на 1/3 длинной стороны. По всему периметру помещения, вокруг пилястров, колонн, повышений уровня необходимо уделять особое внимание в случае, если требуется резка плитки под прямым углом: рекомендуется сначала выполнить круглые отверстия рядом с углом резки, используя коронку небольшого диаметра для керамогранита, и потом соединить их линейной резкой. Таким образом, снимается напряжение в вершинах углов вырезаемой плитки. При выполнении любого вида обработки плитки (резка, слом, сверление отверстий) рекомендуется применять инструмент и приборы, предназначенные для керамогранита.

TECHNICAL DETAILS

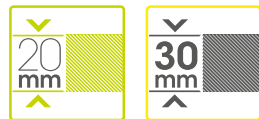

Posa a secco - Aextra20/ Aextra30

Dry-system installation - Aextra20/Aextra30 - Pose à sec - Aextra20/Aextra30

Trockenverlegung - Aextra20/Aextra30 - Сухая укладка - Aextra20/Aextra30

Le pavimentazioni da esterno posate a secco in quota sono soggette all'azione del vento, con il rischio di sollevamento delle lastre. Il produttore raccomanda di far verificare l'idoneità del sistema di posa in quota da un tecnico abilitato in base alla normativa locale vigente ed alle condizioni d'uso, al fine di evitare il rischio di danni a persone e cose. Una lastra ceramica posata su un sistema sopraelevato può rompersi per impatto qualora un oggetto pesante cada sulla stessa da una certa altezza, con il rischio di seri danni per chiunque possa sostare o transitare sulla piastrella stessa. Il mancato rispetto delle istruzioni fornite dal produttore relative alla posa su sistemi sopraelevati può provocare seri danni alla persone. Per maggiori informazioni e raccomandazioni di posa si rimanda alla sezione AEXTRA20 del sito web: www.caesar.it o al catalogo AEXTRA20.

Outdoor pavings installed unglued above the ground level are subject to the action of the wind, with the risk, in some cases, of becoming airborne. The manufacturer recommends to require the assistance of a qualified professional in order to check the suitability of the installation system above the ground adopted, in accordance with the local laws and regulations and the conditions of use. Failure to do so could result in serious injury or property damage. A ceramic slab installed on a raised pedestal system may fracture on impact if a heavy object is dropped onto it from a height, with a risk of injury to anyone standing or walking on such slab. Failure to adhere to the manufacturer's instructions

for installation of slabs on raised pedestal systems may result in serious injury. For further information and recommendations concerning the installation systems please refer to www.caesar.it website or to the Aextra20 catalogue.

Les dallages extérieurs posés sans collage sont soumis à l'action du vent, avec le risque de soulèvement des plaques, notamment ceux posés aux étages d'un bâtiment. Le fabricant recommande de faire vérifier par un technicien qualifié la bonne adaptation du système de pose en étages avec la réglementation en vigueur et les conditions d'utilisation locales, afin d'éviter le risque de dommages aux personnes et aux biens. Une dalle céramique posée sur un système surélevé peut se casser à la suite d'un impact d'un objet lourd qui y chuterait d'une certaine hauteur, avec le risque de sérieux dommages pour quiconque stationnerait ou transiterait sur ce carreau. Le non respect des instructions fournies par le fabricant relatives à la pose sur des systèmes surélevés peut provoquer de sérieux dommages aux personnes. Pour toutes informations complémentaires et recommandations de pose, veuillez vous référer à notre site www.caesar.it ou à notre catalogue Aextra20.

Bodenbeläge, die trocken im Außenbereich in der Höhe verlegt werden, unterliegen der Wirkung des Windes, wodurch die Gefahr besteht, dass die Platten aufgeworfen werden. Der Hersteller empfiehlt daher, dass die Eignung des Systems für eine Verlegung in der Höhe durch einen zugelassenen Sachverständigen überprüft wird, wobei die lokal gültigen Vorschriften und Nutzungsbedingungen zu

beachten sind, um die Gefahr von Personen- und Sachschäden zu vermeiden. Eine Keramikplatte, die auf einem Doppelbodensystem verlegt ist, kann durch den Aufprall eines aus einer bestimmten Höhe herabfallenden Gegenstandes zerbrechen. Hier besteht das Risiko schwerer Verletzungen für alle, die auf der Fliese gehen oder stehen. Bei Nichtberücksichtigung der vom Hersteller vorgegebenen Verlegevorschriften für Doppelbodensysteme kann es zu schweren Verletzungen der Personen kommen. Für genauere Informationen und Verlegehinweise verweisen wir auf unsere Webseite www.caesar.it oder auf unseren Katalog Aextra20.

Уличные покрытия, уложенные бесклеевым способом на опоры, подвержены воздействию ветра и, как следствие, риску подъема или отрыва плиток. Поэтому во избежание травмирования людей или повреждения имущества пригодность системы укладки для соответствующих условий эксплуатации и ее соответствие местным нормам и правилам должны быть проверены квалифицированным специалистом. Падение тяжелого предмета с большой высоты может повлечь за собой разлом уложенной на опоры плитки с риском получения травмы для того, кто находится на плитке. Несоблюдение инструкций производителя по укладке на опоры может стать причиной серьезного травмирования. Более подробная информация и рекомендации по укладке доступны на нашем сайте www.caesar.it или в нашем каталоге Aextra20.

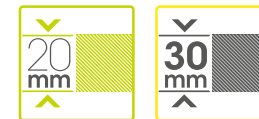

Istruzioni per committenti e progettisti

Instructions for project engineers and customers - Modalités pour concepteurs, maîtres d'oeuvre et/ou aux maîtres d'ouvrage

Anweisungen für Auftraggeber und Planer - Рекомендации для заказчиков и проектировщиков

Quando l'applicazione delle lastre in 20 mm e 30 mm prevede l'utilizzo del prodotto ceramico in termini strutturali, si raccomanda al progettista e/o committente una attenta valutazione dei requisiti del progetto in relazione alle caratteristiche tecniche delle lastre. In particolare, al fine di evitare il rischio di danni a persone o cose il produttore raccomanda:

- Se l'applicazione prevede la posa sopraelevata, tenendo conto che una piastrella potrebbe rompersi in seguito alla caduta su di essa di un corpo pesante, verificare anticipatamente la destinazione d'uso specifica e attenersi alla tabella istruzioni di posa sopraelevata di seguito riportata ove, in determinate condizioni, è prevista l'applicazione di un rinforzo sul retro della piastrella (doppia rete in fibra di vetro) fornito dal produttore;

- Con riferimento alla pavimentazione posata in quota, con qualunque sistema di posa a secco, rispettare le specifiche normative e condizioni d'uso locali riguardanti, tra l'altro, a titolo esemplificativo, l'azione del vento, il carico strutturale, le azioni sismiche, ecc.;

- Il mancato rispetto delle raccomandazioni sopra riportate possono portare ad un utilizzo improprio del prodotto e causare eventualmente gravi danni a persone o cose.

If the application of the 20 - 30 mm slabs foresees the ceramic product used in structural installations, the project engineer and/or customer must carefully assess the project requirements with regard to the technical specifications of the slabs. To prevent the risk of damage or injury, the manufacturer recommends:

- With regard to a raised floor installation a ceramic slab may fracture on impact if a heavy object falls on it from any significant height. Therefore the manufacturer recommends to check the specific intended use before starting the installation and to follow table for raised installation n provided below. In certain conditions, reinforcing must be applied on the back of the slabs (double glass fibre net) supplied and applied by the manufacturer;

- With reference to any dry installation system of

flooring above the ground level, the manufacturer recommends to comply with local regulations and conditions of use with regard to wind-load, loadbearing, seismic events, etc.

- Failure to comply with these recommendations may lead to improper use of the product and could cause serious damage or injury.

Lorsque la mise en oeuvre de dalles de 20 mm et 30 mm prévoit l'utilisation du produit céramique en termes structurels, il est recommandé aux concepteurs, maîtres d'oeuvre et/ou aux maîtres d'ouvrage de faire une évaluation scrupuleuse du cahier des charges du projet eu égard aux caractéristiques techniques des dalles. En particulier, afin d'éviter le risque de dommages aux personnes ou aux biens, le fabricant recommande:

- Si la mise en oeuvre prévoit une pose surélevée, en tenant compte qu'un carreau pourrait se casser suite à la chute d'un corps lourd, de vérifier en avance la destination d'usage spécifique et de se conformer au tableau d'instructions de pose surélevée reproduit ci-après, où, dans des conditions déterminées, il est prévu de rajouter un renforcement sur le revers du carreau (double treillis en fibre de verre), fourni par le fabricant.

- Concernant le dallage posé en étages, quelque soit le système de pose sans collage utilisé, de respecter les spécifications des normes et les conditions locales d'emploi, entre autre, à titre d'exemple, l'action du vent, le chargement structurel, les actions sismiques, etc.

Le non respect des recommandations reproduites ci-dessus peut conduire à un usage improprie du produit et éventuellement causer de graves dommages aux personnes ou aux biens.

Wenn 20 mm oder 30 mm starke Platten strukturell verwendet werden sollen, sollten der Planer und/oder der Bauherr die Entsprechung der technischen Merkmale der Platten und die Projektmerkmale sorgfältig prüfen. Zur Vermeidung potenzieller Personen- oder Sachschäden empfiehlt der Hersteller insbesondere Folgendes:

- Bei der Verlegung als Doppelboden muss vorab die spezifische Zweckbestimmung berücksichtigt werden, da bei Herabfallen eines schweren

Gegenstands Fliesen brechen könnten. Hierzu ist nachstehende Tabelle für die Doppelbodenverlegung zu beachten, denn unter bestimmten Bedingungen ist an der Fliesenrückseite eine vom Hersteller gelieferte Verstärkung anzubringen (doppeltes GFK-Netz);

- Bei der Verlegung hoch gelegener Böden sind bei jedem Trockenbausystem die einschlägigen Richtlinien und die örtlichen Bestimmungen wie beispielsweise jene, die den Wind, die strukturelle Belastung, seismische Faktoren etc. betreffen, zu beachten;

- Die Nichtbeachtung der obigen Empfehlungen kann eine unsachgemäße Verwendung des Produkts darstellen und zu schweren Personen- oder Sachschäden führen.

Когда применение плит толщиной 20 и 30 мм осуществляется в несущих конструкциях, проектировщику и/или заказчику рекомендуется внимательно изучить требования проекта с учетом технических характеристик плит. В частности, чтобы предотвратить опасность нанесения ущерба людям или имуществу, производитель рекомендует:

- если использование предусматривает укладку на фальшпол, учитывая, что плитка может разбиться в результате падения на нее тяжелого предмета, заранее проверить конкретный тип назначения и придерживаться приведенной ниже таблицы с инструкциями по укладке на фальшпол, в которой, при определенных условиях, предусматривается установка усиления на тыльную сторону плитки (двойная стекловолоконная сетка), поставляемого производителем;







- при настиле полов на высоте, при использовании любой системы сухой укладки, соблюдать специальные местные нормы и условия, касающиеся, например, воздействия ветра, нагрузок на несущие конструкции, сейсмического воздействия и т.д.;

- Несоблюдение вышеизложенных рекомендаций может стать причиной использования изделия не по назначению и нанесения серьезного ущерба людям или имуществу.

ISTRUZIONI PER LA POSA SOPRAELEVATA - INSTRUCTIONS FOR RAISED FLOOR INSTALLATION - INSTRUCTIONS POUR LA POSE SURÉLEVÉE
ANWEISUNGEN FÜR DIE DOPPELBODENVERLEGUNG - УКАЗАНИЯ ПО УКЛАДКЕ В ВИДЕ ФАЛЬШПОЛА

| Formato Size Format Format | Altezza della sopraelevazione - Raise of the foot plan - Hauteur de la surélévation - Höhe des Doppelbodens - Высота монтажа | | |
|-----------------------------------------------------------------------------------------------------|--------------------------------------------------------------------------------------------------------------------------------------------------------------------------------------------------------------------------------------------------------------------------------------------------------------------------------------------------------------------------------------------------------------------------------------------------------------------------------------------------------------------------------------------------------------------------------------------|--------------------------------------------------------------------------------------------------------------------------------------------------------------------------------------------------------------------------------------------------------------------------------------------------------------------------------------------------------------------------------------------------------------------------------------------------------------------------------------------------------------------------------------------------------------------------------------------------------------------------------------------------------------------------------------------------------------------------------------------------------------------------------------------------------------------------------------------------------------------------------------------------------------------------------------------------------------------------------------------------------------------------------------------------------------------------------------------------------------------|-------------------------------------------------------------------------------------------|
| | Fino a 2 cm Up to - Jusqu'à Bis zu - До | Tra 2 e 10 cm From 2 to 10 cm Entre 2 et 10 cm 2 bis 10 cm От 2 до 10 см | Tra 10 e 30 cm From 10 to 30 cm Entre 10 et 30 cm 10 bis 30 cm От 10 до 30 см |
|  60x60 | 4 SUPPORTI/LASTRA (3,4 SUPPORTI/MQ) 4 supports/slab (3,4 supports/mq) 4 supports / dalle (3,4 supports / m²) 4 Träger/Platte (3,4 Träger/qm) 4 опор/плитку (опоры/кв.м) | 4 SUPPORTI/LASTRA (3,4 SUPPORTI/MQ) + APPLICAZIONE DOPPIA RETE IN FIBRA DI VETRO OPPURE AEXTRADECK + APPLICAZIONE DOPPIA RETE IN FIBRA DI VETRO 4 supports/slab (3,4 supports/mq) + application of a double glass fibre net or AextraDeck + application of a double glass fibre net 4 supports / dalle (3,4 supports / m²) + application double treillis en fibre de verre ou AextraDeck + application double treillis en fibre de verre 4 Träger/Platte (3,4 Träger/qm) + Aufkleben eines doppelten GFK-Netztes oder AextraDeck + Aufkleben eines doppelten GFK-Netztes 4 опор/плитку (3,4 опоры/кв.м) + двойная стекловолоконная сетка или AextraDeck + двойная стекловолоконная сетка | |
|  60x120 45x90 | 6 SUPPORTI/LASTRA (FORMATO 60x120: 3,4 SUPPORTI/MQ) (FORMATO 45x90: 6 SUPPORTI/MQ) (FORMATO 60x90: 4,5 SUPPORTI/MQ) 6 supports/slab (Size 60x120: 3,4 supports/mq) (Size 45x90: 6 supports/mq) (Size 60x90: 4,5 supports/mq) 6 supports / dalle (Format 60x120: 3,4 supports / m²) (Format 45x90: 6 supports / m²) (Format 60x90: 4,5 supports / m²) 6 Träger/Platte (Format 60x120: 3,4 Träger/qm) (Format 45x90: 6 Träger/qm) (Format 60x90: 4,5 Träger/qm) 6 опор/плитку (формат 60x120: 3,4 опоры/кв.м) (формат 45x90: 6 опоры/кв.м) (формат 60x90: 4,5 опоры/кв.м) | 6 SUPPORTI/LASTRA (FORMATO 60x120: 3,4 SUPPORTI/MQ) (FORMATO 45x90: 6 SUPPORTI/MQ) (FORMATO 60x90: 4,5 SUPPORTI/MQ) + APPLICAZIONE DOPPIA RETE IN FIBRA DI VETRO OPPURE AEXTRADECK + APPLICAZIONE DOPPIA RETE IN FIBRA DI VETRO 6 supports/slab (Size 60x120: 3,4 supports/mq) (Size 45x90: 6 supports/mq) (Size 60x90: 4,5 supports/mq) + application of a double glass fibre net or AextraDeck + application of a double glass fibre net 6 supports / dalle (Format 60x120: 3,4 supports / m²) (Format 45x90: 6 supports / m²) (Format 60x90: 4,5 supports / m²) + application double treillis en fibre de verre ou AextraDeck + application double treillis en fibre de verre 6 Träger/Platte (Format 60x120: 3,4 Träger/qm) (Format 45x90: 6 Träger/qm) (Format 60x90: 4,5 Träger/qm) + Aufkleben eines doppelten GFK-Netztes AextraDeck oder AextraDeck + Aufkleben eines doppelten GFK-Netztes 6 опор/плитку (формат 60x120: 3,4 опоры/кв.м) (формат 45x90: 6 опоры/кв.м) (формат 60x90: 4,5 опоры/кв.м) + двойная стекловолоконная сетка или AextraDeck + двойная стекловолоконная сетка | |
|  60x90 | 6 SUPPORTI/LASTRA (7 SUPPORTI/MQ) 6 supports/slab (7 supports/mq) 6 supports / dalle (7 supports / m²) 6 Träger/Platte (7 Träger/qm) 6 опор/плитку (7 опоры/кв.м) | 6 SUPPORTI/LASTRA (7 SUPPORTI/MQ) + APPLICAZIONE DOPPIA RETE IN FIBRA DI VETRO OPPURE AEXTRADECK + APPLICAZIONE DOPPIA RETE IN FIBRA DI VETRO 6 supports/slab (7 supports/mq) + application of a double glass fibre net or AextraDeck + application of a double glass fibre net 6 supports / dalle (7 supports / m²) + application double treillis en fibre de verre ou AextraDeck + application double treillis en fibre de verre 6 Träger/Platte (7 Träger/qm) + Aufkleben eines doppelten GFK-Netztes oder AextraDeck + Aufkleben eines doppelten GFK-Netztes 6 опор/плитку (7 опоры/кв.м) + двойная стекловолоконная сетка или AextraDeck + двойная стекловолоконная сетка | |
|  30x120 | 6 SUPPORTI/LASTRA (7 SUPPORTI/MQ) 6 supports/slab (7 supports/mq) 6 supports / dalle (7 supports / m²) 6 Träger/Platte (7 Träger/qm) 6 опор/плитку (7 опоры/кв.м) | 6 SUPPORTI/LASTRA (7 SUPPORTI/MQ) + APPLICAZIONE DOPPIA RETE IN FIBRA DI VETRO OPPURE AEXTRADECK + APPLICAZIONE DOPPIA RETE IN FIBRA DI VETRO 6 supports/slab (7 supports/mq) + application of a double glass fibre net or AextraDeck + application of a double glass fibre net 6 supports / dalle (7 supports / m²) + application double treillis en fibre de verre ou AextraDeck + application double treillis en fibre de verre 6 Träger/Platte (7 Träger/qm) + Aufkleben eines doppelten GFK-Netztes oder AextraDeck + Aufkleben eines doppelten GFK-Netztes 6 опор/плитку (7 опоры/кв.м) + двойная стекловолоконная сетка или AextraDeck + двойная стекловолоконная сетка | |
|  80x80 | 4 SUPPORTI/LASTRA (2,4 SUPPORTI/MQ) 4 supports/slab (2,4 supports/mq) 4 supports / dalle (2,4 supports / m²) 4 Träger/Platte (2,4 Träger/qm) 4 опор/плитку (2,4 опоры/кв.м) | AEXTRADECK + APPLICAZIONE DOPPIA RETE IN FIBRA DI VETRO AextraDeck + application of a double glass fibre net AextraDeck + application double treillis en fibre de verre AextraDeck + Aufkleben eines doppelten GFK-Netztes AextraDeck + двойная стекловолоконная сетка | |
|  120x120 | 8 SUPPORTI/LASTRA (2,7 SUPPORTI/MQ) 8 supports/slab (2,7 supports/mq) 8 supports / dalle (2,7 supports / m²) 8 Träger/Platte (2,7 Träger/qm) 8 опор/плитку (2,7 опоры/кв.м) | AEXTRADECK + APPLICAZIONE DOPPIA RETE IN FIBRA DI VETRO AextraDeck + application of a double glass fibre net AextraDeck + application double treillis en fibre de verre AextraDeck + Aufkleben eines doppelten GFK-Netztes AextraDeck + двойная стекловолоконная сетка | |

INSTRUCTIONS FOR RAISED FLOOR INSTALLATION - USA - CANADA - OCEANIA
INSTRUCTIONS POUR LA POSE SURÉLEVÉE - ETATS UNIS - CANADA - Océanie

| Size - Format | Raise of the foot plan - Hauteur de la surélévation | |
|----------------------------------------------------------------------------------------------------------------------------|----------------------------------------------------------------------------------------------------------------------------------------------------------------------------------------|--------------------------------------------------------------------------------------------------------------------------------|
| | Up to 3/4 inch - Jusqu'à 3/4 pouces (2cm) | Above 3/4 inch - Au-delà de 3/4 pouces (2cm) |
|  Size 23 5/8" x 23 5/8" (60x60cm) | 4 supports/slab (0,32 supports/sqf - 3,4 supports/mq) 4 supports /dalle (0,32 supports /sqf - 3,4 supports/m²) | Please contact Ceramiche Caesar (Caesartech dept.) Veuillez consulter Ceramiche Caesar (Service Caesartech) |
|  Size 23 5/8" x 47 2/8" (60x120cm) | 6 supports/slab (Size 60x120: 0,32 supports/sqf - 3,4 supports/mq) (Size 45x90: 0,56 supports/sqf - 6 supports/mq) (Size 60x90: 0,42 supports/sqf - 4,5 supports/mq) | |
|  Size 17 11/16" x 35 7/16" (45x90cm) | 6 supports/slab (Format 60x120: 0,32 supports /sqf - 3,4 supports/m²) (Format 45x90: 0,56 supports /sqf - 6 supports/m²) (Format 60x90: 0,42 supports /sqf - 4,5 supports/m²) | |
|  Size 23 5/8" x 35 7/16" (60x90cm) | 6 supports/slab (0,65 supports/sqf - 7 supports/mq) 6 supports/dalle (0,65 supports/sqf - 7 supports/m²) | |
|  Size 11 13/16" x 47 2/8" (30x120cm) | 6 supports/slab (0,65 supports/sqf - 7 supports/mq) 6 supports/dalle (0,65 supports/sqf - 7 supports/m²) | |
|  Size 31 4/8" x 31 4/8" (80x80cm) | 4 supports/slab (2,4 supports/sqf - 2,4 supports/mq) 4 supports/dalle (2,4 supports /sqf - 2,4 supports/m²) | |
|  Size 47 2/8" x 47 2/8" (120x120cm) | 8 supports/slab (2,7 supports/sqf - 2,7 supports/mq) 8 supports/dalle (2,7 supports /sqf - 2,7 supports/m²) | |

ISTRUZIONI PER LA POSA SOPRAELEVATA AEXTRA30 PER TUTTI I MERCATI, ESCLUSI USA, CANADA, OCEANIA - INSTRUCTIONS FOR AEXTRA30
RAISED INSTALLATION FOR ALL MARKETS, WITH THE EXCEPTION OF THE USA, CANADA, OCEANIA - INSTRUCTIONS POUR LA POSE SURÉLEVÉE
- AEXTRA30 POUR TOUS LES MARCHÉS, SAUF USA, CANADA, Océanie - VERLEGUNG ALS DOPPELBODEN AEXTRA30 FÜR ALLE MÄRKTE AUSSER
USA, KANADA, OZEANIEN - УКЛАДКА АЕХТРА30 В КАЧЕСТВЕ ФАЛЬШПОЛА ДЛЯ ВСЕХ РЫНКОВ, КРОМЕ США, КАНАДЫ, ОКЕАНИИ

| Formato Size Format Format | Altezza della sopraelevazione - Raise of the foot plan - Hauteur de la surélévation - Höhe des Doppelbodens - Высота монтажа | |
|----------------------------------------------------------------------------------------------|--------------------------------------------------------------------------------------------------------------------------------------------------------------------------------------------|----------------------------------------------------------------------------------------------------------------------------------------------------------------------------------------------------------------------------------------------------------------------------------------------------------------------------------------------------------------------------------------------------------------|
| | Fino a 10 cm Up to - Jusqu'à - Bis zu - До | Tra 10 e 30 cm From 10 to 30 cm Entre 10 et 30 cm 10 bis 30 cm От 10 до 30 см |
|  60x60 | 4 SUPPORTI/LASTRA (3,4 SUPPORTI/MQ) 4 supports/slab (3,4 supports/mq) 4 supports / dalle (3,4 supports / m²) 4 Träger/Platte (3,4 Träger/qm) 4 опор/плитку (опоры/кв.м) | 4 SUPPORTI/LASTRA (3,4 SUPPORTI/MQ) + APPLICAZIONE DOPPIA RETE IN FIBRA DI VETRO 4 supports/slab (3,4 supports/mq) + application of a double glass fibre net 4 supports / dalle (3,4 supports / m²) + application double treillis en fibre de verre 4 Träger/Platte (3,4 Träger/qm) + Aufkleben eines doppelten GFK-Netztes 4 опор/плитку (3,4 опоры/кв.м) + двойная стекловолоконная сетка |

INSTRUCTIONS FOR RAISED FLOOR INSTALLATION - USA - CANADA - OCEANIA
INSTRUCTIONS POUR LA POSE SURÉLEVÉE - ETATS UNIS - CANADA - Océanie

| Size - Format | Raise of the foot plan - Hauteur de la surélévation | | |
|-------------------------------------------------------------------------------------------------------------------------|-------------------------------------------------------------------------------------------------------------------|----------------------------------------------------------|----------------------------------------------------------------|
| | Up to 3/4 inch - Jusqu'à 3/4 pouces (2cm) | Above 3/4 inch - Au-delà de 3/4 pouces (2cm) | |
|  Size 23 5/8" x 23 5/8" (60x60cm) | 4 supports/slab (0,32 supports/sqf - 3,4 supports/mq) 4 supports /dalle (0,32 supports /sqf - 3,4 supports/m²) | Please contact Ceramiche Caesar (Caesartech dept.) | Veuillez consulter Ceramiche Caesar (Service Caesartech) |

Consigli per la stuccatura

Advice for grouting - Conseils pour le Jointoiment

Empfehlungen für das Verfugen - Рекомендации по заполнению швов

Trascorso il tempo necessario al collante per fare presa sul sottofondo (fare riferimento alle indicazioni sulle confezioni dei collanti) si può procedere alla stuccatura, cioè al riempimento delle fughe. Prima di procedere bisogna accertarsi che le fughe siano vuote, libere da qualsiasi materiale che si dovesse essere inserito, come polvere, sabbia, segatura etc; è consigliabile pulire le fughe con spazzole o scope asportando eventuali materiali estranei. Gli stucchi abitualmente utilizzati per il riempimento delle fughe tra piastrella e piastrella sono di varia natura e di conseguenza variano anche le metodologie ed i detergenti adatti ad eliminare i residui che rimangono sulla superficie in fase di posa e che spesso risultano essere la causa principale della sporcabilità della stessa. I principali stucchi utilizzati sono:

- Cementizi (Puri o Additivati)
- Epossidici

Alcune precauzioni da tenere presenti durante la fase di fugatura sono le seguenti:

- È buona norma provare a fugare solo una piccola porzione di superficie in modo da determinare se il materiale fugante, ovvero i pigmenti in esso contenuti, provocano problemi di macchiatura sulle piastrelle, in particolar modo nel caso in cui si vogliono ottenere dei forti contrasti, fugando piastrelle di colore chiaro con stucchi scuri, e viceversa.
- La stuccatura della superficie deve essere eseguita per zone ristrette, eliminando subito lo stucco in eccesso.
- Occorre lasciare asciugare lo stucco il tempo

After the necessary adhesion time (refer to the

necessario affinché indurisca, e questo dipende dalle caratteristiche dello stucco stesso: in linea di massima il tempo può variare dalle 24 alle 72 ore in funzione della temperatura al momento presente. Il grès porcellanato deve essere considerato e trattato come ogni altro materiale da pavimentazione e da rivestimento; per questo motivo è raccomandabile proteggere il materiale posato ricoprendolo in modo da preservarlo dai materiali di risulta di successive lavorazioni di cantiere. L'uso di fogli di plastica protettivi è sconsigliato in quanto, non facendo circolare l'aria, rallentano il processo di idratazione e quindi di indurimento dello stucco. Altra regola di carattere generale prevede che lo stucco sia scelto possibilmente di colore simile alle piastrelle posate. Nota sugli stucchi epossidici: a differenza degli stucchi cementizi, gli stucchi epossidici una volta induriti non si possono più pulire se non meccanicamente con rischi per la superficie delle piastrelle. Gli eccessi di prodotto vanno eliminati quando sono ancora freschi entro pochi minuti dall'applicazione, prima che il prodotto indurisca, mediante mono spazzola elettrica rotante con uno straccio da pavimento pulito imbevuto di alcool etilico; lo straccio deve essere sostituito frequentemente. Su qualsiasi tipo di stucco cada la scelta tra quelli citati è indispensabile attenersi scrupolosamente alle indicazioni fornite dalle aziende produttrici per quanto riguarda l'utilizzo e i dosaggi tra i vari componenti.

After the necessary adhesion time (refer to the

indications on the adhesive package), you can proceed with grouting, namely filling in the joints between tiles. Before proceeding, make sure that the joints are clean and that no material - such as dust, sand, sawdust, etc. - has built up within them. It is recommended to clean the joints with a brush or broom to remove any foreign matters. There are different types of grouts for joints. The methods for using these products and the detergents for removing any residues, which often compromise cleanability of the finished surface, therefore vary. The most common grouts used are:

- Cement-based (pure or with additives)
- Epoxy-based

Here below are some precautions to take into account when grouting:

- It is a good idea to test your grout on a small portion of the surface to make sure that the grouting material, and in particular the pigments it contains, do not stain the surface of the tiles. This applies in particular when creating strong contrasts between the colour of the tiles and the colour of the grout.
- Always grout small portions of the surface and remove any excess grout immediately.
- Let the grout dry and harden for the time necessary. This time depends on the characteristics of the product used: as a general rule, it ranges from 24 to 72 hours depending on temperature. Porcelain stoneware must be handled and treated in the same manner as any other material for floor and wall covering; for this reason, it is recommended to protect installed

material by covering it so as to protect it from any further work performed. The use of plastic sheets is not recommended as they prevent air circulating, slow down dehydration and therefore grout hardening. Another general rule is that grout should preferably be of a colour similar to the tiles. A note on epoxy-based grout: unlike cement-based grout, once hardened epoxy-based grout cannot be removed unless mechanical means are used, which may lead to damage to the surface of the tiles. Grout surfacing out from the joints must be removed within a few minutes and before the product hardens, using a rotary electric brush with a clean cloth soaked in ethyl alcohol; the cloth must be replaced frequently. Irrespective of the type of grout chosen, follow the instructions of the manufacturer, concerning use and combination of components, with great care.

Attendre le temps nécessaire pour permettre à la colle de bien prendre sur la sous-couche (voir les indications sur les emballages des colles), puis effectuer le jointoiment, à savoir le remplissage des joints. Avant cette opération, s'assurer que les joints sont bien vides et exempts de tout dépôt de matière telle que de la poussière, du sable, de la sciure, etc. Il est conseillé de nettoyer les joints à l'aide de brosses ou de balais pour éliminer toute matière étrangère. Pour le remplissage des joints inter-carreaux, on utilise généralement des stucs de différente nature, ce qui implique différentes méthodes d'application du stuc et d'élimination des résidus de pose sur la surface (cause principale de salissure). Les principaux stucs utilisés sont :

- À Base De Ciment (Purs Ou Adjuvants)
- Époxy

Quelques précautions à prendre durant la phase de jointoiment :

- 1) Commencer le jointoiment sur une petite portion de surface de manière à contrôler qu'il ne tache pas les carreaux (notamment lorsque l'on souhaite obtenir de forts contrastes en effectuant le jointoiment de carreaux clairs avec des stucs foncés et vice versa.
- 2) Le jointoiment de la surface doit être effectué sur de petites longueurs de manière à éliminer immédiatement la partie en trop.
- 3) Laisser sécher le stuc le temps nécessaire à son durcissement (ce temps dépend des caractéristiques du stuc et peut généralement varier de 24 à 72 heures en fonction de la température) Le grès cérame doit être considéré et traité comme tout autre matériau de revêtement, raison pour laquelle il convient de protéger le produit posé et de le recouvrir afin d'en éviter la détérioration par des déchets issus d'autres travaux sur le chantier. Pour ce faire, ne pas utiliser de feuilles en plastique qui ralentiraient le processus d'hydratation et de durcissement du stuc du fait qu'elles ne font pas circuler l'air. Une autre règle importante consiste à choisir un stuc de la même couleur que celle des carreaux posés. Remarque sur les stucs époxy : contrairement aux stucs à base de ciment, les stucs époxy ne peuvent plus être nettoyés après leur durcissement si ce n'est que par des moyens mécaniques qui risqueraient de détériorer la surface des carreaux. Il convient d'éliminer tout excès de produit pas plus de quelques minutes après son application, à savoir avant qu'il ne durcisse. Pour ce faire, utiliser une monobrosse électrique rotative

avec une serpillère propre imbibée d'alcool éthylique ; remplacer fréquemment la serpillère en question. Quel que soit le stuc choisi parmi ceux indiqués, il faut absolument respecter les instructions fournies par les producteurs en ce qui concerne l'utilisation et les dosages des différents composants.

Nach Ablauf der für die Abbindung am Untergrund erforderlichen Zeit (siehe hierzu die Angaben auf der Kleberpackung) kann mit dem Verfugen, das heißt mit dem Füllen der Fugen begonnen werden. Vorab ist sicherzustellen, dass die Fugen leer sind, d.h. frei von jeglichen Materialien wie Pulver, Sand, Sägemehl etc. Es empfiehlt sich, die Fugen mit Bürste oder Besen von jeglichen Fremdkörpern zu säubern. Es gibt verschiedene Arten von Fugenmassen, und entsprechend variieren auch die Verfahren und Reinigungsmittel zur Entfernung der Rückstände, die während der Verlegung an der Fliesenoberfläche verbleiben und häufig die Hauptursache für deren Verschmutzen sind. Die gebräuchlichsten Fugenmassen sind:

- Zement-Fugenmassen (pur oder mit Zusätzen)
- Epoxy-Fugenmassen

Einige Vorsichtsmaßnahmen, die beim Verfugen zu ergreifen sind:

- 1) Zunächst sollte nur ein kleiner Bereich der Oberfläche verfugt werden, um festzustellen, ob die Fugenmasse bzw. die darin enthaltenen Pigmente Flecken auf den Fliesen bilden. Dies gilt insbesondere dann, wenn starke Kontraste erzielt werden sollen und helle Fliesen dunkel verfugt werden oder umgekehrt.
- 2) Jeweils kleine Flächen verfugen und überschüssige Fugenmasse sofort entfernen.
- 3) Die Fugenmasse ausreichend lang aushärten lassen. Die erforderliche Zeit hängt von den Merkmalen der Masse selbst ab: sie kann je nach der herrschenden Temperatur von 24 bis 72 Stunden variieren. Feinsteinzeug ist wie alle anderen Wand- und Bodenbeläge zu behandeln. Das verlegte Material sollte daher abgedeckt werden, um es vor Rückständen späterer Bauarbeiten zu schützen. Von Kunststofffolien ist abzuraten, da diese die Luftzirkulation behindern und die Hydratation und damit das Aushärten der Fugenmasse verlangsamen. Eine weitere, allgemeine Regel lautet, die Fugenmasse farblich möglichst jener der verlegten Fliesen entsprechend zu wählen. Anmerkung zu den Epoxy-Fugenmassen: Anders als Zement-Fugenmassen lassen sich Epoxy-Fugenmassen nach dem Aushärten nur noch mechanisch reinigen, was jedoch die Fliesenoberfläche beschädigen kann. Überschüssiges Produkt ist binnen weniger Minuten nach dem Auftrag zu entfernen, solange es frisch und noch nicht ausgehärtet ist. Hierzu eine Einscheibenmaschine mit einem sauberen, mit Ethanol getränkten Wischtuch, das häufig zu wechseln ist, verwenden. Unabhängig von der aus der genannten Gruppe gewählten Fugenmasse sind die Herstellerhinweise hinsichtlich Verwendung und Dosierung der einzelnen Komponenten streng zu beachten.

По истечении времени схватывания клея на подстилающем слое (ссылайтесь на инструкцию, приведенную на упаковку клея) можно приступить к заделке, то есть, заполнению швов между плитками. Перед выполнением этой операции необходимо убедиться, что швы пустые, свободные от любого материала, попавшего

в них, например, пыль, песок, опилки и т.д. Рекомендуется очистить швы щеткой или метлой, удаляя посторонние материалы. Затирки, обычно используемые для заполнения межплиточных швов, бывают разного типа. Следовательно, меняются также методы и чистящие средства, пригодные для удаления остатков, остающихся на поверхности плитки во время укладки, которые часто являются главной причиной загрязняемости плитки. Основными типами используемых затирок являются:

- цементные (в чистом виде или с добавками)
- эпоксидные

Во время заполнения швов учтите следующие меры предосторожности:

- 1) Рекомендуется сначала заполнить швы только на небольшой поверхности, чтобы определить, пачкается ли плитка затиркой или содержащимися в ней пигментами. Это пригодится особенно в случае, если вы хотите получить заметный контраст между светлым цветом плитки и темным цветом затирки или наоборот.
- 2) Швы необходимо заполнять на небольших участках, сразу же удаляя излишки затирки.
- 3) Необходимо сушить затирку в течение времени, необходимого для ее отвердевания, которое зависит от характеристик затирки. В качестве общего правила можно сказать, что время составляет от 24 до 72 часов, в зависимости от температуры. С керамогранитом необходимо обращаться как и с любым другим материалом для напольной или настенной укладки. Поэтому, рекомендуется защитить уложенный материал, накрывая его во избежание его повреждения отходами от других строительных работ. Не рекомендуется использовать защитную полиэтиленовую пленку, потому что она не пропускает воздух, замедляет процесс гидратации и, следовательно, отвердевания затирки. Другое общее правило гласит, что лучше выбирать затирки цвета, похожего на цвет плитки. Примечание об эпоксидных затирках: в отличие от цементных затирок, отвердевшие эпоксидные затирки можно удалить только механическим способом с риском повреждения поверхности плитки. Поэтому, излишки затирки необходимо удалять в свежем состоянии, в течение нескольких минут после ее нанесения и перед ее отвердеванием. Используйте электрический однощеточный полотер и чистую тряпку, смоченную в этиловом спирте. Часто меняйте тряпку. Независимо от того, какую именно затирку вы выбрали из перечисленных выше типов, следует обязательно и очень тщательно выполнять инструкции ее производителя в вопросах использования и дозировки разных компонентов.

Stucchi consigliati dalla normativa europea EN 13888

Grouts recommended by the EN 13888 european standard

Mortiers recommandés par la norme européenne EN 13888

Von der Europäischen Norm EN 13888 Empfohlene Fugenmasse

Затирки, рекомендуемые европейским стандартом EN 13888

| | |
|--------------------------------------------------------------------------------------------------------------------------------------------------------------------------------------------------------------------------------------------------------------------------------------------------------------------------------------------------------------------------------------------------------------------------------------------------------------------------------------------------------------------------------------------------------------------------------------------------------------------------------------------------------------------------------------------------------------------------------------------------------------------------------------------------------------------------------------|-----------------------------------------------------------------------------------------------------------------------------------------------------------------------------------------------------------------------------------------------------------------------------------------------------------------------------------------------------------------------------------------------------------------------------------------------------------------------------------------------------------------------------------------------------------------------------------------------------------------------------------------------------------------------------------------------------------------------------------------------------------------------------------------------------------------------------------------|
| <p>Destinazione d'uso Use Type d'application Gebrauchsbestimmung Назначение</p> | <p>Stucchi consigliati dalla normativa europea EN 13888 Grouts recommended by the EN 13888 european standard Mortiers recommandés norme européenne EN 13888, Von der Europäischen Norm EN 13888 Empfohlene Fugenmasse, Затирки, рекомендуемые европейским стандартом EN 13888</p> |
| <p>Ambienti interni residenziali Residential interiors Espaces résidentiels intérieurs Innenberemh in privaten Objekten Внутренние жилые помещения</p> | <p>Malte cementizie per fughe migliorate (Classe CG2 - EN 13888) Improved cementitious mortars for joints (Class CG2 - EN 13888) Mortiers à base de ciment pour joints ameliores a faible absorption d'eau (Classe CG2 W - EN 13888) Vergütele Fugenmörtel (Klasse CG2 - EN 13888) Улучшенные цементные растворы для швов (Класс 0G2 - EN 13888)</p> |
| <p>Ambienti umidi interni (bagni, docce, piscine...) ed ambienti esterni. Damp interiors (bathrooms, showers, swimming pools. ...) and outdoors. Espaces humndes intérieure (selles de bans, douches, piscines, etc.) et espaces exteneurs Nassräume im Innenbereich (Badezimmer, Duschen, Schwimmbecken...) und im Außenbereich Внутренние помещения с высокой влажностью (ванные, души, бассейны и т.п.) и открытые помещения</p> | <p>Malte cementizie per fughe migliorate con assorbimento d'acqua ridotto(Classe CG2 -W EN 13888) ottenute con aggiunta di opportuno additivo liquido. Improved cementitious mortars for joints with low water absorption (Class CG2 W - EN 13888) obtained with the addition of a suitable liquid additive. Mortiers à base de ciment pour joints ameliores a faible absorption d'eau (Classe CG2 W - EN 13888), obtenus par l'ajout d'un adjuvant liquide approprié. Zementäre Fugenmörtel mit verbesserten Eigenschaften und reduzierter Wasseraufnahme (Klasse CG2 W - EN 13888) engemecht mit spezieller Emulsion auf Dispersionsbasis. Улучшенные цементные растворы для швов с низким водопоглощением (Класс CG2 W - EN 13888) полученные добавлением жидкой добавки.</p> |
| <p>Ambienti ad uso commerciale Commerce premises Espaces a usage commercial Innenberemlmn gewerblichen Objekten Помещения коммерческого назначения</p> | <p>Malte cementizie per fughe migliorate con elevata resistenza all'abrasione (Classe CG2 AR - EN 13888) ottenute con aggiunta di opportuno additivo liquido. Improved cementitious mortars for joints with high resistance to abrasion (Class CG2 AR - EN 13888) obtained with the addition of a suitable liquid additive. Mortiers a base de ciment pour joints améliorés, hautement résistants a l'abrasion (Classe CG2 Ar - EN 13888) obtenus par l'ajout d'un adjuvant liquid approprié. Zementäre Fugenmörtel mit verbesserten Eigenschaften und hoher Abnebfestigkeit (Klasse CG2 Ar - EN 13888), engemecht mit spezieller Emulsion auf Dispersionsbasis. Улучшенные цементные растворы для швов с повышенной стойкостью к истиранию (Класс CG2 Ar - EN 13888) полученные добавлением жидкой добавки.</p> |
| <p>Ambienti in cui sia richiesta totale igiene e resistenza agli agenti chimici (piani di lavoro di cucine, industrie alimentari, ospedali, supermercati, ecc...) Premises requiring total hygiene and resistance to chemical agents (kitchen work surfaces, food industry, hosditals, supermarkets, etc) Espaces nécessitant une hygiène totale et une résistance aux agents chimiques (plans de travail de cuisines, industries alimentaires, hôpitaux, supermarchés, etc). Bereiche, in denen es auf absolute Hygiene und Chemikalienbeständigkeit ankommt (Arbeitsplatten in Küchen, Lebensmittelindustrie, Krankenhauser, Supermarkte). Помещения, где требуется полная гигиена и устойчивость к химическим агентам (рабочие столы на кухнях, пищевая промышленность, больницы, супермаркеты и т.п.)</p> | <p>Malte epossidiche (Classe RG - EN 13888) Epoxy mortars (Class RG - EN 13888) Mortiers epoxy (Classe RG - EN 13888) Epoxidharfugenmotel (Klasse RG - EN 13888) Эпоксидные строительные растворы (Класс RG - EN 13888)</p> |

La stesura dello stucco

Grouting - L'application du stuc

Auftrag der Fugenmasse - Нанесение затирки

Preparare l'impasto utilizzando acqua ed eventuali lattici (se si tratta di stucco in polvere) omogeneizzando il tutto meccanicamente. La boiaccia di stucco ottenuta deve essere spalmata in prossimità delle fughe tramite una spatola di gomma piatta o materiale plastico in modo da far penetrare bene lo stucco per tutta la profondità della fuga e per tutta la sua lunghezza in modo da evitare vuoti, o bolle d'aria. Terminata la stuccatura (trascorsi 10 min quando lo stucco inizia a opacizzare) rimuoverlo con spugna umida lo stucco in eccesso fuoriuscito in prossimità delle fughe in attesa che trascorrono 48 ore prima di effettuare la pulizia vera e propria per la quale si rimanda alla sezione "Pulizia finale dopo la posa in opera".

Prepare the mixture with water and latex (if you are using powder grout)and blend using mechanical equipment. The grout obtained must be spread into the joints using a flat rubber or plastic squeegee so that theproduct fills the joint leaving no gaps or air bubbles. After grouting (after 10 minutes, when the grout begins to

become opaque), remove any excess with a moist sponge. Wait 48 hours before performing accurate cleaning. See the "Final cleaning after installation" section.

Préparer le mélange avec de l'eau et d'éventuels latex (s'il s'agit de stucs en poudre) en mélangeant le tout mécaniquement. Étaler le mélange ainsi obtenu près des joints à l'aide d'une spatule en caoutchouc plate ou en plastique de manière à bien faire pénétrer le stuc sur toute la profondeur et la longueur du joint, ce qui permettra d'éviter la formation de vides ou de bulles d'air. Au terme du jointoiment (10 minutes après l'opacification du stuc), éliminer à l'aide d'une éponge humide le stuc en trop près des joints, puis attendre 48 heures avant d'effectuer un véritable nettoyage (voir le chapitre « Nettoyage final après la pose »).

Die Masse mit Wasser und eventueller Latex-Zugabe (bei Fugenmasse in Pulverform) anmachen und maschinell gleichmäßig verrühren. Die so erhaltene Fugenschlämme wird mit einer flachen Gummi- oder Kunststoffachtel in den Fugen verstrichen, so

dass sie gut und ohne Bildung von Hohlräumen oder Luftblasen über die ganze Tiefe und Länge in die Fuge eindringt. Nach dem Verfugen (nach 10 Min., wenn die Fugenmasse beginnt, matt zu werden) mit einem feuchten Schwamm die überschüssige Fugenmasse an den Fugenrändern entfernen. Bis zur eigentlichen Reinigung 48 Stunden abwarten (siehe hierzu den Abschnitt „Endreinigung nach der Verlegung“.

Подготовьте смесь, используя воду и при необходимости латекс (в случае применения порошковой затирки), равномерно смешивая компоненты механическими средствами. Полученную смесь затирки необходимо наносить рядом со швами при помощи гладкого резинового или гластмассового шпателя, обеспечивая хорошее проникновение затирки по всей глубине и длине шва, не допуская образования пустот или воздушных пузырей. Завершив нанесение затирки (спустя 10 минут, когда она начнет принимать матовый вид), удалите влажной губкой излишки затирки рядом со швами. Подождите 48 часов перед выполнением глубокой чистки, описанной в разделе "Конечная очистка после укладки".

Pulizia finale dopo la posa in opera

Final cleaning after installation - Nettoyage Curatif

Endreinigung nach der Verlegung - Конечная очистка после укладки

Dopo poche ore dalla stuccatura, non appena lo stucco inizia ad asciugare (opacizzare) spazzare il pavimento. Entro 48 h dalla stuccatura, comunque prima della completa maturazione e dell'indurimento dello stucco, bagnare il pavimento, con una soluzione acida ad azione tamponata, in percentuale di diluizione variabile in funzione del tipo di superficie (liscia o strutturata). Stendere uniformemente la soluzione con acido specifico per grès strofinando con un mop-lavapavimenti o con una mono spazzola rotante per grandi superfici dotata di dischi idonei all'uso e lasciare agire per qualche minuto. Risciacquare con acqua calda e stracci puliti, ripetendo l'operazione più volte sino all'eliminazione di ogni alonatura o traccia residua negli interstizi, avendo cura di cambiare spesso l'acqua di risciacquo. Terminare con una asciugatura. Prestare attenzione ad evitare il contatto della soluzione acida con materiali di altra natura (metalli, marmi etc).

ATTENZIONE!!: lo stucco epossidico non può essere più pulito quando il suo indurimento si è completato se non meccanicamente con rischi per la superficie delle piastrelle. Per ulteriori consigli e ragguagli rivolgersi al produttore dello stucco. Particolare cura deve essere usata per i prodotti incisi, levigati e antisdrucchiolo; per questi ultimi l'utilizzo di una spazzolatura, tipo lavapavimenti, in unione con l'azione acida aiuta ad arrivare in tutti gli interstizi della struttura facilitandone la pulizia. Se tale lavaggio non viene effettuato o effettuato tardivamente i residui di stucco che hanno creato un film cementizio estremamente assorbente, tendono a trattenere lo sporco facilitando la sporcabilità della superficie che può poi diventare difficile da pulire completamente:

in questi casi Ceramiche CAESAR S.p.A. declina ogni responsabilità.

A few hours after grouting, as soon as the grout starts to dry (it become opaque), sweep the floor. Within 48 hours from grouting and before the grout hardens definitively, wet the floor with an acid and buffered solution. Dilution depends on the type of surface (smooth or textured). Spread the solution containing acid especially made for stoneware using a mop or a rotary brush for large surfaces, and featuring suitable discs, and let the solution work for a few minutes. Rinse with warm water and clean cloths and repeat several times until all stains and residues have been eliminated. Make sure to change rinsing water several times. Complete by drying. Pay attention to prevent contact of the acid solution with other materials (metal, marble, etc.).

ATTENTION!! Epoxy-based grout cannot be cleaned when it has completely hardened other than mechanically with risks to the surface of the tiles. For more information and recommendations, consult the grout manufacturer. Care must be taken on inlaid, polished and anti-slip products; for the latter in particular, the use of a floor-washing machine combined with the action of an acid detergent helps reach the spaces between adjacent tiles and clean them properly. If such a cleaning procedure is not carried out, or if such cleaning is carried out too late, the grout residue creates an extremely absorbent film, which holds dirt, making the surface difficult to clean: in this case, Ceramiche CAESAR S.p.A. will not be liable for any damage caused to the surface.

Quelques heures après le jointoiment, balayer le carrelage dès que le stuc commence à sécher (s'opacifier). Au bout de 48 heures à compter du jointoiment, avant le séchage et le durcissement complets du stuc, mouiller le carrelage avec une solution acide tamponnée à diluer en fonction du type de surface (lisse ou structurée). Appliquer uniformément la solution acide en frottant à l'aide d'un balai à franges ou d'une monobrosse pour grandes surfaces et laisser agir quelques minutes. Rincer à l'eau chaude avec des chiffons propres à plusieurs reprises jusqu'à éliminer toutes les auréoles ou résidus au niveau des interstices, en prenant soin de changer souvent l'eau de rinçage. Terminer en laissant sécher. Éviter tout contact de la solution acide avec d'autres matériaux, quels qu'ils soient (métaux, marbres, etc.) ATTENTION : le stuc époxy ne peut plus être nettoyé lorsque son durcissement s'est complété si ce n'est mécaniquement avec les risques que cela comporte au niveau de la surface des carreaux. Un soin particulier doit être apporté aux produits gravés, polis et antidérapants. Pour ces derniers, le recours à un brossage pour le lavage des sols, combinée à l'action acide aide à atteindre tous les interstices de la structure et en facilite le nettoyage. Si ce lavage n'a pas lieu, ou s'il s'effectue trop tard, les résidus de joint qui créent une pellicule ciment extrêmement absorbante ont tendance à retenir les souillures et à faire en sorte que la surface se salisse plus vite et, par la suite, peuvent rendre plus difficile le nettoyage complet. Dans ce cas, Ceramiche CAESAR S.p.A. décline toute responsabilité.

Wenige Stunden nach dem Verfugen, sobald die Fugenmasse auszutrocknen beginnt (sie wird matt), den Bodenbelag kehren. Binnen 48 Std. nach dem

Verfugen und in jedem Fall vor dem vollständigen Abbinden und Aushärten der Fugenmasse den Boden mit einer sauren Pufferlösung befeuchten. Das Verdünnungsverhältnis variiert je nach Art der Oberfläche (glatt oder strukturiert). Die Lösung mit Speziälsäure für Feinsteinzeug gleichmäßig mit einem Wischmop oder bei großen Flächen mit einer Einscheibenmaschine verteilen und einige Minuten einwirken lassen. Mit warmen Wasser und sauberen Wischtüchern abspülen und den Vorgang mehrmals wiederholen, bis alle Flecken und Rückstände in den Zwischenräumen beseitigt sind. Das Spülwasser häufig wechseln. Zum Abschluss trocknen. Die Säurelösung darf nicht mit anderen Materialien (Metalle, Marmor etc.) in Kontakt kommen. Für weitere Tipps und Informationen wenden Sie sich bitte an den Hersteller der Fugenmasse. Besonderer Sorgfalt bedarf es bei geritzten, geschliffenen und rutschfesten Produkten; die letzteren sollten zur Erleichterung mit einer Bürste zusammen mit säurehaltigem Reinigungsmittel gereinigt werden, damit man auch in die Zwischenräume und Ritzen gelangt. Wird diese Reinigung nicht oder nur unzureichend durchgeführt, bilden die Rückstände einen Zementfilm mit hoher

Pulizia e manutenzione

Cleaning and care - Nettoyage et Entretien

Reinigung und Pflege - Чистка и уход

Se sono state rispettate le regole di pulizia dopo la posa, la manutenzione ordinaria, cioè la pulizia quotidiana per la rimozione dello sporco causato dal passaggio e dall'uso in generale della superficie piastrellata, è di ragionevole soluzione. Ricordiamo che il gres porcellanato è un prodotto le cui caratteristiche consentono di ottenere i massimi livelli di resistenza meccanica, all'usura, agli acidi (tranne l'acido fluoridrico ed i suoi derivati), e alle basi, caratteristiche a cui si aggiungono valori estetici di particolare rilievo. Il gres porcellanato mantiene un minimo assorbimento, e ciò costituisce la caratteristica intrinseca del prodotto. Nella produzione CAESAR, come indicato nella scheda tecnica, detto assorbimento è contenuto nei valori minimi assoluti e quindi per tutte le utilizzazioni dei nostri prodotti saranno raggiungibili i migliori risultati di impiego specifico. **La manutenzione ordinaria** dovrà essere fatta con

prodotti detergenti specifici per rimuovere sporco e macchie purché non siano ceranti, filmanti o pellicolanti. Consideriamo il risciacquo con acqua pulita fondamentale per un'ottima operazione di pulizia, per cui sconsigliamo l'utilizzo di prodotti con l'indicazione "non occorre il risciacquo". Prodotti in tinta unita chiara, ed in particolare il bianco e l'extrabianco, soprattutto nella versione levigata, lappata, lucidata e satinata pur essendo sempre pulibili dal punto di vista igienico, sono relativamente delicati rispetto a taluni tipi di macchia poiché, a volte, le stesse possono lasciare tracce o aloni più visibili che su prodotti meno chiari. Occorre pertanto tener presente che questi prodotti richiedono una manutenzione più impegnativa per la pulizia. I prodotti bianchi rispondono alla normativa vigente UNI EN ISO

assorbirender Eigenschaft und neigen dazu, den Schmutz zurückzuhalten. Damit wird es immer schwieriger, die Oberfläche vollständig und gründlich zu säubern: in diesen Fällen übernimmt Ceramiche CAESAR S.p.A. keine Haftung.

Через несколько часов после заполнения швов, как только затирка начнет высыхать (станет матовой), подметите пол. В течение 48 часов после заполнения швов, в любом случае перед полным созреванием и отвердением затирки, необходимо смочить пол кислотным раствором буферного действия, процент разведения которого меняется в зависимости от типа поверхности (гладкая или фактурная). Распределите равномерно раствор, содержащий специальную кислоту для керамогранита, протирая шваброй или, в случае обработки больших поверхностей, полотером со специальными дисками для этого применения, и оставьте на несколько минут. Смойте горячей водой и чистыми тряпками, повторяя операции несколько раз вплоть до устранения любых разводов или следов в щелях, часто меняя воду для смывания. В конце очистки

TECHNICAL DETAILS

вытрите насухо. Не допускайте попадания кислотного раствора на материалы другого типа (металл, мрамор и т.д.). ВНИМАНИЕ! После окончательного отверждения эпоксидную затирку можно удалить только механическими средствами с риском повреждения поверхности плитки. За дополнительными инструкциями и рекомендациями обратитесь к производителю затирки. Особенно внимательно следует выполнять чистку гравированных,полированных и противоскользящих плиток. Уборку последних может облегчить использование поломоечной машины, которая обеспечивает проникновение кислотного средства во все канавки или щели. Если данная чистка не производится или производится с запозданием, то оставшийся на поверхности облицовки тонкий слой цементной затирки будет способствовать лёгкому впитыванию грязи и, следовательно, повышенной загрязняемости; к тому же вполне вероятно, что поверхность больше не сможет быть очищена полностью. В этом случае Ceramiche CAESAR S.p.A. снимает с себя всякую ответственность.

remove stains but these detergents must not leave a wax, film or membrane residue. Rinsing well with plenty of clean water is a fundamental part of the cleaning procedure, therefore we advise against the use of products which state that they "do not need rinsing". Bright colored products, in particular white and extra-white tiles, especially those with a polished, honed and "lucidato" finish, are very delicate and, although for all intent and purpose are hygienically clean, they tend to stain more easily than darker tiles. It is therefore necessary to remember that these particular products require careful maintenance. White products meet the UNI EN ISO 14411 Annex G 10545-14 standard (calculation of stain resistance), for top quality materials in terms of cleanability: certain types of dirt need an extra-ordinary maintenance procedure using specific detergents according to the type of stain. We would like to inform you that, the above mentioned standards do not cover rubber stains (shoes, heels, mats, etc...) especially where these kinds of stains are frequent: therefore, Ceramiche CAESAR S.p.A. will not be held liable for any such damage to the surface of these products. All types of surface of the Caesar range can be washed with clean water or water and up to 50% of bleach or alcohol. We recommend periodical cleaning with basic products or a micro-foaming basic product for porcelain stoneware, followed by thorough rinsing and drying.

Si les règles de nettoyage après la pose ont été respectées, l'entretien ordinaire, c'est-à-dire le nettoyage quotidien pour l'élimination de la saleté causée par le passage et l'utilisation sur une surface carrelée, est simplifié. Nous rappelons que le grès

cérame est un produit dont les caractéristiques permettent d'obtenir les meilleurs niveaux de résistance mécanique à l'usure, aux acides (sauf l'acide fluorhydrique et ses dérivés) et aux bases et auxquelles s'ajoutent des valeurs esthétiques d'intérêt particulier. Ne s'agissant pas d'un produit émaillé, le grès cérame conserve une absorption minimum qui constitue la caractéristique intrinsèque du produit. Comme l'indique la fiche technique, dans la production Caesar, cette absorption est maintenue aux minimas absolus, ce qui signifie que pour n'importe quelle utilisation de nos produits, les résultats atteints seront les meilleurs pour cet emploi spécifique. L'entretien ordinaire doit s'effectuer avec des détergents spécifiques afin d'ôter le sale et les taches pour autant qu'il ne s'agisse pas de produits cirant, de pelliculant ou de produits créant une couche. Nous estimons que le rinçage à l'eau propre est fondamental pour un bon nettoyage, c'est pourquoi nous ne recommandons pas d'utiliser les produits qui «ne nécessitent aucun rinçage». Bien que les produits de teinte claire unie, le blanc et l'extra-blanc en particulier, surtout dans la version polie, "lappato", "lucidato" et satiné, soient lavables d'un point de vue hygiénique, ils sont relativement délicats à certains types de taches car il en est qui peuvent laisser des traces ou des auréoles qui se voient plus que sur les produits moins clairs. Il faut donc se souvenir que le nettoyage de ces produits demande plus d'effort pour l'entretien. Les produits blancs sont conformes à la norme en vigueur UNI EN ISO 14411 Annex G 10545-14 (Détermination de la résistance aux taches) valables pour les matériaux de premier choix en ce qui concerne leur capacité à être nettoyés. Certaines taches sales requièrent qu'un nettoyage extraordinaire soit effectué avec des détergents spécifiques pour ce type de taches. Nous attirons votre attention sur le fait que les normes citées n'incluent pas le nettoyage des traces de caoutchouc (chaussures, talons, pieds de chaises) en particulier pour les espaces où ces phénomènes sont plus probables et fréquents : c'est pourquoi Ceramiche CAESAR S.p.A. décline toute responsabilité sur ces produits. En ce qui concerne toutes les catégories de surfaces de la gamme Caesar, le nettoyage peut être effectué avec de l'eau propre ou de l'eau propre additionnée d'eau de javel ou d'alcool jusqu'à 50%. Il est conseillé d'effectuer des nettoyages périodiques avec du produit de base à micro-mousse pour grès cérame suivis par des phases de rinçage soigné et par le séchage.

Wurden die Hinweise zur Reinigung nach der Verlegung beachtet, so stellt die normale Reinigung, das heißt die Entfernung von Schmutz durch Begehung und Gebrauch der verfliesten Oberfläche,

Pulizia straordinaria

Extra-duty cleaning - Nettoyage et Entretien
Außerordentliche Reinigung - Внеплановая очистка

Al verificarsi di macchie o alonature di varia natura, si può intervenire per la loro rimozione senza grossi problemi in quanto il grès porcellanato è un materiale a assorbimento bassissimo, resistente agli acidi ed alle basi. A seconda del tipo di macchia possiamo intervenire con:
- ACIDO per macchie di natura INORGANICA,
- BASICO per macchie di natura ORGANICA,
- SOLVENTE per macchie di natura SINTETICA.

keine besonderen Probleme dar. Feinsteinzeug besitzt Eigenschaften, die maximale mechanische Beständigkeit, Abriebfestigkeit und Beständigkeit gegen Säuren (mit Ausnahme von Flusssäure und ihren Nebenprodukten) und Basen bieten. Dazu kommt ein hoher optischer Wert. Da das Produkt unglasiert ist, weist es eine minimale Absorption auf, was eine dem Produkt selbst innewohnende Eigenschaft darstellt. In der CAESAR-Produktion liegt, wie auf dem technischen Datenblatt angegeben, die besagte Absorption bei den absoluten Tiefstwerten, so dass mit unseren Produkten im jeweiligen Einsatzbereich beste Resultate erzielt werden können. Die normale Pflege sollte mit speziellen Reinigern und Fleckenentfernern erfolgen, die kein Wachs enthalten und nicht film- bzw. schichtbildend sind. Das Nachspülen mit sauberem Wasser ist für eine optimale Reinigung unerlässlich, daher raten wir vom Gebrauch von Produkten mit der Angabe: "Ohne Nachspülen" ab. Obwohl die hellen einfarbigen Produkte, dabei im Besonderen die weißen und extraweißen - vor allem in der geschliffenen, polierten, "lucidato" und Seidenmatt Ausführung - hygienisch zu reinigen sind, erweisen sie sich gegenüber einigen Arten von Flecken als relativ empfindlich. Diese hinterlassen auf ihnen hin und wieder sichtbare Spuren oder Ränder. Achten Sie daher darauf, daß diese Produkte besonders sorgfältig und regelmäßig gereinigt werden.

ACHTUNG!! Epoxy-Fugenmasse kann nur noch mechanisch gereinigt werden, wenn sie vollständig ausgetrocknet ist. Dabei besteht jedoch die Gefahr, die Fliesenoberfläche zu beschädigen. Die weißen Produkte entsprechen der geltenden europäischen Norm UNI EN ISO 14411 Annex G 10545-14 (Bestimmung der Fleckenbeständigkeit), gültig für Materialien erster Wahl in Bezug auf die Reinigung: besondere Flecken erfordern eine Behandlung und Reinigung mit - je nach Art der Flecken - speziellen Fleckenreinigern. Wir weisen jedoch darauf hin, daß die angegebenen Normen sich nicht auf die Reinigung und Entfernung von Gummispuren (von Schuhen, Absätzen, Stühlen etc.), vor allem in Bereichen, in denen diese Phänomene häufiger und wiederholt auftreten, beziehen: daher übernimmt Ceramiche CAESAR S.p.A. für diese Produkte keine Haftung. Alle Oberflächentypen des Caesar-Sortiments können mit klarem Wasser, mit Wasser und Bleiche oder mit bis zu 50 % mit Alkohol versetztem Wasser gereinigt werden. Wir empfehlen, eine periodische Reinigung mit einem basischen Produkt mit Mikroschaum für Feinsteinzeug vorzunehmen; anschließend gründlich nachspülen und trocknen.

Если были соблюдены правила очистки после

укладки, то без особых затруднений можно выполнять уход за плиткой, то есть, ежедневную уборку для удаления загрязнений, вызванных хождением и общим использованием керамической поверхности. Напоминаем, что керамогранит - материал, обладающий высочайшей механической прочностью, износостойкостью, устойчивостью к воздействию кислот (кроме фтористоводородной кислоты и ее производных) и щелочей, а также незаурядными эстетическими качествами. Однако неглазурованный керамогранит сохраняет минимальную поглощающую способность: это естественная характеристика материала. Изделия CAESAR, как видно из перечня технических характеристик, обладают самым низким коэффициентом водопоглощения, поэтому гарантируют отличные эксплуатационные показатели во всех условиях применения. Для ухода рекомендуется применение специальных чистящих средств, способных удалять грязь и пятна, при этом нельзя использовать средства на восковой основе или образующие защитную плёнку. Оптимальная чистка пола предполагает полоскание чистой водой, поэтому избегайте применения средств, не требующих ополаскивания. Следует учесть, что на однотонных светлых плитках, и в особенности на белых и экстрабелых или полированных, лапатированных, сатирированных и с финишной обработкой "lucidato" определённые типы загрязнений, более заметны, чем на менее светлых изделиях. По этой причине уход за такими плитками требует больших усилий. Изделия белого цвета соответствуют требованиям стандартов UNI EN ISO 14411, Приложение G, 1545-5 (определение стойкости к образованию пятен) в отношении изделий первого сорта. Некоторые типы загрязнений требуют экстренной чистки с применением специфических для конкретных пятен препаратов. Обращаем внимание на то, что указанные стандарты не рассматривают возможность удаления следов резины (от подошвы обуви, каблучков, резиновых наконечников стульев и т.п.), в частности, в помещениях, где подобные явления наиболее вероятны. Поэтому Ceramiche CAESAR S.p.A. отклоняет всякую ответственность в связи с этим. Все виды поверхности в производственном ассортименте Caesar можно мыть чистой водой, или водой с отбеливателем или спиртом в концентрации до 50%. Мы рекомендуем периодически выполнять уборку с использованием микропенного щелочного средства для керамогранита, которое затем следует тщательно смыть, после чего пол необходимо высушить.

macchie, e facilmente reperibili sul mercato, si rinvia alla tabella allegata.

Any stains or marks can be removed quite easily since porcelain stoneware has very low absorption properties and resists acids and bases. Depending on the type of stain, you can use:
- ACIDS for INORGANIC stains,
- BASES for ORGANIC stains,

TECHNICAL DETAILS

beiliegenden Tabelle zu entnehmen.

В случае образования пятен или разводов разного типа их можно удалить без особых проблем, так как керамогранит является материалом с очень низкой степенью водопоглощения и стойким к воздействию кислот и щелочей. В зависимости от типа пятна можно использовать:
- КИСЛОТУ на пятнах НЕОРГАНИЧЕСКОГО типа,
- ЩЕЛОЧЬ на пятнах ОРГАНИЧЕСКОГО типа,
- РАСТВОРИТЕЛЬ на пятнах СИНТЕТИЧЕСКОГО типа.
Настоятельно рекомендуется не использовать находящиеся в широкой продаже кислоты общего назначения (такие как соляная кислота), потому что они не только удаляют остатки затирки, но и непоправимо портят шов. Кроме того, рекомендуется остерегаться средств, СОДЕРЖАЩИХ ФТОРИСТОВОДОРОДНУЮ КИСЛОТУ (HF), ПОТОМУ ЧТО ОНА НЕПОПРАВИМО ПОВРЕЖДАЕТ ВСЕ КЕРАМИЧЕСКИЕ ПОВЕРХНОСТИ. Подходящие средства для удаления загрязнений разного типа, которые можно легко найти на рынке, смотрите в прилагающейся таблице.

- SOLVENTS for SYNTHETIC stains.
The use of common aggressive acids (such as muriatic acid for instance) must be avoided. These products remove residues of grout but also irreparably damage the grout within the joint. Also pay attention to all products containing HYDROFLUORIC ACID (HF) SINCE THEY IRREPARABLY DAMAGE ALL CERAMIC SURFACES. For information about products appropriate for the type of stain, which can be easily found on the market, refer to the following table.

Les éventuelles taches ou auréoles s'éliminent facilement étant donné que le grès cérame est un matériau à très faible absorption, qui résiste aux acides et aux bases. En fonction du type de tache, il est possible d'intervenir avec les produits suivants :
- ACIDE pour des taches de nature INORGANIQUE,
- BASIQUE pour des taches de nature ORGANIQUE,
- SOLVANT pour des taches de nature SYNTHÉTIQUE.
Il est fortement déconseillé d'utiliser des acides ordinaires (ex. : acide chlorhydrique) du fait qu'ils éliminent les résidus de stuc en détériorant irrémédiablement le joint. Faire en outre très attention aux produits À BASE D'ACIDE FLUORHYDRIQUE

(HF) ÉTANT DONNÉ QUE CET ACIDE ABÎME IRRÉPARABLEMENT TOUTES LES SURFACES CÉRAMIQUES. Pour une liste précise de produits convenant à la nature des tâches, et disponibles sur le marché, consulter le tableau suivant.

Flecken oder Ränder unterschiedlicher Art lassen sich einfach entfernen, da Feinsteinzeug nur extrem gering absorbierend und gegen Säuren und Basen beständig ist. Je nach Art der Flecken erfolgt die Reinigung mit:
- SÄURE bei durch ANORGANISCHE Substanzen bedingten Flecken,
- BASE bei durch ORGANISCHE Substanzen bedingten Flecken,
- LÖSEMittel bei durch SYNTHETISCHE Substanzen bedingten Flecken.
Von der Verwendung von Salzsäure wird dringend abgeraten, da diese nicht nur die Fugenmassenrückstände beseitigt, sondern auch die Fuge selbst irreparabel beschädigt. Darüber hinaus sind alle Produkte zu vermeiden, DIE FLUSSSÄURE (HF) ENTHALTEN, DA DIESE ALLE KERAMIKOBERFLÄCHEN IRREPARABEL BESCHÄDIGT. Die für die jeweiligen Flecken geeigneten, handelsüblichen Produkte sind der



Tabella esemplificativa

Illustrative table - Tableau indicatif

Beispiele für die Reinigung - Таблица с примерами

| Tipo di sporco Type of stain Type de salete Verschmutzung Тип загрязнения | Agente pulitore Cleaning agent Agent nettoyant Reinigungsmittel Чистящее средство | Detergenti Detergents Detergents Reinigung Моющие, Сред. Ства | Ditta produttrice detergente Detergent manufacturer Societe productrice de detergent Reinigungsmittel Herstellerfirma Фирма изготовитель моющего редства |
|---------------------------------------------------------------------------------------------------------------------------------------------------------------------------------------------------------------------------------------------------------------------------------------------------------------------------------------------------------------------------------------------------------------------------------------------------------------------------------------------------------------------------------------------------------------------------------------------------------------------------------------------------------------------------------------------------------------------------------|-----------------------------------------------------------------------------------------------------------------------|-------------------------------------------------------------------------------------------------------------------------------------------------------------------------------------------------|----------------------------------------------------------------------------------------------------------------------------------------------------------------------|
| MACCHIE INORGANICHE, INORGANIC STAINS, TACHES INORGANIQUES, ANORGANISCHE FLECKEN, ОРГАНИЧЕСКИЕ ПЯТИА | | | |
| Cemento *, Cement, Ciment, Zement, Цемент Carbone, Carbon, Charbon, Kohle, Уголь Effluorescenze calcaree, Calcium Efflorescence, Efflorescences calcaires, Kalk-Effloreszenzen, Известковые пятна Gesso, Chalk, Plâtre, Gips, Гипс Residui metallici, Metallic residues, Résidus Métalliques, Metallreste, Следы металла Ruggine, Rust, Rouille, Rost, Herrumbre Stucco cementizio *, Cement, based grout, Stuc de ciment-Zementmörtel, Цементная шпаклевка Stucco colorato *, Coloured grout, Stuc coloré, Farbiger Kitt, Цветная шпаклевка Tempere murali, Wall paint, Détrempe murales, Mauerfarben, Краска для стен | | Deterdek | Fila - via Garibaldi 32, 35137 Padova Tel. 049.9467300 |
| | Acida Acid Acid Säurehaltig Кислотный | Keramet (Liquido, Liquid Liquide, Flussing, Жидкость) | Mapei - via Cafiero 22, 20158 Milano Tel. 02.39320283 |
| | | Service Solvacid | GEAL by Bel Chimica Srl, Via Settola 121, 51031 Agliaiana (PT) - Tel. 0574 750365 |
| MACCHIE ORGANICHE, ORGANIC STAINS, TACHES ORGANIQUES, ORGANISCHE FLECKEN, ОРГАНИЧЕСКИЕ ПЯТНА | | | |
| Soca Cola, Кока-кола Gelato, Caffè, Vino, Birra, Ice Cream, Coffee, Wine, Beer Glace, Café, Vin, Bière-Eis, Kaffee, Wein, Bier, Мороженов, кофе, вино, пиво Grassi animali, Animal fats, Graisses animales, Tierische Fette, животные жиры Grassi vegetali, Vegetable fats, Graisses végétales, Pflanzliche Fette, Растительные жиры Mostarda, Maionese, Mustard, Mayonnaise, Moutard, Mayonnaise, Senf, Mayonnaise, Горчица, Майонез Ketch-up, Marmellata, Ketchup, Jam, Ketchup, Confiture Ketchup, Marmelade, Кетчуп, Варенье Olio di lino, Rossetto, Cera-Lineseed oil, lipstick, wax Huile de lin, Rouge à lèvres, Cire, Leinöl, Lippenstift, Wachs, Льняное Масло, Помада, Воск | | CHESTERTON 815 | Scati s.r.l. - via Radici in Piano Sassuolo (MO) Tel. 0536.804239 |
| | Alcalina e Neutra Alkaline and Neutral Alcaline et Neutre Alkalihaltig und Neutral Щелочной и Нейтральный | PS87 | Fila - via Garibaldi 32, 35137 Padova Tel. 049.9467300 |
| | | FILACLEANER | Fila - via Garibaldi 32, 35137 Padova Tel. 049.9467300 |
| | | SERVICE ALCALINE | GEAL by Bel Chimica Srl, Via Settola 121, 51031 Agliaiana (PT) - Tel. 0574 750365 |
| | | Ammoniaca - Ammonium Ammoniac - Ammoniak, Аммиак | Universale, Universal Universel, Universell, Универсальный |
| Aloni residui di natura organica Residual rings of organic nature Aureoles residuelles de nature organique Schmutzränder organischer natur Остатки органического характера | Soluzione Salina Saline solution Solution saline Salzlösung Солевой раствор | Ipoclorito di sodio (candeggina) Sodium hypochloride (bleach for white laundry) Hypochlorite de sodium (eau de javel) Natronbleichlauge (Bleicher) Гипохлорит натрия (отбеливатель) | Universale, Universal Universel, Universell, Универсальный |
| | | Service solvante | GEAL by Bel Chimica Srl, Via Settola 121, 51031 Agliaiana (PT) - Tel. 0574 750365 |
| Olii siliconati, Silicone oils, Huiles siliconées, Silikonöle, Силиконовые масла Olii meccanici, Machine oil, Huiles mécaniques, Mechaniköle, Машинные масла Resine e smalti, Resins and glazes, Résines et émaux, Harze und Lacks, Смолы и эмали Catrame e saucsiù-Coal and natural rubber-Goudron et saoutchouc, Teer und Kautschuk, Гудрон и каучук Inchiostri e lampostil, Inks and markers, Encres et feutures, Tinte und Faserschreiber, Чернила и фломастеры | Solvante Solvent Solvant Lösungsmittel Solvente | Filasolv | Fila - via Garibaldi 32, 35137 Padova Tel. 049.9467300 |
| | | Acetone, Aceton, Acetona, Ацетон | Universale, Universal, Universel, Universell, Универсальный |
| | | Diluente Nitro, Nitro, Thiner, Diluant Nitro, Nitroverdünner | Universale, Universal, Universel, Universell, Универсальный |
| | | Acquaragia, Turpentine Terebenthine, Terpentin, Скипидар | Universale, Universal, Universel, Universell, Универсальный |
| | | Trielina, trichlorethylene Trichloréthylène, trichloräthylen, Триэлин | Universale, Universal, Universel, Universell, Универсальный |
| Pneumatico, Tire, Pneu, Pneumatish, Шина | | Pasta lavamani, Hand Cleanser Pate Lave-Mains, Handwaschpaste | Universale, Universal, Universel, Universell, Универсальный |
| | | Cif ammoniacal | Universale, Universal, Universel, Universell, Универсальный |
| Silicone e chewin-gum, Silicone and chewin-gum, Silicone et chewin-gum, Silikon und Kaugummi, Силикон и жевательная резинка | | Ghiaccio + spatola, Ice+scraper Glacé+spatule, Eis+spachtel, Лед+шпатель | |

* Vedi modalità descritte alla sezione pulizia finale dopo la posa in opera. - See methods described in the Final cleaning after installation section. - Voir les modalités décrites au chapitre « Nettoyage final après la pose ». Siehe die Modalitäten im Abschnitt Endreinigung nach der Verlegung. - смотри указания, приведенные в разделе "Конечная очистка после укладки".

N.B: Per ulteriori informazioni sull'utilizzo dei detergenti contattare i nostri uffici. Nell'utilizzo dei prodotti sopraelencati si raccomanda di seguire le istruzioni d'uso indicate sulle confezioni. - For more information on use of detergents, contact our offices. When using the above products, the instructions on the package should be followed. - Pour de plus amples informations sur l'utilisation des détergents, contacter nos bureaux. Lors de l'utilisation des produits susmentionnés, il est recommandé de suivre les instructions pour l'emploi indiquées sur les emballages. - Für weitere Informationen zu den Reinigungsmitteln, bitten wir Sie sich mit unserer Verkaufsabteilung in Verbindung zu setzen. Bei der Verwendung der oben angeführten Produkte sollten Sie sich an die Gebrauchsanweisungen auf der Packung halten. - За дополнительной информацией по использованию моющих средств обращайтесь в нашу компанию. ПРИМ.: при использовании вышеперечисленных изделий рекомендуется следовать инструкциям, указанным на упаковке.

Classificazione per vizi

Fault classification - Classification par vices

Klassifizierung nach mängeln - Классификация дефектов

TECHNICAL DETAILS

| Vizi palesi - Visible faults - Vices apparents - Sichtbare Mängel - Явные дефекты | |
|-------------------------------------------------------------------------------------------------------------------------------------------------------------------------|-------------------------------------------------------------------------------------------------------------------------------------------------------------------------------------------------------------------------------------------------------------------------------------------------------------------------------------------------------------------------------------------------------------------------------------------------------------------------------------------------------------------------------------------------------------------------------------------------------------------------------------------------------------------------------------------------------------------------------------------------------------------------------------------------------------------------------------------------------------------------------------------------------------------------------|
| Causale - Reason Cause - Grund - Причина | Descrizione - Description Description - Beschreibung - Описание |
| Calibro - Caliber Calibre - Kaliber Калибр | Piastrelle di dimensioni (Larghezza/Lunghezza) differenti all'interno dello stesso lotto (Calibro/Caliber) con deviazioni superiori alle tolleranze rivendicate in scheda tecnica. Tiles with dimensions (width/length) that are different from those of tiles belonging to the same lot (Caliber), and with deviations above the tolerance ranges indicated in the technical data sheet. Carreaux de différentes dimensions (Largeur/Longueur) dans un même lot (Calibre/Caliber) avec des écarts supérieurs aux tolérances prévues sur la fiche technique. Fiesen mit unterschiedlichen Abmessungen (Breite/Länge) im selben Los (Kaliber), deren Abweichungen die auf dem Datenblatt angegebenen Toleranzen überschreiten. Плитка с разными размерами (ширины/длины) в одной партии (калибр), отклонения которых превышают заявленные в технических характеристиках допуски. |
| Planarità - Flatness Planéité - Ebenheit Плоскостность | Piastrelle concave o convexe (curvatura dello spigolo), con angoli rialzati o abbassati (svergolamento) con deviazioni superiori rispetto alle tolleranze rivendicate in scheda tecnica. Concave or convex tiles (corner curving), with corners curving up or down (warpage) and with deviations above the tolerance ranges indicated in the technical data sheet. Carreaux concaves ou convexes (courbure du bord), avec angles relevés ou rabaisés (gauchissement) avec des écarts supérieurs aux tolérances prévues sur la fiche technique. Konkave oder konvexe Fiesen (gekrümmte Kante) mit erhöhten oder abgesenkten Ecken (Verdrehung), deren Abweichungen die auf dem Datenblatt angegebenen Toleranzen überschreiten. Вогнутая или выпуклая плитка (искривление граней) с приподнятыми или опущенными углами (перекосом), отклонения которых превышают заявленные в технических характеристиках допуски. |
| Ortogonalità, rettilineità Squareness, straightness of sides Orthogonalité, Rectitude - Rechtwinkligkeit, Geradlinigkeit - Прямоугольность, Прямолинейность | Piastrelle con lati non rettilinei e non ortogonali ("effetto trapezio") con deviazioni superiori rispetto alle tolleranze rivendicate in scheda tecnica. Tiles with sides that are not straight and that do not form a square ("trapezoid effect"), with deviations above the tolerance ranges indicated in the technical data sheet. Carreaux avec des côtés non rectilignes et non orthogonaux (« effet trapèze ») avec des écarts supérieurs aux tolérances prévues sur la fiche technique. Fiesen mit nicht geradlinigen oder nicht rechtwinkligen Seiten ("Trapezeffekt"), deren Abweichungen die auf dem Datenblatt angegebenen Toleranzen überschreiten. Плитка с отклонениями сторон от прямоугольности и прямолинейности ("эффет трапеции"), отклонения которых превышают заявленные в технических характеристиках допуски. |
| Spessore - Thickness Épaisseur - Stärke Толщина | Piastrelle con spessore differente all'interno della stessa scatola con deviazioni superiori rispetto alle tolleranze rivendicate in scheda tecnica. Tiles with a different thickness with respect to the other tiles in the same box, with deviations above the tolerance ranges indicated in the technical data sheet. Carreaux présentant différentes épaisseurs dans une même boîte avec des écarts supérieurs aux tolérances prévues sur la fiche technique. Fiesen unterschiedlicher Stärke in derselben Schachtel, deren Abweichungen die auf dem Datenblatt angegebenen Toleranzen überschreiten. Плитка разной толщины в одной и той же коробке, отклонения которой превышают заявленные в технических характеристиках допуски. |
| Crepe - Cracks Fissures - Risse Трещины | Piastrelle con crepe parallele o ortogonali al bordo oppure superficiali con immediato distacco di placche superficiali dopo battitura. Tiles with cracks that are parallel to or at a right angle with the edges, or surface cracks resulting in immediate detachment of chips after tapping. Carreaux présentant des fissures parallèles ou orthogonales par rapport au bord ou sur la surface avec décollement immédiat de plaques superficielles après tapotement. Fiesen mit parallelen oder lotrechten Rissen an der Kante bzw. an der Oberfläche und Ablösung der Oberflächenschicht unmittelbar nach dem Ankopfen. Плитка с трещинами, расположенными параллельно или перпендикулярно краю, либо поверхностными с немедленным отсоединением кусков поверхности после простукивания. |
| Sbeccature - Chipping Ébrèchures - Angeschlagene Kanten - Сколы | Piastrelle con angoli e/o bordi rotti dentro alle scatole. Tiles in boxes, which feature broken corners and/or edges. Carreaux avec angles et/ou bords cassés dans les boîtes. Fiesen mit beschädigten Ecken und/oder Kanten in den Schachteln. Плитка в коробках имеет поврежденные углы и/или крошки. |
| Difetti superficiali - Surface defects Défauts de surface - Oberflächendefekte Поверхностные дефекты | Piastrella con buchi, spillature, crateri, vulcani, avvallamenti, inquinamento di impasto e presenza della marca (impressa dal retro del materiale ceramico) sulla superficie di esercizio. Tiles with holes, pinholes, craters, bumps, contaminated bodies and tile bottom face appearing on the top face. Carreaux avec trous, piquages, bulles, crateres, affaissements, pollution de la pâte et présence de la marque (imprimé au dos du matériel céramique) sur la surface praticable. Fiese mit Löchern, Nadelstichen, Kratern, Vulkanen, Beulen, verschmutztem Scherben und an der Vorderseite durchgedrücktem Markenzeichen (auf der Rückseite eingepresst). На рабочей поверхности плитки присутствуют вмятины, наколы, кратеры, выбоины, примеси и просвечивание рисунка тыльной (монтажной) стороны плитки на лицевой поверхности. |
| Difetti di decorazione Decorating Defects Défaut de décoration - Dekorationsfehler Дефект декорирования | Piastrelle con difetti di serigrafia, di smalto, gocce, righe della digitale. Tiles with screen-printing or glazing defects, drips, stripes resulting from digital decoration. Carreaux avec des défauts de sérigraphie, d'émail, gouttes, rayures. Fiesen mit Siebdruck- oder Glasurfehlern, Tropfen, Linien aus dem Digitalverfahren. Плитка с дефектами шелкографии и глазури, потеками, полосами, оставленными при нанесении цифрового декора. |
| Fuori tono - Tiles outside the tone range Imperfections chromatiques - Fehlfarbe Разнотон | Piastrelle con tono eccessivamente diverso dal riferimento e/o campione fornito al cliente. Tiles with too many "holes", colour surfacing out from the body, scratched and/or opaque edges, semi-circular surface scratches. Carreaux avec une couleur différente par rapport à celle de référence et/ou de l'échantillon fourni au client. Fiesen mit übermäßig vom Bezugston und/oder dem Kunden gelieferten Muster abweichendem Farbton. Плитка, тон которой слишком заметно отличается от эталонного и/или от предоставленного клиентом образца. |
| Toni mescolati - Mixed tones Tons mélangés - Farbmixfehler Смешение тона | Piastrelle all'interno della stesso lotto con un grado di stonazione superiore al V-Shade riportato a catalogo. Tiles that form splinters, flakes, breaks after linear cuts and/or square and/or round drilling. Carreaux d'un même lot avec un niveau de variabilité chromatique supérieure à V-Shade indiqué sur le catalogue. Fiesen mit stärkeren Farbschwankungen als der im Katalog angegebenen V-Shade Klasse in derselben Schachtel. Плитка одной производственной партии имеет степень цветовой неоднородности, превышающую указанный в каталоге класс V-Shade. |
| Difetti di lappatura/levigatura Honing/polishing defects Défaut de polissage - Läpp- Polierfehler - Дефект притирки-шлифовки | Piastrelle con "bucatura" eccessiva, "pelate" (affioramento del colore dell'impasto), bordi graffiati e/o opachi, graffi superficiali di forma semicircolare... Tiles with too many "holes", colour surfacing out from the body, scratched and/or opaque edges, semi-circular surface scratches. Carreaux avec « piqués » excessives, « bandes » (affleurement de la couleur du mélange), bords rayés et/ou opaques, rayures superficielles semi-circulaires, etc. Fiesen mit übermäßigen Löchern oder Abriebstellen (Farbe des Scherbens scheint durch), verkratzen und/oder matten Kanten, halbrunden Kratzern an der Oberfläche... У плитки обнаруживаются потертости, проплевшины (выступание цвета смеси), царапины и/или матовые края, поверхностные царапины полукруглой формы... |
| Problemi da taglio, scaglie Cutting problems, flakes Problèmes de découpe, écailles - Schnittfehler, Splitter - Проблемы, вызванные резкой - Сколы | Piastrelle che si scagliano, scagliano, rompono durante il taglio lineare e/o foratura quadrangolare e/o circolare. Tiles that form splinters, flakes, breaks after linear cuts and/or square and/or round drilling. Carreaux qui s'ébrèchent, s'écaillent, se cassent durant la découpe linéaire et/ou le perçage quadrangulaire et/ou circulaire. Fiesen, die beim linearen Schneiden und/oder beim rechteckigen oder runden Ausbohren absplittern oder brechen. Плитка раскалывается, расслаивается, разбивается при выполнении линейной резки и/или прямоугольных или круглых отверстий. |
| Vizi occulti - Hidden faults - Vices cachés - Verborgene Mängel - Скрытые дефекты | |
| Causale - Reason Cause - Grund - Причина | Descrizione - Description Description - Beschreibung - Описание |
| Crepe, scatology, sfilato Cracks, surface cracks Fissures - Risse - Hohlräume - Feiner Haarriss - Трещины На Поверхности Или Краях | Piastrelle che successivamente alla posa manifestano crepe parallele o ortogonali al bordo oppure superficiali ("scatology"). Tiles on which cracks parallel to or at a right angle with the edges appear or tiles on which surface cracks appear. Carreaux présentant, après la pose, des fissures parallèles ou orthogonales par rapport au bord, ou bien superficielles. Fiesen, die nach der Verlegung parallele oder lotrechte Risse an der Kante bzw. an der Oberfläche aufweisen (Hohlraum). После укладки плитка обнаруживает трещины, расположенные параллельно или перпендикулярно краю, либо на поверхности. |
| Cavillo tardivo - Late crazing Défaut tardif - Nachträglicher Haarriss Позднее образование кракелюра | Piastrelle smaltate da rivestimento che manifestano fenomeni di cavillo "tardivo" dopo alcuni mesi dalla posa in opera. Glazed wall tiles on which "late" crazing appears a few months after installation. Carreaux de revêtement émaillés présentant des défauts « tardifs », c'est-à-dire quelques mois après la pose. Glasierete Wandfliesen, an denen einige Monate nach der Verlegung Haarrisse entstehen. Глазурованная облицовочная плитка обнаруживает позднее образование кракелюра через несколько месяцев после укладки. |
| Danneggiamento da gelo Damage due to frost Détérioration par le gel - Frostschäden Повреждения от мороза | Piastrelle che dopo alcuni mesi dalla posa in esterno mostrano la comparsa di fratture e scagliature abbastanza tipiche della ceramica, il più delle volte di tipo "concoide". Tiles on which cracks and flaking appear a few months after outdoor installation. These are quite typical of ceramics and are of the "concoide" type. Carreaux présentant, quelques mois après la pose en extérieur, des fractures et des écailles typiques de la céramique, surtout « conchoïdales ». Fiesen, die einige Monate nach der Verlegung im Freien die für Keramik recht typischen, meist muschelförmigen Brüche und Absplittungen aufweisen. Спустя несколько месяцев после укладки на улице на плитке обнаруживаются характерные для керамики поломки и сколы, в большинстве случаев в виде спиральных линий. |
| Macchiabilità - Easy staining Taches - Verfleckung Маркость | Piastrelle che trattengono in modo anormale lo sporco e risultano essere di difficile pulibilità. Tiles that withhold dirt in an abnormal manner and that are difficult to clean. Carreaux difficiles à nettoyer du fait qu'ils retiennent la saleté de façon anormale. Fiesen, die auf anormale Weise Schmutz anziehen und sich nur schwer säubern lassen. Плитка аномально впитывает грязь и трудно очищается. |

Avvertenza

Warning - Avertissement

Hinweis - Предупреждение

Sia sul nostro catalogo generale, a pag. 462, sia sul sito vengono spiegati in maniera esaustiva gli argomenti per guidare gli addetti alla posa a mantenere un atteggiamento corretto in fase di posa del materiale al fine di garantirne la durabilità nel tempo. Durante la fase di posa è necessario operare in un ambiente pulito e sgombro da materiali non necessari all'operazione, come ad esempio gli imballi vuoti di cartone delle piastrelle che dovranno essere smaltiti in modo sostenibile posizionandoli in una benna o altro contenitore in modo da essere destinati alla raccolta di riciclo della carta. Per le grandi lastre, le casse in legno e i cavalletti dovranno essere restituiti alla nostra azienda o presso isole ecologiche che trattano questo materiale (ormai quasi tutte).

Inoltre a pag. 472 viene dedicato ampio spazio sia per la prima pulizia dopo la posa sia per la pulizia straordinaria delle superfici, e vengono anche forniti consigli sulla manutenzione ordinaria che non prevede l'utilizzo di prodotti da banco o da scaffale che, nella loro formulazione potrebbero contenere sostanze ceranti, pellicolanti, ecc. che non devono essere adoperate sul gres porcellanato in quanto non in grado di assorbirle e quindi creando una patina superficiale che si sporca con molta facilità e che per la sua rimozione comporterebbe l'uso di sostanze aggressive. L'utilizzo di semplice candeggina diluita in acqua è più che sufficiente a mantenere pulita la superficie, in quanto l'ipoclorito di sodio è un buon detergente ma anche un buon igienizzante.

Nei casi di ristrutturazioni di ambienti che prevedano la sostituzione delle pavimentazioni preesistenti e dei rivestimenti, il materiale di risulta deve essere conferito presso ditte specializzate nella raccolta e riciclaggio dei materiali edili in modo che non vengano abbandonati nell'ambiente, ma conferiti a ditte che lo raccolgono e lo trattano in modo sostenibile nei confronti dell'ambiente.

I suggerimenti illustrati in precedenza sono frutto di ricerca, verifica di laboratorio ed esperienza pluriennale. Tuttavia le caratteristiche di pulibilità dei materiali variano in modo significativo per le diverse modalità d'installazione, condizioni d'uso, tipologie di superfici e ambiente. In linea generale, all'aumentare delle caratteristiche di antiscivolosità delle piastrelle aumentano le difficoltà di pulizia. L'operatore professionale incaricato dell'intervento di manutenzione e pulizia dovrà sempre procedere ad una preliminare verifica empirica (possibilmente su una porzione di materiale non posato) per ogni singolo tipo di intervento. In caso di condizioni d'uso particolarmente gravose (ad esempio, officine meccaniche o ambienti con forte presenza di residui oleosi e tracce di pneumatico), di errata installazione o di pulizie effettuate in modo inadeguato, Caesar declina ogni responsabilità in merito all'efficacia delle operazioni di pulizia e manutenzione. Resta inteso che Caesar non può essere ritenuta

responsabile per eventi, danni o difetti dovuti ad errata installazione, negligente pulizia e manutenzione, o inadeguata scelta della tipologia dei materiali installati e degli adesivi utilizzati con riguardo alla destinazione.

Both in our general catalogue, on page 462, and on our website, we explain in detail what is needed to guide the installers to maintain a correct attitude when installing the material, in order to ensure its durability over time. During the installation phase, work must be carried out in a clean environment, free from materials not necessary for the operation, such as empty cardboard tile packaging, which must be disposed of in a sustainable manner by placing it in a bucket or other container so that it can be sent for the recycling collection of paper. For large slabs, wooden crates and stands must be returned to our company or to waste separation areas that handle this material (now almost all of them).

Also on page 472, great consideration is dedicated to both initial cleaning after installation and extraordinary cleaning of surfaces, as well as advice on routine maintenance which does not involve the use of regular counter or shelf products. Their formulation may contain waxing, film-forming substances, etc. which must not be used on porcelain stoneware as it is unable to absorb them; they may create a surface patina which is very easily stained and requires the use of aggressive substances to remove. The use of simple bleach diluted in water is more than sufficient to keep the surface clean, as sodium hypochlorite is a good detergent but also a good sanitiser.

In the case of room renovations involving the replacement of existing floor and wall tiles, the waste material must be taken to companies specialised in the collection and recycling of building materials so that it is not abandoned in the environment, rather given to companies that collect and treat it in a sustainable manner.

The above suggestions are a result of research, laboratory tests and several years' experience. However, the cleaning features of the materials may vary significantly according to the different installation methods, conditions of use, types of surface and destination. As a general rule, the higher the anti-slip values of the tiles are, the greater cleaning inconveniences may arise. The professional operator in charge of maintenance and cleaning shall always check the surface condition before proceeding with any cleaning and/or maintenance operation (we would suggest to test some tiles before installation). Caesar declines any liability with reference to cleaning and maintenance operations in case of heavy conditions of use (such as mechanical workshop or spaces presenting oily residues or tyre marks), bad installation work or wrong cleaning operations, it is agreed that Caesar shall not be liable for any event, damage or defect due to wrong installation of the tiles,

faulty cleaning and maintenance operations or inadequate choice of the type of material to be laid or of the adhesives used in a certain destination of use.

Notre catalogue général, en page 462, ainsi que notre site, expliquent de manière exhaustive les thèmes nécessaires à guider les personnes chargées de la pose afin qu'elles adoptent un comportement adéquat durant la pose du matériel afin d'assurer sa durabilité. La phase de pose doit être effectuée dans un environnement propre et dépourvu de matériel inutile aux opérations, comme les emballages de carton vides qui contenaient les carreaux ; ceux-ci devront être éliminés de manière responsable et déposés dans une benne ou tout autre conteneur de collecte du matériel destiné au recyclage du papier. Pour les grandes dalles, les caisses en bois et les chevalets devront être retournés à notre entreprise ou déposés dans une déchetterie qui traite ce matériel (presque toutes actuellement).

Toujours à la page 472, une grande place est accordée au premier nettoyage après la pose et au nettoyage extraordinaire des surfaces ; des conseils sont également fournis quant à l'entretien ordinaire qui ne prévoit pas l'utilisation de produits de comptoir ou d'étagère dont la composition pourrait contenir des substances cireuses ou pelliculantes, etc. qui ne doivent pas être utilisées sur le grès cérame puisqu'il n'est pas en mesure de les absorber, ce qui génère une pellicule superficielle qui se salit très rapidement ; dans ces cas, son nettoyage pourrait donc requérir des substances agressives. La simple utilisation d'eau de javel diluée dans de l'eau est plus que suffisante pour assurer la propreté de la surface, puisque l'hypochlorite de sodium est un bon produit nettoyant, mais aussi désinfectant. Dans le cas des rénovations d'environnements qui prévoient le remplacement des sols et revêtements existants, le matériel retiré doit être confié à des entreprises spécialisées dans la collecte et le recyclage de matériel de construction, afin qu'ils ne soient pas abandonnés dans la nature mais confiés à des entreprises qui le collectent et le traitent de manière respectueuse de l'environnement.

Les suggestions ci-dessus reportées sont le résultat d'une expérience qui s'étend sur plusieurs années de recherches et de vérifications en laboratoire. Toutefois, les caractéristiques de nettoyabilité des carreaux varient considérablement en fonction des différentes modalités de pose, des conditions d'utilisation, ainsi que de la finition de surfaçage et des locaux. En général, le nettoyage devient plus difficile au fur et à mesure qu'augmente la capacité antidérapante et anti-glissante du carreau. Le responsable chargé de l'entretien et du nettoyage devra toujours procéder au préalable à une vérification empirique (si possible sur une quantité de matériel non posée) pour toute sorte d'intervention. En cas de

conditions d'utilisation particulièrement dures (comme par exemple: ateliers de mécanique ou en présence consistante de résidus huileux et traces de pneus), d'une pose non correcte ou de nettoyages inappropriés et non adéquats, Caesar décline toute responsabilité quant à l'efficacité des opérations de nettoyage et d'entretien. Il reste entendu que Caesar ne pourra être en aucun cas retenue responsable pour des dommages ou défauts dû à une pose non correcte, à un nettoyage inapproprié ou à un entretien négligent, ainsi qu'au choix inadéquat du type de produit posé et des matériaux de pose utilisés par rapport à la destination du produit.

Sowohl in unserem Gesamtkatalog auf Seite 462 als auch auf der Website werden alle Aspekte erläutert, um den Fliesenleger zu korrektem Arbeiten anzuleiten. Damit wird eine lange Lebensdauer des Materials garantiert. Während der Verlegung ist es wichtig, dass der Raum sauber ist und frei von jeglichen, nicht für die Verlegung erforderlichen Materialien wie beispielsweise leere Fliesenschachteln. Diese sind nachhaltig zu entsorgen, etwa in einem Kübel oder in einem anderen Behälter, um dem Papierrecycling zugeführt zu werden. Die Holzkisten und Böcke der großen Platten sind an uns zurückzugeben oder zu Müllsammelstellen zu bringen, die dieses Material aufbereiten (das sind inzwischen fast alle).

Ebenfalls auf Seite 472 sind ausführlich die Erstreinigung nach der Verlegung sowie die außerordentliche Reinigung der Beläge beschrieben, sowie Tipps zur normalen Pflege. Für diese sind keine handelsüblichen Produkte zu verwenden, da sie Wachs- oder filmbildende Substanzen etc. enthalten könnten; diese sind nicht für Feinsteinzeug geeignet, das sie von diesem nicht absorbiert werden. Das würde zur Entstehung einer Patina an der Oberfläche führen, die leicht verschmutzt und sich nur mit aggressiven Reinigungsmitteln wieder entfernen lässt. Einfache, in Wasser verdünnte Bleiche genügt völlig, um den Belag sauber zu halten, denn Kaliumhypochlorit ist nicht nur ein guter Reiniger, sondern auch ein gutes Desinfektionsmittel.

Bei der Renovierung von Räumen, in denen der auch der vorhandene Boden- und/oder Wandbelag ersetzt wird, ist der Abfall durch Fachbetriebe für Sammlung und Recycling von Bauschutt zu entsorgen, damit dieser nicht unkontrolliert in die Umwelt gelangt, sondern ökologisch nachhaltig aufbereitet wird. Die obenstehenden Empfehlungen basieren auf Forschungsergebnissen, Laboruntersuchungen und langjährigen Erfahrungen. Die Reinigungsfähigkeit des Materials variiert jedoch je nach Verarbeitung, Nutzungsbedingungen, Oberflächentypologien sowie Umgebung deutlich. Für gewöhnlich nimmt mit der Rutsicherheit der Fliesen auch der Schwierigkeitsgrad der Säuberung zu. Der

ausgebildete Handwerker, der mit der Wartung und Säuberung betraut wird, sollte stets vor Arbeitsbeginn einen Probeversuch (möglichst auf einem kleinen Stück nicht verlegten Materials) durchführen. Bei schwierigen Einsatzbereichen, z. B. Kfz-Werkstätten oder in Bereichen mit starker Ölverschmutzung und Reifenspuren, bei falscher Verarbeitung oder bei unsachgemäßer Reinigung weist Caesar jegliche Verantwortung in Bezug auf die Wirksamkeit der Reinigung und Wartung zurück. Es versteht sich, daß Caesar nicht für Ereignisse, Schäden oder Mängel belangt werden kann, die durch unsachgemäße Verarbeitung, durch nicht durchgeführte Reinigung und Wartung oder durch falsche Auswahl der verwendeten Materialien sowie durch Einsatz ungeeigneter Klebstoffe verursacht werden.

В нашем общем каталоге на странице 462, а также на нашем сайте можно найти исчерпывающие рекомендации для специалистов по укладке, которые помогут использовать правильный подход при укладке материала, что позволит добиться максимальной долговечности. Укладку следует производить в чистом помещении, освобожденном от ненужных материалов, например, пустой картонной упаковки от плитки. Упаковку следует утилизировать экологичным способом, выкинув ее в специальный контейнер для бумаги. Деревянные ящики и пирамиды, используемые для перевозки крупногабаритных плит, следует вернуть нашей компании или сдать на соответствующую площадку для сбора вторсырья (в настоящее время такой вид отходов принимают почти на всех площадках). Также на странице 472 размещен большой раздел с рекомендациями по первой чистке после укладки и по генеральной уборке керамогранитных поверхностей. Там также приводятся советы по текущему обслуживанию, которое не предусматривает использование полирующих средств, открыто представленных в торговых сетях, которые содержат в составе восковые, пленкообразующие и другие компоненты. Такие средства не следует наносить на керамогранит, так как данный материал не способен их впитывать. Таким образом, на поверхности плитки образуется налет, который быстро загрязняется, а для его удаления могут потребоваться агрессивные чистящие средства. Простого водного раствора отбеливателя достаточно для поддержания чистоты поверхности, поскольку гипохлорит натрия является хорошим чистящим и дезинфицирующим средством.

В случаях проведения реставрационных работ, требующих замены покрытия пола, строительный мусор следует сдавать в организации, специализирующиеся на сборе и переработке строительных материалов,

чтобы избежать загрязнения окружающей среды.

Проиллюстрированные выше рекомендации являются плодом лабораторных исследований и многолетнего опыта. Степень очищаемости материалов варьирует в зависимости от способа укладки, от условий эксплуатации, от типа поверхности и среды. Обычно чем выше сопротивляемость плиток скольжению, тем труднее их чистить. Профессиональные работники, занимающиеся обслуживанием и чисткой, перед выполнением любого типа операций должны осуществить практическую проверку материала (желательно на неуложенном изделии). В случае особо тяжёлых условий эксплуатации (например, в автомастерских или в помещениях, где часто образуются масляные пятна или остаются следы шин), а также в случае неправильной укладки или неправильно выполненной послеукладочной чистки Caesar снимает с себя любую ответственность относительно эффективности последующих действий по чистке и уходу. Компания Caesar равным образом не несёт ответственности за происшествя, ущерб или дефекты, обнаружившиеся по причине неправильной укладки и чистки, небрежного обслуживания или ошибочного – по отношению к функциональному назначению – выбора типа изделий и клея.



Project Evolution

Extended beauty

Note tecniche

Technical information - Notes techniques

Technische auskünfte - Техническая Характеристика

Informazioni generali

General information - Informations générales

Allgemeine Hinweise - Общая информация.

Le lastre Caesar nei formati 160x320 cm (spessore 6 mm), 120x278 cm (spessore 6 mm), sono prodotti in grès porcellanato, rettificati, quadrati e monocalibro, realizzati nel rispetto delle normative EN ISO 14411 ISO 13006 annesso G gruppo B1A in materia di prestazioni tecniche.

Caesar slabs in sizes 160x320 cm (6 mm thick), 120x278 cm (6 mm thick), are made of porcelain stoneware that is rectified and wedged and has a single size grade. As far as technical performance is concerned, they are manufactured in compliance with the EN ISO 14411 ISO 13006 Annex G standards for group B1A material.

Les dalles Caesar aux formats 160x320 cm (épaisseur 6 mm), 120x278 cm (épaisseur 6 mm), sont des produits en grès cérame, rectifiés, équarris et monocalibre, réalisés conformément aux normes EN ISO 14411, ISO 13006 annexe G groupe B1A en matière de performances techniques.

Die Caesar-Platten in den Formaten 160x320 cm (Stärke 6 mm), 120x278 cm (Stärke 6 mm), werden aus Feinsteinzeug hergestellt. Sie sind rektifiziert, perfekt rechteckig und haben ein Einheitskaliber. Die technischen Leistungen entsprechen den Normen EN ISO 14411, ISO 13006 Anhang G, Gruppe B1A.

Плиты Caesar в форматах 160x320 см (толщина 6 мм), 120x278 см (толщина 6 мм), – это обрезные изделия из керамогранита с прямыми гранями, одного калибра, которые производятся в соответствии со стандартом EN ISO 14411 ISO 13006, приложение G, с техническими характеристиками из группы B1A.

Imballaggio

Packaging - Emballage

Verpackung - Упаковка

Le lastre Project Evolution non vengono inscatolate ma disposte sfuse all'interno di casse oppure su cavalletti. Per maggiori dettagli, si rimanda al Manuale Tecnico Project Evolution.

Project Evolution slabs are not boxed but rather arranged loose inside crates or on trestles. For more details, please refer to the Project Evolution Technical Manual.

Les plaques Project Evolution ne sont pas emballées dans un carton, mais elles sont disposées en vrac dans des caisses ou sur des chevalets. Pour de plus amples détails, veuillez consulter le manuel technique Project Evolution.

Die Project Evolution-Platten werden nicht in Kartons verpackt, sondern lose in Kisten oder auf Böcke gelegt. Ausführlichere Informationen finden Sie im technischen Handbuch von Project Evolution

Trasporto e scarico

Transportation and unloading - Transport et Déchargement

Transport und Abladung - Транспортировка и Разгрузка.

Nella fase di trasporto, Caesar raccomanda di non sovrapporre pallet di altro tipo alle casse contenenti questi prodotti. Inoltre si raccomanda di utilizzare muletti e forche di dimensioni idonee alla movimentazione dei pallet appena descritti. Per le casse delle lastre 160x320 cm si consiglia in ogni caso di allargare le forche al massimo, per fare presa sulla maggior superficie possibile della cassa: in caso di presa dal lato corto, si consiglia l'utilizzo di forche che abbiano almeno lunghezza 2800 mm.

During transport, Caesar recommends you not to stack other types of pallet onto the cases containing these products. It is also recommended to use elevator and forklift trucks of dimensions that are suitable for handling the above mentioned pallets. For cases containing 160x320 cm slabs, it is recommended to widen the forks as far as is possible in order guarantee effective support of the case: if you are lifting the case from its short side, it is recommended to use forks with a length of at least 2800 mm.

Caesar recommande de ne pas superposer, durant le transport, d'autres types de palettes sur les caisses contenant ces produits. Il est en outre recommandé d'utiliser des chariots élévateurs et des fourches aux dimensions appropriées au transport des palettes susmentionnées. Il est de toute façon conseillé, pour les caisses des dalles de 160x320 cm, d'écarter les fourches au maximum de manière à optimiser la préhension : pour saisir les palettes du côté court, il est conseillé d'utiliser des fourches d'au moins 2800 mm de long.

Caesar empfiehlt, während des Transports keine anderen Palettentypen auf die Paletten mit diesen Produkten zu legen. Außerdem sind für den Umschlag der oben beschriebenen Paletten ausreichend große Hubwagen und Gabeln zu verwenden. Für die Kisten mit 160x320 cm großen Platten empfiehlt sich in jedem Fall, die Gabeln so weit wie möglich auseinanderzustellen, um die Kiste möglichst großflächig abzustützen: zur Aufnahme von der kurzen Seite sollten wenigstens 2800 mm lange Gabeln benutzt werden.

TECHNICAL DETAILS

Плиты Project Evolution не упаковываются в картон, а поставляются поштучно в деревянных ящиках или на стойках. Для получения более подробной информации, пожалуйста, обратитесь к Техническому руководству по Project Evolution.

Verifica del materiale

Checking of contents - Vérification du Matériel
Prüfung des Materials - Проверка Материала.

Il posatore è sempre tenuto a controllare il materiale prima della posa, standendo a terra alcune lastre e verificando accuratamente la corrispondenza del prodotto alle specifiche tecniche e le caratteristiche estetiche d'insieme, accertandosi anche dell'integrità delle lastre; si rammenta che non si prenderanno in considerazione contestazioni per lastre posate aventi difetti visibili.

Fitters must always check material before installation, by placing a few slabs on the floor and making sure that they correspond to specifications both technical and aesthetic. Fitters should also ensure that the slabs are in good condition; please remember than any

complaints relating to visible faults on slabs that have been installed will not be taken into consideration.

Le poseur doit toujours contrôler le matériel avant la pose en positionnant quelques dalles sur le sol et en vérifiant soigneusement la conformité du produit aux caractéristiques techniques et esthétiques générales ainsi que le bon état des dalles ; à noter qu'il ne sera pas tenu compte de contestations concernant des dalles posées malgré la présence de défauts visibles.

Der Fliesenleger muss das Material stets vor der Verlegung kontrollieren. Hierzu einige Platten auf den Boden legen und sorgfältig überprüfen, ob das Produkt den technischen Vorgaben und dem

gewünschten optischen Gesamteindruck entspricht. Dabei ist auch die Unversehrtheit der Platten zu kontrollieren; Reklamationen von mit sichtbaren Fehlern verlegten Platten werden nicht akzeptiert.

Плиточник всегда обязан проверять материал перед его укладкой, разложив несколько плит на полу и тщательно проверяя, что изделия соответствуют техническим характеристикам и общему эстетическому виду, а также удостоверяясь в целостности плит. Обращаем ваше внимание на то, что не принимаются претензии по уложенным плитам с заметными дефектами.

Movimentazione delle lastre in cantiere

Handling of the slabs on the work site - Manutention des Dalles sur le Chantier
Bewegung der Platten auf der baustelle - Обращение с Плитами на Стройплощадке.

Le lastre di Project Evolution raggiungono dimensioni e pesi considerevoli, che rendono necessari alcuni accorgimenti per garantire la sicurezza degli operatori e evitare possibili rotture delle lastre stesse. Pertanto, per la movimentazione in cantiere e la successiva posa in opera, Caesar consiglia l'utilizzo di attrezzature idonee, tra cui un apposito telaio di movimentazione, dotato di ventose per il sollevamento delle lastre ed eventualmente anche di carrello con ruote per il trasporto, adeguato a trasportare pesi consistenti (circa 83 kg più il peso del collante per le lastre 160x320). Si raccomanda di prestare particolare attenzione durante le fasi di spostamento della singola lastra: l'estesa superficie impone l'uso di opportuna cautela onde evitare rotture in conseguenza di urti o eccessive flessioni. In particolare, per i formati 160x320 e 120x278 è necessario che l'estrazione delle lastre dalla cassa e la movimentazione in cantiere siano eseguite da almeno quattro operatori qualificati. Ciò nel rispetto delle normative locali vigenti in materia di salute e sicurezza sul luogo del lavoro, riguardanti sollevamento di pesi considerevoli e dimensioni poco maneggevoli; l'utilizzo di un telaio dotato di braccia telescopiche facilita l'estrazione delle lastre poste anche sul fondo della cassa.

Project Evolution slabs have considerable dimensions and weight. This means that some precautions must be taken to guarantee safe work and avoid breakage of the slabs. For handling and subsequent installation, Caesar recommends the use of suitable equipment, namely a special handling frame, featuring suction cups for lifting the slabs, and, if necessary, a trolley with wheels for transporting heavy weights (approx. 83 kg plus the weight of the adhesive for 160x320 slabs). It is recommended to pay particular attention during movement of each single slab: owing to the considerable dimensions, be particularly careful in order to prevent breakage caused by collision of excessive bending. In particular, for sizes 160x320 and 120x278, it takes at least four qualified operators to take the slab out of

the case and move it in the work site area. All operations must be performed in compliance with the local standards for health and safety at work, in particular those relating to handling of heavy weights and particularly troublesome sizes; the use of a frame with telescopic arms facilitates extraction of the slabs at the bottom of the case.

Les dalles de Projet Evolution atteignent des dimensions et des poids considérables qui nécessitent certaines mesures afin de garantir la sécurité des opérateurs et d'éviter toute casse. Par conséquent, Caesar conseille, pour la manutention sur place et la pose, d'utiliser des équipements appropriés, notamment un châssis (muni de ventouses pour le levage des dalles et, éventuellement, d'un chariot sur roues pour le transport), en mesure de transporter des charges lourdes (environ 83 kg plus le poids du mortier-colle pour les dalles 160x320). Il est recommandé d'accorder la plus vive attention au déplacement de chaque dalle : étant donnée leur surface importante, il faut faire très attention pour éviter toute casse due à des flexions ou à des chocs excessifs. Notamment, pour les formats 160x320 et 120x278, il faut faire appel à au moins quatre ouvriers qualifiés afin de sortir les dalles de la caisse et de les manutentionner ensuite sur le chantier. Cet engagement est garanti par l'observance de la réglementation en vigueur en matière de santé et de sécurité sur le travail et en ce qui concerne le levage de charges très lourdes et difficiles à manipuler ; l'utilisation d'un châssis muni de bras télescopiques facilite l'extraction des dalles se trouvant au fond de la caisse.

Die Project Evolution Platten sind sehr groß und schwer. Zur Gewährleistung der Sicherheit des Personals und um das Brechen der Platten selbst zu vermeiden, sind daher einige Vorkehrungen erforderlich. Für den Umschlag auf der Baustelle und die anschließende Verlegung empfiehlt Caesar die Verwendung geeigneter Vorrichtungen. Dazu zählen ein spezieller Transportrahmen mit Saugnapfen zum Anheben der Platten, und ggf. auch ein Rollwagen, der geeignet ist, hohe Lasten zu transportieren (bei Verlegung der 160x320 großen Platten circa 83 kg sowie das Gewicht des Klebers). Während

TECHNICAL DETAILS

der Bewegung der einzelnen Platten ist besondere Vorsicht geboten, um angesichts ihrer Größe durch Stöße oder übermäßiges Biegen bedingte Brüche zu vermeiden. Vor allem für die Formate 160x320 und 120x278 sind zur Entnahme der Platten aus der Palette und zur Bewegung auf der Baustelle wenigstens vier qualifizierte Personen erforderlich. Unabhängig davon sind die örtlichen Vorschriften zur Sicherheit und zum Gesundheitsschutz am Arbeitsplatz hinsichtlich der Anhebung von unhandlichen, hohen Lasten und Abmessungen einzuhalten; die Verwendung eines Rahmens mit Teleskoparmen erleichtert die Entnahme auch der am Palettenboden liegenden Platten.

В силу больших размеров и веса плиты Project Evolution требуют соблюдения определенных мер предосторожности во избежание травмирования работников и разбивания самих плит. Поэтому, для их перемещения по стройплощадке и в процессе укладки Caesar рекомендует использовать подходящее оборудование, в том числе специальную раму с присосками для подъема плит, а при необходимости их перевозки – также тележку на колесах, пригодную для перевозки значительных грузов (около 83 кг, плюс вес клея в случае с плитами 160x320). Мы рекомендуем быть крайне внимательными при выполнении операций перемещения отдельных плит: ввиду большой поверхности необходимо принятие специальных мер предосторожности во избежание поломок, вызванных ударами или чрезмерным изгибом. В частности, для форматов 160x320 и 120x278 необходимо, чтобы извлечением плит из ящиков и перемещением по строительной площадке занимались не менее четырех квалифицированных рабочих. Операции должны выполняться с соблюдением местных правил в области безопасности труда и охраны здоровья при подъеме тяжелых и крупногабаритных грузов; использование рамы с телескопическими рычагами облегчает извлечение плит, даже если они лежат на самом дне ящика.

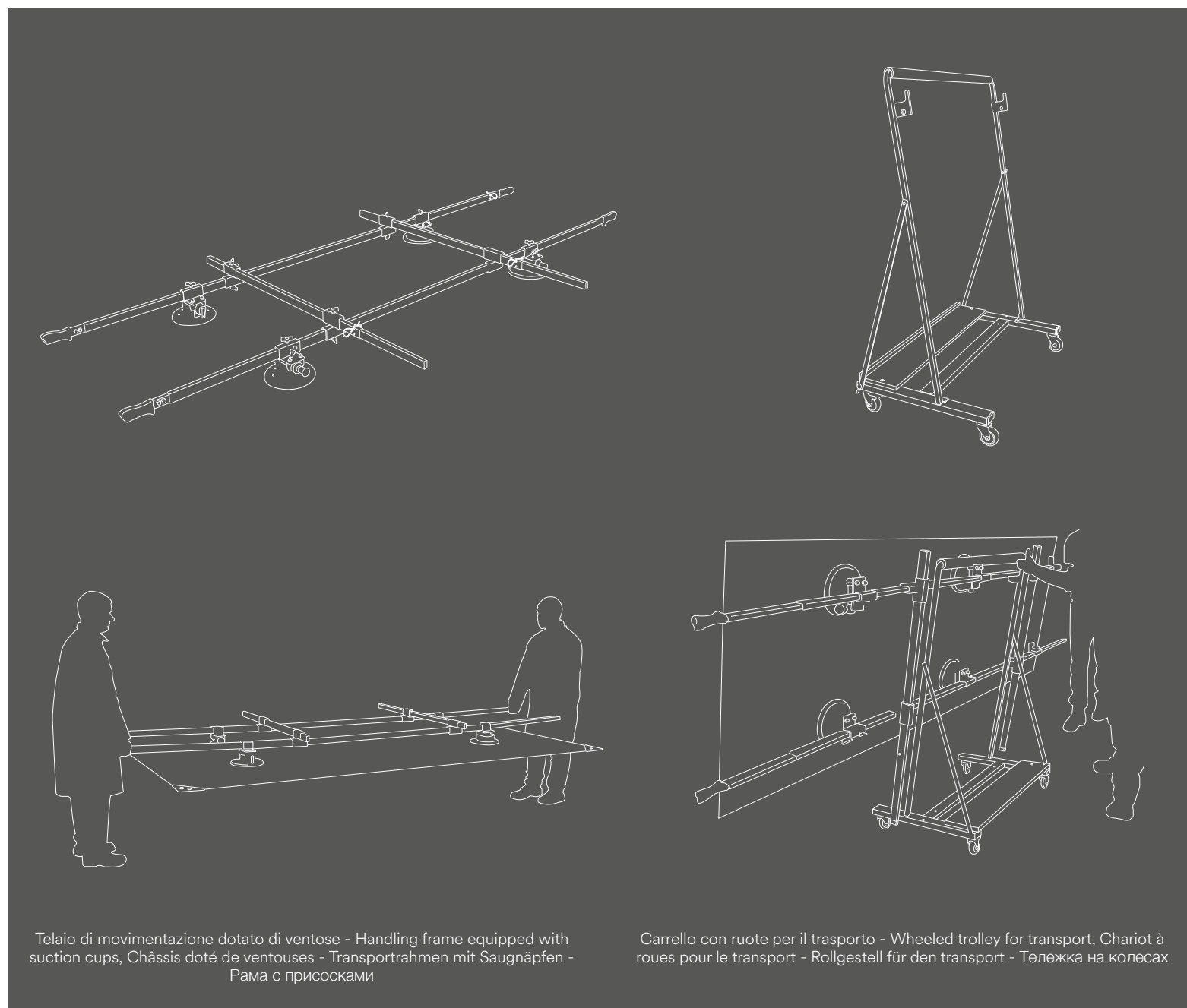

Telaio di movimentazione dotato di ventose - Handling frame equipped with suction cups, Châssis doté de ventouses - Transportrahmen mit Saugnapfen - Рама с присосками

Carrello con ruote per il trasporto - Wheeled trolley for transport, Chariot à roues pour le transport - Rollgestell für den transport - Тележка на колесах

Tagli e fori

Cutting and drilling - Découpes et Perçages
Schnitte und Bohrungen - Резка и Сверление.

Per effettuare tagli e fori, Caesar consiglia di posizionare la lastra su un banco da lavoro o superficie piana in materiale non scivoloso.

- Taglio lineare: le lastre Caesar in formato 160x320 cm, 120x278 cm, possono essere tagliate con l'ausilio di una guida da taglio con carrello incisore dotata di ventose, una pinza troncatrice e un tampone diamantato. Si consiglia di posizionare le lastre sulla guida da taglio, segnare gli estremi della porzione da asportare e poi procedere con la tracciatura, avendo cura di bloccare la guida per il taglio con le apposite ventose di cui è dotata. Nella fase di incisione, è opportuno iniziare con due incisioni di circa 5 cm alle due estremità della lastra, procedendo dall'interno verso l'esterno: si può poi effettuare il grosso dell'incisione congiungendo questi due segmenti. Dopodiché, si esegua la troncatura con l'ausilio della pinza troncatrice, avendo sempre cura di iniziare il lavoro partendo dalle due estremità. Infine è consigliabile smussare il bordo tagliato con l'ausilio di un tampone diamantato. Nel caso di tagli lineari molto vicini al bordo si può operare con una smerigliatrice opportunamente fissata alla guida.

- Jollatura: anche la jollatura può essere eseguita come il taglio lineare vicino al bordo, avendo cura di inclinare la smerigliatrice secondo l'angolo desiderato.

- Tagli ad L: per questa lavorazione si consiglia l'impiego di una smerigliatrice provvista di disco diamantato e di un foretto diamantato per foratura ad umido. È opportuno iniziare con il foretto, eseguendo un foro del diametro di 7/8 mm al vertice dell'area da rimuovere e proseguire con la smerigliatrice, facendo due incisioni di circa 5 cm alle due estremità della medesima area; si conclude congiungendo foro e incisione, operando dal centro verso l'estremità.

- Fori rettangolari: analogamente ai tagli ad L, le strumentazioni necessarie sono la smerigliatrice provvista di disco diamantato e il foretto diamantato

per foratura ad umido. Prima del taglio, è importante utilizzare il foretto per eseguire fori di diametro 7/8 mm nei punti alle estremità della zona di taglio. Si può poi concludere il lavoro congiungendo i fori tramite la smerigliatrice con disco diamantato.

- Fori: si può forare il materiale servendosi di avvitatore e foretti diamantati per foratura a umido (frese a tazza), avendo sempre cura di inumidire la superficie durante il foro. A foro effettuato si consiglia di rifinire la superficie con l'ausilio di una smerigliatrice provvista di disco diamantato.

Lista dell'equipaggiamento per movimentazione, tagli e fori:

- telaio di movimentazione, dotato di ventose per il sollevamento delle lastre ed eventualmente anche di carrello con ruote per il trasporto;
- banco da lavoro adatto ai formati in questione;
- guida da taglio con carrello incisore;
- pinza troncatrice;
- tampone diamantato;
- smerigliatrice provvista di disco diamantato;
- foretto diamantato per foratura a umido (fresa a tazza);
- avvitatore.

To cut and drill a slab, Caesar recommends you to place the slab on a work bench or flat surface made of non-slip material.

- Straight cuts: Caesar slabs of sizes 160x320 cm, 120x278 cm, can be cut using a cutting guide with engraving trolley featuring suction cups, cutting-off pliers and a diamond pad. Place the slab on the cutting guide, establish the contour of the portion to remove and trace it out, making sure to lock the cutting guide in place using the special suction cups it is fitted with. During engraving, it is recommended to start with two engravings of about 5 cm, at the two ends of the slab.

During engraving, it is recommended to start with two engravings of about 5 cm, at the two ends of the slab.

Proceed moving from the inside to the outside; you can then complete engraving by joining these two segments. Now perform splitting using pliers. Make sure to begin your work starting from the two ends. It is then recommended to smooth the cut edge using a diamond pad. In the event of straight cuts close to the edge, it is possible to use an angle grinder, which must be appropriately secured to the guide.

- Corner cutting: corner cutting can be performed in the same manner described for straight cuts close to the edge. Make sure to position the angle grinder based on the corner cut to perform.

- L-shaped cuts: for this type of work, use an angle grinder with a diamond disc and a diamond tool for wet drilling. Start by drilling a hole with a diameter of 7/8 mm, near to the portion to remove. Continue your work using the angle grinder. Provide two engravings of about 5 cm at the two ends of the same portion. Complete by joining the hole to the engraving. Work moving from the centre to the end.

- Rectangular holes: as described for L-shaped cuts, the tools needed are an angle grinder with diamond disc and a diamond tool for wet drilling. Before cutting, use the diamond tool to drill holes with a diameter of 7/8 mm in the points at the ends of the cutting area. You can complete your work by joining the holes using the angle grinder with diamond disc.

- Holes: you can drill material by using a screwdriver and diamond tools for wet drilling (cutting discs). During drilling, make sure that the area involved in kept wet. Once the hole has been completed, finish off the surface with an angle grinder with diamond disc.

List of equipment for handling, cutting and drilling:

- frame for handling featuring suction cups for lifting the slab and, if necessary, trolley for transport;
- work bench of a suitable size;

- cutting guide with engraving trolley;
- cutting off pliers;
- diamond pad;
- angle grinder with diamond disc;
- diamond tool for wet drilling (cutting disc);
- screwdriver.

Pour percer les dalles, Caesar conseille de les positionner sur un établi de travail ou sur une surface plane non glissante.

- Découpe linéaire : Il est possible de découper les dalles Caesar au format 160x320 cm, 120x278 cm, à l'aide d'un guide de découpe avec chariot incisore équipé de ventouses, d'une pince coupante et d'un tampon diamanté. Il est conseillé de positionner les dalles sur le guide de découpe, de marquer les extrémités de la portion à éliminer et de tracer en ayant soin de bloquer le guide de découpe à l'aide de ses ventouses. Il convient durant la phase d'incision d'effectuer tout d'abord deux incisions d'environ 5 cm aux deux extrémités de la dalle de l'intérieur vers l'extérieur : unir ensuite ces deux segments pour compléter l'incision. Découper ensuite à l'aide de la pince coupante en ayant toujours soin de commencer par les deux extrémités. En dernier lieu, il est conseillé de limer le bord à l'aide d'un tampon diamanté. En cas de découpes linéaires très proches du bord, il est possible d'utiliser une ponceuse dûment fixée au guide.

- Marquage : le marquage peut lui aussi être réalisé comme la découpe linéaire à côté du bord, en veillant à incliner la ponceuse selon l'angle voulu.

- Découpes en L : pour cet usinage, il est conseillé d'utiliser une ponceuse munie d'un disque diamanté et un foret diamanté pour perçage par voie humide. Commencer avec le foret en perçant un trou de 7/8 mm de diamètre au sommet de la partie à éliminer puis poursuivre avec la ponceuse, en réalisant deux

incisions de 5 cm environ aux deux extrémités de la même partie ; terminer en rejoignant le perçage et l'incision en procédant du milieu vers l'extrémité.

- Perçages rectangulaires : de même que pour les découpes en L, il faut une ponceuse équipée d'un disque diamanté et d'un foret diamanté pour perçage par voie humide. Il est important, avant la découpe, d'utiliser le foret pour réaliser des trous d'un diamètre de 7/8 mm aux points indiqués à l'extrémité de la zone de découpe. Terminer le travail en joignant les trous à l'aide de la ponceuse à disque diamanté.

- Perçages : Il est possible de percer le matériau à l'aide d'une visseuse et de forets diamantés pour perçage par voie humide (fraises creuses), en ayant soin de mouiller la surface durant le perçage. Une fois le trou percé, il est conseillé de parfaire la surface à l'aide d'une ponceuse à disque diamanté.

Équipement nécessaire pour la manutention, les découpes et les perçages :

- châssis doté de ventouses pour le levage des dalles et, le cas échéant, chariot sur roues pour le transport ;
- établi de travail adapté aux formats usinés ;
- guide de découpe avec chariot incisore ;
- pince coupante ;
- tampon diamanté ;
- ponceuse à disque diamanté ;
- foret diamanté pour un perçage par voie humide (fraises creuses) ;
- visseuse.

Zum Schneiden und Bohren der Platten empfiehlt Caesar, die Platte auf einen Arbeitstisch oder auf eine ebene Fläche aus rutschfestem Material zu legen.

- Gerader Schnitt: Die Caesar-Platten in den Formaten 160x320 cm, 120x278 cm, lassen sich mit einer Führungsschiene und Ritzschlitten mit Saugnäpfen, einer Trennzange und einem

Schleifkissen zuschneiden. Es empfiehlt sich, die Platten an der Führung zu positionieren, die Enden des abzuschneidenden Teils zu markieren und dann die Schnittlinie anzureißen. Die Führungsschiene ist dabei mit den Saugnäpfen zu blockieren. Beim Ritzen sollte mit zwei circa 5 cm langen, von innen nach außen geführten Schnitten an den beiden Plattenenden begonnen werden: anschließend werden diese beiden Schnitte durch Einritzen verbunden. Nun werden die Plattenteile mit der Trennzange getrennt, wobei wiederum an den beiden Enden begonnen wird. Schließlich sollte die geschnittene Kante mit einem Schleifkissen angefasst werden. Für sehr nahe an der Kante befindliche, gerade Schnitte kann eine entsprechend an der Führung befestigte Schleifmaschine verwendet werden.

- Jollyschnitt: Auch der Jollyschnitt kann wie der gerade Schnitt in Kantennähe ausgeführt werden. Dabei ist darauf zu achten, die Schleifmaschine mit dem gewünschten Winkel zu neigen.

- L-Schnitt: Für diese Bearbeitung empfehlen sich eine Schleifmaschine mit Diamantscheibe und ein Diamantnassbohrer. Beginnen Sie mit dem Diamantnassbohrer und führen Sie eine Bohrung mit 7/8 mm Durchmesser an der Spitze des zu entfernenden Bereichs aus. Mit der Schleifmaschine zwei ca. 5 cm lange Einschnitte an den beiden Enden desselben Bereichs ausführen und dann Bohrung und Einschnitt von der Mitte bis zum Ende hin verbinden.

- Rechteckige Aussparungen: Erfolgen wie die L-Schnitte mit einer Schleifmaschine mit Diamantscheibe und einem Diamantnassbohrer. Es ist wichtig, vor dem Schnitt mit dem Diamantnassbohrer Löcher mit 7/8 mm Durchmesser an den Enden des Schnittbereichs auszuführen. Zum Abschluss des Vorgangs werden diese Bohrungen mit der Schleifmaschine mit Diamantscheibe verbunden.

- Bohrungen: Das Material kann mit einem

TECHNICAL DETAILS

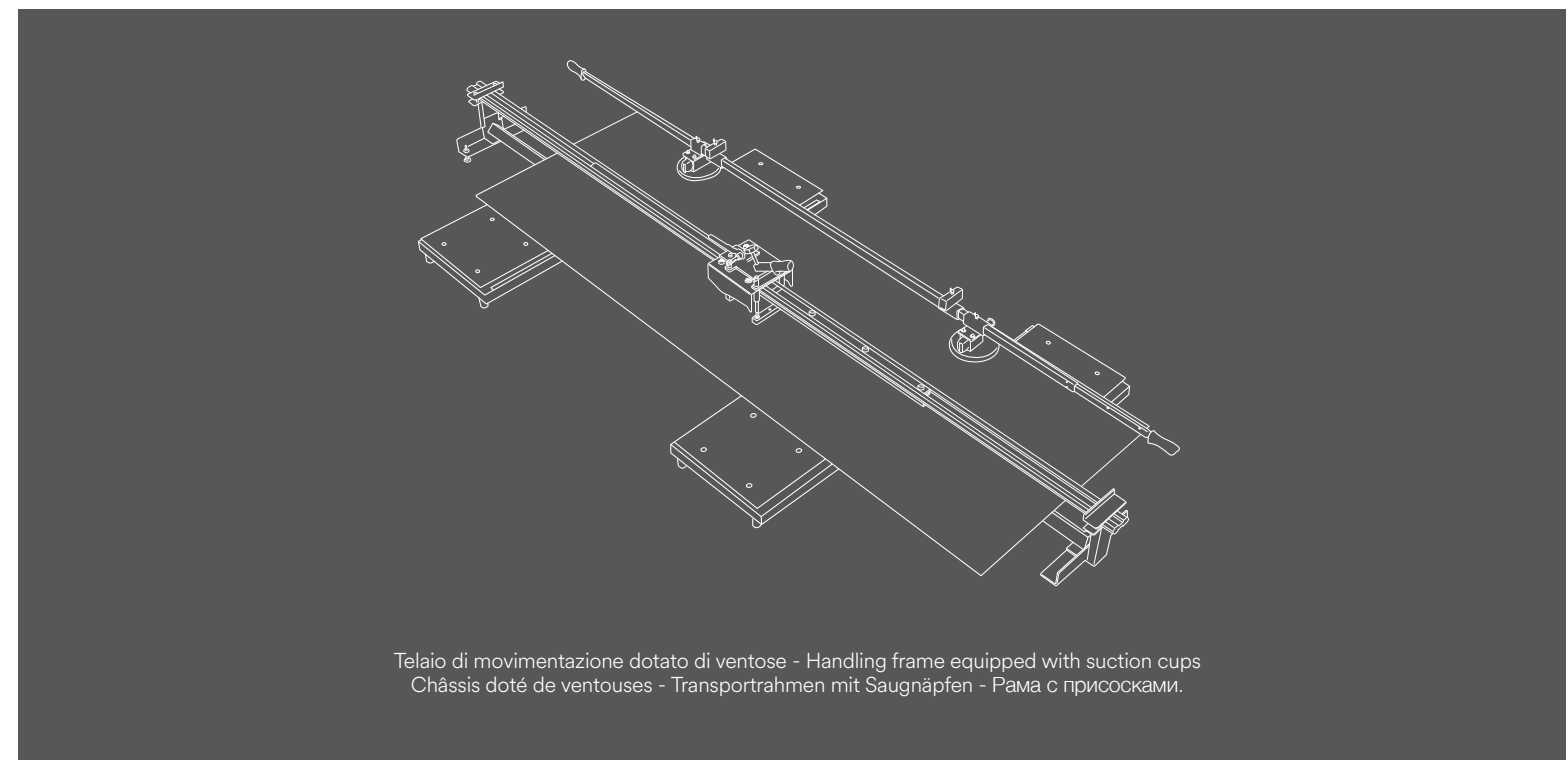
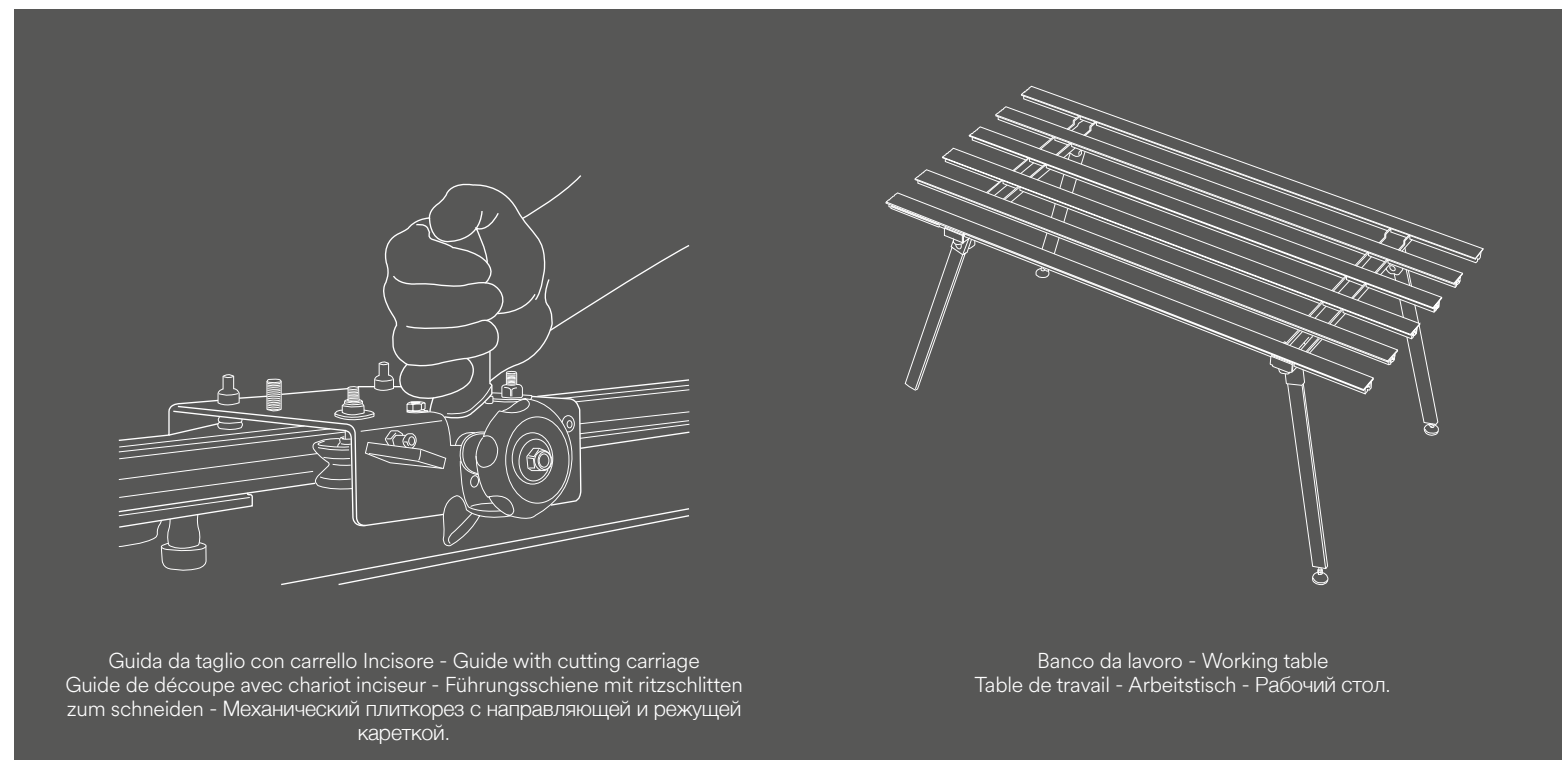

Schrauber und Diamantnassbohrern (Hohlfräser) gebohrt werden, wobei die Oberfläche während des Bohrens stets zu befeuchten ist. Nach dem Bohren sollte die Oberfläche mit einer Schleifmaschine mit Diamantscheibe nachbearbeitet werden.

Ausrüstung für Bewegung, Schnitte und Bohrungen:

- Transportrahmen mit Saugnäpfen zum Anheben der Platten, und ggf. Rollwagen für den Transport;
- für die Formate geeigneter Arbeitstisch;
- Führungsschiene mit Ritzschlitten zum Schneiden;
- Trennzange;
- Schleifkissen;
- Schleifmaschine mit Diamantscheibe;
- Diamantnassbohrer (Hohlfräser);
- Schrauber.

Для резки и сверления материала Caesar рекомендует поместить керамогранитную плиту на подходящий рабочий стол или на ровную поверхность из нескользкого материала.

• Прямая резка: Для резки плит Caesar формата 160x320 см, 120x278 см, можно использовать плиткорез с направляющей, режущей кареткой и присосками, кусачки и алмазную губку. Рекомендуется положить направляющую плиткореза на плиту, отметить концы части плитки, которую предстоит отрезать, затем начертить на плите линию надреза, при этом крайне

необходимо хорошо закрепить направляющую соответствующими присосками. Сначала следует нанести риски длиной около 5 см на обоих концах плиты, действуя от середины к краям, после чего сделать надрез по всей длине начерченной линии, соединив риски. Затем необходимо разломить плиту кусачками по линии надреза, начиная с концов. Наконец, рекомендуется отшлифовать срез алмазной губкой. При необходимости выполнения линейной резки рядом с кромкой можно использовать должным образом прикрепленную к направляющей шлифмашинку.

• Резка под углом 45°: также и резку под углом 45° можно выполнять как резку рядом с кромкой, для чего шлифмашинку следует установить под необходимым углом.

• Г-образная резка: для ее выполнения рекомендуется использовать шлифовальную машинку с алмазным диском и алмазной коронкой для влажного сверления. Перед началом резки просверлите отверстия диаметром 7-8 мм по углам вырезаемой формы. Затем шлифовальной машинкой выполните два надреза длиной около 5 см на концах данного участка и соедините отверстие с надрезами, двигаясь от середины к краю.

• Прямоугольные отверстия: они, как и Г-образная резка, выполняются с помощью шлифовальной машинки с алмазным диском и алмазной коронкой

для влажного сверления. Перед резкой следует сначала просверлить отверстия диаметром 7-8 мм по углам вырезаемой формы. Затем следует соединить отверстия, прорезав плиту угловой шлифовальной машинкой с алмазным диском.

• Отверстия: Отверстия в этом материале можно вырезать алмазной коронкой для влажного сверления, закрепленной на шурупверте. Во время сверления необходимо смачивать поверхность водой. Просверлив отверстие, следует отшлифовать поверхность угловой шлифовальной машинкой с алмазным диском.

Перечень средств, необходимых для перемещения, резки и сверления:

- рама с присосками для подъема и перемещения плит, при необходимости – тележка на колесах;
- рабочий стол, подходящий для соответствующих форматов;
- плиткорез с направляющей и режущей кареткой;
- кусачки;
- алмазная губка;
- шлифовальная машинка с алмазным диском;
- алмазная коронка для влажного сверления;
- шурупверт.

Consigli di posa su massetto

(per rivestimenti di tutte le lastre e pavimenti delle lastre 9 mm)

Recommendations for installation on a screed for wall tiling (all types of slab) and floor tiling (9 mm thick slab)

Conseils de pose sur chape

(pour le revêtement des murs avec tous les types de dalles et pour le revêtement des sols avec des dalles d'une épaisseur de 9 mm)

Empfehlungen für die Verlegung auf Estrich

(an der Wand für alle Platten und am Boden für die 9 mm starken Platten)

Рекомендации по укладке на стяжку

(для облицовки стен любой плитой и для настила полов плитой толщиной 9 мм).

Come riferimento normativo si consiglia di consultare la norma UNI 11493 che regolamenta la posa di pavimenti e rivestimenti interni ed esterni.

As reference, we recommend you to consult the UNI 11493 standard that sets forth the rules for installation of interior and exterior floor and wall coverings.

À ce propos, il est conseillé de consulter la norme UNI 11493 qui régit la pose de carrelages et de revêtements intérieurs et extérieurs.

Zur Normenlage empfiehlt sich die Einsicht in die Richtlinie UNI 11493 zur Verlegung von Wand- und Bodenbelägen in Innen- und Außenbereichen.

В качестве справочно-нормативной документации мы советуем обратиться к стандарту UNI 11493, предписывающему правила по укладке напольной и облицовочной плитки в помещениях и на улице.

Prima di procedere con la posa è necessario verificare che il fondo di posa sia stato progettato e realizzato in modo conforme a quella che è la destinazione d'uso, e correttamente predisposto all'incollaggio della lastra ceramica. Nel caso di massetto cementizio, per la posa a pavimento o a rivestimento è necessario che il fondo di posa non presenti fessurazioni, sia perfettamente asciutto e che il ritiro igrometrico di maturazione sia terminato. È anche necessario verificare che non vi sia assorbimento di umidità o acqua tali da rigonfiare la superficie di supporto. Pulire la superficie rimuovendo polvere, sporco in genere, oli e grassi. Prima di procedere con la posa è necessario verificare la planarità della superficie colmando eventuali dislivelli con adeguati prodotti per la rasatura. Si consiglia l'utilizzo di collanti di categoria "C2 E" o superiore, secondo le normative EN 12004; per la posa a rivestimento è opportuno utilizzare prodotti a scivolamento verticale limitato (indicati con la lettera T, sempre in base alla norma EN 12004). L'adesivo dovrà essere applicato secondo il metodo della doppia spalmatura, al fine di assicurare la perfetta distribuzione dello stesso e di garantire l'adesione ottimale evitando la formazione di vuoti che potrebbero essere causa di rotture. Il collante dovrà essere steso a letto pieno sulla superficie di supporto, utilizzando una spatola con denti distanziati di 10 mm e avendo cura di orientare l'ultima spatolatura con le righe in un unico verso, parallelo al lato corto della lastra. L'applicazione dell'adesivo sul retro della lastra deve essere effettuato mediante una spatola con denti da 3 mm, con la lastra fissata in posizione verticale al telaio di movimentazione. Con l'aiuto del telaio si potrà poi procedere al corretto posizionamento della lastra e alla sua posa. Per favorire il deflusso d'aria e quindi una migliore adesione, si consiglia di far eseguire alla lastra un movimento circolare nel momento della posa. Dopo la posa, si raccomanda di procedere alla battitura della superficie con apposito battitore, procedendo dal centro verso i lati, parallelamente al lato corto, per assicurare il corretto deflusso dell'aria. Si consiglia di valutare l'impiego di sistemi di livellamento delle superfici, per migliorare la planarità. Caesar, al fine di garantire una migliore resa estetica del prodotto ed una maggiore funzionalità, consiglia una fuga di almeno 2 mm e raccomanda l'utilizzo delle specifiche crocette distanziatrici. Inoltre, la granulometria del materiale fugante deve essere adeguata alla larghezza della fuga realizzata, e le fughe devono essere riempite fino al piano di calpestio, creando così una superficie continua. È necessario posizionare i giunti di dilatazione con regolarità e lasciare una distanza di almeno 5 mm fra piastrellato e muri perimetrali (o i pilastri). In ogni

caso, la disposizione dei giunti di dilatazione deve essere calcolata dal responsabile o direttore dei lavori. Tutte le note sopra menzionate non possono in ogni caso prescindere da una posa eseguita a "regola d'arte".

Before beginning installation, check that the substrate for installation has been prepared and built in compliance with the intended use and has been correctly prepared for the use of adhesive. If the case of cement-based screeds, for floor and wall installation, check that the substrate features no cracks, that it is perfectly dry and that hygrometric shrinkage has ended. Make sure that there is no damp or water seepage that could cause the slabs to dislodge. Clean the surface to remove dust, dirt, oil and grease. Before installation, check the flatness of the substrate and compensate for any hollows with suitable levelling products. Use category "C2 E" or superior adhesives, as envisaged by the EN 12004 standards; for wall tiling, use products with limited vertical slippage (identified by the letter T or in compliance with the EN 12004 standard). Adhesive must be applied with the double spreading technique, in order to ensure correct distribution of the adhesive itself, guarantee excellent adhesion and avoid air gaps that can lead to breakage. The adhesive must be spread full-bed on the supporting surface, using a notched trowel (10 mm gap between notches). Make sure that the stripes of the last layer of adhesive have a single direction, parallel to the short side of the slab. The application of adhesive on the rear side of the slab must be performed using a notch with 3 mm notches. The slab must be secured in upright position to the handling frame. Using the frame, you can thus correctly position the slab and install it accordingly. To eliminate any air and guarantee better adhesion, when installing make the slab performs a circular movement. After installation, it is recommended to tap the surface with a special mallet. Proceed from the centre to the sides, parallel to the short side, to ensure effective elimination of air. Consider the use of levelling systems to improve flatness of the surfaces. In order to improve aesthetic performance and practicality, Caesar recommends a grouting joint of at least 2 mm and use of spacer crosses. The grain size of the jointing material must be suitable for the width of the joint. Joints must be filled up to treading level in order to create a continuous surface. Position expansion joints at a regular distance and leave a gap of at least 5 mm between tiled surface and walls (or pillars). In any case, provision of expansion joints must be calculated by the person in charge of the building site. All notes above are a necessary addition to the rules of the trade.

Avant de poser les dalles, vérifier que le fond a été conçu et réalisé conformément à la destination prévue et correctement préparé pour l'encollage de la dalle en céramique. En présence de fondation en béton, pour la pose au sol ou le revêtement de parois, le support de pose doit être parfaitement sec et sans fissures, et le retrait hygrométrique de séchage complété. Il est nécessaire de s'assurer de l'absence de toute absorption d'humidité ou d'eau risquant de faire gonfler la surface de support. Nettoyer la surface en éliminant la poussière, toute saleté, les huiles et les graisses. Avant d'effectuer la pose, il est nécessaire de s'assurer de la planéité de la surface en comblant toute irrégularité à l'aide de produits de ragréage. Il est conseillé d'utiliser un mortier-colle de catégorie « C2 E » ou supérieure, conformément aux normes EN 12004 ; il peut être nécessaire, pour le revêtement de parois, d'utiliser des produits à glissement vertical limité (indiqués par la lettre T, toujours conformément à la norme EN 12004). Appliquer le mortier-colle selon la méthode du double encollage afin d'en assurer la répartition parfaite et d'optimiser l'adhérence en évitant la formation de vides qui pourraient provoquer des ruptures. Étaler le mortier-colle sur toute la surface de support à l'aide d'une spatule à dents espacées de 10 mm, en ayant soin d'orienter la spatule, lors du dernier passage, de manière à ce que les rayures aillent dans le même sens, parallèle au côté court de la dalle. L'application du mortier-colle au dos de la dalle requiert l'utilisation d'une spatule à dents de 3 mm. La dalle doit être fixée au châssis de manutention à la verticale. Ce châssis permettra ensuite de positionner correctement la dalle et de la poser. Pour favoriser l'évacuation de l'air et donc améliorer l'adhésion, il est conseillé d'imprimer un mouvement circulaire à la dalle lors de la pose.

Il est recommandé, au terme de la pose, de taper sur la surface à l'aide d'un maillet en partant du milieu pour aller vers les côtés de manière à chasser l'air. Il est conseillé d'envisager des systèmes de nivellement des surfaces afin d'améliorer la planéité. Caesar conseille, afin d'optimiser le rendu esthétique du produit et sa fonctionnalité, de réaliser un joint d'au moins 2 mm à l'aide de croisillons d'écartement. De plus, la granulométrie du matériau de jointoiment doit être appropriée à la largeur du joint réalisé et les joints doivent être entièrement remplis afin de créer une surface continue. Il faut placer les joints de dilatation à intervalles réguliers et ménager une distance d'au moins 5 mm entre la surface carrelée et les murs (ou les piliers) situés autour. La disposition des joints de dilatation doit dans tous les cas être calculée par le responsable ou le directeur des travaux. Toutes les

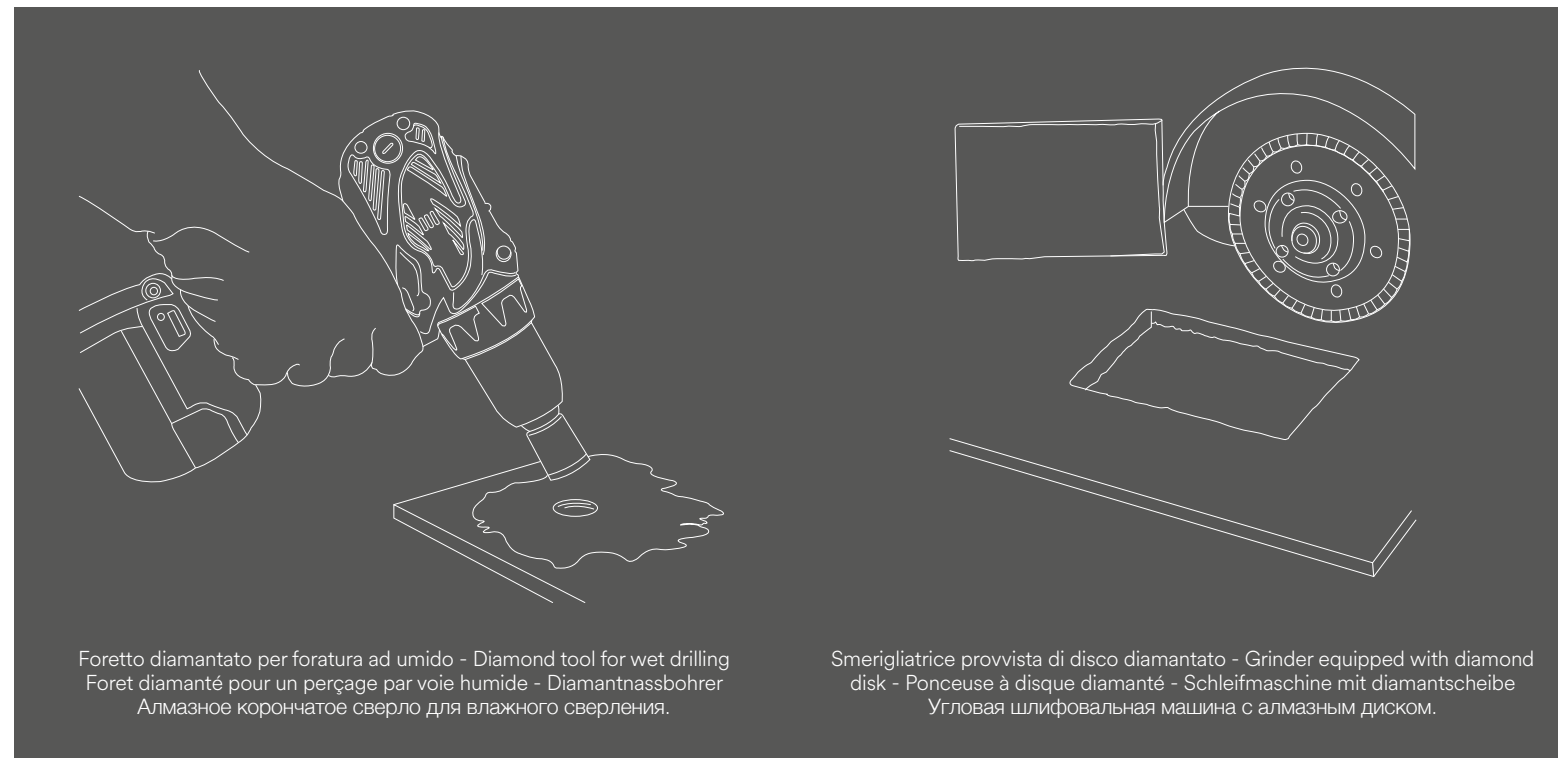

Foretto diamantato per foratura ad umido - Diamond tool for wet drilling
Foret diamanté pour un perçage par voie humide - Diamantnassbohrer
Алмазное корончатое сверло для влажного сверления.

Smerigliatrice provvista di disco diamantato - Grinder equipped with diamond disk - Ponceuse à disque diamanté - Schleifmaschine mit diamantscheibe
Угловая шлифовальная машина с алмазным диском.

instructions susmentionnées doivent être respectées afin que la pose soit exécutée dans les « règles de l'art ».

Vor der Verlegung ist sicherzustellen, dass der Verlegeuntergrund dem Bestimmungszweck konform ausgelegt und ausgeführt wurde und korrekt auf die Verklebung der Keramikplatte vorbereitet wurde. Im Falle eines Zementstrichs muss der Verlegeuntergrund für die Verlegung an Boden oder Wand rissfrei und vollkommen trocken sein, und die trocknungsbedingte Schwindung muss abgeschlossen sein. Es ist sicherzustellen, dass keine Feuchtigkeits- oder Wasseraufnahme vorhanden ist, die den Untergrund aufblähen könnte. Staub und Schmutz im Allgemeinen, Öle und Fette von der Oberfläche beseitigen. Vor der Verlegung muss die Ebenheit der Oberfläche sichergestellt werden: eventuelle Unebenheiten sind mit geeigneten Glättmassen auszugleichen. Wir empfehlen Kleber der Kategorie "C2 E" oder höher nach den Richtlinien EN 12004; bei der Wandverklebung sollten Produkte mit verringertem Abrutschen (nach EN 12004 durch den Buchstaben T gekennzeichnet) verwendet werden. Der Kleber ist doppelt aufzutragen, d.h. auf den Untergrund und auf die Plattenrückseite, um eine perfekte Verteilung und optimales Anhaften zu garantieren, ohne dass Hohlstellen entstehen, die zu Brüchen führen könnten. Den Kleber ganzflächig auf den Untergrund auftragen. 10 mm-Zahnpachtel verwenden und darauf achten, dass beim letzten Auftrag die Rillen in einheitlicher Richtung verlaufen, parallel zur kurzen Seite der Platte. Auf die Plattenrückseite den Kleber mit 3 mm-Zahnpachtel auftragen, während die Platte senkrecht im Transportrahmen fixiert ist. Mit dem Rahmen kann die Platte anschließend korrekt positioniert und verlegt werden. Damit die Luft besser entweichen und die Platte dadurch besser anhaften kann, empfiehlt es sich, diese während der Verlegung mit kreisförmigen Bewegungen zu verschieben. Nach der Verlegung sollte die Platte mit einem Gummihammer leicht angeklopft werden. Hierzu von der Mitte ausgehend nach außen vorgehen, parallel zur kurzen Seite, damit eingeschlossene Luft

entweichen kann. Es empfiehlt sich, Nivelliersysteme anzuwenden, um die Ebenheit der Flächen zu verbessern. Zur Erzielung einer optimalen optischen Wirkung und Funktionalität des Produkts empfiehlt Caesar eine Fugenbreite von mindestens 2 mm sowie die Verwendung von Fugenkreuzen. Die Körnung des Fugenmaterials muss außerdem für die ausgeführte Fugenbreite geeignet sein, und die Fugen sind mit der Trittläche bündig zu füllen, so dass eine kontinuierliche Fläche entsteht. In regelmäßigen Abständen sind Dehnungsfugen anzubringen, und zwischen Umfangsmauern (bzw. Pfeilern) und Fliesenbelag sind wenigstens 5 mm Abstand zu lassen. In jedem Fall ist die Anordnung der Dehnungsfugen durch den Bauleiter zu berechnen.

Neben den obigen Hinweisen sind in jedem Fall die Regeln einer fachgerechten Fliesenverlegung unbedingt zu beachten.

Перед укладкой необходимо проверить, что основа спроектирована и выполнена с учетом будущих условий эксплуатации покрытия и подготовлена надлежащим образом к наклеиванию плитки. В случае цементной стяжки как при напольной, так и при настенной укладке убедиться, что на основе нет трещин, что она совершенно сухая, и что процесс ее усадки при созревании завершен. Также следует убедиться в отсутствии поглощения воды или влаги, способного привести к вспучиванию поверхности основы. Очистите подлежащую облицовке поверхность от пыли, масел, жиров и грязи вообще. Перед началом укладки необходимо проверить, чтобы основа была ровной, и в случае необходимости выровнять ее подходящим составом. Мы советуем использовать клеи класса "C2 E" или более высокого класса по стандарту EN 12004; для настенной укладки следует выбирать клеи с уменьшенной степенью вертикального сползания (обозначаются буквой Т по стандарту EN 12004). При укладке рекомендуется применять метод двойного нанесения клея; это гарантирует оптимальное распределение и сцепление клея, а

также отсутствие пустот, которые могут привести к расколу уложенных плит. Клей наносят сплошным слоем на подлежащую облицовке поверхность при помощи зубчатого шпателя с расстоянием между зубьями в 10 мм, борозды последней полосы клея должны быть ориентированы в одном направлении, параллельно короткой грани плитки. Для нанесения клея на монтажную сторону плитки следует использовать шпатель с размером зубьев в 3 мм, плитка при этом должна быть закреплена в вертикальном положении на раме, используемой для перемещения. С помощью этой рамы затем можно будет уложить плитку в правильном положении. Чтобы удалить воздушные пузырьки из клеевой прослойки и улучшить сцепление, в момент укладки рекомендуется произвести плитой круговое движение. После укладки для удаления воздуха рекомендуется равномерно простучать поверхность плитки подходящим инструментом от середины к краям, параллельно короткой стороне. Для обеспечения ровности покрытия советуем использовать специальные системы выравнивания. Для лучшего эстетического результата, а также из практических соображений, компания Caesar рекомендует укладку со швом не менее 2 мм с использованием дистанционных крестиков. Фракция затирочного материала подбирается с учетом рекомендованного размера шва. Швы заполняются затиркой до краев так, чтобы они образовывали единую плоскость с поверхностью плит. Необходимо равномерно установить деформационные швы, оставляя между полом и стенами (или колоннами) зазор размером не менее 5 мм. Расстановка деформационных швов рассчитывается руководителем укладочных работ. Укладка плит в любом случае должна производиться с соблюдением не только настоящих инструкций, но и всех правил по выполнению укладочных работ. Укладка плит в любом случае должна производиться с соблюдением не только настоящих инструкций, но и всех правил по выполнению укладочных работ.

Posa a pavimento delle lastre 6 mm

Installation of 6 mm thick slabs - Pose des dalles 6 mm au sol

Verlegung der 6 mm starken Platten am Boden - Напольная укладка плит толщиной 6 мм

Caesar raccomanda l'utilizzo a pavimento delle grandi lastre in spessore 6mm per le sole applicazioni in ambito residenziale, commerciale a traffico leggero e comunque in contesti ove non vi sia passaggio di carichi puntuali pesanti o transito di carrelli a ruote dure. La gamma di grandi lastre in 6 mm di spessore è indicata per la posa su pavimenti preesistenti: è possibile effettuare la posa su vecchi pavimenti o rivestimenti in marmo, pietra naturale, ceramica, senza la necessità di demolire la pavimentazione sottostante. ATTENZIONE: è sconsigliata la posa di queste lastre direttamente sul massetto. Questo perché la posa su massetto è fortemente condizionata dall'esecuzione ottimale del massetto stesso, dalla sua completa stagionatura, dal rispetto degli opportuni giunti di dilatazione nonché dalla posa effettuata a "regola d'arte". Pertanto, in questi casi, Caesar suggerisce l'utilizzo di grès porcellanato in spessore tradizionale.

Caesar recommends the installation of 6 mm thick extra large slabs only in the following conditions: residential environments, commercial environments that are subject to light traffic and in any case in contexts where there is no regular passage of heavy loads or circulation of trolleys with hard wheels. The range of 6 mm thick extra large slabs is suitable for installation on existing floors: the slabs can be installed on old floors or marble, natural stone and ceramic claddings, without the need to demolish the existing underlying floor.

ATTENTION: it is not recommended to install these slabs on a screed directly. since the results of installation strictly relate to the condition - excellent - of the screed, to its seasoning, to the

provision of expansion joints, as well as to perfect installation in accordance to "the rules of the trade". In these cases, Caesar recommends the use of porcelain stoneware with a conventional thickness.

Pour le revêtement des sols, Caesar conseille l'utilisation des grandes dalles d'une épaisseur de 6 mm uniquement pour le secteur résidentiel, les zones commerciales à trafic léger et, quoi qu'il en soit, dans des contextes ne prévoyant pas le passage de charges lourdes ponctuelles ou de chariots à roues dures. La gamme de grandes dalles d'une épaisseur de 6 mm est indiquée pour la pose sur des sols préexistants : il est possible d'effectuer la pose sur de vieux sols ou des revêtements en marbre, pierre naturelle, céramique sans devoir pour autant démolir le sol sous-jacent.

ATTENTION : il est déconseillé de poser ces dalles directement sur la chape. En effet une pose sur chape exécutée dans les « règles de l'art » dépend beaucoup de l'exécution optimale de la chape elle-même, de son séchage complet et du respect du positionnement des joints de dilatation. Dans ces cas, Caesar suggère l'utilisation d'un grès cérame à épaisseur traditionnelle.

Caesar empfiehlt die Verwendung der großen Platten in 6 mm Stärke als Bodenbelag nur für den Wohnungsbau, für nur leicht beanspruchte Gewerbeobjekte und in jedem Fall nur in Bereichen, in denen keine konzentrierten, schweren Lasten vorhanden sind bzw. die nicht von Transportwagen mit Hartgummirädern befahren werden. Die Palette der 6 mm starken, großen Platten eignet sich für die Verlegung über bereits vorhandenen Bodenbelägen: Eine Überverlegung auf bestehenden Bodenbelägen

TECHNICAL DETAILS

aus Marmor, Naturstein, Keramik ist möglich, ohne den vorhandenen Belag demolieren zu müssen. ZUR BEACHTUNG: Von der Verlegung dieser Platten direkt auf den Estrich wird abgeraten. Grund hierfür ist, dass die Verlegung auf Estrich in hohem Maße von der perfekten Ausführung des Estrichs selbst abhängt, von seiner vollständigen Aushärtung, von der korrekten Ausführung der Dehnungsfugen sowie von der „fachgerechten Verlegung“ im Allgemeinen. In diesen Fällen empfiehlt Caesar daher die Verwendung von Feinsteinzeug in traditioneller Stärke.

Caesar рекомендует напольную укладку крупноформатных плит толщиной 6 мм исключительно в жилых и коммерческих объектах с небольшой интенсивностью хождения и в любом случае там, где не предусматривается движение тяжелых сосредоточенных нагрузок или перевозка тележек с жесткими колесами. Ассортимент крупноформатных плит толщиной 6 мм подходит для укладки поверх уже существующих полов. Возможна укладка на старый пол или облицовку из мрамора, натурального камня, керамики, без необходимости разбора уже существующих покрытий. ВНИМАНИЕ: не рекомендуется укладка этих плит непосредственно на стяжку. Это вызвано тем, что на укладку на стяжку сильно влияют качественное изготовление стяжки, ее полная выдержка, присутствие всех необходимых расширительных швов, а также безупречное выполнение самой укладки. Поэтому, для такой укладки Caesar рекомендует использовать керамогранит обычной толщины.

Manutenzione e pulizia

Care and cleaning - Entretien et nettoyage

Pflege und Reinigung - Чистка и уход

Al fine di facilitare la manutenzione ordinaria si raccomanda di effettuare un lavaggio acido dalle 36 alle 48 ore dalla stuccatura con un acido specifico per grès porcellanato. Per ulteriori informazioni si rimanda a quanto riportato nella più recente edizione del Catalogo generale Caesar ed al sito www.caesar.it.

In order to make routine maintenance easier, it is recommend to wash the surface with an acid detergent 36-48 hours from grouting. Use an acid product that is suitable for porcelain stoneware. For more information, refer to the latest edition of the

Caesar General Catalogue and visit the www.caesar.it website.

Il est recommandé, afin de faciliter l'entretien de routine, d'effectuer un lavage acide 36 à 48 heures après le jointoiement avec un acide spécifique pour grès cérame. Pour de plus amples informations, consulter la dernière édition du catalogue général Caesar et le site www.caesar.it.

Zur Erleichterung der ordentlichen Wartung sollten die Platten 36 bis 48 Stunden nach dem Verfugen

mit einer spezifischen Säure für Feinsteinzeug abgewaschen werden. Weitere Informationen finden Sie in der neuesten Ausgabe des Caesar-Gesamtkatalogs und in der Website www.caesar.it.

Чтобы упростить уход за плиткой, спустя 36-48 часов после затирки швов рекомендуется промыть облицованную поверхность кислотным моющим средством для керамогранита. Дополнительная информация доступна в последнем издании Общего каталога Caesar и на сайте www.caesar.it.

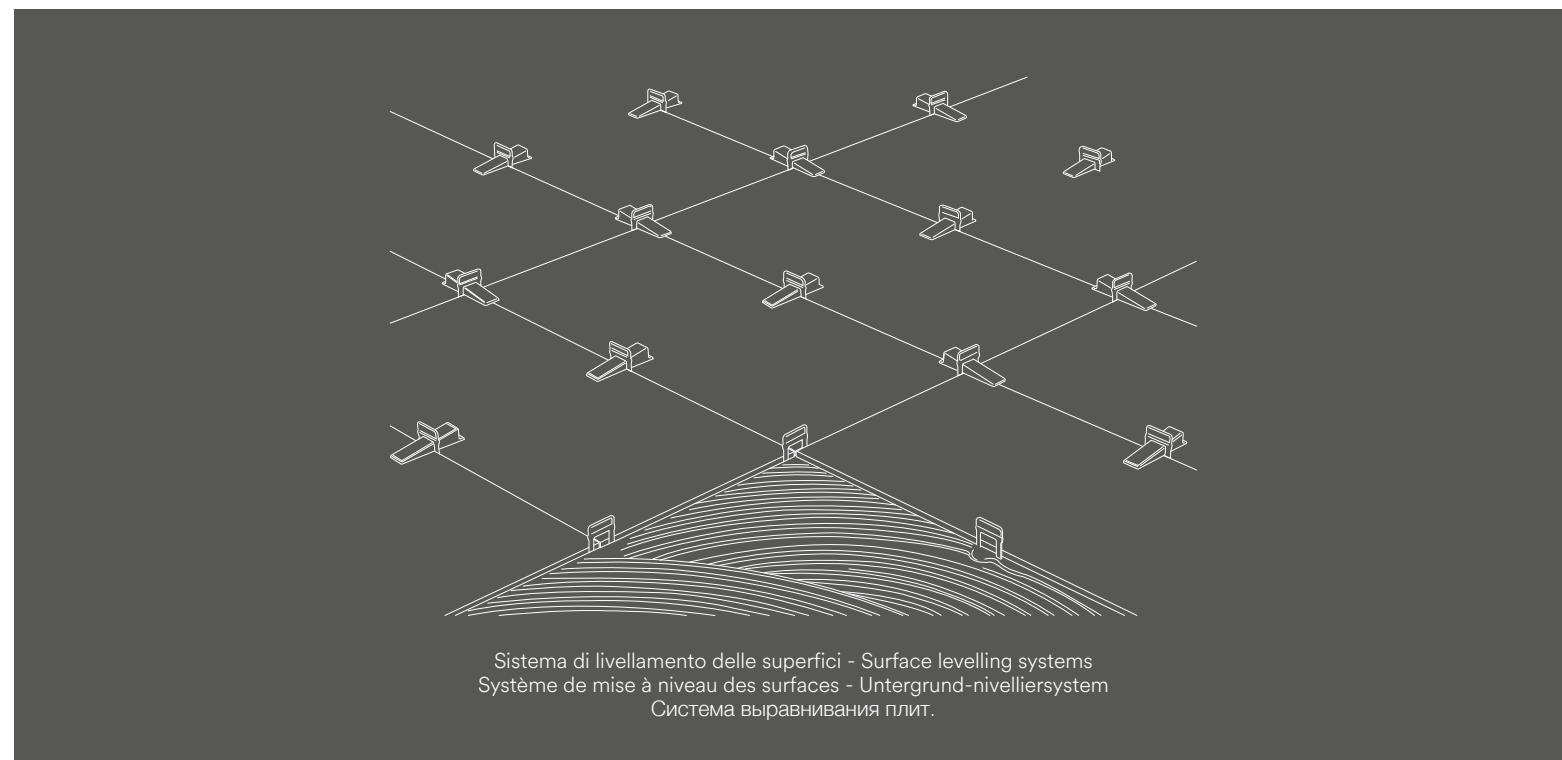

Stuoatura delle lastre

Slab mesh covering - Entoilage des dalles

Platten mit Gfk-Matte - Установка мата на плиты

Le lastre Caesar possono essere fornite su richiesta, su tutti i formati e gli spessori in gamma, con l'integrazione di una stuoia in fibra di vetro, che viene applicata sul retro. Questa lavorazione è particolarmente indicata per elementi di arredo laddove le lastre non siano incollate a supporti interni, o comunque siano particolarmente sollecitate. Le lastre accoppiate alla stuoia acquisiscono una maggiore resistenza all'urto nella fase di trasporto. Inoltre la procedura aumenta la sicurezza in caso di rotture, dal momento che la stuoia impedisce il collassamento della lastra.

Upon demand, Caesar slabs can be supplied with fibreglass mesh applied to the bottom face. This type of product is recommended when slabs used as furniture covering will not be glued to supports and when particular stress is expected. Slabs on mesh acquire a greater resistance to impact. Furthermore, the application of fibreglass increases safety in the event of breakage since mesh withholds fragments. The designer must

check if the slabs needs a support, based on its specific application.

À la demande, les dalles Caesar peuvent être livrées avec une couche en fibre de verre appliquée à l'arrière. Ce traitement est particulièrement indiqué pour les éléments décoratifs lorsque les dalles ne sont pas collées à des support internes ou qu'elles subissent des contraintes particulières. Ainsi consolidées par la fibre de verre, les dalles offrent une meilleure résistance mécanique et aux chocs. De plus, l'application de la fibre renforce la sécurité en cas de rupture en retenant les fragments. Il appartient au concepteur de vérifier si la dalle, en fonction de sa destination spécifique, doit reposer sur un support.

Die Platten von Caesar sind auf Wunsch mit rückseitig aufgebracht Glasfasermatte lieferbar. Diese Ausführung eignet sich insbesondere für Einrichtungselemente, bei denen die Platten nicht auf einer Unterlage verklebt werden, bzw. generell bei besonders hoher Beanspruchung. Die mit dieser Matte versehenen Platten besitzen eine höhere

mechanische Beständigkeit und Stoßfestigkeit. Zudem bietet die Glasfasermatte bei einem Brechen größere Sicherheit, da sie die Fragmente zurückhält. Die Prüfung der Notwendigkeit der Matte für den jeweiligen Verwendungszweck der Platte ist Aufgabe des Planers.

По заказу плиты Caesar могут оснащаться дополнительным матом из стекловолокна, устанавливаемым с тыльной стороны. Рекомендуется выполнить обработку при изготовлении предметов интерьера, если плиты не приклеиваются к внутренним опорным конструкциям, или если к ним прилагается высокая нагрузка. Совмещенные с матом плиты приобретают более высокую прочность к механическому воздействию и ударам. Кроме того, наклеивание мата повышает безопасность в случае разбивания, потому что не допустит разбрасывания осколков. В зависимости от конкретного применения проектировщик обязан проверять необходимость опорного материала для плиты.



È compito del progettista verificare se la lastra necessita di un supporto, in funzione dell'applicazione specifica.

The designer must check if the slabs needs a support, based on its specific application.

Il appartient au concepteur de vérifier si la dalle, en fonction de sa destination spécifique, doit reposer sur un support.

Für die Prüfung der vom Verwendungszweck abhängigen Notwendigkeit einer Unterlage ist der Planer zuständig.

В зависимости от конкретного применения проектировщик обязан проверять необходимость опорного материала для плиты.

Sistemi di imballaggio delle lastre

Slab packaging methods - Systèmes d'emballage des dalles

Verpackungssysteme für die Platten - Системы упаковки плит

Cassa

Crate
Caisse
Kiste
Ящик

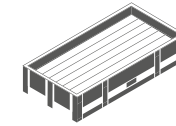

| FORMATO CM SIZE CM FORMAT CM FORMAT CM ФОРМАТ, CM | SPESSORE THICKNESS ÉPAISSEUR STÄRKE ТОЛЩИНА | DIMENSIONE IMBALLO DIMENSIONS OF PACKAGE DIMENSIONS DE L'EMBALLAGE VERPACKUNGSABMESSUNGEN РАЗМЕР УПАКОВКИ | LASTRE SLABS DALLES PLATTEN ПЛИТЫ | M² PZ | M² TOT | KG/PZ | KG | TARA KG TARE KG TARE KG TARA KG ТАРА KG | PESO TOT KG TOT. WEIGHT KG POIDS TOT. KG GESAMTGEWICHT KG ОБЩАЯ МАССА KG |
|---------------------------------------------------------------|---------------------------------------------------------|-----------------------------------------------------------------------------------------------------------------------|-----------------------------------------------|--------|--------|--------|---------|-----------------------------------------------------|--------------------------------------------------------------------------------------|
| 160x320 | 6 mm / 0,23" | (344,2x174,5x(h)37,4 cm) | 14 | 5,12 | 71,68 | -78 | -1092 | -140 | -1232 |
| 160x320 | 12 mm / 0,23" | (344,2x174,5x(h)37,4 cm) | 8 | 5,12 | 40,96 | -148 | -1184 | -140 | -1324 |
| 120x278 | 6 mm / 0,23" | (144,6x291,6x(h)33,8 cm) | 18 | 3,3221 | 59,79 | -49,56 | -892,08 | -88 | -980,08 |
| 120x278 | 6 mm / 0,23" | (144,6x291,6x(h)23,8 cm) | 5 | 3,32 | 16,61 | -49,56 | -247,8 | -52,5 | -300,3 |

Cavalletto

Trestle
Chevalet
Bock
Подставка

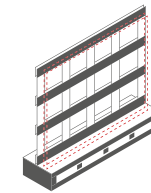

| FORMATO CM SIZE CM FORMAT CM FORMAT CM ФОРМАТ, CM | SPESSORE THICKNESS ÉPAISSEUR STÄRKE ТОЛЩИНА | DIMENSIONE IMBALLO DIMENSIONS OF PACKAGE DIMENSIONS DE L'EMBALLAGE VERPACKUNGSABMESSUNGEN РАЗМЕР УПАКОВКИ | LASTRE SLABS DALLES PLATTEN ПЛИТЫ | M² PZ | M² TOT | KG/PZ | KG | TARA KG TARE KG TARE KG TARA KG ТАРА KG | PESO TOT KG TOT. WEIGHT KG POIDS TOT. KG GESAMTGEWICHT KG ОБЩАЯ МАССА KG |
|---------------------------------------------------------------|---------------------------------------------------------|-----------------------------------------------------------------------------------------------------------------------|-----------------------------------------------|--------|---------|--------|---------|-----------------------------------------------------|--------------------------------------------------------------------------------------|
| 160x320 | 6 mm / 0,23" | (330x75x(h)195,3 cm) | 14 | 5,12 | 71,68 | -78 | -1092 | 210 | -1302 |
| 160x320 | 12 mm / 0,23" | (330x75x(h)195,3 cm) | 8 | 5,12 | 40,96 | -148 | -1184 | 210 | -1394 |
| 120x278 | 6 mm / 0,23" | (290x75x(h)156 cm) | 18 | 3,3221 | 59,7978 | -49,56 | -892,08 | 185 | -1077,08 |

Cavalletto max load

Max. Load of trestle
Chevalet max
Maximal beladener bock
Подставка с максимальной
нагрузкой

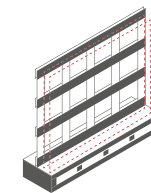

| FORMATO CM SIZE CM FORMAT CM FORMAT CM ФОРМАТ, CM | SPESSORE THICKNESS ÉPAISSEUR STÄRKE ТОЛЩИНА | DIMENSIONE IMBALLO DIMENSIONS OF PACKAGE DIMENSIONS DE L'EMBALLAGE VERPACKUNGSABMESSUNGEN РАЗМЕР УПАКОВКИ | LASTRE SLABS DALLES PLATTEN ПЛИТЫ | M² PZ | M² TOT | KG/PZ | KG | TARA KG TARE KG TARE KG TARA KG ТАРА KG | PESO TOT KG TOT. WEIGHT KG POIDS TOT. KG GESAMTGEWICHT KG ОБЩАЯ МАССА KG |
|---------------------------------------------------------------|---------------------------------------------------------|-----------------------------------------------------------------------------------------------------------------------|-----------------------------------------------|--------|----------|--------|-----------|-----------------------------------------------------|--------------------------------------------------------------------------------------|
| 160x320 | 6 mm / 0,23" | (330x75x(h)195,3 cm) | 42 | 5,12 | 215,4 | -78 | -3.276 | 210 | -3.486 |
| 160x320 | 12 mm / 0,23" | (330x75x(h)195,3 cm) | 22 | 5,12 | 112,64 | -148 | -3.256 | 210 | -3.466 |
| 120x278 | 6 mm / 0,23" | (290x75x(h)156 cm) | 36 | 3,3221 | 119,5956 | -49,56 | -1.784,16 | 185 | -1.969,16 |

Caesar raccomanda di non sovrapporre pallet di altro tipo alle casse contenenti questi prodotti.

Caesar recommends you not to stack other types of pallet onto the crates containing these products.

Caesar recommande de ne pas superposer d'autres types de palettes sur les caisses contenant ces produits.

Caesar empfiehlt, keine anderen Palettentypen auf die Kisten mit diesen Produkten zu legen.

Caesar рекомендует не ставить поддоны другого типа на ящики, содержащие данные плиты.

Pulizia e precauzioni per l'uso

Cleaning and precautions for use - Nettoyage et précautions d'emploi

Entwurf Reinigung Vorsichtsmassnahmen bei der Benutzung - Чистке и меры предосторожности при использовании

PULIZIA

La manutenzione ordinaria dovrà essere effettuata con prodotti detergenti specifici per rimuovere sporco e macchie purché non siano ceranti, filmanti o pellicolanti. Consideriamo il risciacquo con acqua pulita fondamentale per un'ottima operazione di pulizia, per cui sconsigliamo l'utilizzo di prodotti con l'indicazione "non occorre il risciacquo". Prodotti molto chiari, oppure di colore nero intenso, soprattutto nella finitura Lucidata, pur essendo sempre pulibili dal punto di vista igienico, sono relativamente delicati rispetto a taluni tipi di macchia, poiché a volte le stesse possono lasciare tracce o aloni più visibili rispetto a prodotti con tinte intermedie: la pulizia dovrà essere tempestiva e accurata.

Macchie particolari di sporco necessitano di una pulizia straordinaria con detergenti specifici per il tipo di macchia. A seconda del tipo di macchia possiamo intervenire con un prodotto:

- ACIDO per macchie di natura INORGANICA (per esempio cemento, calcare, ruggine, stucchi cementizi o colorati, tempere murali).
- BASICO per macchie di natura ORGANICA (Coca Cola, gelato, caffè, vino, birra, grassi animali e vegetali, mostarda, maionese, ketchup, marmellata, rossetto, cera).
- SOLVENTE per macchie di natura SINTETICA (Olii siliconati e meccanici, resine, smalti).

Per la finitura Lucidata, si sconsiglia l'utilizzo di attrezzature abrasive: in caso di macchie da rimuovere con detergenti acidi, è indispensabile diluire il detergente in acqua, dimezzando la concentrazione acida consigliata dal produttore. E' inoltre fondamentale ridurre la fase di contatto tra lastre ed acido, prevedendo immediatamente dopo la pulizia un abbondante risciacquo con acqua. Si sconsiglia vivamente l'utilizzo di acidi da ferramenta o da scaffale (tipo acido muriatico) perché, oltre ad eliminare i residui di stucco, potrebbero danneggiare irrimediabilmente la superficie delle piastrelle. Si consiglia inoltre di fare attenzione a tutti i prodotti che contengono acido fluoridrico (HF) perché danneggia in modo irreparabile tutte le superfici ceramiche. Nel caso di installazioni che prevedano la stuccatura delle fughe, OLOS raccomanda di eseguire una pulizia finale dopo la posa in opera, con una soluzione acida ad azione tamponata: per i dettagli si rimanda al catalogo generale di Ceramiche Caesar o al sito www.caesar.it.

PRECAUZIONI PER L'USO

Caesar raccomanda il rispetto delle seguenti indicazioni, al fine di evitare l'insorgere di problematiche o danni accidentali:

- prevenire urti accidentali sugli spigoli, i bordi e le superfici delle lastre;
- non sottoporre le superfici a carichi puntuali particolarmente pesanti, soprattutto nelle parti a sbalzo. In particolare si raccomanda di non salire a piedi sui piani per nessun motivo.
- evitare l'utilizzo di coltelli in ceramica a diretto contatto con i piani. Per i piani realizzati con lastre in superficie

Lucidata si sconsiglia anche l'utilizzo dei coltelli in acciaio. In ogni caso di utilizzo di coltelli, è opportuno proteggere la superficie del piano con un tagliere;

- evitare il contatto diretto con superfici molto calde, quali pentole, padelle o caffettiere, utilizzando sottopentole;
- ridurre al minimo i tempi di contatto delle superfici dei piani con prodotti di pulizia ad alta concentrazione, sia acidi che basici: questa raccomandazione riguarda tutte le finiture, specialmente quella Lucidata.
- non utilizzare detergenti abrasivi per pulire i piani;

Caesar non si riterrà in alcun modo responsabile per danni o difettologie imputabili al mancato rispetto delle indicazioni sopra riportate.

CLEANING

Routine cleaning must be performed using specific detergents for removing dirt and stains, upon condition that they do not contain wax and do not form films. Rinsing with clean water is essential for effective cleaning. Therefore, we do not recommended the use of products that do not call for rinsing. Very light or intense black colours, especially those with a Lucidata finish, are easy to sanitise but are relatively delicate when it comes to certain types of stain. The latter can leave traces and marks that are more visible if compared to products with intermediate shades: cleaning must be performed in a timely and accurate manner. Particular types of stain need extra-duty cleaning with specific detergents. Depending on the type of stain, you can use the following products:

- ACID, for INORGANIC stains (e.g. concrete, limescale, rust, cement-based or coloured grout, wall-paint).
- BASES for ORGANIC stains (Coca Cola, ice-cream, coffee, wine, beer, animal and vegetable fats, mustard, mayonnaise, ketchup, jam, lipstick, wax). SOLVENTS for SYNTHETIC stains (silicone-based and mechanical oil, resin, glaze).

As far as the Lucidata finish is concerned, the use of abrasive tools should be avoided: if you need to use an acid detergent to remove your stain, always dilute the product in water and use half of the acid concentration recommended by the manufacturer. It is also essential to reduce slab-acid contact time. Rinse with plenty of water immediately after cleaning.

The use of common aggressive acids (such as muriatic acid for instance) must be avoided. These products do remove residues of grout but they can also irreparably damage the tile's surface. Also pay attention to all products containing hydrofluoric acid (HF) since they irreparably damage all ceramic surfaces. If you are using grout to fill your joints, it is recommended to perform thorough cleaning after installation, using an acid and buffered solution: for further details, see the Ceramiche Caesar general catalogue or www.caesar.it.

PRECAUTIONS FOR USE

In order to prevent issues and accidental damage, Caesar recommends the following:

- prevent accidental collision with slab corners, edges and surfaces;

- do not apply continual and particularly heavy loads on surfaces, especially protruding ones. In particular, do not climb onto or stand on tops for any reason.
- Avoid using ceramic knives on your surfaces. As far as the Lucidata finish is concerned, also avoid using steel knives. In all cases, when using knives, it is recommended to protect your surface with a cutting board;
- avoid direct contact with very hot surfaces, such as pans or coffee pots. Use hot pads;
- minimise contact time of your surfaces with concentrated cleaning agents, both of an acid or basic nature: this recommendation applies to all finishes, especially the Lucidata.
- Never use abrasive detergents to clean your surfaces;

Caesar cannot be held liable for damage or defects resulting from failure to respect the above indications.

NETTOYAGE

Pour l'entretien ordinaire, utiliser des détergents spécifiques pour éliminer la saleté et les taches à condition qu'ils ne laissent ni cire, ni film ni pellicule résiduels. Le rinçage à l'eau claire est essentiel pour un nettoyage efficace ; c'est pourquoi nous déconseillons l'utilisation de détergents portant la mention « sans rinçage ». Les dalles de couleur très claire ou d'un noir intense, notamment en version Lucidata (polie), bien que lavables d'un point de vue hygiénique, sont relativement délicates en ce qui concerne certains types de taches qui peuvent parfois laisser des traces ou des auréoles visibles, contrairement aux produits de teintes intermédiaires : ces dalles doivent être lavées rapidement et soigneusement. Certaines taches particulières nécessitent un nettoyage extraordinaire à l'aide de détergents spéciaux en fonction du type de tache. En fonction du type de tache, il est possible d'intervenir avec les produits suivants :

- ACIDE pour des taches de nature INORGANIQUE (ciment, calcaire, rouille, mortier-colle ou coloré, peintures murales, etc.).
- BASIQUE pour des taches de nature ORGANIQUE (Coca-Cola, glace, café, vin, bière, matières grasses animales et végétales, moutarde, mayonnaise, ketchup, confiture, rouge à lèvres, cire).

SOLVENT pour des taches de nature SYNTHÉTIQUE (huiles au silicone ou mécaniques, résines, vernis).

Pour la finition Lucidata, il est déconseillé d'utiliser tout produit abrasif : en présence de taches à éliminer avec des détergents acides, il est indispensable de diluer le détergent dans l'eau en diminuant de moitié la concentration acide conseillée par le fabricant. Il est également fondamental de réduire la durée du contact entre les dalles et l'acide en rinçant abondamment à l'eau immédiatement après le nettoyage.

Il est fortement déconseillé d'utiliser des acides du commerce (par ex. : acide chlorhydrique) parce qu'en éliminant les résidus de stuc ils risquent de détériorer irrémédiablement la surface des carreaux. Il est de plus conseillé de faire très attention à tous les produits à base d'acide fluorhydrique (HF) car celui-ci abîme irréparablement toutes les surfaces céramiques.

Si la réalisation prévoit le stucage des joints, OLOS

recommende de procéder à un nettoyage final après la pose à l'aide d'une solution acide tamponnée : pour de plus amples détails, veuillez consulter le catalogue général de Ceramiche Caesar ou le site www.caesar.it.

PRÉCAUTIONS D'EMPLOI

Caesar recommande de respecter les indications suivantes afin d'éviter la survenue de problèmes ou de dommages accidentels :

- Prévenir les chocs accidentels sur les angles, les chants et les surfaces des dalles,
 - Ne pas soumettre les surfaces à des charges ponctuelles particulièrement lourdes, notamment sur les parties en saillie. Il est recommandé en particulier de ne jamais monter sur les plateaux.
 - Éviter l'utilisation de couteaux en céramique en contact direct avec les plateaux. Pour les plateaux réalisés avec des dalles à la surface polie, il est également déconseillé d'utiliser des couteaux en acier. En cas d'utilisation de couteaux, protéger la surface du plateau en utilisant une planche à découper.
 - Éviter tout contact direct avec des surfaces très chaudes - casseroles, poêles ou cafetières – en utilisant un dessous de plat.
 - Réduire au minimum la durée du contact des surfaces des plateaux avec des produits d'entretien fortement concentrés : cette recommandation s'applique à toutes les finitions et notamment à la finition polie.
 - Ne pas utiliser de détergents abrasifs pour nettoyer les plateaux.
- Caesar décline toute responsabilité en cas de dégâts ou de défauts découlant du non-respect des recommandations susmentionnées.

ENTWURF REINIGUNG

Für die normale Pflege sind spezielle Reiniger und Fleckenentferner zu verwenden, die kein Wachs enthalten und nicht film- bzw. schichtbildend sind. Das Nachspülen mit sauberem Wasser ist für eine optimale Reinigung unerlässlich, daher raten wir vom Gebrauch von Produkten mit der Angabe: "Ohne Nachspülen" ab. Auch wenn sehr helle oder tiefschwarze Produkte vor allem in der polierten Ausführung „Lucidata“ hinsichtlich der Hygiene einfach zu reinigen sind, erweisen sie sich gegenüber einigen Arten von Flecken als relativ empfindlich. Diese können Spuren oder Ränder hinterlassen, die auf ihnen deutlicher sichtbar sind als auf weniger hellen oder dunklen Produkten: Sie müssen rasch und sorgfältig gereinigt werden. Besondere Flecken erfordern eine spezifische Reinigung mit Spezialreinigern für den jeweiligen Fleckentyp. Je nach Art der Flecken erfolgt dies mit:

- SAUREN REINIGERN bei durch ANORGANISCHE Substanzen bedingten Flecken (beispielsweise Zement, Kalk, Rost, Zementäre oder farbige Fugenmassen, Wandfarben).
- ALKALISCHE REINIGER bei durch ORGANISCHE Substanzen bedingten Flecken (Coca-Cola, Eiskrem, Kaffee, Wein, Bier, tierische und pflanzliche Fette, Senf, Mayonnaise, Ketchup, Marmelade, Lippenstift, Wachs). LÖSEMITTEL bei durch SYNTHETISCHE Substanzen bedingten Flecken (Silikon- und Maschinenöle, Harze, Lacke).

Für die Ausführung „Lucidata“ wird vom Gebrauch scheuernder Werkzeuge abgeraten: Bei durch saure Reiniger zu entfernenden Flecken muss das Reinigungsmittel unbedingt in Wasser verdünnt werden,

wobei die vom Hersteller empfohlene Säuredosierung zu halbieren ist. Die Säure sollte nur so kurz wie möglich auf die Platten einwirken, deshalb ist sie sofort nach der Reinigung mit reichlich Wasser abzuspülen.

Von der Verwendung von Salzsäure wird dringend abgeraten, da diese nicht nur Fugenmassenrückstände beseitigt, sondern auch die Fliesen selbst irreparabel beschädigen könnte. Darüber hinaus sind alle Produkte zu vermeiden, die Flusssäure (HF) enthalten, da diese alle Keramikoberflächen irreparabel beschädigt. Werden die Fliesen verfugt, so empfiehlt OLOS nach der Verlegung eine Abschlussreinigung mit einer gepufferten Säurelösung: Nähere Einzelheiten finden Sie im Gesamtkatalog von Ceramiche Caesar bzw. auf der Website www.caesar.it.

VORSICHTSMASSNAHMEN BEI DER BENUTZUNG

Caesar empfiehlt, folgende Hinweise zu beachten, um Probleme oder Schäden zu vermeiden:

- Stöße gegen die Ecken, Kanten und Oberflächen der Platten vermeiden.
- Konzentrierte, schwere Lasten auf den Platten, vor allem auf eventuell überhängenden Teilen vermeiden. Steigen Sie vor allem niemals auf die Flächen.
- Schneiden Sie nicht mit Keramikmessern direkt auf den Oberflächen. Auf Platten in der Oberflächenversion Lucidata wird auch vom Schneiden mit Stahlmessern abgeraten. In jedem Fall sollte die Fläche beim Schneiden stets mit einem Schneidbrett geschützt werden.
- Vermeiden Sie den direkten Kontakt mit sehr heißen Gegenständen wie Töpfen, Pfannen oder Espresso-Kannen: Stellen Sie diese stets auf Untersetzer.
- Lassen Sie hochkonzentrierte, sowohl saure als auch alkalische Reinigungsmittel nur so kurz wie möglich auf den Flächen einwirken: Diese Empfehlung gilt für alle Oberflächen und ganz besonders für die Version Lucidata.
- Reinigen Sie die Flächen nicht mit scheuernden Reinigungsmitteln.

Caesar haftet nicht für Schäden, die auf die Nichteinhaltung der vorstehenden Hinweise zurückzuführen sind.

ЧИСТКЕ

Плановый уход должен выполняться с применением специальных моющих средств для удаления грязи и пятен, при условии, что они не содержат воск, не образуют пленку или налет. Мы считаем промывку чистой водой чрезвычайно важной для наилучшей чистки, поэтому, не рекомендуем использование продуктов с указанием "не требует смывания". Несмотря на то, что на очень светлых изделиях или же насыщенного черного цвета, в особенности с полированной отделкой, всегда можно проводить гигиеническую чистку, на них очень легко образуются некоторые типы пятен, поскольку иногда на их поверхности могут оставаться более заметные следы или разводы по сравнению с изделиями промежуточных цветов. Чистка должна выполняться своевременно и тщательно. Пятна особенных загрязнений требуют нестандартной чистки с применением специальных моющих средств для данного типа пятна. В зависимости от типа пятна можно использовать следующие продукты:

- КИСЛОТНЫЕ для пятен НЕОРГАНИЧЕСКОГО типа (например, цемент, известь, ржавчина, цементные или цветные затирки, настенная темпера).

TECHNICAL DETAILS

- ЩЕЛОЧНЫЕ для пятен ОРГАНИЧЕСКОГО типа (Кока-Кола, мороженое, кофе, вино, пиво, животные и растительные жиры, горчица, майонез, кетчуп, варенье, помада, воск).

РАСТВОРИТЕЛЬ для пятен СИНТЕТИЧЕСКОГО типа (силиконовые и механические масла, смолы, эмали). Для полированной отделки Lucidata не рекомендуется использование абразивных средств. При наличии пятен, удаляемых кислотными моющими средствами, необходимо растворить моющее средство в воде, уменьшив в два раза рекомендованную производителем концентрацию кислоты. Кроме того, чрезвычайно важно снизить продолжительность контакта плиты и кислоты, предусмотрев сразу же после чистки промывку большим количеством воды.

Настоятельно рекомендуется не использовать находящиеся в широкой продаже кислоты общего назначения (такие как соляная кислота), потому что они не только удаляют отатки затирки, но и способны неоправимо повредить поверхность плитки. Кроме того, рекомендуется остерегаться средств, содержащих фтористоводородную кислоту (HF), потому что она неоправимо повреждает все керамические поверхности. В том случае, когда предусматривается затирка швов, OLOS рекомендует проводить окончательную чистку после укладки, используя для этого кислотный раствор буферного действия. Смотрите подробности в сводном каталоге Ceramiche Caesar или же на сайте www.caesar.it.

МЕРЫ ПРЕДОСТОРОЖНОСТИ ПРИ ИСПОЛЬЗОВАНИИ

Caesar рекомендует соблюдать следующие указания для предотвращения возникновения проблем или же случайного ущерба:

- не допускайте случайных ударов по углам, кромкам и поверхностям плит;
 - не подвергайте поверхности очень высоким точечным нагрузкам, в особенности на выступающих частях. В частности, не рекомендуется вставать на столешницы ни по какой причине.
 - избегайте использования керамических ножей в прямом контакте со столешницами. На столешницах, выполненных из плит с полированной поверхностью Lucidata, не рекомендуется использование стальных ножей. При каждом использовании ножей рекомендуется защитить поверхность столешницы разделочной доской.
 - Не допускайте прямого контакта с очень горячими предметами, такими как кастрюли, сковороды или кофеварки, пользуйтесь подставками.
 - снизьте до минимума время контакта поверхностей столешницы с высококонцентрированными моющими средствами, как кислотными, так и щелочными. Эта рекомендация касается всех отделок, в особенности полированной Lucidata.
 - не пользуйтесь абразивными моющими средствами для чистки столешниц;
- Caesar не несет никакой ответственности за ущерб или повреждения, вызванные несоблюдением приведенных выше указаний.

Certificazioni dei nostri sistemi di gestione: qualità, ambientale, sicurezza

Our management system certifications: quality, environment, safety

Certifications de nos Systèmes de Gestion: Qualité, Environnement, Sécurité

Zertifizierungen unserer Managementsysteme: Qualität, Umwelt, Sicherheit

Сертификаты наших систем: Менеджмента качества - Экологического менеджмента - Менеджмента безопасности

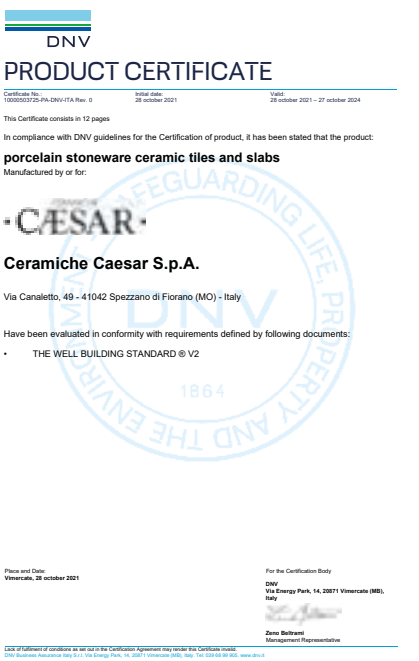
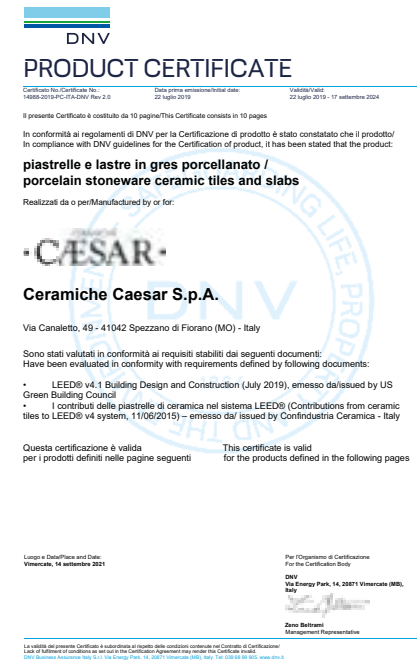

ISO 9001
Rappresenta lo standard di riferimento per la gestione della Qualità delle organizzazioni. I processi interni tendono all'aumento dell'efficacia e dell'efficienza, migliorando la soddisfazione dei clienti.

It is the reference standard for quality management in organisations. Internal processes tend to increase effectiveness and efficiency, improving customer satisfaction.

Il s'agit de la norme de référence pour la gestion de la qualité des organisations. Les processus internes tendent vers l'augmentation de l'efficacité et de l'efficience, en améliorant la satisfaction des clients.

Bezugsstandard für das Qualitätsmanagement von Organisationen. Die internen Prozesse streben die Effizienzsteigerung und eine damit einhergehende, größere Kundenzufriedenheit an.

Базовый стандарт управления Качеством организаций. Внутренние процессы ориентированы на повышение эффективности и продуктивности, что в свою очередь повышает степень удовлетворенности клиентов.



ISO 14001
Attesta che l'organizzazione dispone di un sistema di gestione adeguato a tenere sotto controllo gli impatti ambientali delle proprie attività, e ne ricerca sistematicamente il miglioramento.

It certifies that the organisation has an adequate management system to control the environmental impacts of its activities, and systematically seeks to improve it.

Elle atteste que l'organisation dispose d'un système de gestion apte à contrôler l'impact de ses activités sur l'environnement et cherche systématiquement à l'améliorer.

Bescheinigung darüber, dass die Organisation über ein angemessenes Management-System verfügt, mit dem die Umweltauswirkungen der Aktivitäten unter Kontrolle gehalten und systematisch verbessert werden.

Подтверждает, что организация располагает системой управления, способной держать под контролем уровень влияния своей деятельности на окружающую среду и систематически повышать ее уровень.



ISO 45001
É la più avanzata norma internazionale in materia di sicurezza dei luoghi di lavoro e miglioramento della salute e del benessere dei lavoratori: dimostra come i valori umani e professionali abbiano un ruolo centrale nella nostra azienda.

It is the most advanced international standard for workplace safety and improving the health and well-being of workers: it shows how human and professional values are central to our company.

Il s'agit de la norme internationale la plus importante en matière de sécurité des lieux de travail et d'amélioration de la santé et du bien-être des travailleurs : elle montre que les valeurs humaines et professionnelles jouent un rôle central dans notre entreprise.

Die fortschrittlichste internationale Norm zur Sicherheit am Arbeitsplatz, zur Verbesserung von Gesundheit und Wohlbefinden der Arbeitnehmer: der Beweis dafür, dass menschliche und professionelle Werte in unserem Unternehmen eine zentrale Rolle spielen.

Это самый передовой норматив в сфере безопасности рабочих мест и улучшения состояния здоровья и повышения благосостояния работников. Он показывает, что общечеловеческие и профессиональные ценности занимают центральное место в нашей компании.



PEF (Product Environmental Footprint)
La PEF è una metodologia europea che misura le performance ambientali del prodotto ceramico attraverso tutto il ciclo di vita, considerando svariati criteri.

PEF is a European methodology that measures the environmental performance of ceramic products throughout their life cycle, taking into account several criteria.

PEF est une méthode européenne qui mesure les performances environnementales du produit céramique tout au long de son cycle de vie, en prenant en considération différents critères.

PEF ist eine europäische Methode zur Messung der Leistungen des Keramikprodukts in seinem gesamten Lebenszyklus nach verschiedenen Kriterien.

PEF – это европейская методология, которая измеряет экологические характеристики керамической продукции в течение всего срока службы с учетом разнообразных критериев.



LEED v4.1
Si tratta di uno dei sistemi di certificazione di edifici attualmente più diffusi nel mercato delle costruzioni nordamericano e in tutto il mondo. Caesar si può fregiare del marchio GBC USA in quanto socio ordinario del LEED USA.

It is one of the most popular building certification systems currently used in the North American construction market and worldwide. Caesar can boast the GBC USA mark as an ordinary member of LEED USA.

Il s'agit de l'un des systèmes de certification des bâtiments actuellement les plus répandus sur le marché de la construction en Amérique du Nord et dans le monde entier. Caesar vante également le marque GBC USA, car elle est membre ordinaire de LEED USA.

Eines der zurzeit im nordamerikanischen Bauwesen und in aller Welt verbreitetsten Zertifizierungssysteme für Gebäude. Caesar besitzt als ordentliches Mitglied von LEED USA das Label GBC USA.

Это одна из систем сертификации зданий, наиболее распространенных на строительном рынке Северной Америки и всего мира. Бренд Caesar является гордым обладателем GBC USA и действующим членом LEED USA.



WELL
La nuova e innovativa WELL certifica gli edifici in termini di salubrità, ossia di come l'ambiente possa promuovere la salute e il benessere dei suoi occupanti.

The new and innovative WELL certifies buildings in terms of their healthiness, i.e. how the environment can promote the health and well-being of its occupants.

La nouvelle et innovante certification WELL certifie les bâtiments en termes de salubrité, c'est-à-dire de la manière dont l'environnement peut promouvoir la santé et le bien-être de ses occupants.

Die neue, innovative Zertifizierung WELL ist Nachweis dafür, dass ein Gebäude der Gesundheit und dem Wohlbefinden jener, die sich darin aufhalten, förderlich sein kann.

Новая инновационная сертификация WELL оценивает здания на предмет безопасности для здоровья и демонстрирует, как среда может положительно влиять на здоровье и благосостояние людей.

Certificazioni dei nostri sistemi di gestione: qualità, ambientale, sicurezza

Our management system certifications: quality, environment, safety

Certifications de nos Systèmes de Gestion: Qualité, Environnement, Sécurité

Zertifizierungen unserer Managementsysteme: Qualität, Umwelt, Sicherheit

Сертификаты наших систем: Менеджмента качества - Экологического менеджмента - Менеджмента безопасности



PROGRAMME de vérification INIES Attestation de vérification de la Fiche de Déclaration Environnementale et Sanitaire (FDES)

Dans le cadre de la vérification de la FDES : Carreaux céramiques produits par Ceramich Caesar

Titre complet de la FDES : Carreaux céramiques produits par Ceramich Caesar

N° d'enregistrement de la FDES : 11-1279-2017

Milésime : Février 2019

Date d'édition de l'attestation de vérification : 19/12/2018

Diffusé par : GRUPPO CONCORDE SPA - Via Canalotto 141 41040 Spazzano Di Fiorano, ITALIE

Mr Nicolas BEAULU, vérificateur, titulaire de l'habilitation délivrée le 01/09/2015 et valable jusqu'au 18/09/2021 atteste avoir exercé sa mission en toute indépendance et, sans préjudice des pouvoirs dont dispose l'Etat français pour la supervision au respect des exigences réglementaires :

- ne pas avoir identifié d'écart significatif aux prescriptions du Programme de vérification INIES et de la norme NF EN 15804-A1 et NF EN 15804-CH, les éventuels écarts non significatifs sont listés dans le rapport de vérification ;
- que les données et les informations environnementales et sanitaires figurant dans la FDES susvisée sont plausibles pour le produit objet de la FDES, le propriétaire de la déclaration reste responsable de son intégrité.

Nicolas BEAULU
Le 19/12/2018

Signature :

EVEA S.A.S. au capital de 37 000 € - SIREN 481 273 423 - www.evea-concord.com

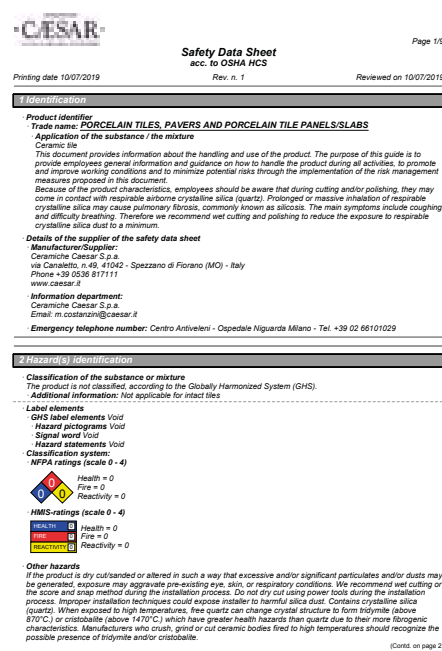

FDES

FDES (Fiche de Déclaration Environnementale et Sanitaire)

Dichiarazione ambientale e sanitaria per il mercato francese, relativa ai prodotti da costruzione e finalizzata a misurarne l'impatto ambientale lungo il loro intero ciclo di vita.

Environmental and Health Declaration for the French market, covering construction products and aimed at measuring their environmental impact throughout their life cycle.

Déclaration environnementale et sanitaire pour le marché français, qui porte sur les produits destinés à la construction et vise à mesurer leur impact sur l'environnement tout au long de leur cycle de vie.

Zu Deutsch Umwelt- und Gesundheitsklärung für den französischen Markt für Baustoffe, die zur Messung ihrer Umweltwirkung über den gesamten Lebenszyklus hinweg dient.

Экологическая и санитарная декларация для французского рынка, присуждаемая строительным материалам, которая оценивает их влияние на окружающую среду в течение всего срока службы.



EPD

EPD (Environmental Product Declaration)

Questa certificazione attesta la trasparenza del singolo prodotto, in riferimento all'impatto ambientale che va dall'estrazione delle materie prime, alla spedizione e al successivo utilizzo finale.

This certification proves the transparency of the individual product with regard to its environmental impact from the extraction of the raw materials through to shipment and final use.

Il s'agit d'une certification qui atteste la transparence de chaque produit en termes d'impact sur l'environnement, de l'extraction des matières premières à l'expédition et à l'utilisation finale.

Nachweis der Transparenz jedes einzelnen Produkts hinsichtlich seiner Umweltwirkung, von der Rohstoffgewinnung bis zum Versand und zur anschließenden Nutzung der Fliesen.

Этот сертификат демонстрирует прозрачность каждого отдельного продукта в плане воздействия на окружающую среду: от получения первичного сырья до отправки готового продукта и его последующего использования конечным потребителем.

MSDS

MSDS (Material Safety Data Sheet)

Documento in cui vengono elencati tutti i pericoli per la salute e la sicurezza dell'uomo e dell'ambiente di un prodotto. In Europa la struttura delle schede di sicurezza è normata dal regolamento REACH.

A document listing all hazards to human health and safety and the environment of a product. In Europe, the structure of safety data sheets is regulated by the REACH regulation.

Fiche des Données de Sécurité - document qui indique tous les dangers d'un produit pour la santé et la sécurité de l'homme et de l'environnement. En Europe, la structure des fiches de sécurité est réglementée par la norme REACH.

Dokument, in dem alle Gefahren eines Produkts für die Gesundheit und die Sicherheit von Mensch und Umwelt aufgeführt sind. In Europa ist die Struktur der Sicherheits-Datenblätter durch die REACH-Verordnung reglementiert.

Material Safety Data Sheet (паспорт безопасности материала) – это документ, в котором приводятся все риски для здоровья и безопасности человека и природы, которые несет материал. В Европе структура паспорта безопасности устанавливает регламент REACH.

DECLARE

DECLARE

L'innovativa certificazione DECLARE attesta una piena e assoluta trasparenza sulla provenienza, la composizione e le modalità di trattamento e riciclo dei nostri materiali al termine del loro ciclo di vita.

The innovative DECLARE certification provides full and absolute transparency on the origin, composition, treatment and recycling of our materials at the end of their life cycle.

L'innovante certification DECLARE atteste une transparence pleine et absolue quant à la provenance, la composition et les modalités de traitement et de recyclage de nos matériaux au terme de leur cycle de vie.

Die innovative Zertifizierung DECLARE bescheinigt die volle und absolute Transparenz in Sachen Herkunft, Zusammensetzung, Verarbeitung und Recycling unserer Materialien am Ende ihres Lebenszyklus.

Иновационная сертификация DECLARE свидетельствует о полной и абсолютной прозрачности происхождения, состава и способов обработки и переработки наших материалов по истечении срока службы.

ISO 17889-1

ISO 17889-1

Il grès porcellanato Caesar è conforme allo standard ISO 17889-1, che qualifica le piastrelle di ceramica sotto il profilo della sostenibilità. Sviluppata seguendo un approccio di analisi di ciclo di vita, la norma prende in considerazione gli aspetti ambientali, economici e sociali. La norma è costituita da 38 indicatori, con un meccanismo a punteggio premiante, che permette di valorizzare il proprio livello di sostenibilità.

Caesar porcelain stoneware complies with the ISO 17889-1 standard, which qualifies ceramic tiles in terms of sustainability. Developed following a life cycle analysis approach, the standard takes into consideration environmental, economic and social aspects. The standard consists of 38 indicators, with a rewarding score mechanism, which allows you to enhance your level of sustainability.

Le grès cérame Caesar est conforme à la norme ISO 17889-1, qui qualifie les carreaux en céramique du point de vue de la durabilité. Il est développé selon une approche d'analyse du cycle de vie, la norme tient compte des aspects environnementaux, économiques et sociaux. La norme est constituée de 38 indicateurs, avec un mécanisme à score, qui permet de valoriser son niveau de durabilité.

Das Feinsteinzeug aus dem Hause Caesar entspricht der Norm ISO 17889-1, die Keramikfliesen im Hinblick auf Nachhaltigkeit qualifiziert. Der nach einem Lebenszyklusanalyse-Ansatz entwickelte Standard berücksichtigt ökologische, ökonomische und soziale Aspekte. Der Standard besteht aus 38 Indikatoren mit einem Bewertungsmechanismus, der es Ihnen ermöglicht Ihr Nachhaltigkeitsniveau zu verbessern.

Керамогранит Caesar соответствует стандарту ISO 17889-1, который квалифицирует керамическую плитку с точки зрения экологичности. Стандарт, разработанный на основе анализа жизненного цикла, учитывает экологические, экономические и социальные аспекты. Стандарт состоит из 38 показателей с механизмом начисления баллов, который позволяет повысить уровень устойчивости.

Certificazioni e analisi

Certifications and analyses
Certifications and analyses
Zertifizierungen und Analysen
Сертификаты и анализы

Il grès fine porcellanato Caesar è garantito dai principali organismi ufficiali di certificazione a livello internazionale.

Caesar fine porcelain stoneware is guaranteed by major international certifying institutions.

Le grès cérame fin Caesar est garanti par les principaux organismes officiels de certification au niveau international.

Das Feinsteinzeug Caesar ist weltweit von den bedeutendsten öffentlichen Zertifizierungsorganen garantiert.

Тонкий фарфоровый керамогранит Caesar имеет гарантию основных международных органов по сертификации

Certificat Certificate

0832 - Carreaux céramiques pour revêtements de sol
N° 148-32.2/21

QB UPEC

Le CSTB accorde le droit d'usage de la marque QB à la société :
CERAMICHE CAESAR SPA
41042 SPEZZANO DI FIORANO (MO) Italie

Usine de production : 148
41042 VIA CANALETTO SPEZZANO DI FIORANO (MO) Italie

La validité de ce certificat et la liste des produits certifiés sont vérifiables sur le site Internet au en faisant le QR-code ci-contre.

Decision de Certification / Certification decision n° 148-32.21 - 01/09/2022

Fait à : **Mame la Vallée, France.**
Date : 14/09/2022

CSTB

Certificat Certificate

0832 - Carreaux céramiques pour revêtements de sol
N° 148-F-3.1/21

QB UPEC-F+

Le CSTB accorde le droit d'usage de la marque QB à la société :
CERAMICHE CAESAR SPA
41042 SPEZZANO DI FIORANO (MO) Italie

Usine de production : 148
41042 VIA CANALETTO SPEZZANO DI FIORANO (MO) Italie

La validité de ce certificat et la liste des produits certifiés sont vérifiables sur le site Internet au en faisant le QR-code ci-contre.

Decision de Certification / Certification decision n° 148-F-3.1 - 01/09/2022

Fait à : **Mame la Vallée, France.**
Date : 14/09/2022

CSTB

CERTIFICATE FOR CHINA COMPULSORY PRODUCT CERTIFICATION

CERAMICHE CAESAR S.p.A.
Via Canaletto 49-41042 Spezzano di Fiorano (MO) Italy

CERAMICHE CAESAR S.p.A.
Via Canaletto 49-41042 Spezzano di Fiorano (MO) Italy

PORECLAIN TILES

Factory's Quality Assurance Ability & Check of consistency of the product

VALIDITY FROM: 2006 REVISION DATE: Nov 04, 2011

NO. 11, Baofu Road, Suzhou District, Suzhou, P.R. China 215001

TEST REPORT n. 3813/2021/I

CERAMIC TILES - DETERMINATION OF WATER ABSORPTION
UNI EN ISO 10545-3:2018

Date of report: 06/30/2021

Customer: CERAMICHE CAESAR S.p.A.
Via Canaletto, 49
41042 Spezzano di Fiorano (MO)

Requested on: 06/30/2021

Our ref number: 30680

Execution place of tests: Scandiano (RE)

Description of the sample: "Ceramic tiles enameled-serie KEYMOOD" unglazed 60x120 cm

Sampling: carried out by the customer

Receipt date of samples: 06/11/2021

Execution date of tests: start: 06/24/2021 end: 06/25/2021

Test specification: UNI EN ISO 10545-3:2018

Warnings: This test report can not be reproduced in part, without our written consent. The reported results relate only to the samples tested. The information included in quotation marks was provided by the customer.

RP 003.1 in Rev.1 - 08/11/2019

TCNA TEST REPORT NUMBER: TCNA-0302-20

TEST REQUESTED BY: Caesar Ceramics USA

TEST METHOD: ASTM C373-18: "Standard Test Methods for Determination of Water Absorption and Associated Properties by Vacuum Method for Pressed Ceramic Tiles and Glass Tiles and Bulk Method for Extruded Ceramic Tiles and Non-tile Fired Ceramic Whiteware Products"

Informal Test Method Description: This test method covers procedures for determining water absorption, bulk density, apparent porosity, and apparent specific gravity of non-tile fired unglazed whiteware products, glazed or unglazed ceramic tiles, and glass tiles. The water absorption, reported here, is expressed as a percent, the relationship of the mass of water absorbed to the mass of the dry specimen.

TEST SUBJECT MATERIAL: Identified by client as: "serie ENCHANT" Approximate Size as Received: 8"x40"

TEST DATE: 4/6/2020

TEST PROCEDURE NOTES

- Sample prep: Five (5) tiles were cut according to section 5.2 of ASTM C373-18.
- Samples were dried to a constant mass at a temperature of 150°C and cooled to room temperature in a desiccating unit.
- Samples were subjected to vacuum of 91 ± 5 kPa for 30 minutes. While maintaining the vacuum, water was added to the tank to fully submerge the specimens. The vacuum was then released and the pressure vessel was allowed to return to atmospheric pressure. Once at atmospheric pressure the test specimens were allowed to soak for 15 minutes.
- Saturated mass of the samples was measured after the 15 minute soak period.
- Water absorption is calculated by using the following formula: $(M - D)/D \times 100$ Where; D is the constant dry mass; M is the saturated mass

| Sample | Water Absorption (%) |
|----------|----------------------|
| Sample 1 | 0.1% |
| Sample 2 | 0.1% |
| Sample 3 | 0.1% |
| Sample 4 | 0.1% |
| Sample 5 | 0.2% |
| Average | 0.1% |

COMMENTS: None

MODENA CENTRO PROVE s.r.l.

RAPPORTO DI PROVA : 20215298/1

Modena, 19/07/21

CLIENTE: CERAMICHE CAESAR SPA - VIA CANALETTO 49 - FRAZ. SPEZZANO - 41042 - FIORANO MODENESE - MO

MATERIALE e/o CAMPIONE in prova: Piastrelle in gres porcellanato; serie KEYMOOD GRP.

Denominazione: 11502021;

Data di ricevimento campione: Determinazione della Scivolosità

Tipo di Prova effettuato: D.M. 236 - 89 P.R.S.C.R.

Norma/Metodo di riferimento: Nessuno

Scostamenti dalla Norma/Metodo: Scivolometro Tortus cod. C142

Strumentazione utilizzata: Nessuna

Fasi subappaltate: Nessuna

Campionamento a cura di: Cliente

Il risultato delle prove riportate nel presente Rapporto di Prova si riferiscono unicamente ai campioni prelevati dal nostro personale e/o incaricato dal Committente; questi si impegna a riprodurre integralmente questo documento. E' vietata ogni forma di riproduzione parziale. I nomi di conservazione dei campioni sono indicati sull'offerta o contratto o sul presente Rapporto di Prova di riferimento.

Page 1 of 2 del Rapporto di Prova n° 20215298/1

La liste a jour des produits et formats des series certifiees QB-UPEC est disponible en usine.

La liste a jour des produits et formats des series certifiees QB-UPEC F+ est disponible en usine.

Pose sur plots

CSTB
L'UPEC è un sistema di classificazione funzionale dei prodotti da pavimentazione che attesta se un prodotto sia adeguato all'utilizzo in un certo locale.

UPEC is a functional classification system for flooring products that states whether a product is suitable for use in a certain facility.

L'UPEC est un système de classification fonctionnelle des produits destinés aux sols, qui atteste qu'un produit est apte à être utilisé dans un espace donné.

UPEC ist ein französisches System der funktionalen Klassifizierung von Bodenbelägen, mit dem die Eignung eines Produkts für einen bestimmten Raum bescheinigt wird.

UPEC – это система функциональной классификации напольной продукции, которая устанавливает, подходит ли она для использования на определенной территории.

CCC (China Compulsory Certification)
Norma i requisiti tecnici e ambientali dei prodotti al fine di consentire la loro commercializzazione sul territorio cinese.

Standardises the technical and environmental requirements of products in order to allow them to be marketed in China.

Norme indiquant les exigences techniques et environnementales des produits afin d'autoriser leur commercialisation sur le territoire chinois.

Richtlinie über die technischen und umweltbezogenen Voraussetzungen für den Vertrieb in China.

Устанавливает технические и экологические требования к продукции для продажи на территории Китая.

CENTRO CERAMICO

LABORATOIRE D'ESSAI
RAPPORT D'ESSAI N° 2176/21

A la demande de: CERAMICHE CAESAR
Via Canaletto, 49
41042 Spezzano di Fiorano (MO)

En date du: 16/02/21

Pour le produit marqué: "EL OYSTER 60 RETT AFD"

Les résultats donnés dans ce rapport d'essai ne s'appliquent qu'aux échantillons soustraits aux essais. La précision de l'échantillonnage n'engage notre responsabilité que si elle est effectuée sous notre propre surveillance. La reproduction de ce rapport d'essai n'est autorisée que sous forme de photocopie intégrale. Toute reproduction partielle nécessite notre autorisation écrite. Les textes entre guillemets sont des déclarations de Client et donc de sa responsabilité. Ce rapport d'essai comporte 2 pages, lecture la présente.

Via Marconi 26
40138 Bologna - Italy
Tel. +39 051 534015
Fax +39 051 534005
Part IVA 0964738039

centro.ceramico@centroceramico.it
www.centroceramico.it

Viale Vialli d'Azio 1
41042 Santeramo S.P. - Italy
Tel. +39 0536 802154
Fax +39 0536 802062

Caesar per il LEED V4.1

Caesar for LEED V4.1

Il sistema di certificazione volontaria LEED (Leadership in Energy and Environmental Design), sviluppato dallo US Green Building Council (USGBC) e sempre più diffuso in ambito internazionale, consiste in una serie di standard per la misurazione dell'efficienza energetica e dell'impronta ecologica degli edifici. Gli standard del sistema sono applicabili all'intero ciclo di vita degli edifici: dalla loro progettazione, alle attività di manutenzione, ai restauri. Per ulteriori approfondimenti consultare il Certificato DNV disponibile in azienda o sul sito www.caesar.it

The LEED (Leadership in Energy and Environmental Design) voluntary certification system developed by the US Green Building Council (USGBC) is the most widely spread international series of standards for measuring the energy efficiency and sustainability of buildings. The system's standards apply to the entire life-cycle of buildings: from design, to maintenance and renovation. For more detailed information, refer to the DNV certification or to the www.caesar.it website.

| FINALITÀ - OBJECTIVE | REQUISITI - REQUISITES | PRODOTTI CAESAR - CAESAR PRODUCT | CREDITI - CREDIT |
|----------------------------------------------------------------------------------------------------------------------------------------------------------------------------------------------------------------------------------------------------------------------------------------------------------------------------------------------------------------------------------------------------------------------------------------------------------------------------------------------------------------------------------------------------------------------------------------------------------------------------|-------------------------------------------------------------------------------------------------------------------------------------------------------------------------------------------------------------------------------------------------------------------------------------------------------------------------------------------------------------------------------------------------------------------------------------------------------------------------------------------------------------------------------------------------------------------------------------------------------------------------------------------------------------------------------------------------------------------------------------------------------------------------------------------------------------------------------------------------------------------------------------------------------------------------------------------------------------------------------------------------------------------------------------------------------------------------------------------------------------------------------------------------------------------------------------------------------------------------------------------------------------------------------------------------------------------------------------------------------------------------------------------------------------------------------------------------------------------------------------------------------------------------------------------------------------------------------------------------------------------------------------------------------------------------------------------------------------------------------------------------------------------------------------------------------------------------------------------------------------------------------------------------------------------------------------------------------------------------------------|----------------------------------------------------------------------------------------------------------------------------------------------------------------------------------------------------------------------------------------------------------------------------------------------------------------------------------------------------------------------------------------------------------------------------------------------------------------------------------------------------------------------------------------------------------------------------------------------------------------------------------------------------------------|--------------------------------------------------------------------------------------------------------------------------------------------------------------------------------------------------------------------------------------------------------------------------------|
| SITI SOSTENIBILI (SS) - SUSTAINABLE SITES (SS) | | | |
| Ridurre al minimo gli effetti isola di calore sul microclima e sull'habitat. - To reduce the influence of the heat island effect on the microclimate and natural habitats to the absolute minimum. | RIDUZIONE DELL'EFFETTO ISOLA DI CALORE - HEAT ISLAND EFFECT REDUCTION. | Le piastrelle di colore chiaro della gamma Caesar, utilizzate in spazi esterni, contribuiscono a ridurre l'effetto isola di calore (differenza di gradiente termico tra aree urbane e extraurbane) per ridurre al minimo l'impatto sul microclima. Tutto ciò grazie agli alti valori di coefficiente di riflettanza solare SRI dei prodotti Caesar. - The light-colored tiles of the Caesar range, used in outdoor areas, help reduce the heat island effect (the thermal gradient difference between urban and suburban areas) to minimize the impact on the microclimate. All thanks to the high values of solar reflectance coefficient of Caesar products. | Riduzione dell'effetto isola di calore. Heat island effect reduction. - Non tetto (pavimentazione esterna) - Not roofs (exterior paving) - Tetto (ad eccezione di Healthcare che dà 1 punto) - Roofs (with the exception of Healthcare that gives 1 point) |
| MATERIALI E RISORSE (MR) - MATERIALS AND RESOURCES (MR) | | | |
| Impegnarsi ad utilizzare prodotti e materiali con un basso impatto ambientale, economico e sociale e per i quali sono disponibili informazioni sull'intero ciclo di vita. - Commit to using products and materials with low environmental, economic and social impact and for which information is available on the entire life cycle. | DISPONIBILITÀ DI EPD CERTIFICATA. CERTIFIED EPD AVAILABLE. L'EPD rappresenta una sorta di carta d'identità dei prodotti e ne descrive l'impatto sull'ambiente durante tutte le fasi del ciclo di vita: dalla fase di estrazione delle materie prime, fino allo smaltimento. - EPD can be thought of as a virtual identity card for products and describes their impact on the environment during all stages of the life cycle: from extraction of raw materials to their disposal. | Caesar dispone di una EPD certificata da un ente esterno indipendente - Caesar has an EPD certified by an independent external body (EPD ITALY) . | Trasparenza ed ottimizzazione dei prodotti per l'edificio - EPD - Dichiarazione ambientale di prodotto. Building product disclosure and optimization - EPD - Environmental product declaration |
| | FONTE DI MATERIE PRIME E SEGNALEZIONE DI ESTRAZIONE. RESPONSIBLE SOURCING OF RAW MATERIALS. | Questo credito si applica ai prodotti Caesar elencati nell'appendice 1 del certificato DNV, disponibile in azienda o sul sito www.caesar.it . This credit is applicable for Caesar products listed in the appendix 1 of DNV Certificate available in the company or on the website www.caesar.it | Trasparenza ed ottimizzazione dei prodotti per l'edificio - Fonte delle materie prime - Building product disclosure and optimization - Source of raw materials |
| | Utilizzare prodotti provenienti da almeno tre diversi produttori, che rispettano almeno uno dei criteri riportati, per almeno il 20% in costo, del valore totale dei prodotti da costruzione installati in modo permanente nel progetto. (1 punto) Utilizzare prodotti provenienti da almeno cinque diversi produttori, che rispettano almeno uno dei criteri riportati, per almeno il 40% in costo, del valore totale dei prodotti da costruzione installati in modo permanente nel progetto. (2 punti) Contenuto di materiale riciclato. Prodotti che rispettano il requisito del contenuto di materiale riciclato sono valutati al 100% del loro costo per il calcolo del raggiungimento del credito. - Il contenuto di materiale riciclato è dato dalla somma del contenuto di riciclato "post-consumer" + ½ del contenuto di riciclato pre-consumer, basato sul peso. - Il contenuto di riciclato va poi moltiplicato per il costo, per determinare il contenuto complessivo di riciclato. Use products sourced from at least three different manufacturers that meet at least one of the responsible sourcing and extraction criteria below for at least 20%, by cost, of the total value of permanently installed building products in the project. (1 point). Use products sourced from at least five different manufacturers that meet at least one of the responsible sourcing and extraction criteria below for at least 40%, by cost, of the total value of permanently installed building products in the project (2 points). Recycled content. Products meeting recycled content criteria are valued at 100% of their cost for the purposes of credit achievement calculation. - Recycled content is the sum of postconsumer recycled content plus one-half the preconsumer recycled content, based on weight. - The recycled fraction of the assembly is then multiplied by the cost of assembly to determine the recycled content value. | | 1-2 |
| Verifica della minimizzazione dell'uso e della generazione di sostanze nocive. - Verification on to minimization of the use and generation of harmful substances. | TRASPARENZA NELL'USO DEI MATERIALI. TRANSPARENCY IN THE USE OF MATERIALS. | Caesar dispone dell'etichetta Declare in corso di validità; le affermazioni contenute in tale dichiarazione sono sostenute da elementi oggettivi. - Ceramiche Caesar has the Declare product label; the statements contained in this declaration are supported by evidences. Caesar non utilizza per la realizzazione dei propri prodotti sostanze appartenenti alla lista Reach o inserite nella Candidate List. - Caesar does not use substances belonging to the Reach or Candidate list for the manufacturing of its products. | Trasparenza ed ottimizzazione dei prodotti per l'edificio - ingredienti dei materiali. - Building product disclosure and optimization - material ingredients. |
| | Opzione 1. Report degli ingredienti dei materiali. Utilizzare prodotti installati in modo permanente che utilizzano uno dei seguenti programmi per l'inventario chimico del prodotto, per sostanze con concentrazione maggiore o uguale a 0,1% (1000 ppm). Declare: l'etichetta Declare dovrà rispondere ai seguenti requisiti: - Rispondere al requisito "Red List Free" oppure "Declared". - Essere conforme ad LBC (Living Building Challenge) e dimostrare un inventario fino allo 0,1% (1000 ppm). Option 1. Material ingredient reporting. Use permanently installed products that use any of the following programs to demonstrate the chemical inventory of the product to at least 0,1% (1000 ppm). Declare: the Declare product label must meet the following requirements: - Declare labels designated as Red List Free or Declared. - Declare labels designated as LBC Compliant that demonstrate content inventory to 0,1% (1000 ppm). Opzione 2. Ingredienti dei materiali - ottimizzazione (1 punto): Inventario e verifica avanzati (valutato al 100% del costo, oppure 1 prodotto). - Etichetta "Declare" valutata come "Red list Free", verificata da ente indipendente di terza parte. - Percorso Internazionale Alternativo - REACH Optimization. (valutato al 100% del costo, oppure 1 prodotto). Option 2. Material ingredient optimization (1 point) Advanced Inventory & Assessment (value at 100% by cost or 1 product). - Declare labels designated as Red List Free that are third-party verified. - International Alternative Compliance Path - REACH Optimization (value at 100% of cost or 1 product). | | 1 |
| | | | 1 |
| QUALITÀ AMBIENTALE INTERNA (IEQ) - INDOOR ENVIRONMENTAL QUALITY (IEQ) | | | |
| Riguarda l'emissione di composti organici volatili (VOC) nell'aria indoor e i VOC contenuti nei materiali, così come le metodologie di test secondo le quali le emissioni di VOC all'interno dell'edificio sono misurate. Materiali diversi devono essere conformi a diversi requisiti per essere considerati conformi a questo credito. - It covers volatile organic compound (VOC) emissions into indoor air and the VOC content of materials, as well as the testing methods by which indoor emissions are determined. Different materials must meet different requirements to be considered compliant for this credit. | - Ridurre la concentrazione di contaminanti chimici che possano compromettere la qualità dell'aria, la salubrità, la produttività e l'ambiente. Prodotti che rispondono a tale requisito (pietra, ceramica, metallo, vetro, cemento, mattoni di argilla, etc) sono considerati completamente conformi senza necessità di condurre alcun tipo di test. - To reduce the concentrations of chemical contaminants that can damage air quality, human health, productivity, and the environment. Products that are an inherently nonemitting sources of VOCs (stone, ceramic, powder-coated metals, plated or anodized metal, glass, concrete, clay brick, and unfinished or untreated solid wood flooring) are considered fully compliant without any VOC emissions testing. | - I prodotti Caesar non rilasciano alcuna sostanza organica volatile nell'ambiente. (VOC - volatile organic compounds). - Caesar products do not release any volatile organic substances (VOC) into the environment. | Materiali basso - emissivi Low - emitting materials |
| | | | 1-3 |

Informazioni commerciali

Commercial information - Informations Commerciales

Verkaufs informationen - Коммерческая Информация

TECHNICAL DETAILS

CONDIZIONI GENERALI DI VENDITA del 1 Gennaio 2021

A.- MODALITÀ DI CONCLUSIONE DEL CONTRATTO

A.1.- Le presenti Condizioni Generali di Vendita disciplinano ogni contratto di Vendita tra il Venditore e l'Acquirente ed ogni loro modifica o deroga deve essere concordata per iscritto.

A.2.- Eventuali offerte, accrediti e/o abbuoni accordati da agenti o da altri intermediari, non sono ritenuti validi se non confermati per iscritto dal Venditore.

A.3.- L'Acquirente invia al Venditore, direttamente o per il tramite di agenti, Ordini scritti che devono contenere l'indicazione dei codici dei Prodotti richiesti, delle quantità, del loro prezzo e della destinazione. L'Ordine inviato dall'Acquirente è irrevocabile.

A.4.- La Vendita dovrà ritenersi conclusa nel momento in cui: (i) l'Acquirente riceve da parte del Venditore una Conferma scritta via e-mail, fax o altri mezzi telematici, conforme ai termini e alle condizioni dell'Ordine; o (ii) in caso di Conferma inviata dal Venditore contenente condizioni difformi dall'Ordine ricevuto dall'Acquirente quando questi l'accetti per iscritto o comunque non la contesti entro 7 (sette) giorni dalla ricezione; o (iii) in assenza di conferma scritta da parte del Venditore, nel momento in cui i Prodotti saranno consegnati e caricati dall'Acquirente

A.5.- L'Acquirente condivide l'esigenza di limitare al territorio nazionale le vendite di prodotti Caesar. Il Venditore ritiene questa regola elemento indispensabile per permettergli di coordinare la sua politica commerciale e razionalizzare la rete distributiva, con offerte più orientate alle necessità dei singoli Paesi. Parimenti, l'Acquirente riconosce che tale esigenza costituisce una tutela anche dei propri interessi. L'Acquirente si obbliga quindi a commercializzare i prodotti forniti da Ceramiche Caesar SpA esclusivamente nel suo Paese di residenza, astenendosi dal promuovere vendite attive sollecitate anche online con clienti situati nel territorio di uno Stato diverso dal proprio. Per le operazioni triangolari il presente obbligo si applica al Paese di effettiva operatività dell'acquirente. L'Acquirente potrà rivendere il prodotto al di fuori dal proprio territorio nel caso in cui riceva autorizzazione per iscritto da parte del Venditore, o nel caso in cui la rivendita riguardi prodotti non di prima scelta, oppure prodotti fuori produzione.

B.- PREZZI

B.1.- Salvo diversa pattuizione scritta, i prezzi di vendita concordati di volta in volta si intendono al netto per contanti e per consegna franco stabilimento del Venditore indicato nella Conferma d'Ordine.

C.- CARATTERISTICHE DEI PRODOTTI

C.1.- L'Acquirente dichiara di aver preso visione ed attenersi al contenuto della seguente documentazione pubblicata nel sito internet aziendale: 1) Manuale di Posa, Uso, Pulizia e Manutenzione e 2) Schede tecniche.

C.2. Data la intrinseca variabilità del prodotto ceramico, le caratteristiche dei campioni e/o modelli inviati in precedenza dal Venditore all'Acquirente sono da considerarsi indicativi e non vincolanti.

C.3. Salvo specifiche richieste da concordare prima della Conferma d'Ordine, il Venditore non garantisce che l'ordine del singolo articolo venga evaso tutto con un medesimo lotto di produzione.

D.- TERMINI DI CONSEGNA

D.1.- I termini di consegna sono da intendersi indicativi e la proroga di essi non può far maturare all'Acquirente alcun diritto a richiedere indennizzi, ogni eccezione rimossa.

D.2.- Se, trascorsi 10 (dieci) giorni dalla data di avviso di merce pronta, l'Acquirente non ritira il materiale, il Venditore si riserva di stabilire discrezionalmente un nuovo termine di consegna.

E.- RESA E SPEDIZIONE

E.1.- L'eventuale variazione della destinazione dei Prodotti, diversa da quella concordata in Conferma d'Ordine, deve essere comunicata dall'Acquirente per iscritto entro e non oltre il secondo giorno antecedente a quello previsto per il ritiro presso la sede del Venditore. Il Venditore si riserva la facoltà di non accettare la variazione della destinazione dei Prodotti. Nel caso si verifichi che la destinazione effettiva del Prodotto sia stata diversa da quella dichiarata dall'Acquirente, il Venditore si riserva la facoltà di sospendere l'esecuzione delle forniture in corso e/o risolvere i contratti in corso senza che l'Acquirente possa rivendicare risarcimenti diretti e/o indiretti di alcun tipo.

E.2.- Salvo patto contrario, la fornitura della merce si intende Franco Fabbrica (EXW ai sensi degli Incoterms 2010) e ciò anche quando sia convenuto che la spedizione o parte di essa venga curata dal Venditore su mandato dell'Acquirente. In ogni caso i rischi passano all'Acquirente al più tardi con la consegna al primo trasportatore.

E.3.- Ferma restando l'estraneità del Venditore rispetto al contratto di trasporto, il Venditore non potrà essere indicato come "shipper" nella polizza di carico. La comunicazione del peso lordo del container allo spedizioniere, non costituisce alcuna assunzione di responsabilità da parte del Venditore ai fini della Convenzione SOLAS (Safety Of Life At Sea). In nessun caso tale comunicazione potrà essere intesa come VGM (Verified Gross Mass).

E.4.- L'Acquirente s'impegna affinché il mezzo inviato presso i magazzini del Venditore sia idoneo al carico in relazione alla natura dei Prodotti. Nel caso il mezzo che si presenta comporti significative difficoltà per le operazioni di carico, il Venditore si riserva di addebitare una penale pari al 4% del valore dei prodotti a copertura dei maggiori costi logistici. Se il mezzo convenuto non è assolutamente idoneo, il Venditore si riserva la facoltà di negare le operazioni di carico senza che nulla possa essere richiesto dall'Acquirente a titolo di risarcimento per ogni onere diretto e/o indiretto che ne possa derivarne.

E.5.- È compito dell'Acquirente incaricare il vettore di controllare i prodotti prima del carico; eventuali osservazioni in relazione all'integrità degli imballi e della rispondenza delle quantità caricate a quelle indicate sul documento di trasporto, devono essere sollevate dal vettore al momento del carico. Tali osservazioni devono essere riportate su tutte le copie dei documenti di trasporto, altrimenti i prodotti caricati s'intendono integri e completi. Ne deriva che il Venditore non si assume alcuna responsabilità in relazione a mancanze o danni dei prodotti non segnalati dal vettore.

E.6.- È altresì responsabilità dell'Acquirente incaricare il vettore di verificare le modalità e la stabilità del carico sul mezzo affinché durante il trasporto non si verifichino rotture e affinché siano rispettate tutte le disposizioni di sicurezza riguardanti la circolazione stradale.

F.- PAGAMENTI

F.1.- Qualsiasi obbligazione di pagamento deve essere adempiuta presso la sede legale del Venditore. Eventuali pagamenti ad agenti, rappresentanti o ausiliari di commercio non si intendono effettuati finché le relative somme non pervengono al Venditore.

F.2.- È fatto divieto all'Acquirente di eseguire il proprio adempimento mediante pagamenti provenienti da paesi diversi dal proprio paese di residenza se trattasi di paesi che non garantiscono un adeguato scambio di informazioni con l'Italia. In caso di violazione di tale divieto, il Venditore ha facoltà di risolvere il contratto per giusta causa senza che l'Acquirente possa vantare il diritto di ottenere alcun risarcimento per l'eventuale danno subito.

F.3.- Eventuali spese di bollo ed incasso effetti e tratte sono a carico dell'Acquirente. In caso di inadempimento, anche solo parziale, dal giorno fissato per il pagamento decorreranno a favore del Venditore gli interessi moratori nella misura prevista dal d.lgs. 09/10/2002 n. 231.

F.4.- Salvo diversi accordi scritti, l'Acquirente si impegna a non compensare alcun credito, comunque insorto, nei confronti del Venditore.

G.- RECLAMI

G.1.- Al ricevimento dei Prodotti, l'Acquirente dovrà sottoporli ad accurato controllo attraverso un esame visivo effettuato conformemente alle indicazioni riportate al punto 7 delle norme UNI EN ISO 10545-2

G.2.- L'installazione e la posa dei Prodotti deve essere effettuata attenendosi scrupolosamente alle raccomandazioni inerenti le attività da svolgere prima e durante la posa in opera indicate nel documento 1) Manuale di Posa, Uso, Pulizia e Manutenzione pubblicato nel sito internet del Venditore e sulla confezione del prodotto e/o all'interno della stessa. Non sono considerati vizi del Prodotto quelli generati da un'errata installazione e dalla mancata/errata manutenzione (difformi dalle indicazioni fornite nel 1) Manuale di Posa, Uso, Pulizia e Manutenzione), da una non idonea destinazione d'uso e/o dalla normale usura nel tempo.

G.3.- Fatti salvi i limiti di accettabilità previsti dalla norma internazionale EN 14411 (ISO 13006), le Parti riconoscono come Vizi Palesi i difetti dei Prodotti riscontrabili già al momento del loro ricevimento tali da rendere il materiale inadatto all'uso o da diminuirne in modo apprezzabile il valore. Rientrano in tale categoria i difetti come definiti nel documento 1) Manuale di Posa, Uso, Pulizia e Manutenzione pubblicato sul sito internet del Venditore. A titolo esemplificativo e non esaustivo si riconoscono come Vizi Palesi i difetti superficiali, i difetti di decorazione, di lappatura/levigatura, di calibro, di planarità, di ortogonalità-rettilineità, di spessore, le crepe, le sbecature, i fuori tono, i toni mescolati e i Prodotti che presentano problemi da taglio/scaglie.

G.4.- Nel caso l'Acquirente rilevi Vizi Palesi dovrà fare reclamo al Venditore per iscritto, a pena di decadenza, entro 8 (otto) giorni dal ricevimento e tenere a disposizione del Venditore l'intera partita di materiale. Il reclamo dovrà riportare i dati di fatturazione e una precisa descrizione del vizio reclamato corredata, quando possibile, da immagini fotografiche. Qualora il reclamo dovesse risultare infondato, l'Acquirente si rende disponibile a risarcire il Venditore delle spese sostenute per l'eventuale sopralluogo (perizie, viaggi ecc.).

G.5.- I Vizi Occulti dovranno essere notificati al Venditore mediante lettera raccomandata A.R., a pena di decadenza dalla garanzia, entro 8 (otto) giorni dalla data della scoperta del difetto.

G.6.- L'azione dell'Acquirente diretta a fare valere la garanzia per vizi si prescrive comunque nel termine di 12 (dodici) mesi decorrenti dalla consegna dei Prodotti.

H.- GARANZIA PER VIZI

H.1. La garanzia del Venditore si intende limitata ai soli Prodotti di prima scelta e non ai Prodotti di seconda o terza scelta o di partite d'occasione con prezzi o sconti particolari quando debitamente segnalati in nota nella Conferma dell'Ordine.

H.2. Il Venditore non garantisce l'idoneità dei Prodotti ad usi particolari, ma soltanto le caratteristiche tecniche pubblicate sul sito internet nel documento 2) Schede tecniche. L'indicazione d'uso, anche quando presentata dal Venditore in cataloghi e manuali, è da ritenersi puramente indicativa. Sulla base delle caratteristiche tecniche riportate nelle 2) Schede Tecniche è sempre compito del progettista valutare l'idoneità del Prodotto alle condizioni specifiche di utilizzo in funzione delle sollecitazioni e delle variabili che si possono verificare nell'ambiente di destinazione alterandone le sue caratteristiche, a titolo d'esempio, all'intensità del traffico, alla qualità del traffico (calpestio in presenza di sabbia, di detriti...), alle eventuali condizioni climatiche avverse e a qualsiasi altra aleatorietà a cui può essere esposto il materiale.

H.3.- Nel caso risulti accertato che il Prodotto manifesti Vizi Palesi, come definiti al sub lett. G n.3, il Venditore provvederà alla sostituzione del Prodotto difettoso con altro avente caratteristiche pari o superiori o nel caso ciò non sia possibile ad una congrua riduzione del prezzo. In alternativa l'Acquirente avrà diritto, previa restituzione dei Prodotti viziati, al rimborso del prezzo pagato, maggiorato del costo del trasporto, con esclusione del risarcimento di ogni altro danno diretto e/o indiretto.

H.4. La garanzia del Venditore deve ritenersi esclusa nel caso in cui il Prodotto affetto da Vizi Palesi (in tutto o in parte) sia stato utilizzato e/o comunque trasformato dovendosi ritenere che in tal modo l'Acquirente (o il suo cliente) abbia espresso la volontà di accettarli nello stato in cui si trovano.

H.5 Nel caso risulti accertato che il Prodotto manifesti Vizi Occulti, la garanzia del Venditore è limitata alla sostituzione del materiale con altro avente caratteristiche pari o superiori e ove ciò non sia possibile al rimborso del prezzo pagato maggiorato del costo del trasporto. In ogni caso la garanzia del Venditore per ogni danno diretto e/o indiretto comunque originato dal prodotto difettoso, deve intendersi limitata ad una somma che non potrà superare il doppio del prezzo di vendita applicato dal Venditore in relazione alla sola parte della fornitura difettosa.

H.6.- Nel caso l'Acquirente rivenda il Prodotto a soggetti tutelati dal codice del consumo (d.l. n.206/2005) sarà responsabile delle condizioni praticate se difforni da quelle qui riportate e dovrà accertarsi che i diritti del consumatore siano esercitati nel rispetto dei rimedi e dei termini fissati da tale codice. Nel caso sussistano i presupposti, il diritto di regresso e/o comunque di rivalsa spettanti all'Acquirente verso il Venditore/produttore non potrà eccedere le esenzioni ed i limiti come fissati dal sub lett. G n.1 al sub lett. H n.5.

I. CLAUSOLE SOLVE ET REPETE E RISOLUTIVE

I.1.- Ai sensi dell'art. 1462 del Codice Civile, per nessun motivo, ivi compresi pretesi vizi o difetti del materiale, l'Acquirente potrà sospendere o ritardare il pagamento del materiale ritirato, salva naturalmente la facoltà di ripetere quando possa dimostrare di avere indebitamente pagato.

I.2.- Nel caso di mutamento delle condizioni patrimoniali dell'Acquirente o di mancato pagamento anche parziale di prodotti già forniti, il Venditore può sospendere l'esecuzione delle forniture in corso e/o risolvere i contratti in corso senza che l'Acquirente possa rivendicare risarcimenti diretti e/o indiretti di alcun tipo.

L.- PATTO DI RISERVATO DOMINIO

L.1.- Fino a quando l'Acquirente non avrà provveduto all'integrale pagamento del prezzo, i Prodotti oggetto della fornitura rimarranno di proprietà del Venditore.

L.2.- Durante il periodo suddetto, l'Acquirente assumerà gli obblighi e le responsabilità del custode, e non potrà alienare, dare in uso, lasciare sequestrare o pignorare tali Prodotti senza dichiarare la proprietà del Venditore e dare immediato avviso a mezzo raccomandata A.R.

M.- FORZA MAGGIORE

M.1.- Ciascuna parte potrà sospendere l'esecuzione dei suoi obblighi contrattuali quando tale esecuzione sia resa impossibile o oggettivamente troppo onerosa da un impedimento imprevedibile indipendente dalla sua volontà, quale ad esempio: sciopero, boicottaggio, serra, incendio, guerra (dichiarata o non), guerra civile, sommosse e rivoluzioni, requisizioni, embargo, interruzioni di energia, rotture straordinarie di macchinari, ritardi nella consegna di componenti o materie prime.

M.2.- La parte che desidera avvalersi della presente clausola dovrà comunicare immediatamente per iscritto all'altra parte il verificarsi e la cessazione delle circostanze di forza maggiore.

M.3.- Qualora la sospensione dovuta a forza maggiore duri più di 60 (sessanta) giorni, ciascuna parte avrà il diritto di risolvere il presente contratto, previo un preavviso di 10 (dieci) giorni, da comunicarsi alla controparte per iscritto.

N.- OBBLIGO DI RISERVATEZZA

N.1.- L'Acquirente è tenuto ad osservare la più assoluta riservatezza su tutte le notizie di carattere tecnico (quali, in via meramente esemplificativa, disegni, prospetti, documentazioni, formule e corrispondenza) e di carattere commerciale (ivi comprese le condizioni contrattuali, i prezzi d'acquisto, le condizioni di pagamento ...) apprese in esecuzione del presente Contratto.

N.2.- L'obbligo di riservatezza viene assunto per tutta la durata del Contratto, nonché per il periodo successivo alla sua esecuzione.

N.3.- In ogni caso di inosservanza dell'obbligo di riservatezza, la parte inadempiente è tenuta a risarcire all'altra tutti i danni che ne dovessero derivare.

O.- MARCHI E SEGNI DISTINTIVI DEL VENDITORE

O.1.-L'utilizzo dei marchi, dei modelli ornamentali e delle opere d'ingegno in genere, in qualunque forma o modo di espressione (quali a titolo meramente esemplificativo, ma non esaustivo: immagini, foto, disegni, filmati, figure, strutture, etc.) costituenti proprietà intellettuale del Venditore, attraverso qualsiasi mezzo (quali a titolo meramente esemplificativo, ma non esaustivo: stampa, video, radio, internet, social media, piattaforme di messaggistica istantanea o VoIP, etc.) è severamente vietato. Qualsiasi deroga a tale divieto, anche solamente parziale, dovrà essere autorizzata per iscritto, caso per caso, dalla Direzione generale del Venditore.

P.- LINGUA DEL CONTRATTO, LEGGE APPLICABILE, GIURISDIZIONE E COMPETENZA

P.1.- Il Contratto e le presenti condizioni sono redatti in lingua Italiana, la quale prevarrà nel caso di divergenza con la traduzione in altre lingue.

P.2.- La definizione di qualsiasi controversia comunque relativa alle forniture è soggetta alla legge ed alla giurisdizione dello Stato Italiano e la competenza territoriale viene devoluta in via esclusiva al Tribunale di Modena nella cui circoscrizione il Venditore ha la sua sede legale.

GENERAL SALES CONDITIONS of 1st January 2021

A.- CONTRACT COMPLETION

A.1.- These general sales conditions govern every sales contract between the Seller and the Buyer and any amendment or exception thereof shall be agreed in writing.

A.2.- Any offers, credits and/or rebates granted by agents or other intermediaries, shall not be considered valid if they are not confirmed in writing by the Seller.

A.3.- The Buyer shall send the written orders to the Seller, directly or through the agents, and the orders shall include the codes of the required products, quantity, price and destination. The order sent by the Buyer is irrevocable.

A.4.- The sale shall be deemed completed when: (i) the Buyer receives a written confirmation from the Seller, via e-mail, fax or other electronic means, that complies with the terms and conditions of the order; or (ii) if the confirmation sent by the Seller contains conditions that differ from the order sent by the Buyer, when the latter accepts it in writing or in any case does not object within 7 (seven) days from reception; or (iii) if the Seller does not provide a written confirmation, when the products are delivered and loaded by the Buyer.

A.5.- The Buyer shares the need to restrict the sales of Caesar products to the national territory. The Seller deems this rule necessary in order to coordinate its sales policy, streamline its distribution network and provide offers that are suited to the needs of the single countries. The Buyer acknowledges that this rule is also in its best interest. The Buyer therefore undertakes to market the products supplied by Ceramiche Caesar SpA exclusively in its country of residence, refraining from promoting active sales, even online, with customers located in the territory of a country different from its own. As regards triangular operations, this undertaking applies to the country in which the buyer actually operates. The Buyer may resell the product outside its territory only with written authorisation from the Seller, or if the sales concern non first-grade products or products that are out of production

B.- PRICES

B.1.- The prices agreed upon for each individual sale are net prices for cash delivery ex works (the Seller's plant shall be specified in the order confirmation), unless otherwise agreed in writing.

C.- PRODUCT CHARACTERISTICS

C.1.- The Buyer declares to have read and comply with the content of the following documentation published on the corporate website: 1) Laying, use, cleaning and maintenance manual and 2) Technical data sheets.

C.2. Given the intrinsic variability of the ceramic products, the characteristics of the samples, previously sent by the Seller to the Buyer, are purely illustrative and cannot be deemed binding.

C.3. Unless specifically requested and agreed before the order confirmation, the Seller does not guarantee that the entire quantity of an article on order shall be sent from one same production lot.

D.- DELIVERY TERMS

D.1.- The delivery terms are approximate and a delay does not give the Buyer any right to claim compensation, without any exception.

D.2.- If the Buyer does not collect the goods, after 10 (ten) days from the date of the "goods ready" notice, the Seller has the right – at its discretion – to establish a new delivery date.

E.- SHIPPING ARRANGEMENTS AND TERMS

E.1.- The Buyer must communicate any variation in the destination of the products, different from the one agreed in the order confirmation, in writing within, and no later than, the second day before the day foreseen for the collection at the Seller's premises. The Seller reserves the right not to accept the change of the product destination. If the actual destination of the product is different from the one stated by the Buyer, the Seller reserves the right

to suspend the execution of the supplies underway and/or to terminate the contracts in force and the Buyer shall not have the right to claim direct and/or indirect compensation of any type.

E.2.- Unless otherwise agreed, the goods shall be delivered ex-works (EXW - Incoterms 2010) and this shall also be the case when the parties agree that the delivery, or part of it, shall be arranged by the Seller on the Buyer's behalf. In any case, the risks shall transfer to the Buyer upon delivery to the first carrier.

E.3.- Without prejudice to the Seller's extraneity in relation to the transport contract, the Seller shall not be indicated as "shipper" on the bill of lading. The communication of the gross weight of the container to the Forwarding agent does not represent in any way the undertaking of any liability by the Seller as regards the SOLAS (Safety Of Life At Sea) Convention. In no event may the said communication be taken to be the VGM (Verified Gross Mass). E.4.- The Buyer undertakes to ensure that the vehicle sent to the Seller's warehouse is suitable for the loading operations, considering the nature of the products. If the vehicle sent to collect the goods causes difficulties in the loading operations, the Seller reserves the right to charge a penalty, of 4% of the value of the products, to cover the extra logistics costs. If the vehicle sent is not at all suitable, the Seller reserves the right to refuse to load the goods and the Buyer shall not have the right to claim compensation for any direct and/or indirect cost that may arise therefrom.

E.5.- The Buyer is responsible for assigning the carrier the task of checking the products before loading them; any observations concerning the condition of the packaging and the correspondence of the quantities loaded with those on the transport document must be made by the carrier upon collection of the goods. The said observations must be written on all the copies of the transport documents, otherwise the loaded products shall be considered to be complete and in good condition. As a result, the Seller shall not be liable for any missing or damaged products not reported by the carrier.

E.6.- The Buyer is also responsible for assigning the carrier the task of checking the loading procedure and the stability of the goods on the vehicle, in order to prevent damage during transport and to comply with all road safety provisions.

F.- PAYMENTS

F.1.- All payments must be made to the Seller's registered office. Payments made to agents, representatives, or sales assistants shall not be considered as made until the amounts are received by the Seller.

F.2.- The Buyer shall not fulfil its payment obligations by making payments from countries other than its own country of residence, if the said countries do not guarantee an adequate exchange of information with Italy. In case of breach of the said prohibition, the Seller has the right to terminate the contract for just cause and the Buyer shall not have the right to claim compensation for any damage suffered.

F.3.- Any costs for stamp duty and bank draft fees shall be borne by the Buyer. Failure to fulfil, even only in part, the payment shall result in the application of interest on arrears in favour of the Seller, from the date established for the payment, as envisaged by legislative decree 09/10/2002 no. 231.

F.4.- Unless otherwise agreed in writing, the Buyer undertakes not to offset any receivables, of whatever nature, owed by the Seller.

G.- CLAIMS

G.1.- Upon receipt of the products, the Buyer shall perform a visual inspection in compliance with instructions provided in point 7 of UNI EN ISO 10545-2 standards.

G.2.- The products must be installed and fitted strictly respecting the recommendations related to the activities to be performed before and during the laying of the product specified in document 1) Laying, use, cleaning and maintenance manual, published on the Seller's website, and on the product packaging and/or inside the packaging. Faults caused by an incorrect installation and by missing/incorrect maintenance (different from instructions provided in document 1) Laying, use, cleaning and maintenance manual), by an unsuitable use and/or by normal wear over time shall not be considered product faults.

G.3.- With the exception of the limits of acceptability foreseen by the international EN 14411 (ISO 13006) standard, the parties acknowledge as identifiable faults those product defects that are immediately visible upon receipt thereof and that make the material unsuitable for use or that significantly reduce its value. This category includes faults as defined in the document 1) Laying, use, cleaning and maintenance manual, published on the Seller's website. Identifiable faults include, by way of a non-limiting example, superficial defects, decoration defects, defects concerning polishing, dimensions, surface flatness, straightness of sides/rectangularity and thickness, cracks, chippings or rough edges, non-compliant shades, mixed shades and products that feature problems deriving from the cutting process and/or from chips.

G.4.- If the Buyer finds an identifiable fault, it must be reported in writing to the Seller, within 8 (eight) days from receipt of the products; failure to send the claim shall result in the forfeiture and loss of such right. The Buyer shall keep the entire lot of material readily available for the Seller. The claim shall include the invoice details and an accurate description of the claimed fault together with photographs, where possible. In the event that the claim proves to be unfounded, the Buyer shall refund the Seller any costs incurred for an inspection (expert's reports, travel, etc.).

G.5.- Hidden faults shall be notified to the Supplier in writing, by recorded delivery letter with advice of receipt, within 8 days from the date such fault is found, under penalty of forfeiture.

G.6.- The Buyer's right to make a claim for faults under warranty is valid for 12 (twelve) months from the delivery of the products.

H.- WARRANTY FOR FAULTS

H.1. The Seller's warranty is limited to first grade products and not second or third grade products or lots on offer with special prices or discounts, which must be duly specified with a note in the order confirmation.

H.2. The Seller does not guarantee the suitability of the products for particular uses, and only guarantees the technical specifications published on the website in the document 2) Technical data sheets. The indication for use is merely indicative, even when written in the Seller's catalogues and manuals. On the basis of the characteristics described in the document 2) Technical data sheets, the designer always has the task of assessing the suitability of the product for the specific use conditions, taking into account the stress and variables to which the product will be subjected, which may alter its characteristics; for example, the traffic intensity, quality of traffic (foot traffic with the presence of sand, debris...), adverse weather conditions and any other unpredictable factor to which the material may be exposed.

H.3.- In the event that identifiable product faults are ascertained, as defined in sub section G no. 3, the Seller shall replace the faulty product with another one with equal or superior characteristics; should this not be possible, the Seller shall apply a significant price reduction. Alternatively, following the return of the faulty products, the Buyer shall have the right to a refund of the price paid plus the transport cost, with the exclusion of compensation for any other direct and/or indirect damage.

H.4. The Seller's warranty shall not be valid if the products that have identifiable faults (totally or in part) have been used and/or in any case transformed, as this entails that the Buyer (or its customer) expressed the intention to accept them in the condition in which they were found.

H.5.- In the event that hidden product faults are ascertained, the Seller's warranty is limited to the replacement with other products of equal or superior characteristics; should this not be possible the Seller shall refund the price paid plus the transport cost. In any case, the Seller's warranty for any direct and/or indirect damage caused by the faulty product, shall be limited to an amount that shall not be greater than double the selling price applied by the Seller, only in relation to the faulty part of the supply.

H.6.- In the event that the Buyer resells the product to subjects protected by the consumer code (law decree no. 206/2005), the former shall be responsible for the conditions applied, if different from those stated herein, and shall ensure that the consumer's rights are exercised, in relation to the remedies and terms established by the said code. If there are the grounds for the Buyer to exercise the right of recourse and/or make a claim against the Seller/manufacturer, the said action shall take into account or go beyond the exemptions and limits established in sub sections G no. 1 and H no. 5.

I. SOLVE ET REPETE (pay and then claim) AND TERMINATION CLAUSES

I.1.- Pursuant to article 1462 of the Italian Civil Code, on no account may the Buyer suspend or delay payment of collected material, including in the event of alleged defects or faults in the material; this does not affect the right to claim back any payments made unduly (solve et repete).

I.2.- If the Buyer's financial situation changes or in the event of non-payment (even partial) of products already supplied, the Seller reserves the right to suspend the execution of the supplies underway and/or to terminate the contracts in force and the Buyer shall not have the right to claim direct and/or indirect compensation of any type.

L.- RETENTION OF OWNERSHIP

L.1.- The products supplied shall remain exclusive property of the Seller until the Buyer has paid the full amount.

L.2.- During the aforementioned period, the Buyer shall undertake the obligations and responsibilities as bailee (also referred to as custodian) and shall not transfer the said products, grant their use, let them be seized or distrained without declaring that the property is of the Seller, and the Buyer shall immediately inform the Seller by recorded delivery letter with advice of receipt.

M.- FORCE MAJEURE

M.1.- Each party may suspend the fulfilment of its contractual obligations, when the said fulfilment is impossible or objectively too costly due to an unforeseeable impediment independent from the parties, such as for example: strike, boycott, lockout, fire, war (declared or not), civil war, riots and revolutions, requisitions, embargo, power blackouts, extraordinary breakage of machinery, delays in the delivery of components or raw materials.

M.2.- The party that wishes to apply this clause shall immediately notify the onset and end of the circumstances of force majeure to the other party in writing.

M.3.- If the suspension due to force majeure lasts longer than 60 (sixty) days, each party shall have the right to terminate this contract, with a notice of 10 (ten) days to be notified to the counterparty in writing.

N.- CONFIDENTIALITY

N.1.- The Buyer undertakes to maintain confidentiality as regards all information of a technical (such as, by way of a non-limiting example, drawings, tables, documentation, formulas and correspondence) and commercial nature (including contractual conditions, purchase prices, payment conditions,...) gained during the performance of this contract.

N.2.- The confidentiality obligation shall be undertaken for the entire duration of this contract and for the period following its execution.

N.3.- In case of failure to uphold the confidentiality obligation, the non-fulfilling party shall pay the other party compensation for all damages that may derive therefrom.

O.- SELLER'S TRADEMARKS AND DISTINCTIVE SIGNS

O.1.- The use of trademarks, ornamental designs and creative works in general, in whatever form and manner of expression (such as, by way of a non-limiting example: images, photos, drawings, videos, shapes, structures, etc.) constituting the Seller's intellectual property, through any means (such as, by way of a non-limiting example: press, video, radio, internet, social media, instant messaging platforms or VoIP, etc.) is strictly forbidden. Any exception to the said prohibition, even only partial, must be authorised in writing, each time, by the Seller's general management.

P.- CONTRACT LANGUAGE, APPLICABLE LAW, JURISDICTION AND AUTHORITY

P.1.- The present CONTRACT is drafted in Italian, and in case of disputes the said version shall prevail over any translations in other languages.

P.2.- Any dispute concerning the supply of products shall be subject to Italian law and jurisdiction and the Court of Modena, the town in which the Seller has its registered office, shall have sole local jurisdiction.

CONDITIONS GÉNÉRALES DE VENTE du 1er Janvier 2021

A.- MODALITÉS DE CONCLUSION DU CONTRAT

A.1.- Les présentes Conditions Générales de Vente régissent tout contrat de Vente entre le Vendeur et l'Acheteur et toute modification ou dérogation de ces dernières doit être convenue par écrit.

A.2.- D'éventuelles offres, accréditations et / ou ristournes accordées par des agents ou par d'autres intermédiaires, ne seront réputées valables que si elles sont confirmées par écrit par le Vendeur.

A.3.- L'Acheteur envoie au Vendeur, directement ou par l'intermédiaire d'agents, des Commandes écrites qui doivent indiquer les codes des Produits demandés, les quantités, leur prix et leur destination. La commande envoyée par l'Acheteur est irrévocable.

A.4.- La Vente doit être réputée conclue au moment où : (i) l'Acheteur reçoit de la part du Vendeur une Confirmation écrite par e-mail, par télécopie ou par d'autres moyens télématiques, conforme aux conditions de la Commande ; ou (ii) en cas de Confirmation envoyée par le Vendeur contenant des conditions différant de la Commande envoyée par l'Acheteur lorsque celui-ci l'accepte par écrit ou quoi qu'il en soit s'il ne la conteste pas dans un délai de 7 (sept) jours à compter de la réception ; ou (iii) en l'absence d'une confirmation écrite de la part du Vendeur, au moment où les Produits seront livrés et chargés par l'Acheteur.

A.5.- L'Acheteur partage l'exigence de limiter les ventes de produits Caesar au territoire national. Le Vendeur considère cette règle comme un élément indispensable lui permettant de coordonner sa politique commerciale et de rationaliser le réseau de distribution, avec des offres davantage orientées vers les exigences des différents Pays. De même, l'Acheteur reconnaît que cette exigence constitue également une mesure de protection de ses propres intérêts. L'Acheteur s'engage donc à commercialiser les produits fournis par Ceramiche Caesar SpA exclusivement dans son Pays de résidence, en s'abstenant de promouvoir les ventes actives également sollicitées en ligne auprès de clients situés sur le territoire d'un État différent du sien.

Pour les opérations triangulaires, la présente obligation s'applique au pays dans lequel l'acheteur opère effectivement. L'Acheteur pourra revendre le produit hors de son territoire avec l'autorisation écrite du Vendeur, ou si la revente concerne des produits qui ne sont pas de premier choix ou des produits hors production.

B.- PRIX

B.1.- Sauf accord contraire, les prix de vente convenus au fur et à mesure sont réputés nets, pour les paiements en espèces et les livraisons Franco l'établissement du Vendeur indiqué sur la Confirmation de Commande.

C.- CARACTÉRISTIQUES DES PRODUITS

C.1.- L'Acheteur déclare avoir lu et s'en tenir au contenu de la documentation suivante publiée sur le site Internet de la société: 1) Manuel de Pose, d'Utilisation, de Nettoyage et d'Entretien et 2) Fiches techniques.

C.2. Vu la variabilité intrinsèque du produit en céramique, les caractéristiques des échantillons et / ou des modèles envoyés précédemment par le Vendeur à l'Acheteur sont indicatifs et non contraignants.

C.3. Sauf en cas de demandes spécifiques à convenir avant la Confirmation de Commande, le Vendeur ne garantit pas la commande d'un article soit intégralement constituée par un même lot de production.

D.- DÉLAIS DE LIVRAISON

D.1.- Les délais de livraison s'entendent fournis à titre indicatif et leur prorogation ne donne en aucun cas le droit à l'Acheteur de demander des indemnités, excluant dès à présent toute exception.

D.2.- Si l'Acheteur ne retire pas le matériel, au bout d'un délai de 10 (dix) jours à compter de la date de l'annonce indiquant que la marchandise est prête, le Vendeur se réserve la faculté de fixer à sa discrétion un nouveau délai de livraison.

E.- LIVRAISON ET EXPÉDITION

E.1.- L'éventuelle variation de la destination des Produits, différente de celle convenue dans la Confirmation de Commande, doit être communiquée par l'Acheteur par écrit au plus tard le second jour qui précède le jour du retrait au siège du Vendeur. Le Vendeur se réserve la faculté de ne pas accepter la variation de la destination des Produits. Au cas où la destination effective du Produit serait différente de celle déclarée par l'Acheteur, le Vendeur se réserve la faculté de suspendre l'exécution des fournitures en cours et / ou de résilier le contrat sans que l'Acheteur puisse revendiquer des indemnités directes et / ou indirectes d'aucune sorte.

E.2.- Sauf accord contraire, la fourniture de la marchandise est livrée Départ Usine (EXW aux termes des Incoterms 2010) même si l'on a convenu que l'expédition ou une partie de cette dernière sera suivie par le Vendeur sur mandat de l'Acheteur. En tout état de cause, les risques passent à l'Acheteur au plus tard au moment de la livraison au premier transporteur.

E.3.- Sans préjudice du désintérêt du Vendeur par rapport au contrat de transport, celui-ci ne pourra être indiqué comme le "shipper" dans le connaissance. La communication du poids brut du container à l'expéditeur, ne constitue pas une prise de responsabilité de la part du Vendeur aux fins de la Convention SOLAS (Safety Of Life At Sea). En aucun cas cette communication ne pourra être considérée comme le VGM (Verified Gross Mass).

E.4.- L'Acheteur s'engage à ce que le véhicule envoyé aux entrepôts du Vendeur soit compatible avec la nature des Produits à charger. Si le véhicule qui se présente comporte des difficultés significatives pour les opérations de chargement, le Vendeur se réserve la faculté de débourser une pénalité de l'ordre de 4 % de la valeur des produits pour couvrir les coûts logistiques supplémentaires. Si le véhicule convenu n'est absolument pas compatible, le Vendeur se réserve la faculté de refuser les opérations de chargement sans que l'Acheteur ne puisse rien lui demander à titre de remboursement de toute dépense directe et / ou indirecte éventuelle.

E.5.- Il appartient à l'Acheteur de charger le transporteur de contrôler les produits avant le chargement ; d'éventuelles observations concernant l'intégrité des emballages et la correspondance des quantités chargées avec celles indiquées sur le document de transport doivent être soulevées par le transporteur au moment du chargement. Ces observations doivent être indiquées sur toutes les copies des documents de transport ; dans le cas contraire, les produits chargés sont réputés intacts et complets. Il s'ensuit que le Vendeur décline toute responsabilité en cas d'absence ou de détérioration des produits non signalée par le transporteur.

E.6.- L'Acheteur a également la responsabilité de charger le transporteur de vérifier les modalités et la stabilité du chargement sur le véhicule afin d'éviter les bris durant le transport et le respect de toutes les dispositions de sécurité concernant la circulation sur route.

F.- PAIEMENTS

F.1.- Toute obligation de paiement doit être accomplie au siège légal du Vendeur. Les éventuels paiements remis à des agents, à des représentants ou à des auxiliaires de commerce ne seront réputés effectués qu'au moment où le Vendeur percevra les sommes correspondantes.

F.2.- Il est interdit à l'Acheteur d'effectuer des paiements depuis un pays différent de son pays de résidence et ne garantissant pas un échange d'informations correct avec l'Italie. En cas de violation de cette interdiction, le Vendeur a la faculté de résilier le contrat pour juste cause sans que l'Acheteur ne puisse revendiquer le droit d'obtenir une quelconque réparation pour l'éventuel préjudice subi.

F.3.- Les éventuels frais de timbre et d'encaissement d'effets et de traites sont à la charge de l'Acheteur. En cas de défaillance, même partielle, des intérêts de retard commencent à courir en faveur du Vendeur, à compter du jour fixé pour le paiement, dans la mesure prévue par le Décret Législatif italien n° 231 du 09/10/2002.

F.4.- Sauf accord écrit contraire, l'Acheteur s'engage à ne compenser aucune créance échue.

G.- RÉCLAMATIONS

G.1.- À la réception des Produits, l'Acheteur devra soumettre ces derniers à un contrôle minutieux moyennant un examen visuel effectué conformément aux indications du point 7 des normes UNI EN ISO 10545-2.

G.2.- L'installation et la pose des Produits doivent être effectuées en suivant scrupuleusement les recommandations inhérentes aux activités exercées avant et durant la pose indiquées sur le document 1) Manuel de Pose, d'Utilisation, de Nettoyage et d'Entretien, publié sur le site Internet du Vendeur ainsi qu'à l'extérieur et/ou à l'intérieur de l'emballage du produit. Les défauts dus à une installation erronée et à un entretien absent / erroné (ne respectant pas les indications fournies dans le 1) Manuel de Pose, d'Utilisation, de Nettoyage et d'Entretien), par un usage prévu inapproprié et / ou par l'usure normale due au temps ne sont pas considérés comme des vices du Produit.

G.3.- Sous réserve des limites d'acceptabilité prévues par la norme internationale EN 14411 (ISO 13006), les Parties reconnaissent comme des Vices Évidents les défauts des Produits existant dès la réception de sorte que le matériel devienne inutilisable ou qu'il perde une grande partie de sa valeur. Cette catégorie comprend les défauts définis dans le document 1) Manuel de Pose, d'Utilisation, de Nettoyage et d'Entretien publié sur le site Internet du Vendeur. À titre d'exemple non contraignant, on reconnaît comme des Vices Évidents les défauts de surface, de décoration, de polissage, de calibre, de planéité, d'orthogonalité–rectitude, d'épaisseur, les fissures, les ébréchés, les hors nuance, les nuances mélangées et les Produits qui présentent des problèmes de coupe - voile.

G.4.- Si l'Acheteur relève des Vices Évidents, il devra présenter une réclamation écrite au Vendeur, sous peine de déchéance, dans un délai de 8 (huit) jours à compter de la réception et tenir le lot complet de matériel à la disposition de ce dernier. La réclamation devra indiquer les données de facturation et une description précise du vice objet de la réclamation, accompagnée, si possible, de photographies. Si la réclamation devait s'avérer sans fondement, l'Acheteur est disposé à rembourser au Vendeur les dépenses encourues pour l'éventuelle visite des lieux (expertises, déplacements, etc.).

G.5.- Les Vices Cachés devront être notifiés au Vendeur par lettre recommandée avec avis de réception, sous peine d'annulation de la garantie, dans un délai de 8 (huit) jours à compter de la date de la découverte du défaut.

G.6.- L'action de l'Acheteur ayant pour but de faire valoir la garantie en cas de vices se prescrit dans un délai de 12 (douze) mois à compter de la livraison des Produits.

H.- GARANTIE COUVRANT LES VICES

H.1. La garantie du Vendeur est réputée limitée aux seuls Produits de premier choix et non aux Produits de second ou de troisième choix ou à des lots d'occasion auquel on applique des prix ou des remises particuliers lorsqu'ils sont dûment signalés dans les notes de la Confirmation de Commande.

H.2. Le Vendeur ne garantit pas l'adéquation des Produits à des usages particuliers, mais uniquement les caractéristiques techniques publiées sur le site Internet dans le document 2) Fiches techniques. L'usage indiqué, également lorsqu'il est présenté par le Vendeur dans des catalogues et des manuels, est purement indicatif. Sur la base des caractéristiques techniques indiquées dans les 2) Fiches Techniques, le concepteur a toujours le devoir d'évaluer l'adéquation du Produit aux conditions spécifiques d'utilisation en fonction des contraintes et des variables pouvant se vérifier dans le lieu de destination et susceptibles d'en altérer les caractéristiques, par exemple, l'intensité et la qualité de la circulation (piétinement en présence de sable, de détritus...), ainsi que les éventuelles conditions climatiques défavorables et toute autre incidence à laquelle peut être exposé le matériel.

H.3.- Si l'on a constaté que le Produit présente les Vices Évidents définis à la lettre G n°3, le Vendeur remplacera le Produit défectueux par un autre produit ayant des caractéristiques analogues ou supérieures ou, lorsque cela est impossible, à une réduction cohérente du prix. En alternative, l'Acheteur aura droit, après la restitution des Produits défectueux, au remboursement du prix payé, majoré du prix du transport, à l'exclusion du remboursement de tout autre préjudice direct et / ou indirect.

H.4. La garantie du Vendeur doit être réputée exclue au cas où le Produit présentant des Vices Évidents (entièrement ou partiellement) aurait été utilisé et / ou du moins transformé ; dans ce cas, on considèrera que l'Acheteur (ou son client) a exprimé la volonté de les accepter en l'état.

H.5 Si l'on a constaté que le Produit présente des Vices Cachés, la garantie du Vendeur se limite au remplacement du matériel par du matériel ayant des caractéristiques analogues ou supérieures et, lorsque cela est impossible, au remboursement du prix payé majoré des frais de transport. En tout état de cause, la garantie du Vendeur couvrant tout dommage direct et / ou indirect causé par le produit défectueux, se limitera à une somme qui ne pourra pas dépasser le double du prix de vente appliqué par le Vendeur dans le cadre de la seule partie de la fourniture défectueuse.

H.6.- Si l'Acheteur revend le Produit à des clients protégés par le code de la consommation (Décret–loi italien n° 206/2005) il sera responsable des conditions appliquées si celles-ci diffèrent des conditions indiquées ici et il devra s'assurer que les droits du consommateur sont exercés dans le respect des remèdes et des délais fixés par ce code. Si les conditions sont réunies, le droit de retrait et / ou de recours revenant à l'Acheteur à l'encontre du Vendeur / fabricant ne pourra dépasser ni les exonérations ni les limites établies de la lettre G n°1 à la lettre H n°5.

I. CLAUSES SOLVE ET REPETE ET CLAUSES RÉSOLUTOIRES

I.1.- Aux termes de l'art. 1462 du Code Civil italien, en aucun cas, y compris les prétendus vices ou défauts du matériel, l'Acheteur ne pourra suspendre ou retarder le paiement du matériel retiré, sans préjudice naturellement de la faculté d'exiger lorsqu'il est en mesure de démontrer avoir indûment payé.

I.1.- En cas de variation des conditions patrimoniales de l'Acheteur ou de non-paiement même partiel de produits déjà fournis, le Vendeur se réserve la faculté de suspendre l'exécution des fournitures en cours et / ou de résilier les contrats sans que l'Acheteur ne puisse revendiquer des indemnisations directes et / ou indirectes d'aucune sorte.

L.- PACTE DE RÉSERVE DE PROPRIÉTÉ

L.1.- Tant que l'Acheteur n'aura pas intégralement payé le prix, les Produits objet de la fourniture resteront la propriété du Vendeur.

L.2.- Au cours de la susdite période, l'Acheteur assumera les obligations et les responsabilités de gardien, et il ne pourra ni aliéner, ni confier, ni permettre la saisie desdits Produits sans déclarer la propriété du Vendeur et informer immédiatement ce dernier par lettre recommandée avec avis de réception.

M.- FORCE MAJEURE

M.1.- Chacune des parties pourra suspendre l'accomplissement de ses obligations contractuelles lorsque cette exécution est rendue impossible ou objectivement trop onéreuse par un empêchement imprévisible indépendant de sa volonté comme : les grèves, les boycottages, les lock-outs, les incendies, les guerres (déclarées ou non), les guerres civiles, les révoltes et les révolutions, les réquisitions, les embargos, les coupures de courant, les ruptures exceptionnelles de machines, les retards de livraison de composants ou de matières premières.

M.2.- La partie qui souhaite user de la présente clause devra communiquer immédiatement par écrit à l'autre partie la survenue et la cessation des circonstances de force majeure.

M.3.- Si la suspension due à une force majeure dure plus de 60 (soixante) jours, chacune des parties aura le droit de résilier le présent contrat, avec un préavis de 10 (dix) jours, en le communiquant par écrit à la partie adverse.

N.- OBLIGATIONS DE CONFIDENTIALITÉ

N.1.- L'Acheteur est tenu d'observer le secret le plus absolu concernant toutes les informations de caractère technique (comme, par exemple, les dessins, les notices, les documentations, les fiches et la correspondance) et de caractère commercial (y compris les conditions contractuelles, les prix d'achat, les conditions de paiement, etc.) dont il aurait eu connaissance durant l'exécution du présent Contrat.

N.2.- L'obligation de confidentialité est assumée pendant toute la durée du Contrat, ainsi que pour la période successive à son exécution.

N.3.- Dans tous cas de non–observation de l'obligation de confidentialité, la partie défaillante est tenue de réparer à l'autre partie tous les éventuels préjudices.

O.- MARQUES ET SIGNES DISTINCTIFS DU VENDEUR

O.1.- L'utilisation des marques, des modèles ornementaux et des œuvres de l'esprit en général, sous quelque forme ou suivant quelque modalité d'expression que ce soit (à titre d'exemple, non contraignant : les images, les photos, les dessins, les vidéos, les figures, les structures, etc.) constituant la propriété intellectuelle du Vendeur, à travers tout moyen (à titre d'exemple non contraignant : l'impression, la vidéo, la radio, Internet, les médias sociaux, les plates-formes de messagerie instantanée ou VoIP, etc.) est formellement interdite. Toute dérogation à cette interdiction, même partielle, devra être autorisée par écrit, cas par cas, par la Direction générale du Vendeur.

P.- LANGUE DU CONTRAT, LOI APPLICABLE, JURIDICTION ET COMPÉTENCE

P.1.- Le Contrat et les présentes conditions sont rédigés en langue italienne qui prévaut en cas de divergence avec la traduction dans d'autres langues.

P.2.- La définition de toute controverse relative aux fournitures est régie par la loi et la juridiction de l'État italien et les parties reconnaissent la compétence territoriale exclusive du Tribunal de Modène dans la circonscription duquel se trouve le siège légal du Vendeur.

ALLGEMEINE VERKAUFSBEDINGUNGEN vom 1. Januar 2021

A.- MODALITÄT DES VERTRAGSABSCHLUSSES

A.1.- Die vorliegenden Allgemeinen Verkaufsbedingungen regeln alle Verträge zwischen dem Verkäufer und dem Käufer und alle Änderungen oder Abweichungen davon müssen schriftlich vereinbart werden.

A.2.- Eventuelle Angebote sowie mit Handelsvertretern oder sonstigen Vermittlern vereinbarten Gutschriften sind nicht verbindlich, es sei denn, sie werden vom Verkäufer schriftlich bestätigt.

A.3.- Der Käufer sendet dem Verkäufer direkt oder über Handelsvertreter schriftliche Bestellungen zu, die die Angabe der Artikelnummern der gewünschten Produkte, der Mengen, ihres Preises und der Bestimmung enthalten müssen. Die vom Käufer gesendete Bestellung ist unwiderruflich.

A.4.- Der Verkauf gilt zu dem Zeitpunkt als abgeschlossen, an dem: (i) der Käufer vom Verkäufer eine schriftliche Bestätigung per E-Mail, Fax oder auf sonstigem Weg erhält, die den Fristen und Bedingungen der Bestellung entspricht; oder (ii) falls die vom Verkäufer gesendete Bestätigung, Bedingungen enthält, die von der vom Käufer erhaltenen Bestellung abweichen, wenn dieser diese akzeptiert oder nicht innerhalb von 7 (sieben) Tagen ab ihrem Empfang beanstandet; oder (iii) falls keine schriftliche Bestätigung durch den Verkäufer erfolgt, zu dem Zeitpunkt, an dem die Produkte geliefert und vom Käufer übernommen werden.

A.5.- Der Käufer teilt die Notwendigkeit, das nationale Gebiet für die Verkäufe der Produkt von Caesar zu unterteilen. Der Verkäufer hält diese Regel für ein unverzichtbares Element, um es ihm zu gestatten, seine kommerzielle Politik zu koordinieren und sein Vertriebsnetz mit Angeboten für die Erfordernisse der einzelnen Länder zu rationalisieren. Außerdem erkennt der Käufer an, dass diese Notwendigkeit auch zum Schutz der eigenen Interessen dient. Der Käufer verpflichtet sich daher, die von Ceramiche Caesar SpA gelieferten Produkte ausschließlich in dem Land zu vertreiben, in dem er seinen Firmensitz hat, und den aktiven Verkauf – auch online – an Kunden mit Sitz in einem anderen Staat zu unterlassen. Für Dreiecksgeschäfte wird die vorliegende Pflicht auf das Land angewendet, in dem der Käufer effektiv tätig ist. Der Käufer kann das Produkt außerhalb seines eigenen Gebiets verkaufen, falls er die schriftliche Genehmigung des Verkäufers einholt, oder falls der Verkauf nicht Produkte erster Wahl oder Produkte außerhalb der Produktion betrifft.

B.- PREISE

B.1.- Vorbehaltlich abweichender schriftlicher Vereinbarungen gelten die von Mal zu Mal vereinbarten Verkaufspreise als Nettobarpreise bar mit Lieferung frei ab dem in der Auftragsbestätigung angegebenen Werk des Verkäufers.

C.- EIGENSCHAFTEN DER PRODUKTE

C.1.- Der Käufer erklärt, die folgende auf der Web-Site des Unternehmen veröffentlichte Dokumentation zur Kenntnis genommen zu haben und sich an deren Inhalt zu halten: 1) Handbuch zur Verlegung, Benutzung, Reinigung und Pflege, und 2) Technische Datenblätter.

C.2. Aufgrund der intrinsischen Variabilität des Keramikprodukts sind die Eigenschaften der vorausgehend vom Verkäufer an den Käufer gesendeten Warenmuster und/oder Modelle hinweisend und unverbindlich.

C.3. Vorbehaltlich spezifischer Vereinbarungen vor der Auftragsbestätigung garantiert der Verkäufer nicht, dass die Lieferung des einzelnen Artikels vollständig mit dem gleichen Produktionslos ausgeführt wird.

D.- LIEFERFRISTEN

D.1.- Die Lieferfristen sind unverbindlich und Verzögerungen führen für den Käufer in keinem Fall zum Anspruch auf Schadensvergütung.

D.2.- Falls der Käufer das Material nicht innerhalb von 10 (zehn) Tagen ab dem Datum der Bereitstellung der Waren abholt, behält sich der Verkäufer das Recht vor, eine neue Lieferfrist festzusetzen.

E.- RÜCKLIEFERUNG UND VERSAND

E.1.- Die eventuelle Änderung des Bestimmungsortes der Produkte, die sich von der in der Auftragsbestätigung vereinbarten unterscheidet, muss vom Käufer schriftlich innerhalb des zweiten Tags vor dem für die Abholung am Sitz des Verkäufers vorgesehenen mitgeteilt werden. Der Verkäufer behält sich das Recht vor, die Änderung der Bestimmung der Produkte nicht zu akzeptieren. Falls sich herausstellt, dass die effektive Bestimmung des Produkts von der vom Käufer angegebenen verschieden ist, behält sich der Verkäufer das Recht vor, die laufenden Lieferungen nicht auszuführen und/oder die laufenden Verträge aufzulösen, ohne dass der Käufer jeglichen Anspruch auf Entschädigung geltend machen kann.

E.2.- Vorbehaltlich abweichender Vereinbarungen erfolgt die Lieferung der Ware frei ab Werk (EXW gemäß den Incoterms 2010), und dies auch, falls vereinbart wird, dass der Versand oder ein Teil desselben im Auftrag des Käufers durch den Verkäufer erfolgt. In jedem Fall gehen die Risiken spätestens mit der Übergabe an das erste Transportunternehmen an den Käufer über.

E.3.- Unter Beibehaltung der Nichtbeteiligung des Verkäufers am Transportvertrag kann der Verkäufer in der Police der Ladung als „Shipper“ angegeben werden. Die Mitteilung des Bruttogewichts des Containers an den Transportunternehmer stellt keine Übernahme der Verantwortung des Verkäufers hinsichtlich der SOLAS-Konvention dar (Safety Of Life At Sea). In keinem Fall kann diese Mitteilung als VGM (Verified Gross Mass) verstanden werden.

E.4.- Der Käufer verpflichtet sich sicherzustellen, dass das zu den Lagern des Verkäufers gesendete Fahrzeug unter Berücksichtigung der Natur der Produkte für das Laden geeignet ist. Falls das zum Laden gesendete Fahrzeug größere Probleme beim Beladen bereitet, behält der Verkäufer sich das Recht vor, zur Abdeckung der höheren Logistikkosten eine Vertragsstrafe in Höhe von 4 % des Werts der Produkte zu erheben. Falls das Fahrzeug vollkommen ungeeignet ist, behält sich der Verkäufer das Recht vor, das Verladen zu verweigern, ohne dass der Käufer einen Anspruch auf Vergütung der Schäden geltend machen kann, die direkt und/oder indirekt daraus entstehen können.

E.5.- Es ist Aufgabe des Käufers, das Transportunternehmen zu beauftragen und die Produkte vor dem Laden zu kontrollieren; eventuelle Anmerkungen zur Unversehrtheit der Verpackungen und der Übereinstimmung der geladenen Menge mit der in den Transportpapieren angegebenen müssen vom Transportunternehmen zum Zeitpunkt des Ladens vorgenommen werden. Diese Anmerkungen müssen auf alle Exemplaren der Transportpapiere vermerkt werden, anderenfalls gelten die geladenen Produkte als unbeschädigt und vollständig. Daraus folgt, dass der Verkäufer keinerlei Haftung für Fehlmengen oder Beschädigungen der Produkte übernimmt, die vom Transportunternehmen nicht gemeldet werden.

E.6.- Es ist ebenfalls Aufgabe des Käufers, das Transportunternehmen zu beauftragen und die Modalität und die Stabilität des Ladens auf das Fahrzeug zu überprüfen, damit es während des Transports nicht zu Brüchen kommt, sowie die Einhaltung der Sicherheitsbestimmungen der Straßenverkehrsordnung zu gewährleisten.

F.- ZAHLUNGEN

F.1.- Alle Zahlungsverpflichtung müssen am Firmensitz des Verkäufers erfüllt werden. Eventuelle Zahlungen an Handelsvertreter oder Außendienstmitarbeiter gelten als nicht geleistet, bis sie beim Verkäufer eingehen.

F.2.- Es ist dem Käufer untersagt, die Zahlungen aus Ländern vorzunehmen, die vom Land seines Firmensitzes verschieden sind, falls diese Länder keinen angemessenen Informationsaustausch mit Italien gewährleisten. Im Fall der Verletzung dieses Verbots hat der Verkäufer das Recht, den Vertrag aus gutem Grund aufzulösen, ohne dass der Käufer eine Vergütung des entstandenen Schadens geltend machen kann.

F.3.- Eventuelle Kosten und Gebühren für die Einziehung von Effekten und Wechseln gehen zu Lasten des Käufers. Im Fall der Nichteinhaltung des für die Zahlung festgesetzten Tags - auch nur partiell - fallen Säumniszinsen zu Gunsten des Verkäufers an, in der vom ital. Gesetzerlass vom 9. Oktober 2002, Nr. 231 vorgesehenen Höhe.

F.4.- Vorbehaltlich abweichender schriftlicher Vereinbarungen verpflichtet sich der Käufer, keine Guthaben gegenüber dem Verkäufer zu verrechnen.

G.- BEANSTANDUNGEN

G.1.- Beim Empfang der Produkte muss der Käufer sie einer sorgfältigen Sichtkontrolle gemäß den Angaben von Punkt 7 der Normen UNI EN ISO 10545-2 unterziehen.

G.2.- Die Installation und die Verlegung der Produkte müssen unter Einhaltung der Empfehlungen zu den Arbeiten ausgeführt werden, die vor und während der Verlegung ausgeführt werden müssen, wie angegeben im Dokument 1) Handbuch zur Verlegung, Verwendung, Reinigung und Pflege, veröffentlicht auf der Web-Site des Verkäufers und angegeben auf der Verpackung des Produkts und/oder im Inneren derselben. Schäden, die durch eine falsche Installation, Verlegung und durch eine unterlassene/falsche Pflege (abweichend von den Angaben in 1) Handbuch zur Verlegung, Reinigung und Wartung), durch eine ungeeignete Gebrauchsbestimmung oder durch normale Abnutzung verursacht werden, werden nicht als Mängel des Produkts anerkannt.

G.3.- Vorbehaltlich der Grenzen der Akzeptabilität, die von der internationalen Norm EN 14411 (ISO 13006) vorgesehen sind, erkennen die Parteien Mängel der Produkte als offensichtliche Mängel an, die bereits bei ihrem Empfang festgestellt werden können, die das Material zur Verwendung ungeeignet machen oder die den Wert beträchtlich verringern. In diese Kategorie

fallen Mängel, wie im Dokument definiert 1) Handbuch zur Verlegung, Benutzung, Reinigung und Pflege, veröffentlicht auf der Web-Site des Verkäufers. Als nicht erschöpfende Beispiele werden Oberflächenmängel, fehlerhafte Grafik, Defekte polierte Oberfläche, Defekte des Kalibers, der Planarität, der Rechtwinkligkeit/Gradlinigkeit, der Stärke, Risse, abgeschlagene Kanten, Fehlfarbe, gemischte Brandfarbe sowie Produkte mit Kantsplitterung durch Rettifizierung als offensichtliche Mängel anerkannt.

G.4.- Falls der Käufer offensichtliche Mängel feststellt, muss er dies dem Verkäufer innerhalb von 8 (acht) Tagen ab dem Empfang schriftlich melden und die gesamte Charge des Materials für den Verkäufer zur Verfügung halten; anderenfalls verfällt der Rechtsanspruch. Bei der Beanstandung müssen die Daten der Rechnung sowie eine präzise Beschreibung des beanstandeten Mangels angegeben werden, falls möglich mit einer fotografischen Dokumentation. Falls die Beanstandung unberechtigt sein sollte, ist der Käufer gehalten, dem Verkäufer die für einen eventuellen Ortstermin aufgewendeten Kosten (Gutachten, Reisekosten, usw.) zu erstatten.

G.5.- Versteckte Mängel müssen dem Verkäufer innerhalb von 8 (acht) Tagen ab Feststellung des Mangels per Einschreiben mit Rückschein gemeldet werden: anderenfalls verfällt der Rechtsanspruch.

G.6.- Die Aktion des Käufers zur Inanspruchnahme der Mängelhaftung muss in jedem Fall innerhalb von 12 (zwölf) Monaten ab der Lieferung der Produkte erfolgen.

H.- MÄNGELHAFTUNG

H.1. Die Garantie des Verkäufers ist begrenzt auf Produkte erster Qualität und sie bezieht sich nicht auf Produkte zweiter oder dritter Qualität oder auf gelegentliche Partien mit besonderen Preisen oder Nachlässe, die in der Auftragsbestätigung angegeben werden.

H.2. Der Verkäufer garantiert nicht die Eignung der Produkte für besondere Verwendungen, sondern lediglich die technischen Eigenschaften, die auf der Web-Site in Dokument 2) Technische Datenblätter veröffentlicht sind. Die Angabe zur Verwendung ist als unverbindlich anzusehen, auch wenn vom Verkäufer in Katalogen und Handbüchern angegeben ist. Es ist stets Aufgabe des Planers, auf der Grundlage der in den 2) Technischen Datenblättern angegebenen Eigenschaften die Eignung des Produkts für spezifische Nutzungsbedingungen zu bewerten, unter Berücksichtigung der Belastungen sowie der Variablen, die am Ort der Bestimmung auftreten und die Eigenschaften verändern können, wie zum Beispiel die Intensität des Verkehrs, die Qualität des Verkehrs (Begehung bei Vorhandensein von Sand, Schmutz usw.), die eventuellen klimatischen Bedingungen sowie alle sonstigen Einflüsse, denen das Material ausgesetzt sein kann.

H.3.- Falls festgestellt wird, dass das Produkt offensichtliche Mängel aufweist, wie definiert in Punkt G, Nr. 3, nimmt der Verkäufer die Ersetzung des mangelhaften Produkts durch ein anderes mit gleichen oder höherwertigen Eigenschaften vor, oder er nimmt eine angemessene Reduzierung des Preises vor, falls dies nicht möglich ist. Alternativ hat der Käufer nach Rücklieferung der mangelhaften Produkte das Recht auf Rückerstattung des bezahlten Preises, zuzüglich der Transportkosten, mit Ausschließung der Vergütung aller direkten und/oder indirekten Schäden.

H.4. Die Garantie des Verkäufers wird ausgeschlossen, falls das mangelhafte Produkt (ganz oder teilweise) verwendet und/oder umgewandelt worden ist, da davon ausgegangen wird, dass der Käufer (oder sein Kunde) dadurch seinen Willen zum Ausdruck gebracht hat, es in dem Zustand zu akzeptieren, in dem es sich befindet.

H.5 Falls festgestellt wird, dass das Produkt versteckte Mängel aufweist, ist die Garantie des Verkäufers auf die Ersetzung des Materials durch anderes mit gleichen oder höherwertigeren Eigenschaften beschränkt oder - falls dies nicht möglich ist - auf die Rückerstattung des bezahlten Preises, zuzüglich der Transportkosten. In jedem Fall ist die Garantie des Verkäufers für alle direkten und/oder indirekten Schäden, die durch das mangelhafte Produkt entstehen, auf einen Betrag begrenzt, der das Doppelte des Verkaufspreises nicht übersteigen kann, den der Verkäufer auf den mangelhaften Teil der Lieferung angewendet hat.

H.6.- Falls der Käufer das Produkt an Kunden weiterverkauft, die vom Verbraucherschutzgesetz (ital. Gesetzerlass Nr. 206/2005) geschützt werden, ist er verantwortlich für die angewendeten Bedingungen, falls diese von den hier angegebenen abweichen, und er muss sicherstellen, dass die Rechte des Verbrauchers gemäß den Bestimmungen dieses Gesetzes ausgeübt werden können. Falls die Voraussetzungen gegeben sind, kann das Regressrecht des Käufers gegenüber dem Verkäufer/Hersteller nicht die Grenzen übersteigen, die von Punkt G, Nr. 1 bis Punkt H, Nr. 5 angegeben werden.

I. KLAUSEL SOLVE ET REPETE UND AUFLÖSUNGSKLAUSEL

I.1.- Gemäß den Bestimmungen von § 1462 des ital. Bürgerlichen Gesetzbuches kann der Käufer in keinem Fall - einschließlich von vermeintlichen Mängeln oder Defekten des Materials - die Zahlung des abgenommenen Materials aussetzen oder verzögern, natürlich vorbehaltlich des Rechts, ungerechtfertigt gezahlte Beträge zurückzufordern, und dies nur nach Erbringung des Nachweises der Rechtmäßigkeit der Forderung (Solve et Repete).

I.2.- Im Fall der Veränderung der Vermögensbedingungen des Käufers oder der auch nur partiellen Nichtbezahlung der bereits gelieferten Produkte kann der Verkäufer die laufenden Lieferungen aussetzen und/oder die laufenden Verträge auflösen, ohne dass der Käufer die Vergütung von direkten und/oder indirekten Schäden geltend machen kann.

L.- EIGENTUMSVORBEHALT

L.1.- Bis zur vollständigen Bezahlung des Preises durch den Käufer bleiben die Produkte, die den Gegenstand der Lieferung darstellen, Eigentum des Verkäufers.

L.2.- Während dieses Zeitraums übernimmt der Käufer die Pflichten und die Verantwortlichkeiten für die Aufbewahrung der gekauften Produkte und er kann sie nicht veräußern, zur Nutzung überlassen oder beschlagnahmen oder pfänden lassen, ohne das Eigentum des Verkäufers anzugeben und ohne diesen umgehend per Einschreiben mit Rückschein zu benachrichtigen.

M.- HÖHERE GEWALT

M.1.- Beide Parteien können die Ausführung der vertraglichen Pflichten aussetzen, wenn die Ausführung aus Gründen, die vom eigenen Willen unabhängig sind, unmöglich oder objektiv zu aufwendig wird, wie zum Beispiel: Streiks, Boykott, Aussperrung, Brand, Krieg (erklärt oder nicht), Bürgerkrieg, Aufstände und Revolutionen, Beschlagnahme, Embargo, Unterbrechungen der Energieversorgung, außerordentliche Defekte von Maschinen, Verspätung bei der Anlieferung von Komponenten und Rohstoffen.

M.2.- Die Partei, die beabsichtigt, die vorliegende Klausel in Anspruch zu nehmen, muss der anderen Partei schriftlich das Auftreten von Umständen der Höheren Gewalt mitteilen.

M.3.- Falls die Aussetzung aufgrund von Höherer Gewalt mehr als 60 (sechzig) Tage andauert, haben beiden Parteien das Recht, den vorliegenden Vertrag nach einer schriftlichen Vorankündigung von 10 (zehn) Tagen an die Gegenpartei aufzulösen.

N.- VERTRAULICHKEITSPFLICHT

N.1.- Der Käufer ist gehalten, über alle technischen Informationen (wie zum Beispiel Zeichnungen, Prospekte, Dokumentationen, Formeln und Schriftverkehr) und kommerziellen Informationen (einschließlich der Vertragsbedingungen, der Kaufpreise, der Zahlungsbedingungen usw.), in deren Kenntnis während der Ausführung des vorliegenden Vertrages kommt, absolute Vertraulichkeit einzuhalten.

N.2.- Die Vertraulichkeitspflicht wird für die Dauer des Vertrages sowie den Zeitraum nach seiner Ausführung übernommen.

N.3.- Im Fall der Nichteinhaltung der Vertraulichkeitspflicht ist die nicht einhaltende Partei gehalten, der anderen Partei alle daraus entstehenden Schäden zu vergüten.

O.- MARKEN UND KENNZEICHNUNGEN DES VERKÄUFERS

O.1.-Die Verwendung von Marken, Ziermotiven und geistigem Eigentum im Allgemeinen in jeder Form sowie jeder Ausdrucksform (als nicht erschöpfendes Beispiel: Bilder, Fotos, Zeichnungen, Filme, Abbildungen, Strukturen usw.), die intellektuelles Eigentum des Verkäufers sind, ist auf jede Weise (als nicht erschöpfendes Beispiel: Presse, Video, Radio, Internet, Social Media, Instant-Message-Plattform oder VoIP usw.) strengstens untersagt. Alle - auch nur partielle - Abweichungen von diesem Verbot müssen von Fall zu Fall schriftlich von der Generaldirektion des Verkäufers autorisiert werden.

P.- SPRACHE DES VERTRAGS, ANWENDBARES RECHT, RECHTSPRECHUNG UND GERICHTSSTAND

P.1.- Der Vertrag und die vorliegenden Bedingungen werden in italienischer Sprache verfasst, die im Fall der Abweichung der Übersetzung in andere Sprachen Vorrang hat.

P.2.- Die Regelung aller Rechtssachen hinsichtlich den Lieferungen unterliegt der Rechtsprechung des italienischen Staats und die territoriale Zuständigkeit liegt ausschließlich beim Bezirksgericht Modena, dem Ort des Firmensitzes des Verkäufers.

ОБЩИЕ УСЛОВИЯ ПРОДАЖИ от 1го Января 2021

A.- ПОРЯДОК ЗАКЛЮЧЕНИЯ ДОГОВОРА

A.1. - Настоящие Общие условия продажи регулируют любой договор продажи, заключенный между Продавцом и Покупателем; любое изменение или отступление от них должно быть согласовано в письменной форме.

A.2.- Возможные коммерческие предложения, зачисления и/или бонусы, предоставленные агентами или другими посредниками, не имеют силы, если они не были подтверждены в письменной форме Продавцом.

A.3.- Покупатель направляет Продавцу непосредственно или через агентов письменные заказы, в которых должны быть указаны коды запрошенной продукции, количества, цены и место назначения. Отправленный Покупателем заказ отмене не подлежит.

A.4.- Продажа считается завершенной в тот момент, когда: (i) Покупатель получает от Продавца по электронной почте, факсу или другим телематическим средствам связи письменное подтверждение, соответствующее срокам и условиям заказа; или (ii) в случае, если в отправленном Продавцом подтверждении указаны условия, отличающиеся от условий в заказе Покупателя, если Покупатель письменно принимает это подтверждение или не возражает на него в течение 7 (семи) дней после его получения; или (iii) при отсутствии письменного подтверждения Продавца, в тот момент, когда Продукция передается Покупателю и загружается им.

A.5.- Покупатель соглашается с необходимостью ограничить территорию продажи продукции Atlas Concorde государственными границами. Продавец считает это правило необходимым элементом, который позволит ему координировать свою коммерческую политику и оптимизировать дистрибутивную сеть посредством предложений, которые будут больше соответствовать потребностям отдельных стран. Аналогично этому, Покупатель соглашается, что эта необходимость представляет собой защиту также и его интересов. Таким образом, Покупатель обязуется реализовывать продукцию, поставленную компанией Ceramiche Atlas Concorde SpA, лишь только в его стране, воздерживаясь от продвижения активной продажи, также онлайновой, клиентам, находящимся на территории другой страны. В операциях триангуляции данное обязательство распространяется на страну, в которой ведется реальная оперативная деятельность Покупателя. Покупатель сможет перепродать продукцию за пределами своей территории в том случае, если он получит письменное разрешение Продавца, или же в случае перепродажи продукции не первого сорта или снятой с производства.

B.- ЦЕНЫ

B.1.- При отсутствии иных письменных договоренностей согласованные в каждом отдельном случае отпускные цены подразумеваются как цены нетто, за наличный расчет и на условиях поставки франко завод Продавца, указанный в подтверждении заказа.

C.- ХАРАКТЕРИСТИКИ ПРОДУКЦИИ

C.1.- Покупатель заявляет, что он ознакомился и придерживается содержания следующей документации, размещенной на корпоративном сайте в интернете: 1) Руководство по укладке, использованию, чистке и уходу и 2) Технические данные.

C.2. Учитывая свойственное непостоянство керамической продукции, характеристики образцов и/ моделей, ранее отправленных Продавцом Покупателю, должны считаться ориентировочными и не обязывающими.

C.3. При отсутствии специальных требований, которые должны быть оговорены до подтверждения заказа, Продавец не гарантирует, что заказ на отдельное изделие будет полностью состоять из одной и той же производственной партией.

D.- СРОКИ ПОСТАВКИ

D.1.- Сроки поставки должны считаться ориентировочными, а их отсрочка не дает Покупателю ни при каких обстоятельствах право требовать компенсацию.

D.2.- Если Покупатель не заберет материал по истечении 10 (десяти) дней с момента уведомления о готовности товара, Продавец может по собственному усмотрению назначить новый срок поставки.

E.- ДОСТАВКА И ОТГРУЗКА

E.1.- О возможном изменении места назначения Продукции, если оно отличается от места, согласованного в подтверждении заказа, необходимо сообщить Продавцу в письменной форме не позднее, чем за два дня до даты, предусмотренной для вывоза товара с завода Продавца. Продавец оставляет за собой право не принимать изменение места назначения Продукции. Если устанавливается, что фактическое место назначения Продукции отличалось от заявленного Покупателем, то Продавец оставляет за собой право на приостановку исполнения текущих поставок и/или на расторжение текущих договоров без права Покупателя на требование прямого или косвенного возмещения какого-либо типа.

E.2.- При отсутствии иных договоренностей поставка товара подразумевается на условиях франко-завод (EXW в соответствии с правилами Incoterms 2010), даже если было согласовано, что отгрузка или ее часть должна осуществляться Продавцом по поручению Покупателя. В любом случае риск переходит к Покупателю не позднее чем при передаче товара первому грузоперевозчику.

E.3.- Исходя из того, что Продавец не является стороной договора перевозки, в коносаменте не допускается указание Продавца как "грузоотправителя". Сообщение Продавцом грузоперевозчику веса брутто контейнера не является принятием на себя ответственности в соответствии с конвенцией СОЛАС (Safety Of Life At Sea). Это сообщение не может ни в коем случае толковаться как проверка массы грузных контейнеров VGM (Verified Gross Mass).

E.4.- Покупатель обязуется направить на склад Продавца транспортное средство, пригодное для погрузки Продукции данного типа. Если прибывшее транспортное средство значительно затрудняет выполнение погрузочных операций, то Продавец оставляет за собой право наложить пеню в размере 4% от стоимости продукции за возмещение более высоких логистических расходов. Если согласованное транспортное средство является совершенно неподходящим, Продавец оставляет за собой право отказать в выполнении погрузочных операций, при этом Покупатель не может требовать возмещения вытекающего из этого любого прямого и/или косвенного убытка.

E.5.- Покупатель обязан поручить грузоперевозчику проверку продукции перед ее погрузкой. Возможные замечания о целостности упаковки и о соответствии загруженных количеств тем, которые указаны в транспортной накладной, должны быть сделаны грузоперевозчиком в момент погрузки. Эти замечания необходимо указать во всех копиях транспортных накладных, в противном случае погруженная продукция считается неповрежденной и комплектной. Из этого следует, что Продавец не несет никакой ответственности за недостачи или повреждения продукции, не отмеченные грузоперевозчиком.

E.6.- Кроме того, Покупатель также обязан поручить грузоперевозчику проверку порядка погрузки и стабильности груза в транспортном средстве, чтобы во время перевозки не возникли повреждения, и чтобы были соблюдены все правила безопасности дорожного движения.

F.- ОПЛАТА

F 1.- Любые платежные обязательства должны выполняться по юридическому адресу Продавца.Оплата агентам, представителям или торговым помощникам считается несовершенной до тех пор, пока соответствующие суммы не поступят Продавцу.

F 2.- Покупателю запрещается выполнять свои обязательства путем оплаты из стран, не являющихся страной, резидентом которой он является, если эти страны не гарантируют адекватный обмен информацией с Италией. В случае нарушения этого запрета Продавец имеет право на расторжение договора с надлежащим правовым основанием, а у Покупателя не возникнет право на получение какого-либо возмещения за понесенный ущерб.

F 3.- Пошлины и расходы на инкассирование векселей и тратт несет Покупатель. В случае даже частичной задержки платежа по сравнению с назначенным днем оплаты в пользу Продавца будут начисляться проценты в размере, предусмотренном законодательным декретом от 09/10/2002 № 231.

F 4.- При отсутствии иных письменных договоренностей Покупатель обязуется не компенсировать никакой кредит по отношению к Продавцу, вне зависимости от причин его возникновения.

G.- ПРЕТЕНЗИИ

G.1.- При получении Продукции Покупатель должен внимательно осмотреть ее в соответствии с указаниями п. 7 стандарта UNI EN ISO 10545-2

G.2.- При установке и укладке Продукции необходимо внимательно придерживаться рекомендаций по работам, выполняемым до и во время укладки, приведенных в

документе 1) Руководство по укладке, использованию, чистке и уходу, размещенном на сайте Продавца в интернете, а также рекомендаций, указанных на упаковке изделия и/или приведенных внутри упаковки. Не считаются дефектами Продукции дефекты, возникшие в результате неправильной установки, отсутствия / неправильного ухода (не в соответствии с указаниями, приведенными в 1) Руководстве по укладке, использованию, чистке и уходу), по причине неподходящей сферы применения и/или обычного износа с течением времени.

G.3.- Соблюдая пределы приемлемости, предусмотренные международным стандартом EN 14411 (ISO 13006), стороны признают как явные дефекты те дефекты Продукции, которые были заметными уже при ее получении, и которые делают материал неподходящим для применения или существенно снижают его ценность. В эту категорию входят дефекты в соответствии с определением, приведенным в документе 1) Руководство по укладке, использованию, чистке и уходу, размещенном на сайте Продавца в интернете. В качестве исчерпывающего перечня признаются как явные дефекты следующие: дефекты поверхности, декора, шлифовки/полировки, калибра, плоскостности, ортогональности-прямолинейности, толщины, трещины, сколы, несоответствие тона, смешение тона, а также изделия с дефектами резки и сколами.

G.4.- Если Покупатель обнаруживает явные дефекты, то он должен предъявить претензию Продавцу в письменном виде в течение 8 (восемь) дней с момента получения Продукции, в противном случае он теряет право на претензию, кроме того, Покупатель должен оставить всю партию материала в распоряжении Продавца. В претензии необходимо указать данные инвойса и точное описание дефекта, сопровождая его, если это возможно, фотографиями. Если претензия окажется необоснованной, то Покупатель должен быть готовым возместить Продавцу расходы, понесенные им в связи с осмотром на месте (экспертизы, проезд и т.д.).

G.5.- О скрытых дефектах необходимо сообщать Продавцу заказным письмом с уведомлением о вручении в течение не более 8 (восемь) дней с момента обнаружения дефекта, в противном случае гарантия теряет силу.

G.6.- В любом случае, предоставленная Покупателю гарантия на дефекты теряет силу по истечении 12 (двенадцати) месяцев с момента получения Продукции.

H.- ГАРАНТИЯ НА ДЕФЕКТЫ

H.1. Гарантия Продавца распространяется только на Продукцию первого сорта, и не распространяется на Продукцию второго, третьего сорта, а также на партии со спецпредложениями, по которым были предложены специальные скидки или цены, отмеченные в примечаниях в подтверждении заказа.

H.2. Продавец не гарантирует пригодность Продукции для специальных видов применения, а лишь только ее технические характеристики, размещенные на сайте в интернете, в документе 2) Технические данные. Сфера применения, даже если она указана Продавцом в каталогах и руководствах, должна считаться лишь только ориентировочной. На основании технических характеристик, приведенных в 2) Технических данных, проектировщик обязан оценить пригодность Продукции к конкретным условиям применения, в зависимости от нагрузок и от переменных факторов, которые могут возникнуть в среде применения, изменяя характеристики Продукции, такие как: интенсивность хождения, качество хождения (наличие песка, мусора и т.д.), возможные неблагоприятные климатические условия и любые другие случайные факторы, которые могут оказать воздействие на материал.

H.3.- В случае установления того факта, что Продукция имеет явные дефекты в соответствии с положениями п. 3 раздела G, Продавец заменит дефектную Продукцию другой, обладающей такими же или более высокими характеристиками. Если это невозможно, то он надлежащим образом снизит цену. В качестве альтернативы после возврата дефектной Продукции Покупатель имеет право на возмещение уплаченной цены и транспортных расходов, при этом исключено возмещение любого другого прямого и/или косвенного ущерба.

H.4. Гарантия Продавца считается отмененной в случае, если Продукция, частично или полностью имеющая явные дефекты, была использована и/или трансформирована каким-либо образом, поскольку считается, что этими действиями Покупатель (или его клиент) выразил волю принять Продукцию в том состоянии, в котором она находится.

H.5 В случае установления того факта, что Продукция имеет скрытые дефекты, гарантия Продавца ограничена заменой материала другим, обладающим такими же или более высокими характеристиками. Если это невозможно, то Продавец возместит уплаченную цену и транспортные расходы. В любом случае, гарантия Продавца на любой прямой и/или косвенный ущерб, вызванный каким-либо образом дефектной Продукцией, ограничена суммой, которая не может превышать больше, чем в два раза, востребованную Продавцом отпускную цену, и лишь только в отношении к дефектной части поставки.

H.6.- Если Покупатель перепродает Продукцию лицам, которые защищены Кодексом потребителя (законодательный декрет № 206/2005), то он несет ответственность за предоставляемые условия, если они отличаются от приведенных здесь, кроме того, он обязан удостовериться в том, что права потребителя защищаются с соблюдением мер и сроков, предусмотренных вышеуказанным Кодексом. При наличии соответствующих предпосылок право регресса и/или право на взыскание убытков, которое Покупатель имеет по отношению к Продавцу/производителю, не может превышать исключения и пределы, установленные в п. 1 раздела G и в п. 5 раздела H.

I. УСЛОВИЯ ОБ ОБЯЗАТЕЛЬНОЙ ОПЛАТЕ (SOLVE ET REPETE) И О ДОСРОЧНОМ ОДНОСТОРОННЕМ РАСТОРЖЕНИИ

I.1.- В соответствии со ст. 1462 гражданского кодекса Покупатель не вправе ни по какой причине, в том числе в связи с претензиями по поводу качества или дефектности товара, приостанавливать или задерживать оплату вывезенного материала, сохраняя, тем не менее, право требовать возмещение, если он докажет неправомерное взимание оплаты.

I.2.- В случае изменения имущественного положения Покупателя или даже частичной неоплаты уже поставленной Продукции, Продавец может приостановить исполнение текущих поставок и/или расторгнуть текущие договоры, и Покупатель не имеет права потребовать какого-либо возмещения прямых и/или косвенных убытков.

L.- ПОЛОЖЕНИЕ О СОХРАНЕНИИ ПРАВА СОБСТВЕННОСТИ

L.1.- Поставляемая Продукция будет оставаться в собственности Продавца до тех пор, пока Покупатель полностью не оплатит ее.

L.2.- В течение этого периода Покупатель несет обязательства и ответственность хранителя и не может уступать, предоставлять в пользование, разрешать наложение имущественного ареста или опись Продукции, не заявив, что она находится в собственности Продавца, и не известив его немедленно заказным письмом с уведомлением о вручении.

M.- ФОРС-МАЖОР

M1.- Любая из сторон имеет право приостановить исполнение своих контрактных обязательств, если это исполнение стало невозможным или объективно обременительным по причине непредвиденных событий, находящихся вне ее контроля, таких как, например: забастовка, бойкот, локаут, пожар, война (объявленная или нет), гражданская война, бунт, революция, конфискация, эмбарго, энергетическая блокада, непредвиденный выход из строя оборудования, задержки в поставках компонентов или сырья.

M2.- Сторона, желающая сослаться на настоящее условие, должна немедленно сообщить в письменной форме другой стороне о возникновении и прекращении форс-мажорных обстоятельств.

M3.- Если приостановка в связи с форс-мажорными обстоятельствами продлится более 60 (шестидесяти) дней, то каждая из сторон имеет право расторгнуть настоящий договор, отправив предварительное письменное уведомление об этом другой стороне за 10 (десять) дней.

N.- ОБЯЗАТЕЛЬСТВО О НЕРАЗГЛАШЕНИИ КОНФИДЕНЦИАЛЬНОЙ ИНФОРМАЦИИ

N.1.- Покупатель обязан соблюдать максимальную конфиденциальность о всей информации технического характера (такая как, но не ограничиваясь этим, чертежи, проспекты, документация, формулы и переписка) и коммерческого характера (включая договорные условия, отпускные цены, условия платежа и т.д.), которая попала в его распоряжение в ходе исполнения настоящего договора.

N.2.- Обязательство о неразглашении конфиденциальной информации действует в течение всего срока действия договора, а также в период после его исполнения.

N.3.- В случае невыполнения обязательства о неразглашении конфиденциальной информации невыполняющая сторона обязана возместить другой стороне все убытки, вытекающие из ее нарушения.

O.- ТОРГОВЫЕ МАРКИ И ОТЛИЧИТЕЛЬНЫЕ ЗНАКИ ПРОДАВЦА

O.1. - Категорически запрещается использование торговых марок, орнаментальных промышленных образцов и предметов интеллектуальной собственности вообще, в любом виде или форме выражения (например, только в качестве неполного перечня: изображения, фотографии, чертежи, видеосъемки, рисунки, конструкции и т.д.), являющихся интеллектуальной собственностью Продавца, в любых СМИ (например, только в качестве неполного перечня: печать, видеоканалы, радиовещание, интернет, социальные сети,

платформы для обмена сообщениями или VoIP-платформы). Любое, даже только частичное отступление от этого запрета должно письменно разрешаться в каждом отдельном случае Генеральной дирекцией Продавца.

P.- ЯЗЫК ДОГОВОРА, ПРИМЕНИМЫЙ ЗАКОН, ЮРИСДИКЦИЯ И КОМПЕТЕНЦИЯ

P.1.- Договор и настоящие условия составлены на итальянском языке, который преобладает в случае разночтений с переводом на другие языки.

P.2.- Любой спор, каким-либо образом связанный с поставками, регулируется итальянским законом и подлежит юрисдикции Итальянского государства, а территориальная компетенция принадлежит исключительно суду г. Модены, в округе которого Продавец имеет свой юридический адрес.

Note

Notes - Notes

Anmerkung - Примечания

Caesar si riserva la facoltà di apportare variazioni ai prodotti illustrati in questo catalogo per necessità produttive o al fine di migliorarne la qualità. I campioni sono puramente indicativi. Gli imballaggi e i pesi riportati possono variare per necessità produttive. Consultare gli uffici commerciali al momento dell'ordine.

Caesar reserves the right to modify the products illustrated in this catalogue for reasons of production or to improve quality. Samples are purely indicative. Packaging and weights may vary for production reasons. Contact our sales department when ordering.

Caesar se réserve le droit d'apporter toute modification aux matériaux reproduits dans ce catalogue et ce, pour des raisons de production ou pour améliorer leur qualité. Les échantillons ont une valeur purement indicative. Les emballages et les poids indiqués peuvent changer pour des raisons de production. Renseignez vous auprès des services commerciaux au moment de passer votre commande.

Caesar behält sich das Recht vor, Änderungen an den in diesem Katalog gezeigten Produkten anzubringen, falls dies für die Herstellung oder die Verbesserung der Qualität erforderlich ist. Die gezeigten Muster sind unverbindlich. Die angegebenen Verpackungen und Gewichtsangaben können aus Gründen der Herstellung abweichen. Setzen Sie sich bei der Bestellung mit unserer Verkaufsabteilung in Verbindung.

Le tonalità dei campioni sono da considerarsi puramente indicative - Tones of samples are indicative - Les tonalités des Échantillons sont Purement Indicatives. - Die Farbtöne der Muster sind als rein Indicativ zu Betrachten.- Тона образцов Ориентировочные.

• CÆSAR •

C E R A M I C H E



Headquarter
Ceramiche Caesar S.p.A.
Via Canaletto, 49, 41042 - Spezzano di Fiorano - Modena - Italy
Tel: +39 0536 817111

Caesar Ceramics USA, INC.
500 Wilson Pike Cir, Ste 127, 37027-3261 - Brentwood TN - USA
Tel: +1 (615) 986-1500

London Urban Lab
17-18 Great Sutton Street, EC1V 0DP - London - UK
Tel: +44 (0) 20 7836 4662

Paris Urban Lab
10b, Rue Saint Nicolas, 75012 - Paris - France
Tel: +33 1 44 73 42 02

Milano Urban Lab
Via Molino delle Armi, 14, 20123 - Milano - Italy

Collezioni 2023

◆ CÆSAR ◆
C E R A M I C H E

Ceramiche Caesar S.p.A.

Via Canaletto, 49, 41042 - Spezzano di Fiorano - Modena - Italy
Tel. +39 0536 817111 - Fax +39 0536 817298 - 817300
www.caesar.it - info@caesar.it